

SPECIFICATION

Revision: A

Product Model: QST2D4002-T-A

Designed by	R&D Checked by	Quality Department by	Approved by
Terry			

Approval by Customer

<p>OK</p> <p>NG, Problem survey:</p> <p>Approved By _____</p>

1. If there is no special request from customer, quality Co.,ltd. Will not reserve the tooling of the product under the following conditions:
 - 1.1 There is no response from customer in one year after quality Co.,ltd. Submit the samples;
 - 1.2 There is no order in one year after the latest mass production.
2. All correlated data (include quality record) will be reserved one year more after tooling was discarded.
3. If there is no special request from customer, The product of quality Co., ltd. Will repair only one year.

1. Numbering System

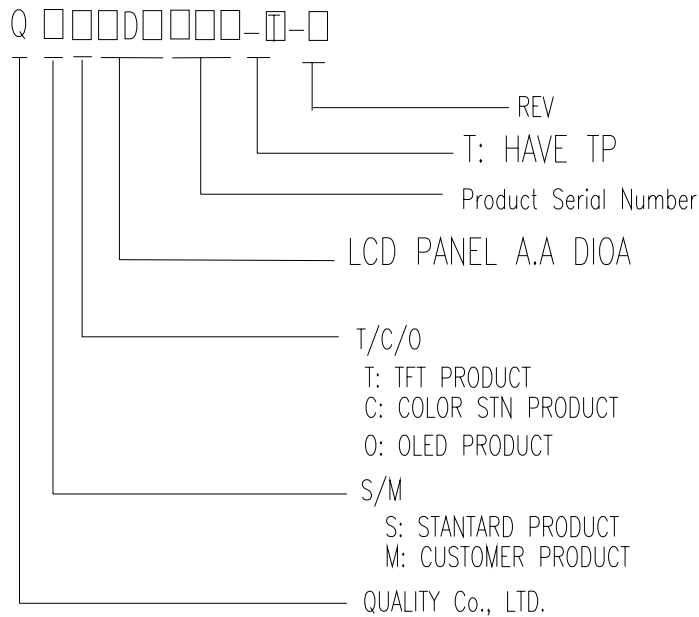

2. GENERAL INFORMATION

ITEM	STANDARD VALUES	UNITS
LCD type	2.4" TFT	--
Dot arrangement	240 (RGB) × 320	dots
Driver IC	SPFD5408A	--
Module size	42.72(W) × 59.28(H) × 3(T)	mm
View area	40.58 (W) × 52.82(H)	mm
Active area	36.72(W) × 48.96(H)	mm
Dot pitch	0.153 (W) × 0.153 (H)	mm
Back Light	Four White LED In Parallel	--
Weight	TBD	g

3. EXTERNAL DIMENSIONS

For Reference Only

Customer's Approval
Customer
Date

No.	SYMBOL	PIN FUNCTION:
1	NC	
2	NC	
3	NC	
4	IM3	
5	NC	
6	RESET	
7	VSYNC	
8	HSYNC	
9	DOTCLK	
10	ENABLE	
11	DB17	
12	DB16	
13	DB15	
14	DB14	
15	DB13	
16	DB12	
17	DB11	
18	DB10	
19	DB9	
20	DB8	
21	DB7	
22	DB6	
23	DB5	
24	DB4	
25	DB3	
26	DB2	
27	DB1	
28	DB0	
29	RD	
30	WR	
31	DC	
32	CS	
33	VSS	
34	VCC	
35	LED-	
36	LED+	

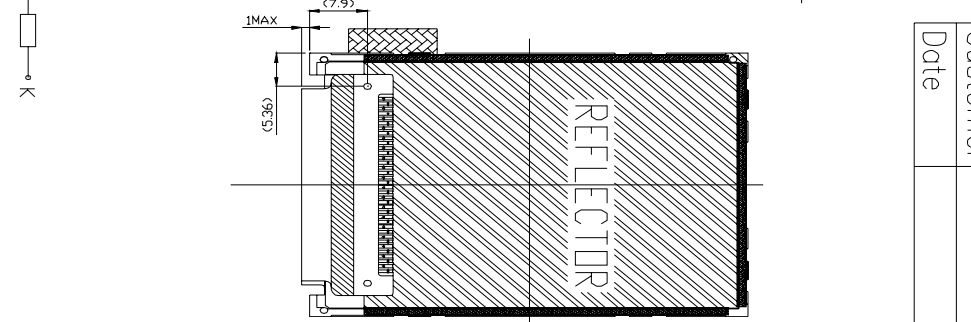
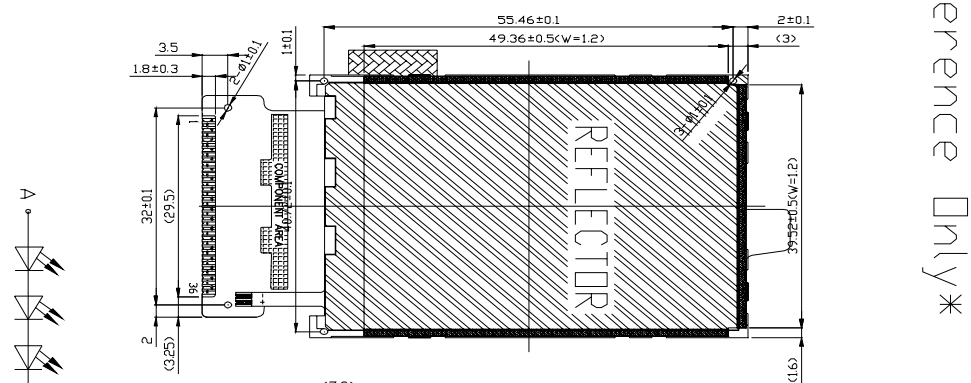
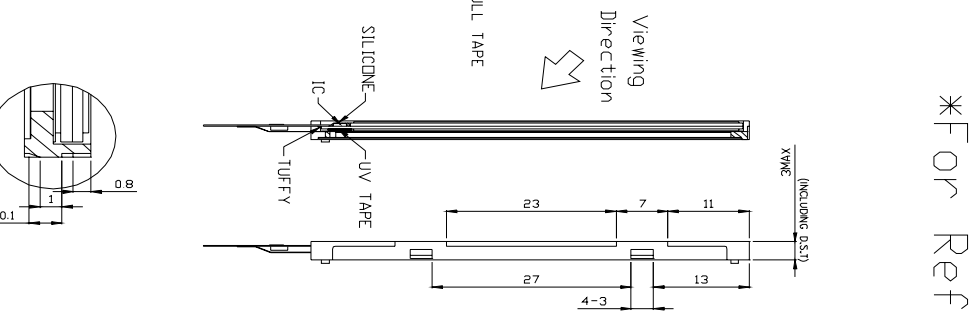
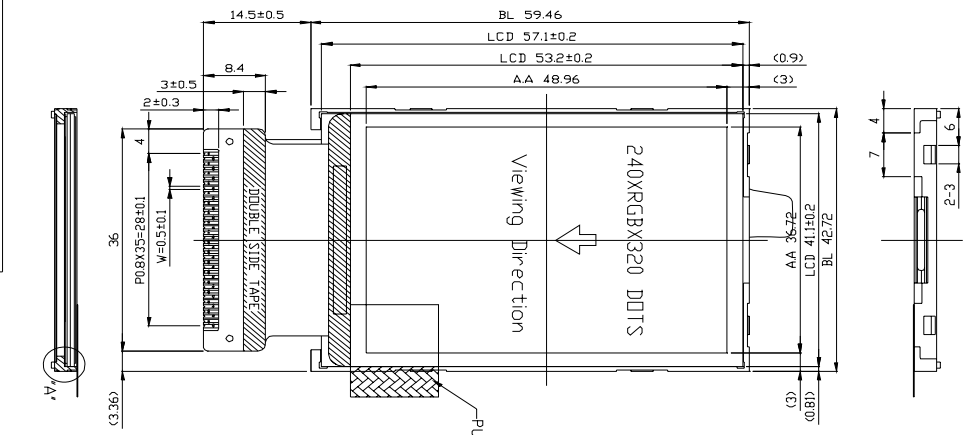

产品符合ROHS要求

ITEM	ELECTRICAL & PHYSICAL DATA
LCD Type	2.4" TFT
Viewing Direction	12 O'CLOCK
Drive Method	DUTY
VDD	3.0V
Display Mode	Transmissive
Operating Temp.	-20°C ~ 70°C
Storage Temp.	-30°C ~ 80°C
Connector	COG(SPF5409)

DETAIL "A" (S-31)

BACKLIGHT CIRCUIT

SCALE	FREE TOLERANCE	UNIT	mm
±0.2 <td>1.5.07 <td>Rebel <td></td> </td></td>	1.5.07 <td>Rebel <td></td> </td>	Rebel <td></td>	
MATERIAL	DRAWN BY	CHECKED BY	CONCURRED BY
FINISH	APPROVED BY		
PROJECT NO.: IHT24QCN0		MODEL: IHT24QCN0V1	
DWG: IHT24QCN0-V1.0		DCN	A4
		P	1 OF 1
		VERSION	1.0

4. INTERFACE DESCRIPTION

Pin No.	Symbol	Function	Note
1-3	NC	Not Connect	
4	IM3	16/18 bit select pin	
5	NC	Not Connect	
6	RESET	Reset pin.	
7	VSYNC	Vertical synchronization signal input pin	
8	HSYNC	Horizontal synchronization signal input pin	
9	DOTCLK	Dot clock signal input used in the RGB interface circuit	
10	DEN	Enable signal pin used in RGB interface circuit	
11-28	DB17-DB0	18-bit data bus	
29	RD	Read enable clock input pin	
30	WR	Write enable clock input pin	
31	DC	Command/Display data select pin	
32	CS	Chip select pin	
33	VSS	Ground	
34	VCC	Power supply	
35	LED-	The LED power supply (-)	
36	LED+	The LED power supply (+)	

5. ABSOLUTE MAXIMUM RATINGS

Item	Symbol	Unit	Value	Note
Power Supply Voltage1	VCC,IOVCC	V	-0.3 ~+4.6	
Power Supply Voltage 2	VCI – AGND	V	-0.3 ~+4.6	
Power Supply Voltage 3	DDVDH – AGND	V	-0.3 ~+6.5	
Power Supply Voltage4	AGND – VCL	V	-0.3 ~+4.6	
Power Supply Voltage 5	DDVDH – VCL	V	-0.3 ~+9.0	
Power Supply Voltage7	AGND – VGL	V	-0.3 ~+14.0	
Power Supply Voltage 8	VGH– VGL	V	-0.3 ~+30.0	
Input Voltage	Vt	V	-0.3 ~IOVCC + 0.3	
Operating Temperature	Topr	°C	-40 ~+85	
Storage Temperature	Tstg	°C	-55 ~+110	

6. DC Characteristics.

VCC=2.50V~3.30V, IOVCC=1.65V~ 3.30V, Ta=-40°C~+85°C

Item	Sym bol	Unit	Test Condition	Mi n.	Typ.	Max.	Note
Input High level voltage	V _{IH}	V	IOVCC=1.65V~3.30V	0.8xIOVCC	-	IOVCC	
Input Low level voltage	V _{IL}	V	IOVCC=1.65V~3.30V	-0.3	-	0.2xIOVCC	
Output "High" level voltage 1 (DB0-17)	V _{OH}	V	IOVCC=1.65V~3.30V, IOH=0.1mA	0.8xIOVCC	-	-	
Output "Low" level voltage 1 (DB0-17)	V _{OL}	V	IOVCC=1.65V~3.30V, IOL=0.1mA	-	-	0.2xIOVCC	
I/O leak current	I _{LI}	μA	V _{in} =0~IOVCC	-1	-	1	
Current Consumption (IOVCC-IOGND)+(VCC-GND) Normal operation mode (262k-colors, display operation)	I _{OP1}	μA	fosc=376kHz (320line drive), IOVCC=VCC=3.00V, fFLM=70Hz, Ta=25°C, RAM data: 18'h000000, See below for other data -	-	175	-	
Current Consumption (IOVCC-IOGND)+(VCC-GND) 8-color mode, 64-line, partial display operation	I _{OP2}	μA	fosc=376kHz (64-line, partial display), IOVCC=VCC=3.00V, fFLM=40Hz, Ta=25°C RAM data: 18'h000000, See below for other data	-	140	-	

8. BACKLIGHT CHARACETRISTIC

Item	Symbol	Min.	Typical	Max.	Unit
LED module Forward voltage	V _{LED}	9.0	----	10.2	V
LED module current	I _{LED}	----	20	----	mA
L/G Surface brightness Luminance ★1	L _s	2900	-----	4100	Cd/m ²
LCM Surface brightness uniform ★2	L _D	80	-----	----	%

★1 Test condition is :

- (a) Center point on active area
- (b) Best Contrast

★2 Uniform measure condition :

- (1)Measure 9 point. Measure location is show below
- (2)Uniform = (Min. brightness / Max. brightness) ×100%
- (3)Best Contrast.

★1 Test condition is :

- (a) Center point on active area
- (b) Best Contrast

★2 Uniform measure condition :

- (1) Measure 9 point. Measure location is show below
- (2) Uniform = (Min. brightness / Max. brightness) × 100%
- (3) Best Contrast.

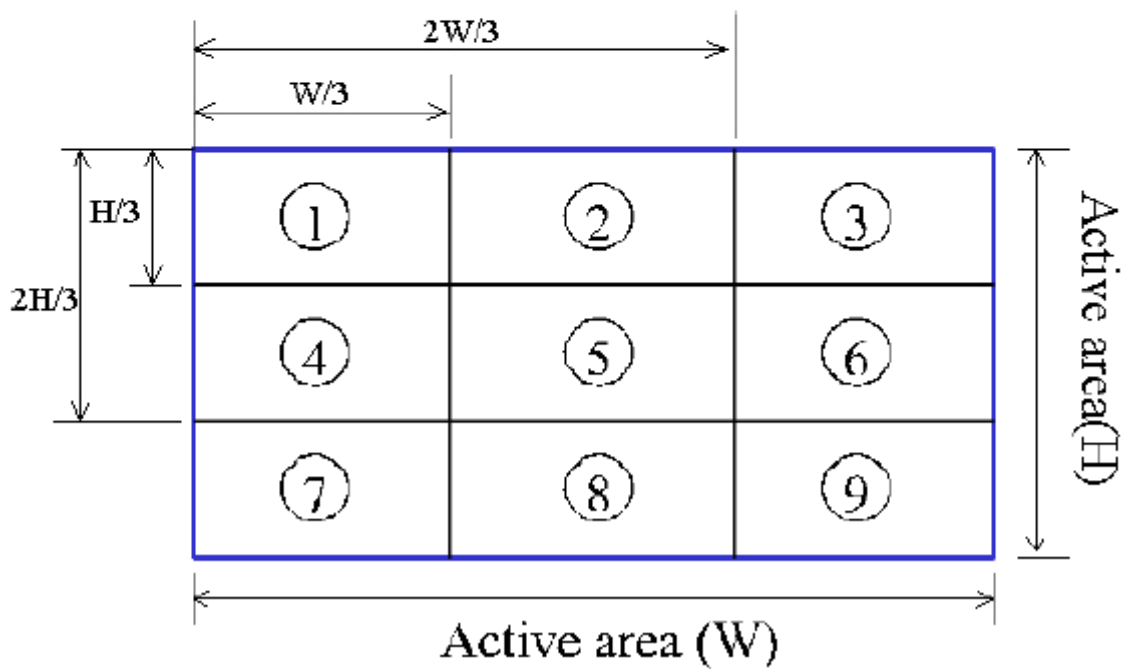

8. Application circuit

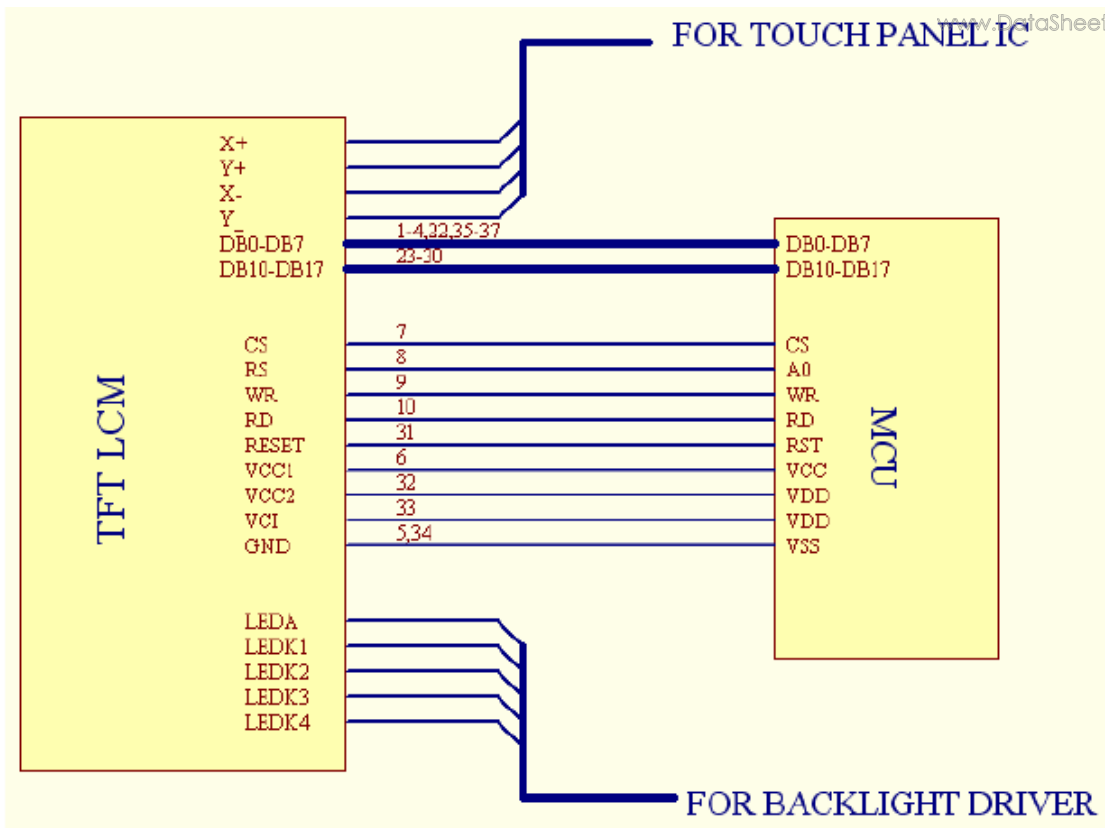

9. Reliability Test Conditions And Methods

NO	Item	Condition	Method
1	High / Low Temperature Storage	60°C/-20°C 500hrs	Check and record every 96Hrs
2	High / Low Temperature Life	50°C/-10°C 500hrs (operating mode)	Check and record every 96Hrs
3	High Temperature、High Humidity Operating	40°C 90% RH, 120Hrs	Check and record every 48hrs
4	Thermal Shock	-30°C(30Min) → 25°C(5Min) → 80°C(30Min) (conversion time, : 5 sec) 20 cycles	Each 10 cycles end , check
5	Vibration	10Hz~55Hz~10Hz Amplitude: 1.5mm 2hrs for each direction(X,Y,Z)	Each direction end, Check the Appearance and Electrical Characteristics
6	Static Electricity	Gap mood: ±1KV~±8KV (10 times air discharge with positive/negative voltage voltage gap : 1kv) Touch mood: ±1KV~±2KV	Each discharge end, Check the Electrical Characteristics
7	Slump	Free faller movement for each side、cording、 angle (75cm High、 6 sides、 2 angle、 2 cording)	End

10. Inspection standard

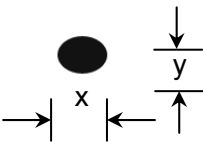
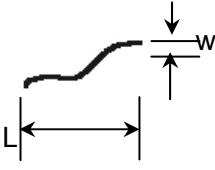
No	Item	Criterion														
01	Outline Dimension	In accord with drawing														
02	Position-finding Dimension Assemble Dimension	In accord with drawing														
03	LCD black spots, white spots (Round type)	<p>Round type: non display</p>  <p>Unit : mm</p> <table border="1"> <thead> <tr> <th>Dimension</th> <th>Qualified Quantity</th> </tr> </thead> <tbody> <tr> <td>$D \leq 0.1$</td> <td>Ignore</td> </tr> <tr> <td>$0.1 < D \leq 0.15$</td> <td>3</td> </tr> <tr> <td>$0.15 < D \leq 0.25$</td> <td>2</td> </tr> <tr> <td>$D > 0.25$</td> <td>0</td> </tr> </tbody> </table>	Dimension	Qualified Quantity	$D \leq 0.1$	Ignore	$0.1 < D \leq 0.15$	3	$0.15 < D \leq 0.25$	2	$D > 0.25$	0				
Dimension	Qualified Quantity															
$D \leq 0.1$	Ignore															
$0.1 < D \leq 0.15$	3															
$0.15 < D \leq 0.25$	2															
$D > 0.25$	0															
04	LCD black spots, white spots (Line Style)	<p>Unit : mm</p>  <table border="1"> <thead> <tr> <th>Length</th> <th>Width</th> <th>Qualified Quantity</th> </tr> </thead> <tbody> <tr> <td>-</td> <td>≤ 0.02</td> <td>Ignore</td> </tr> <tr> <td>≤ 3</td> <td rowspan="2">$0.02 < W \leq 0.03$</td> <td>2</td> </tr> <tr> <td>≤ 2</td> <td>1</td> </tr> <tr> <td>-</td> <td>$D > 0.05$</td> <td>According to circle</td> </tr> </tbody> </table>	Length	Width	Qualified Quantity	-	≤ 0.02	Ignore	≤ 3	$0.02 < W \leq 0.03$	2	≤ 2	1	-	$D > 0.05$	According to circle
Length	Width	Qualified Quantity														
-	≤ 0.02	Ignore														
≤ 3	$0.02 < W \leq 0.03$	2														
≤ 2		1														
-	$D > 0.05$	According to circle														
05	LCD Scratch、Threadlike Fiber	<p>Same to NO.3 circle sightline and surface of LCD is vertical</p> <p>(2)Same to NO.3 line style</p>														

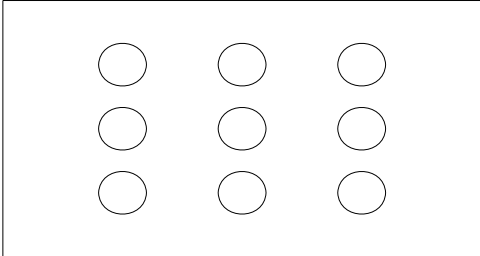
06	POL	It is not admissible that POL is beyond the edge of glass, else, unqualified. It is essential that POL is over the 50 percent of width of frame , else ,unqualified. According to the drawing in case of special definition.	
07	Brightness	In accord with product specification	<p>Drive condition is according to specification Measure location is in Follow Picture 3、 Adjust brightness instrument to zero , burrow against the surface of LCD , press “measure” , record when the display is steady. (YOKOGAWA-3298)</p>  <p style="text-align: center;">Measure location</p>
08	CR (Max)	According to specification	According to product specification Measure instrument (DMS-501)
09	Response time	According to specification	According to product specification Measure instrument (DMS-501)
10	Viewing angle	According to specification	According to product specification Measure instrument (DMS-501)
11	Vibration、 Ring	Compare with the sample customer supply	Compare with the sample customer supply when assemble

11. Handling Precautions

11.1 Mounting method

The LCD panel of SkyworthLCD LCD module consists of two thin glass plates with polarizes which easily be damaged. And since the module in so constructed as to be fixed by utilizing fitting holes in the printed circuit board.

Extreme care should be needed when handling the LCD modules.

11.2 Caution of LCD handling and cleaning

When cleaning the display surface, Use soft cloth with solvent [recommended below] and wipe lightly

- Isopropyl alcohol

- Ethyl alcohol

Do not wipe the display surface with dry or hard materials that will damage the polarizer surface.

Do not use the following solvent:

- Water
- Aromatics

Do not wipe ITO pad area with the dry or hard materials that will damage the ITO patterns

Do not use the following solvent on the pad or prevent it from being contaminated:

- Soldering flux
- Chlorine (Cl) , Sulfur (S)

If goods were sent without being silicon coated on the pad, ITO patterns could be damaged due to the corrosion as time goes on.

If ITO corrosion happens by miss-handling or using some materials such as Chlorine (Cl), Sulfur (S) from customer, Responsibility is on customer.

11.3 Caution against static charge

The LCD module uses C-MOS LSI drivers, so we recommend that you:

Connect any unused input terminal to Vdd or Vss, do not input any signals before power is turned on, and ground your body, work/assembly areas, assembly equipment to protect against static electricity.

11.4 packing

- Modules employ LCD elements and must be treated as such.
- Avoid intense shock and falls from a height.
- To prevent modules from degradation, do not operate or store them exposed directly to sunshine or high temperature/humidity

11.5 Caution for operation

- It is an indispensable condition to drive LCD's within the specified voltage limit since the higher voltage than the limit causes the shorter LCD life.
- An electrochemical reaction due to direct current causes LCD's undesirable deterioration, so that the use of direct current drive should be avoided.
- Response time will be extremely delayed at lower temperature than the operating temperature range and on the other hand at higher temperature LCD's show dark color in them. However those phenomena do not mean malfunction or out of order with LCD's, which will come back in the specified operation temperature.
- If the display area is pushed hard during operation, some font will be abnormally displayed but it resumes normal condition after turning off once.
- A slight dew depositing on terminals is a cause for electro-chemical reaction resulting in terminal open circuit.
Usage under the maximum operating temperature, 50%Rh or less is required.

11.6 storage

In the case of storing for a long period of time for instance, for years for the purpose or replacement use, the following ways are recommended.

- Storage in a polyethylene bag with the opening sealed so as not to enter fresh air outside in it. And with no desiccant.
- Placing in a dark place where neither exposure to direct sunlight nor light's keeping the storage temperature range.
- Storing with no touch on polarizer surface by anything else.
[It is recommended to store them as they have been contained in the inner container at the time of delivery from us]

11.7 Safety

- It is recommendable to crash damaged or unnecessary LCD's into pieces and wash off liquid

crystal by either of solvents such as acetone and ethanol, which should be burned up later.

- When any liquid leaked out of a damaged glass cell comes in contact with your hands, please wash it off well with soap and water

12. Precaution for use

12.1

A limit sample should be provided by the both parties on an occasion when the both parties agreed its necessity. Judgment by a limit sample shall take effect after the limit sample has been established and confirmed by the both parties.

12.2

On the following occasions, the handing of problem should be decided through discussion and agreement between responsible of the both parties.

- When a question is arisen in this specification
- When a new problem is arisen which is not specified in this specifications
- When an inspection specifications change or operating condition change in customer is reported to SkyworthLCD , and some problem is arisen in this specification due to the change
- When a new problem is arisen at the customer's operating set for sample evaluation in the customer site.

12 Packing method

To Be Determined