

Single-channel high side driver

Features

Type	R _{DS(on)}	I _{OUT}	V _{CC}
VN920-E	16 mΩ	30 A	36 V
VN920-12-E			

- CMOS compatible input
- Proportional load current sense
- Shorted load protection
- Under voltage and overvoltage shutdown
- Overvoltage clamp
- Thermal shutdown
- Current limitation
- Protection against loss of ground and loss of V_{CC}
- Very low standby power dissipation
- Reverse battery protected (see [Application schematic on page 16](#))
- In compliance with the 2002/95/ec european directive

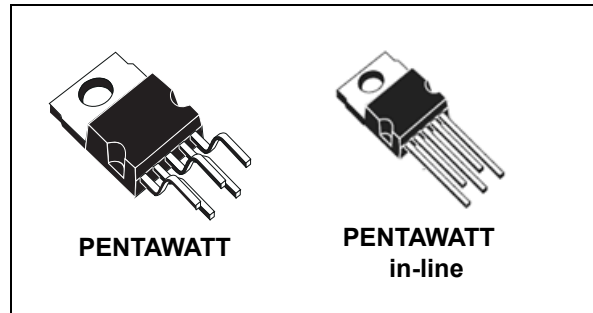

Description

The VN920-E is a monolithic device designed in STMicroelectronics VIPower™ M0-3 technology, intended for driving any kind of load with one side connected to ground. Active V_{CC} pin voltage clamp protects the device against low energy spikes (see ISO7637 transient compatibility able).

Active current limitation combined with thermal shutdown and automatic restart protect the device against overload. The device integrates an analog current sense output which delivers a current proportional to the load current. Device automatically turns off in case of ground pin disconnection.

Table 1. Device summary

Package	Order codes	
	Tube	Tape and reel
PENTAWATT	VN920-E	-
PENTAWATT in-line	VN920-12-E	-

Contents

- 1 Block diagram and pin description 5**

- 2 Electrical specifications 6**
 - 2.1 Absolute maximum ratings 6
 - 2.2 Thermal data 7
 - 2.3 Electrical characteristics 7
 - 2.4 Electrical characteristics curves 14

- 3 Application information 16**
 - 3.1 GND protection network against reverse battery 16
 - 3.1.1 Solution 1: resistor in the ground line (RGND only) 16
 - 3.1.2 Solution 2: diode (DGND) in the ground line 17
 - 3.2 Load dump protection 17
 - 3.3 MCU I/Os protection 17

- 4 Package and packing information 18**
 - 4.1 ECOPACK® packages 18
 - 4.1.1 PENTAWATT (vertical) mechanical data 18
 - 4.1.2 PENTAWATT (in-line) mechanical data 20
 - 4.2 PENTAWATT packing information 21

- 5 Revision history 22**

List of tables

Table 1.	Device summary	1
Table 2.	Suggested connections for unused and not connected pins	5
Table 3.	Absolute maximum ratings	6
Table 4.	Thermal data	7
Table 5.	Power	7
Table 6.	Switching ($V_{CC}=13V$)	8
Table 7.	Logic inputs	8
Table 8.	V_{CC} output diode	8
Table 9.	Protections	8
Table 10.	Current sense (9V £ VCC £ 16V)	9
Table 11.	Truth table	11
Table 12.	Electrical transient requirements (part 1/3)	11
Table 13.	Electrical transient requirements (part 2/3)	11
Table 14.	Electrical transient requirements (part 3/3)	12
Table 15.	PENTAWATT (vertical) mechanical data	18
Table 16.	PENTAWATT (in-line) mechanical data	20
Table 17.	Document revision history	22

List of figures

Figure 1.	Block diagram	5
Figure 2.	Configuration diagram (top view)	5
Figure 3.	Current and voltage conventions	6
Figure 4.	I_{OUT}/I_{SENSE} versus I_{OUT}	10
Figure 5.	Switching characteristics	10
Figure 6.	Waveforms	13
Figure 7.	Off-state output current	14
Figure 8.	High level input current	14
Figure 9.	Input clamp voltage	14
Figure 10.	On-state resistance vs V_{CC}	14
Figure 11.	On-state resistance vs T_{CASE}	14
Figure 12.	Input high level voltage	14
Figure 13.	Input low level voltage	15
Figure 14.	Input hysteresis voltage	15
Figure 15.	Turn-on voltage slope	15
Figure 16.	Turn-off voltage slope	15
Figure 17.	Overshoot shutdown	15
Figure 18.	ILIM vs Tcase	15
Figure 19.	Application schematic	16
Figure 20.	PENTAWATT (vertical) package dimensions	18
Figure 21.	PENTAWATT (in-line) package dimensions	20
Figure 22.	PENTAWATT tube shipment (no suffix)	21

1 Block diagram and pin description

Figure 1. Block diagram

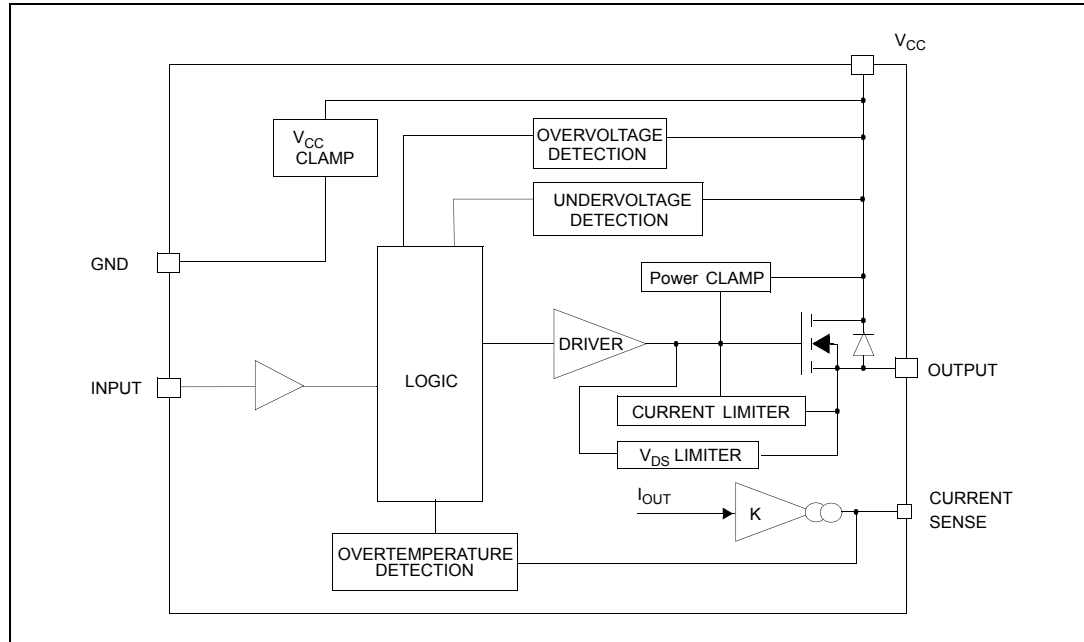

Figure 2. Configuration diagram (top view)

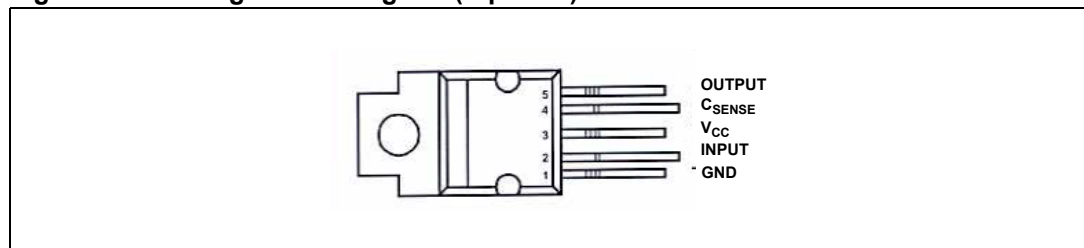
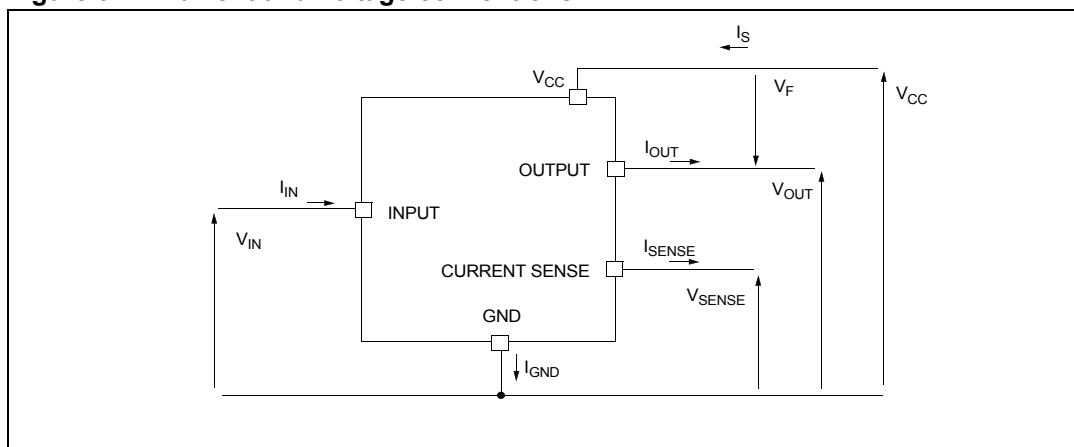

Table 2. Suggested connections for unused and not connected pins

Connection / pin	Current Sense	N.C.	Output	Input
Floating		X	X	X
To ground	Through 1KΩ resistor	X		Through 10KΩ resistor

2 Electrical specifications

Figure 3. Current and voltage conventions



2.1 Absolute maximum ratings

Stressing the device above the rating listed in the “Absolute maximum ratings” table may cause permanent damage to the device. These are stress ratings only and operation of the device at these or any other conditions above those indicated in the operating sections of this specification is not implied. Exposure to Absolute maximum rating conditions for extended periods may affect device reliability. Refer also to the STMicroelectronics sure program and other relevant quality document.

Table 3. Absolute maximum ratings

Symbol	Parameter	Value	Unit
V_{CC}	DC supply voltage	41	V
$-V_{CC}$	Reverse DC supply voltage	- 0.3	V
$-I_{gnd}$	DC reverse ground pin current	- 200	mA
I_{OUT}	DC output current	Internally limited	A
$-I_{OUT}$	Reverse DC output current	- 21	A
I_{IN}	DC input current	+/- 10	mA
V_{CSENSE}	Current sense maximum voltage	- 3 + 15	V V
V_{ESD}	Electrostatic discharge (human body model: $R = 1.5K\Omega$; $C = 100pF$)		
	- Input	4000	V
	- Current sense	2000	V
	- Output	5000	V
	$-V_{CC}$	5000	V

Table 3. Absolute maximum ratings (continued)

Symbol	Parameter	Value	Unit
E_{MAX}	Maximum switching energy ($L = 0.25\text{mH}$; $R_L = 0\Omega$; $V_{bat} = 13.5\text{V}$; $T_{jstart} = 150^\circ\text{C}$; $I_L = 45\text{A}$)		mJ
P_{tot}	Power dissipation $T_C \leq 25^\circ\text{C}$	96.1	W
T_j	Junction operating temperature	Internally limited	$^\circ\text{C}$
T_c	Case operating temperature	- 40 to 150	$^\circ\text{C}$
T_{stg}	Storage temperature	- 55 to 150	$^\circ\text{C}$

2.2 Thermal data

Table 4. Thermal data

Symbol	Parameter	Max. value	Unit
$R_{thj-case}$	Thermal resistance junction-case (max)	1.3	$^\circ\text{C/W}$
$R_{thj-lead}$	Thermal resistance junction-lead (max)	-	$^\circ\text{C/W}$
$R_{thj-amb}$	Thermal resistance junction-ambient (max)	61.3	$^\circ\text{C/W}$

2.3 Electrical characteristics

Values specified in this section are for $8\text{V} < V_{CC} < 36\text{V}$; $-40^\circ\text{C} < T_j < 150^\circ\text{C}$, unless otherwise stated.

Table 5. Power

Symbol	Parameter	Test conditions	Min.	Typ.	Max.	Unit
V_{CC}	Operating supply voltage		5.5	13	36	V
V_{USD}	Undervoltage shutdown		3	4	5.5	V
V_{OV}	Overvoltage shutdown		36			V
R_{ON}	On-state resistance	$I_{OUT} = 10\text{A}$; $T_j = 25^\circ\text{C}$; $I_{OUT} = 10\text{A}$; $I_{OUT} = 3\text{A}$; $V_{CC} = 6\text{V}$			16 32 55	$\text{m}\Omega$ $\text{m}\Omega$ $\text{m}\Omega$
V_{CLAMP}	Clamp voltage	$I_{CC} = 20\text{mA}^{(1)}$	41	48	55	V
I_S	Supply current	Off-state; $V_{CC} = 13\text{V}$; $V_{IN} = V_{OUT} = 0\text{V}$ Off-state; $V_{CC} = 13\text{V}$; $V_{IN} = V_{OUT} = 0\text{V}$; $T_j = 25^\circ\text{C}$ On-state; $V_{CC} = 13\text{V}$; $V_{IN} = 5\text{V}$; $I_{OUT} = 0\text{A}$; $R_{SENSE} = 3.9\text{ k}\Omega$		10 10	25 20	μA μA 5 mA
$I_{L(off1)}$	Off-state output current	$V_{IN} = V_{OUT} = V_{SENSE} = 0\text{V}$	0		50	μA

Table 5. Power (continued)

Symbol	Parameter	Test conditions	Min.	Typ.	Max.	Unit
$I_{L(off2)}$	Off-state output current	$V_{IN} = V_{OUT} = V_{SENSE} = 3.5V$	-75			μA
$I_{L(off3)}$	Off-state output current	$V_{IN} = V_{OUT} = V_{SENSE} = 0V$; $V_{CC} = 13V$; $T_j = 125^\circ C$			5	μA
$I_{L(off4)}$	Off-state output current	$V_{IN} = V_{OUT} = V_{SENSE} = 0V$; $V_{CC} = 13V$; $T_j = 25^\circ C$			3	μA

1. V_{clamp} and V_{OV} are correlated. Typical difference is 5V.

Table 6. Switching ($V_{CC}=13V$)

Symbol	Parameter	Test conditions	Min.	Typ.	Max.	Unit
$t_{d(on)}$	Turn-on delay time	$R_L = 1.3\Omega$ (see Figure 5)	-	50	-	μs
$t_{d(off)}$	Turn-off delay time	$R_L = 1.3\Omega$ (see Figure 5)	-	50	-	μs
$dV_{OUT}/dt_{(on)}$	Turn-on voltage slope	$R_L = 1.3\Omega$ (see Figure 5)	-	See Figure 15	-	$V/\mu s$
$dV_{OUT}/dt_{(off)}$	Turn-off voltage slope	$R_L = 1.3\Omega$ (see Figure 5)	-	See Figure 16	-	$V/\mu s$

Table 7. Logic inputs

Symbol	Parameter	Test conditions	Min.	Typ.	Max.	Unit
V_{IL}	Input low level voltage				1.25	V
I_{IL}	Low level input current	$V_{IN} = 1.25V$	1			μA
V_{IH}	Input high-level voltage		3.25			V
I_{IH}	High-level input current	$V_{IN} = 3.25V$			10	μA
$V_{I(hyst)}$	Input hysteresis voltage		0.5			V
V_{ICL}	Input clamp voltage	$I_{IN} = 1mA$ $I_{IN} = -1mA$	6	6.8 - 0.7	8	V V

Table 8. V_{CC} output diode

Symbol	Parameter	Test conditions	Min.	Typ.	Max.	Unit
V_F	Forward on voltage	$-I_{OUT} = 2A$; $T_j = 150^\circ C$	-	-	0.6	V

Table 9. Protections⁽¹⁾

Symbol	Parameter	Test conditions	Min.	Typ.	Max.	Unit
T_{TSD}	Shutdown temperature		150	175	200	$^\circ C$
T_R	Reset temperature		135			$^\circ C$
T_{hyst}	Thermal hysteresis		7	15		$^\circ C$
I_{lim}	DC short circuit current	$V_{CC} = 13V$ $5V < V_{CC} < 36V$	30	45	75 75	A A

Table 9. Protections⁽¹⁾ (continued)

Symbol	Parameter	Test conditions	Min.	Typ.	Max.	Unit
V_{demag}	Turn-off output clamp voltage	$I_{\text{OUT}} = 2\text{A}; V_{\text{IN}} = 0\text{V};$ $L = 6\text{mH}$	$V_{\text{CC}} - 41$	$V_{\text{CC}} - 48$	$V_{\text{CC}} - 55$	V
V_{ON}	Output voltage drop limitation	$I_{\text{OUT}} = 1\text{A};$ $T_{\text{j}} = -40^{\circ}\text{C} \dots 150^{\circ}\text{C}$		50		mV

1. To ensure long term reliability under heavy over-load or short circuit conditions, protection and related diagnostic signals must be used together with a proper software strategy. If the device operates under abnormal conditions this software must limit the duration and number of activation cycles.

Table 10. Current sense ($9\text{V} \leq V_{\text{CC}} \leq 16\text{V}$)⁽¹⁾

Symbol	Parameter	Test conditions	Min.	Typ.	Max.	Unit
K_1	$I_{\text{OUT}}/I_{\text{SENSE}}$	$I_{\text{OUT}} = 1\text{A}; V_{\text{SENSE}} = 0.5\text{V};$ $T_{\text{j}} = -40^{\circ}\text{C} \dots 150^{\circ}\text{C}$	3300	4400	6000	
dK_1/K_1	Current sense ratio drift	$I_{\text{OUT}} = 1\text{A}; V_{\text{SENSE}} = 0.5\text{V};$ $T_{\text{j}} = -40^{\circ}\text{C} \dots 150^{\circ}\text{C}$	-10		+10	%
K_2	$I_{\text{OUT}}/I_{\text{SENSE}}$	$I_{\text{OUT}} = 10\text{A}; V_{\text{SENSE}} = 4\text{V};$ $T_{\text{j}} = -40^{\circ}\text{C}$ $T_{\text{j}} = 25^{\circ}\text{C} \dots 150^{\circ}\text{C}$	4200 4400	4900 4900	6000 5750	
dK_2/K_2	Current sense ratio drift	$I_{\text{OUT}} = 10\text{A}; V_{\text{SENSE}} = 4\text{V};$ $T_{\text{j}} = -40^{\circ}\text{C} \dots 150^{\circ}\text{C}$	-8		+8	%
K_3	$I_{\text{OUT}}/I_{\text{SENSE}}$	$I_{\text{OUT}} = 30\text{A}; V_{\text{SENSE}} = 4\text{V};$ $T_{\text{j}} = -40^{\circ}\text{C}$ $T_{\text{j}} = 25^{\circ}\text{C} \dots 150^{\circ}\text{C}$	4200 4400	4900 4900	5500 5250	
dK_3/K_3	Current sense ratio drift	$I_{\text{OUT}} = 30\text{A}; V_{\text{SENSE}} = 4\text{V};$ $T_{\text{j}} = -40^{\circ}\text{C} \dots 150^{\circ}\text{C}$	-6		+6	%
I_{SENSE0}	Analog sense leakage current	$V_{\text{CC}} = 6 \dots 16\text{V}; I_{\text{OUT}} = 0\text{A};$ $V_{\text{SENSE}} = 0\text{V};$ $T_{\text{j}} = -40^{\circ}\text{C} \dots 150^{\circ}\text{C}$	0		10	μA
V_{SENSE}	Max analog sense output voltage	$V_{\text{CC}} = 5.5\text{V}; I_{\text{OUT}} = 5\text{A}; R_{\text{SENSE}} = 10\text{k}\Omega$ $V_{\text{CC}} > 8\text{V}, I_{\text{OUT}} = 10\text{A}; R_{\text{SENSE}} = 10\text{k}\Omega$	2 4			V V
V_{SENSEH}	Sense voltage in over temperature condition	$V_{\text{CC}} = 13\text{V}; R_{\text{SENSE}} = 3.9\text{k}\Omega$		5.5		V
R_{VSENSEH}	Analog sense output impedance in over temperature condition	$V_{\text{CC}} = 13\text{V}; T_{\text{j}} > T_{\text{TSD}};$ output open		400		Ω
t_{DSENSE}	Current sense delay response	To 90% I_{SENSE} ⁽²⁾			500	μs

1. See [Figure 4](#).

2. Current sense signal delay after positive input slope.

Figure 4. I_{OUT}/I_{SENSE} versus I_{OUT}

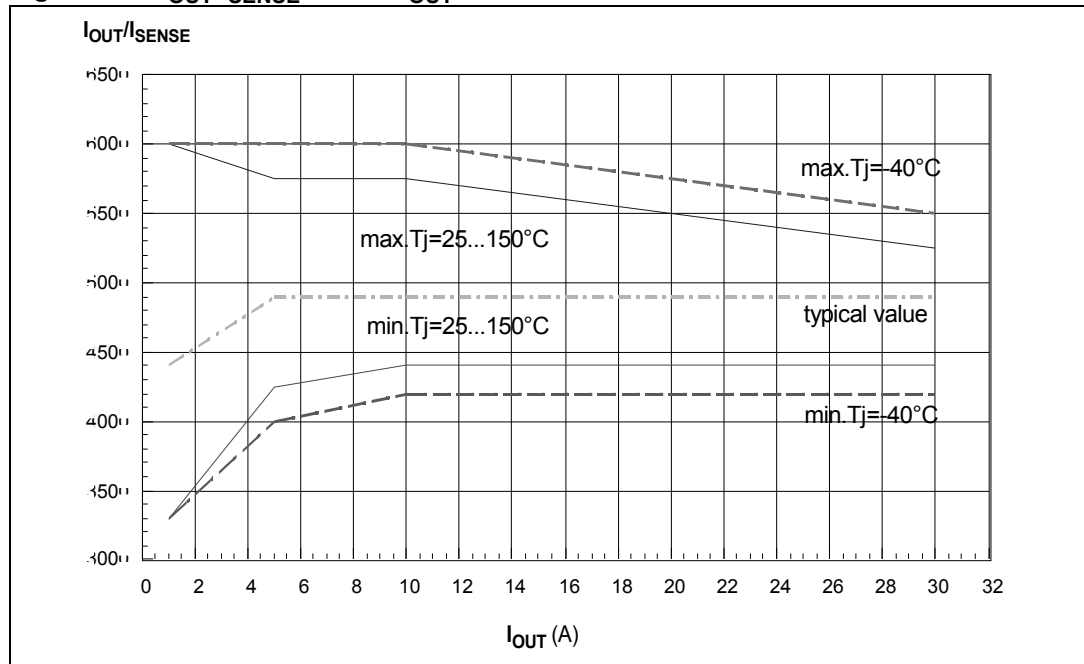

Figure 5. Switching characteristics

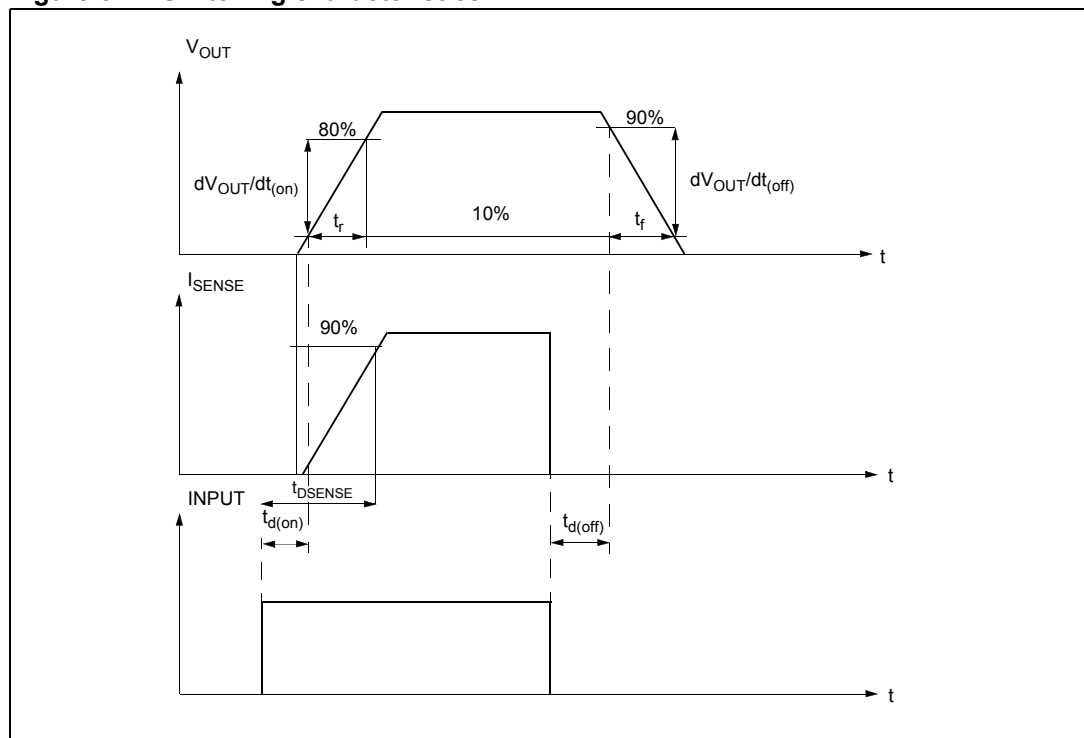

Table 11. Truth table

Conditions	Input	Output	Sense
Normal operation	L	L	0
	H	H	Nominal
Over temperature	L	L	0
	H	L	V_{SENSEH}
Undervoltage	L	L	0
	H	L	0
Overvoltage	L	L	0
	H	L	0
Short circuit to GND	L	L	0
	H	L	$(T_j < T_{TSD}) 0$
	H	L	$(T_j > T_{TSD}) V_{SENSEH}$
Short circuit to V_{CC}	L	H	0
	H	H	< Nominal
Negative output voltage clamp	L	L	0

Table 12. Electrical transient requirements (part 1/3)

ISO T/R 7637/1 Test pulse	Test level				
	I	II	III	IV	Delays and impedance
1	- 25V	- 50V	- 75V	- 100V	2ms, 10 Ω
2	+ 25V	+ 50V	+ 75V	+ 100V	0.2ms, 10 Ω
3a	- 25V	- 50V	- 100V	- 150V	0.1 μ s, 50 Ω
3b	+ 25V	+ 50V	+ 75V	+ 100V	0.1 μ s, 50 Ω
4	- 4V	- 5V	- 6V	- 7V	100ms, 0.01 Ω
5	+ 26.5V	+ 46.5V	+ 66.5V	+ 86.5V	400ms, 2 Ω

Table 13. Electrical transient requirements (part 2/3)

ISO 7637-2: 2004(E) Test pulse	Test level results			
	I	II	III	IV
1	C	C	C	C
2	C	C	C	C
3a	C	C	C	C
3b	C	C	C	C
4	C	C	C	C
5	C	E	E	E

Table 14. Electrical transient requirements (part 3/3)

Class	Contents
C	All functions of the device are performed as designed after exposure to disturbance.
E	One or more functions of the device are not performed as designed after exposure to disturbance and cannot be returned to proper operation without replacing the

Figure 6. Waveforms

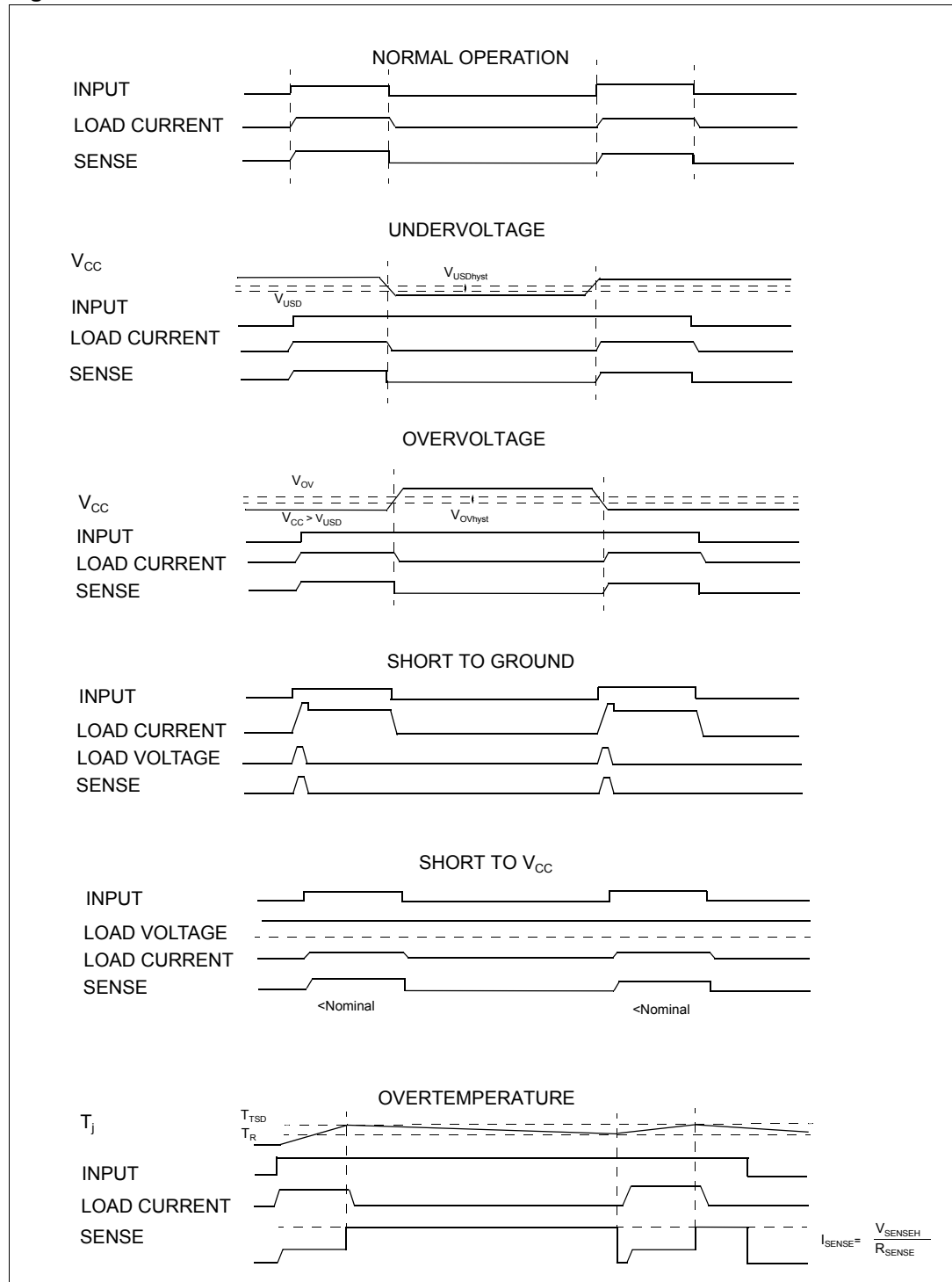

2.4 Electrical characteristics curves

Figure 7. Off-state output current

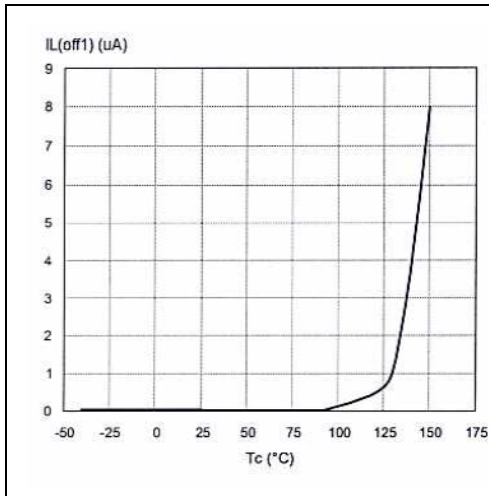

Figure 8. High level input current

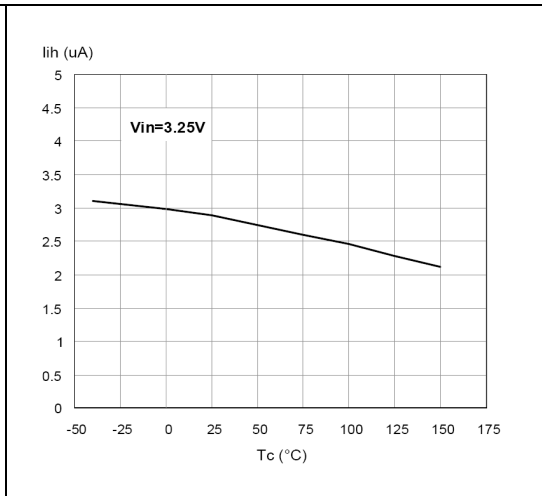

Figure 9. Input clamp voltage

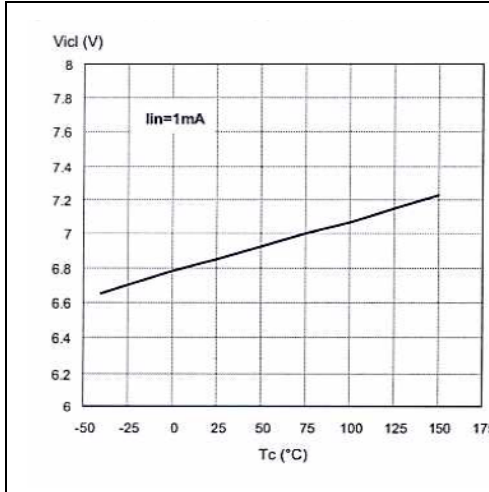

Figure 10. On-state resistance vs V_{CC}

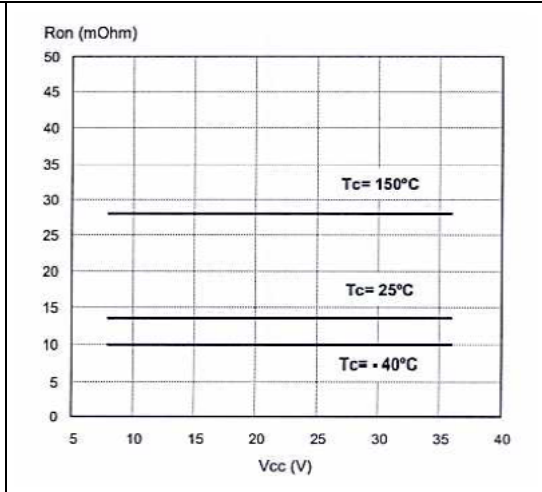

Figure 11. On-state resistance vs T_{CASE}

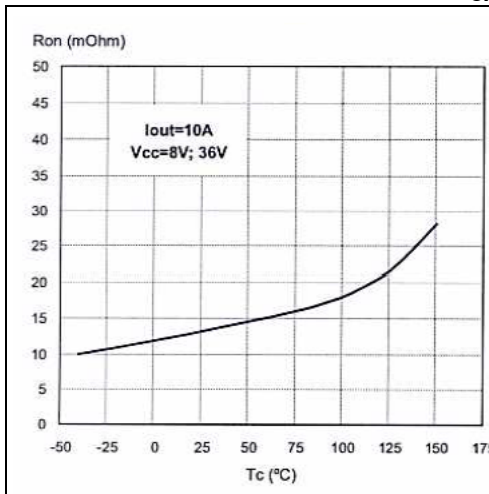

Figure 12. Input high level voltage

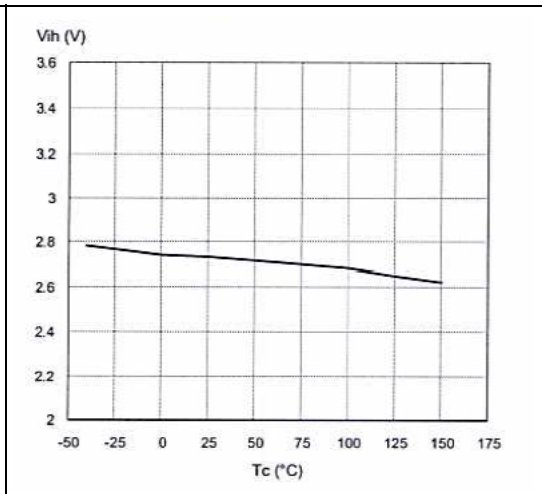

Figure 13. Input low level voltage

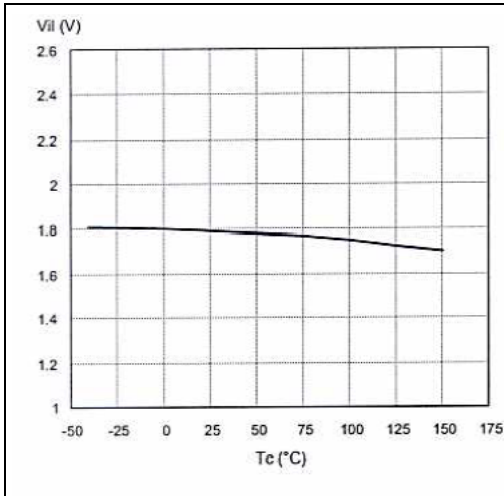

Figure 14. Input hysteresis voltage

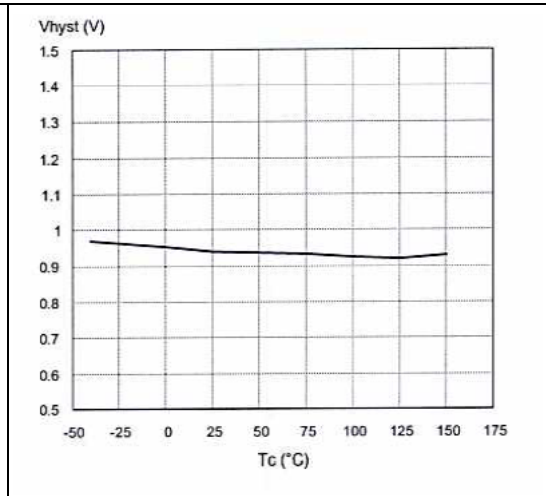

Figure 15. Turn-on voltage slope

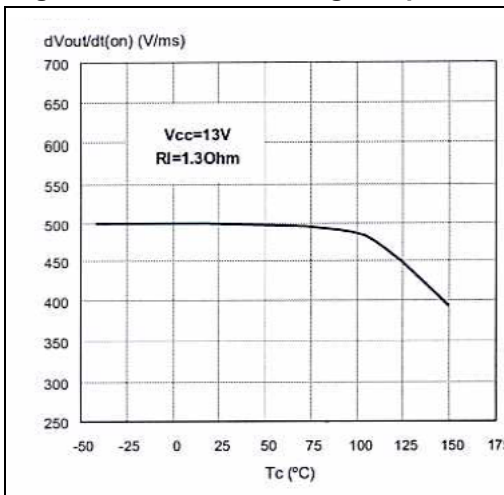

Figure 16. Turn-off voltage slope

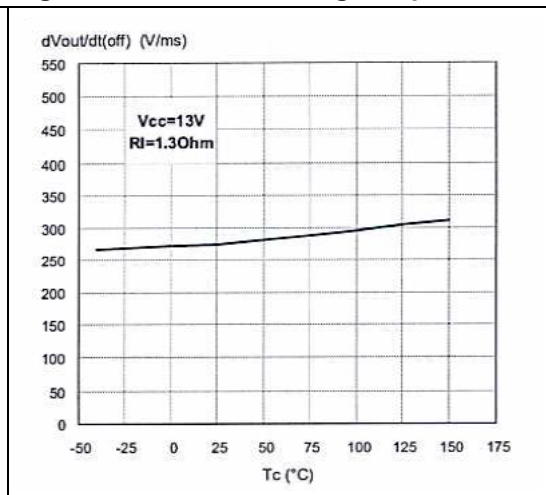

Figure 17. Overvoltage shutdown

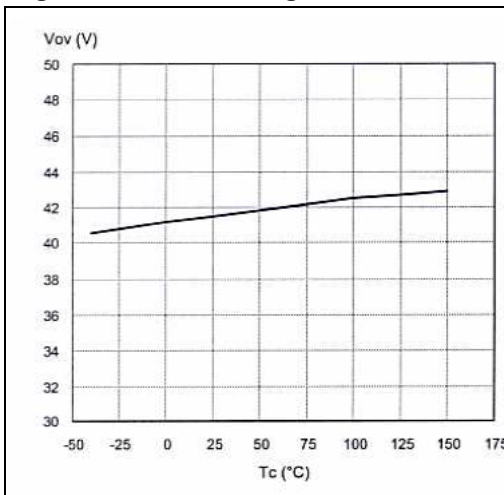
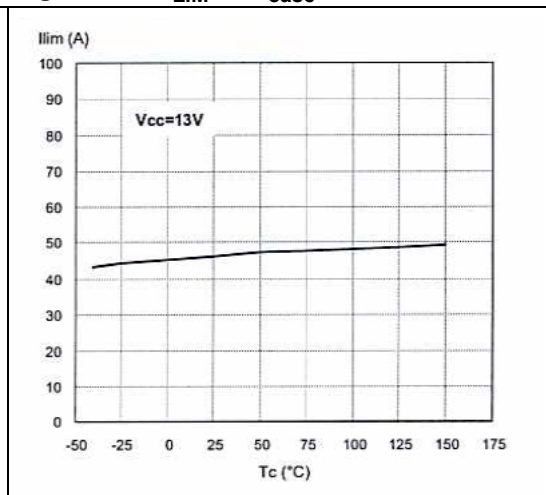
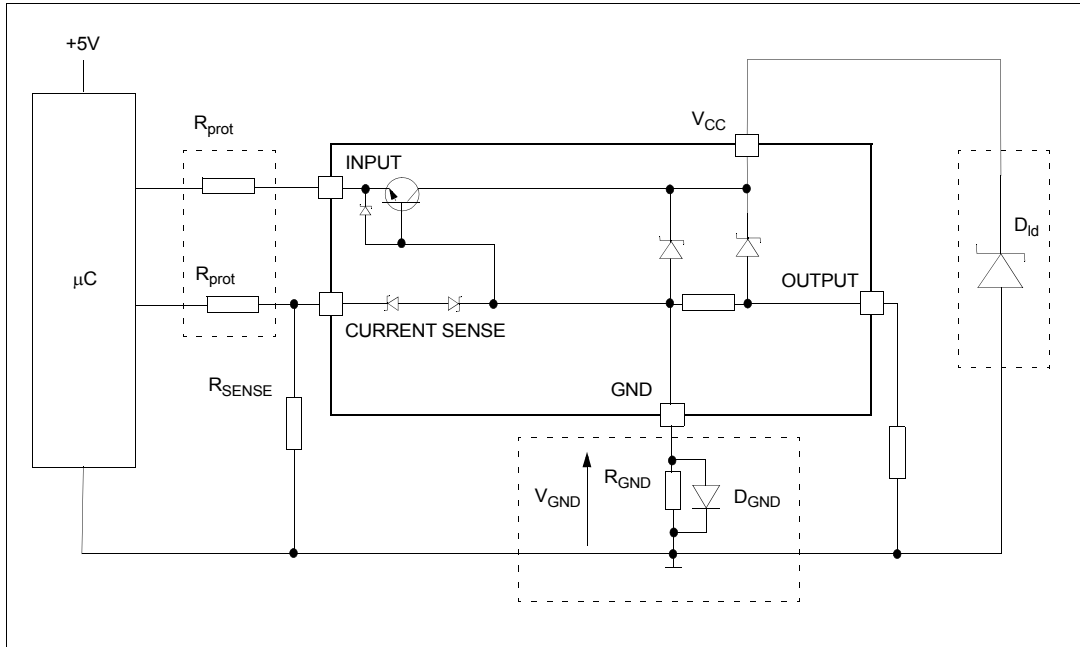

Figure 18. I_{LIM} vs T_{case}



3 Application information

Figure 19. Application schematic



3.1 GND protection network against reverse battery

3.1.1 Solution 1: resistor in the ground line (R_{GND} only)

This can be used with any type of load.

The following is an indication on how to dimension the R_{GND} resistor.

1. $R_{GND} \leq 600\text{mV} / (I_{S(on)max})$.
2. $R_{GND} \geq (-V_{CC}) / (-I_{GND})$

where $-I_{GND}$ is the DC reverse ground pin current and can be found in the absolute maximum rating section of the device datasheet.

Power Dissipation in R_{GND} (when $V_{CC} < 0$: during reverse battery situations) is:

$$P_D = (-V_{CC})^2 / R_{GND}$$

This resistor can be shared amongst several different HSDs. Please note that the value of this resistor should be calculated with formula (1) where $I_{S(on)max}$ becomes the sum of the maximum on-state currents of the different devices.

Please note that if the microprocessor ground is not shared by the device ground then the R_{GND} will produce a shift ($I_{S(on)max} * R_{GND}$) in the input thresholds and the status output values. This shift will vary depending on how many devices are ON in the case of several high-side drivers sharing the same R_{GND} .

If the calculated power dissipation leads to a large resistor or several devices have to share the same resistor then ST suggests to utilize Solution 2 (see below).

3.1.2 Solution 2: diode (D_{GND}) in the ground line

A resistor ($R_{GND} = 1k\Omega$) should be inserted in parallel to D_{GND} if the device drives an inductive load.

This small signal diode can be safely shared amongst several different HSDs. Also in this case, the presence of the ground network will produce a shift ($\approx 600mV$) in the input threshold and in the status output values if the microprocessor ground is not common to the device ground. This shift will not vary if more than one HSD shares the same diode/resistor network.

Series resistor in INPUT lines is also required to prevent that, during battery voltage transient, the current exceeds the absolute maximum rating.

Safest configuration for unused INPUT pin is to leave it unconnected, while unused SENSE pin has to be connected to ground pin.

3.2 Load dump protection

D_{ld} is necessary (voltage transient suppressor) if the load dump peak voltage exceeds the V_{CC} max DC rating. The same applies if the device is subject to transients on the V_{CC} line that are greater than the ones shown in the ISO T/R 7637/1 table.

3.3 MCU I/Os protection

If a ground protection network is used and negative transient are present on the V_{CC} line, the control pins will be pulled negative. ST suggests to insert a resistor (R_{prot}) in line to prevent the μC I/Os pins to latch-up.

The value of these resistors is a compromise between the leakage current of μC and the current required by the HSD I/Os (Input levels compatibility) with the latch-up limit of μC I/Os.

$$-V_{CCpeak}/I_{latchup} \leq R_{prot} \leq (V_{OH\mu C} - V_{IH} - V_{GND}) / I_{IHmax}$$

Calculation example:

For $V_{CCpeak} = -100V$ and $I_{latchup} \geq 20mA$; $V_{OH\mu C} \geq 4.5V$

$$5k\Omega \leq R_{prot} \leq 65k\Omega.$$

Recommended values: $R_{prot} = 10k\Omega$.

4 Package and packing information

4.1 ECOPACK[®] packages

In order to meet environmental requirements, ST offers these devices in different grades of ECOPACK[®] packages, depending on their level of environmental compliance. ECOPACK[®] specifications, grade definitions and product status are available at: www.st.com.

ECOPACK[®] is an ST trademark.

4.1.1 PENTAWATT (vertical) mechanical data

Figure 20. PENTAWATT (vertical) package dimensions

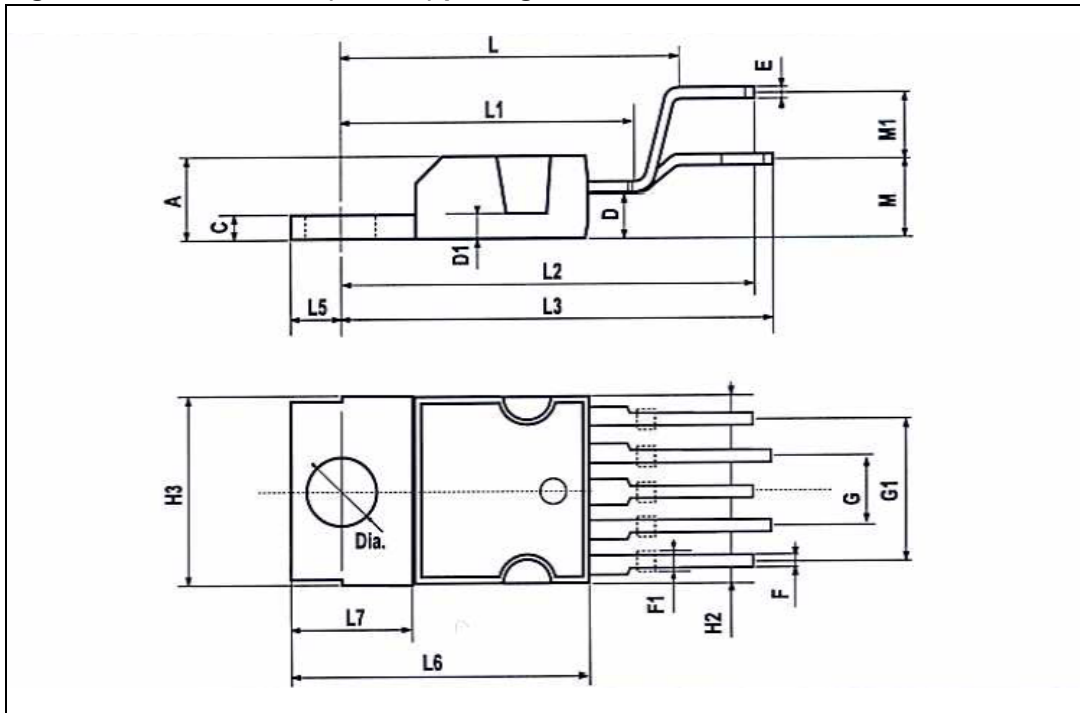

Table 15. PENTAWATT (vertical) mechanical data

Symbol	millimeters		
	Min	Typ	Max
A			4.8
C			1.37
D	2.4		2.8
D1	1.2		1.35
E	0.35		0.55
F	0.8		1.05

Table 15. PENTAWATT (vertical) mechanical data (continued)

Symbol	millimeters		
	Min	Typ	Max
F1	1		1.4
G	3.2	3.4	3.6
G1	6.6	6.8	7
H2			10.4
H3	10.05		10.4
L		17.85	
L1		15.75	
L2		21.4	
L3		22.5	
L5	2.6		3
L6	15.1		15.8
L7	6		6.6
M		4.5	
M1		4	
Diam.	3.65		3.85

4.1.2 PENTAWATT (in-line) mechanical data

Figure 21. PENTAWATT (in-line) package dimensions

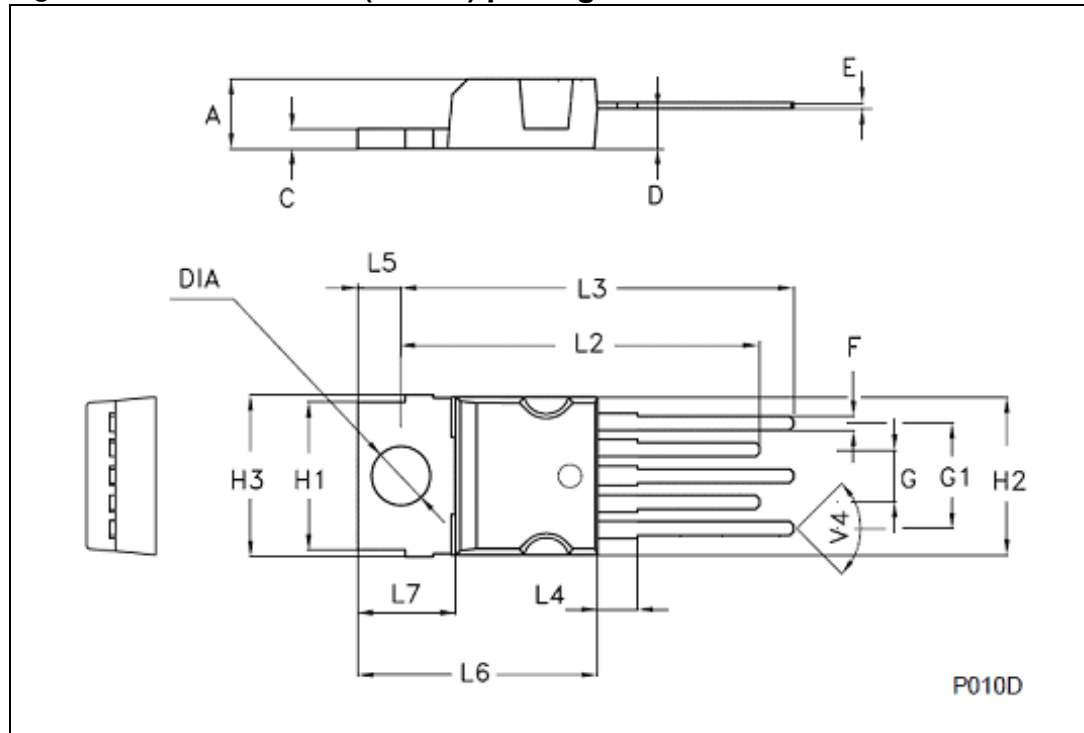

Table 16. PENTAWATT (in-line) mechanical data

Symbol	millimeters		
	Min	Typ	Max
A	4.3		4.8
C	1.17		1.37
D	2.4		2.8
E	0.35		0.55
F	0.8		1.05
F2	1.1		1.4
F3	1.25		1.55
G	3.2		3.6
G1	6.6		7
H1	9.3		9.7
H2			10.4
H3	10.05		10.4
L2	23.05		23.8
L3	25.3		

Table 16. PENTAWATT (in-line) mechanical data (continued)

Symbol	millimeters		
	Min	Typ	Max
L4	0.9		2.9
L5	2.6		3
L6	15.1		15.8
L7	6		6.6
V4		90°	
Diam.	3.65		3.85

4.2 PENTAWATT packing information

Figure 22. PENTAWATT tube shipment (no suffix)

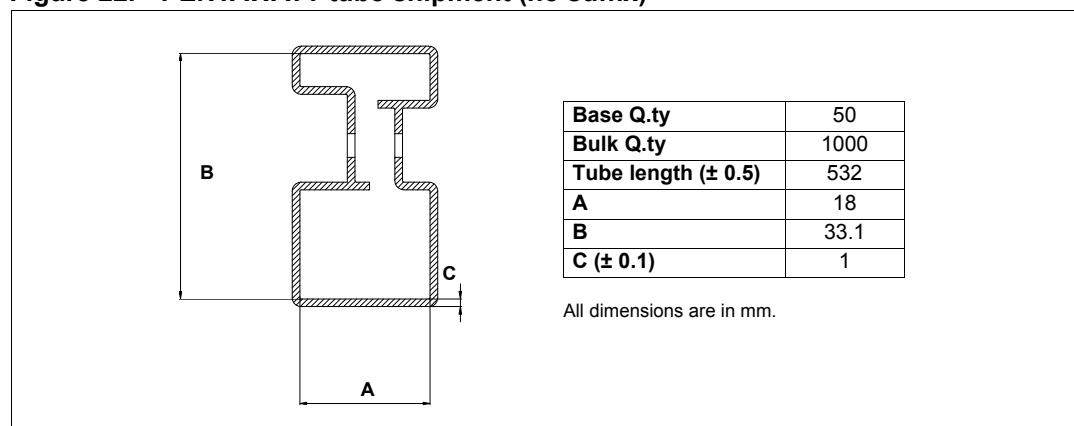

5 Revision history

Table 17. Document revision history

Date	Revision	Changes
22-Oct-2004	1	Initial release.
22-Sep-2009	2	Removed all the references to VN920B5-E and VN920SO-E
08-Oct-2009	3	Added PENTAWATT in-line package: – Updated Table 1: Device summary . – Added Section 4.1.2: PENTAWATT (in-line) mechanical data .
20-Sep-2013	4	Updated Disclaimer.

Please Read Carefully:

Information in this document is provided solely in connection with ST products. STMicroelectronics NV and its subsidiaries ("ST") reserve the right to make changes, corrections, modifications or improvements, to this document, and the products and services described herein at any time, without notice.

All ST products are sold pursuant to ST's terms and conditions of sale.

Purchasers are solely responsible for the choice, selection and use of the ST products and services described herein, and ST assumes no liability whatsoever relating to the choice, selection or use of the ST products and services described herein.

No license, express or implied, by estoppel or otherwise, to any intellectual property rights is granted under this document. If any part of this document refers to any third party products or services it shall not be deemed a license grant by ST for the use of such third party products or services, or any intellectual property contained therein or considered as a warranty covering the use in any manner whatsoever of such third party products or services or any intellectual property contained therein.

UNLESS OTHERWISE SET FORTH IN ST'S TERMS AND CONDITIONS OF SALE ST DISCLAIMS ANY EXPRESS OR IMPLIED WARRANTY WITH RESPECT TO THE USE AND/OR SALE OF ST PRODUCTS INCLUDING WITHOUT LIMITATION IMPLIED WARRANTIES OF MERCHANTABILITY, FITNESS FOR A PARTICULAR PURPOSE (AND THEIR EQUIVALENTS UNDER THE LAWS OF ANY JURISDICTION), OR INFRINGEMENT OF ANY PATENT, COPYRIGHT OR OTHER INTELLECTUAL PROPERTY RIGHT.

ST PRODUCTS ARE NOT DESIGNED OR AUTHORIZED FOR USE IN: (A) SAFETY CRITICAL APPLICATIONS SUCH AS LIFE SUPPORTING, ACTIVE IMPLANTED DEVICES OR SYSTEMS WITH PRODUCT FUNCTIONAL SAFETY REQUIREMENTS; (B) AERONAUTIC APPLICATIONS; (C) AUTOMOTIVE APPLICATIONS OR ENVIRONMENTS, AND/OR (D) AEROSPACE APPLICATIONS OR ENVIRONMENTS. WHERE ST PRODUCTS ARE NOT DESIGNED FOR SUCH USE, THE PURCHASER SHALL USE PRODUCTS AT PURCHASER'S SOLE RISK, EVEN IF ST HAS BEEN INFORMED IN WRITING OF SUCH USAGE, UNLESS A PRODUCT IS EXPRESSLY DESIGNATED BY ST AS BEING INTENDED FOR "AUTOMOTIVE, AUTOMOTIVE SAFETY OR MEDICAL" INDUSTRY DOMAINS ACCORDING TO ST PRODUCT DESIGN SPECIFICATIONS. PRODUCTS FORMALLY ESCC, QML OR JAN QUALIFIED ARE DEEMED SUITABLE FOR USE IN AEROSPACE BY THE CORRESPONDING GOVERNMENTAL AGENCY.

Resale of ST products with provisions different from the statements and/or technical features set forth in this document shall immediately void any warranty granted by ST for the ST product or service described herein and shall not create or extend in any manner whatsoever, any liability of ST.

ST and the ST logo are trademarks or registered trademarks of ST in various countries.

Information in this document supersedes and replaces all information previously supplied.

The ST logo is a registered trademark of STMicroelectronics. All other names are the property of their respective owners.

© 2013 STMicroelectronics - All rights reserved

STMicroelectronics group of companies

Australia - Belgium - Brazil - Canada - China - Czech Republic - Finland - France - Germany - Hong Kong - India - Israel - Italy - Japan - Malaysia - Malta - Morocco - Philippines - Singapore - Spain - Sweden - Switzerland - United Kingdom - United States of America

www.st.com