



SANYO Semiconductors

DATA SHEET

LV8224T — Bi-CMOS LSI Motor driver system in CD and MD players

Overview

The LV8224T is a system motor driver IC that implements all the motor driver circuits needed for CD and MD products. The LV8224T provides a three-phase PWM spindle driver, a sled driver (either three-phase or PWM H bridge operation can be selected), and focus and tracking drivers (as two PWM H bridge driver channels). Since the LV8224T uses BiCDMOS devices, it can contribute to further miniaturization, thinner form factors, and lower power in end products. The adoption of the direct PWM sensorless drive method for the spindle driver makes it possible to implement high efficiency motor drive with few external parts.

Features

- PWM H bridge motor drivers (2 channels)
- Three-phase stepping motor driver, and direct PWM sensorless motor driver

Specifications

Absolute Maximum Ratings at $T_a = 25^\circ\text{C}$

Parameter	Symbol	Conditions	Ratings	Unit
Supply voltage	$V_{CC\ max}$		5.0	V
Output block power supply voltage	$V_S\ max$		4.5	V
Predriver voltage (gate voltage)	$V_G\ max$		6.5	V
Output current	$I_O\ max$		0.8	A
Allowable power dissipation	$P_d\ max1$	Independent IC	0.4	W
	$P_d\ max2$	* Mounted on a board.	1.1	W
Operating temperature	T_{opr}		-30 to +85	$^\circ\text{C}$
Storage temperature	T_{stg}		-55 to +150	$^\circ\text{C}$

* : Mounted on a board : 50×50×1.6mm³, glass epoxy board

■ Any and all SANYO Semiconductor Co.,Ltd. products described or contained herein are, with regard to "standard application", intended for the use as general electronics equipment (home appliances, AV equipment, communication device, office equipment, industrial equipment etc.). The products mentioned herein shall not be intended for use for any "special application" (medical equipment whose purpose is to sustain life, aerospace instrument, nuclear control device, burning appliances, transportation machine, traffic signal system, safety equipment etc.) that shall require extremely high level of reliability and can directly threaten human lives in case of failure or malfunction of the product or may cause harm to human bodies, nor shall they grant any guarantee thereof. If you should intend to use our products for applications outside the standard applications of our customer who is considering such use and/or outside the scope of our intended standard applications, please consult with us prior to the intended use. If there is no consultation or inquiry before the intended use, our customer shall be solely responsible for the use.

■ Specifications of any and all SANYO Semiconductor Co.,Ltd. products described or contained herein stipulate the performance, characteristics, and functions of the described products in the independent state, and are not guarantees of the performance, characteristics, and functions of the described products as mounted in the customer's products or equipment. To verify symptoms and states that cannot be evaluated in an independent device, the customer should always evaluate and test devices mounted in the customer's products or equipment.

SANYO Semiconductor Co., Ltd.

TOKYO OFFICE Tokyo Bldg., 1-10, 1 Chome, Ueno, Taito-ku, TOKYO, 110-8534 JAPAN

LV8224T

Recommended operating Ranges at Ta = 25°C

Parameter	Symbol	Conditions	Ratings	Unit
Supply voltage	V _{CC}		1.9 to 4.0	V
Output block supply voltage	VS		0 to VG-3.0	V
Predriver voltage (gate voltage)	VG		VS+3 to 6.3	V

Electrical Characteristics at Ta = 25°C, V_{CC} = 2.3V

Parameter	Symbol	Conditions	min	typ	max	Unit
Current drain 1	I _{CC1}	S/S pin H		1.0	1.5	mA
Current drain 2	I _{CC2}	S/S pin L(at standby)			20	μA
Charge Pump Output						
Output voltage	VG		5.4	5.9	6.2	V
Actuator Block : Ta = 25°C, V_{CC} = 2.3V						
Position Detection Comparator Block						
Input offset voltage	V _{AOFS}		-9		+9	mV
Common-mode input voltage range	V _{ACM}		0		V _{CC}	V
High-level output voltage	V _{ACh}	I _O = -0.5mA	V _{CC} -0.5		V _{CC}	V
Low-level output voltage	V _{ACL}	I _O = 0.5mA			0.5	V
Output block (OUT1F/R, OUT2F/R, SUO to SWO pins)						
SOURCE 1	Ron (H1)	I _O = 0.5A, VS = 1.2V, VG = 6V, forward drive transistor		0.4	0.6	Ω
SOURCE 2	Ron (H2)	I _O = 0.5A, VS = 1.2V, VG = 6V, reverse drive transistor		0.4	0.6	Ω
SINK	Ron (L)	I _O = 0.5A, VS = 1.2V, VG = 6V		0.4	0.6	Ω
SOURCE+SINK	Ron (H+L)	I _O = 0.5A, VS = 1.2V, VG = 6V		0.8	1.2	Ω
Output transmission delay time (H bridge)	T _{RISE}	*Design target		0.1	1.0	μs
	T _{FALL}	*Design target		0.1	0.7	μs
Minimum input pulse width (H bridge)	t _{min}	ch1, 2 output pulse width ≥ 2/3t _{min} *Design target	200			ns
Decoder and Actuator Input Pins (IN1F/R, IN2F/R, S1 to S3 pins)						
High-level input voltage range	V _{IH}		V _{CC} -0.5		V _{CC}	V
Low-level input voltage range	V _{IL}		0		0.5	V
High-level actuator input pin current	I _{INH}	When input pin voltage is 2.3V	9.5		13	μA
Low-level actuator input pin current	I _{INL}	When input pin voltage is 0V			1	μA
MUTE Pin						
High-level input voltage range	V _{MUH}	MUTE OFF	V _{CC} -0.5		V _{CC}	V
Low-level input voltage range	V _{MUL}	MUTE ON	0		0.5	V
High-level input pin current	I _{MUTEH}	When input pin voltage is 2.3V	9.5		13	μA
Low-level input pin current	I _{MUTEL}	When input pin voltage is 0V			1	μA
Spindle Motor Driver block : Ta = 25°C, V_{CC} = 2.3V						
Output Block						
SOURCE1	Ron (H1)	I _O = 0.5A, VS = 1.2V, VG = 6V, forward drive transistor		0.4	0.6	Ω
SOURCE2	Ron (H2)	I _O = 0.5A, VS = 1.2V, VG = 6V, reverse drive transistor		0.4	0.6	Ω
SINK	Ron (L)	I _O = 0.5A, VS = 1.2V, VG = 6V		0.4	0.6	Ω
SOURCE+SINK	Ron (H+L)	I _O = 0.5A, VS = 1.2V, VG = 6V		0.8	1.2	Ω
Position Detector Comparator						
Input offset voltage	V _{SOFS}		-9		9	mV
Startup Oscillator Pin						
OSC high-level voltage	V _{OSCH}		0.85	1.05	1.25	V
OSC low-level voltage	V _{OSCL}		0.40	0.60	0.80	V
S/S pin						
High-level input voltage range	V _{SSH}	Start	V _{CC} -0.5		V _{CC}	V
Low-level input voltage range	V _{SSL}	Stop	0		0.5	V
High-level input pin current	I _{SSH}	When input pin voltage is 2.3V	9.5		13	μA
Low-level input pin current	I _{SSL}	When input pin voltage is 0V			1	μA

Continued on next page.

LV8224T

Continued from preceding page.

Parameter	Symbol	Conditions	min	typ	max	Unit
BREAK Pin						
High-level input voltage range	V _{BRH}	Brake off	V _{CC} -0.5		V _{CC}	V
Low-level input voltage range	V _{BRL}	Brake on	0		0.5	V
High-level input pin current	I _{BRKH}	When input pin voltage is 2.3V	9.5		13	μA
Low-level input pin current	I _{BRKL}	When input pin voltage is 0V			1	μA
PWM Pin						
High-level input voltage range	V _{PWMH}		V _{CC} -0.5		V _{CC}	V
Low-level input voltage range	V _{PWML}		0		0.5	V
High-level input pin current	I _{PWMH}	When input pin voltage is 2.3V	9.5		13	μA
Low-level input pin current	I _{PWML}	When input pin voltage is 0V			1	μA
PWM input frequency	V _{PWMIN}				190	kHz
CLK Pin						
High-level input voltage range	V _{CLKH}		V _{CC} -0.5		V _{CC}	V
Low-level input voltage range	V _{CLKL}		0		0.5	V
High-level input pin current	I _{CLKH}	When input pin voltage is 2.3V	9.5		13	μA
Low-level input pin current	I _{CLKL}	When input pin voltage is 0V			1	μA
FG output Pin						
High-level output voltage	V _{FGH}	I _O = -0.5mA	V _{CC} -0.5		V _{CC}	V
Low-level output voltage	V _{FGL}	I _O = 0.5mA			0.5	V

Package Dimensions

unit : mm (typ)

3254

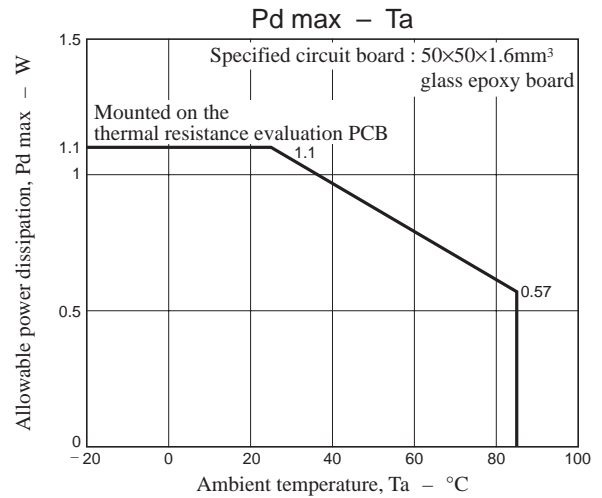
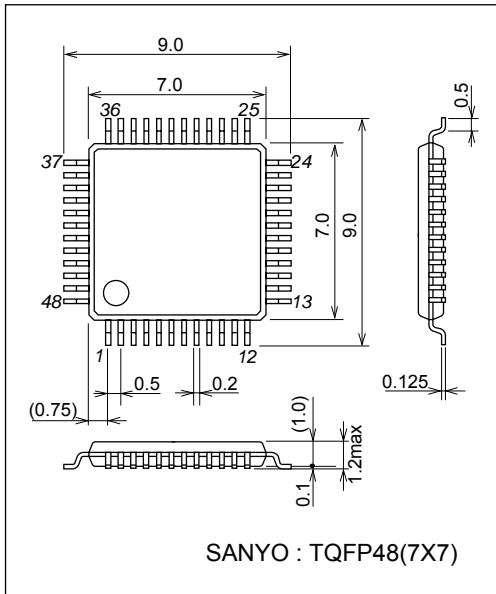

LV8224T

Actuator Truth Tables

Focus and Tracking Blocks

MUTE	IN1, 2F	IN1, 2R	OUT1, 2F	OUT1, 2R
H	L	L	L	L
H	H	L	H	L
H	L	H	L	H
H	H	H	L	L
L	x	x	Z	Z

Sled Drive Block Stepping Drive Mode (When 3/H pin (pin 47) is high)

MUTE	S1	S2	S3	SUO	SVO	SWO
H	L	L	L	H	L	Z
H	H	L	L	H	Z	L
H	L	H	L	Z	H	L
H	H	H	L	L	H	Z
H	L	L	H	L	Z	H
H	H	L	H	Z	L	H
H	L	H	H	Z	Z	Z
H	H	H	H	Z	Z	Z
L	x	x	x	Z	Z	Z

Z : Open

Sled Drive Block H Bridge Drive Mode (When 3/H pin (pin 47) is low)

MUTE	S1	S2	SUO	SVO
H	L	L	L	L
H	H	L	H	L
H	L	H	L	H
H	H	H	L	L
L	x	x	Z	Z

MUTE	S3	SWO
H	L	L
H	H	H
L	x	Z

Z : Open

Notes :

When the 3/H pin is set to select H bridge mode, SUO and SVO operate as PWM H bridge outputs according to the S1 and S2 inputs, and SWO operates as a half-bridge circuit output according to the S3 input.

LV8224T

Pin Assignment

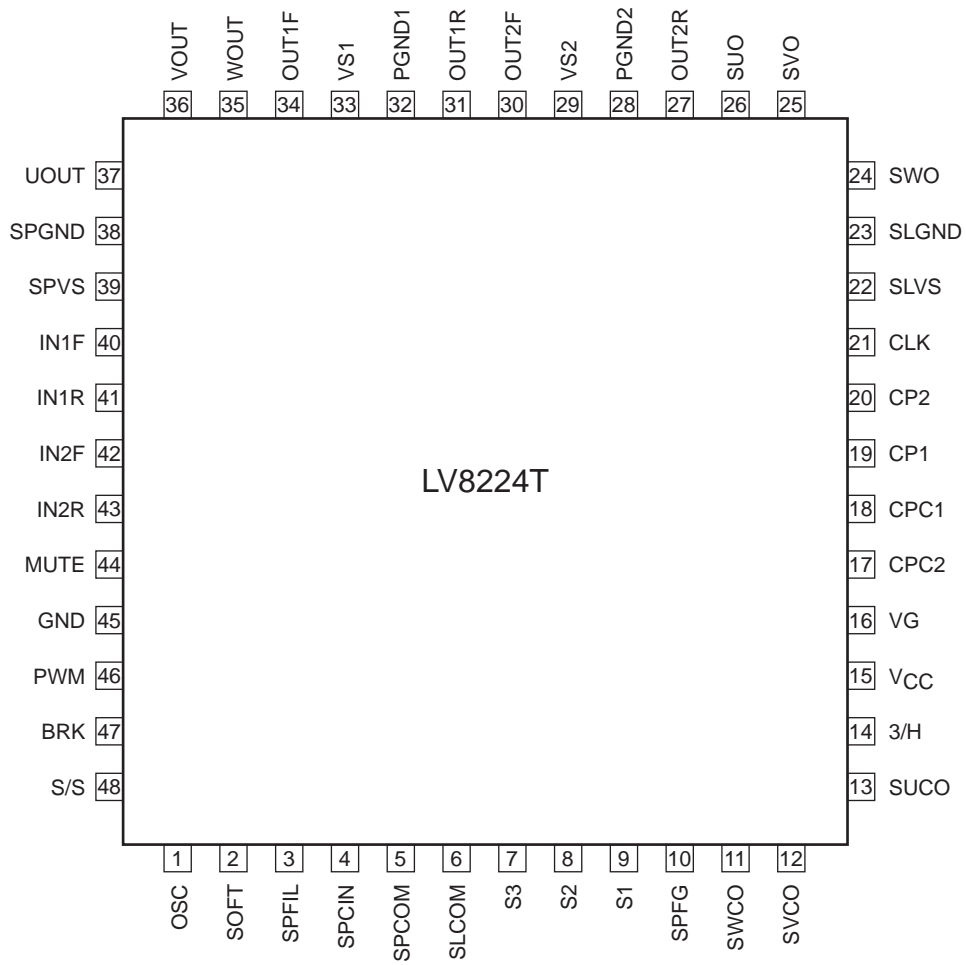

LV8224T

Block Diagram

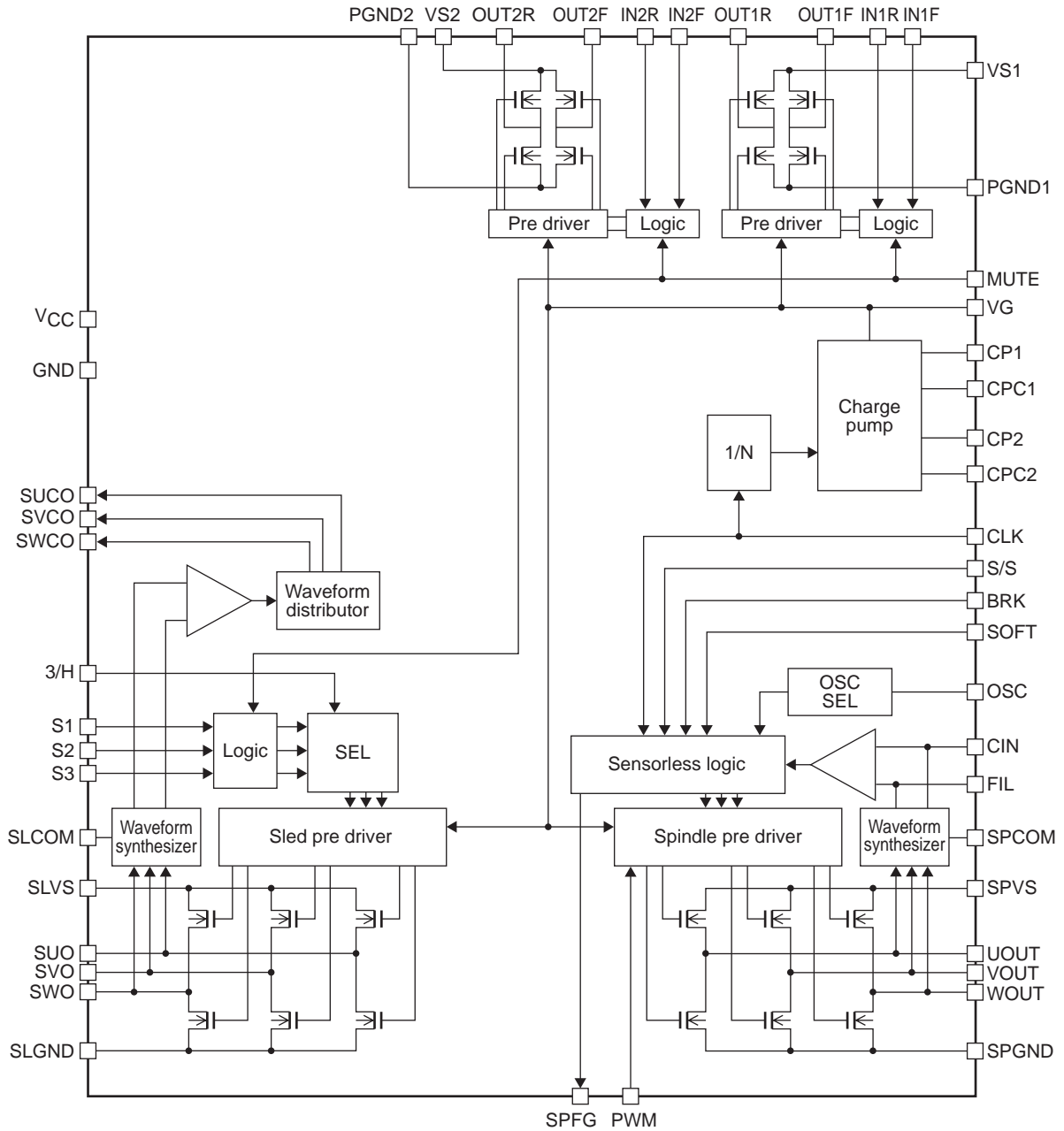

LV8224T

Sample Application Circuit 1

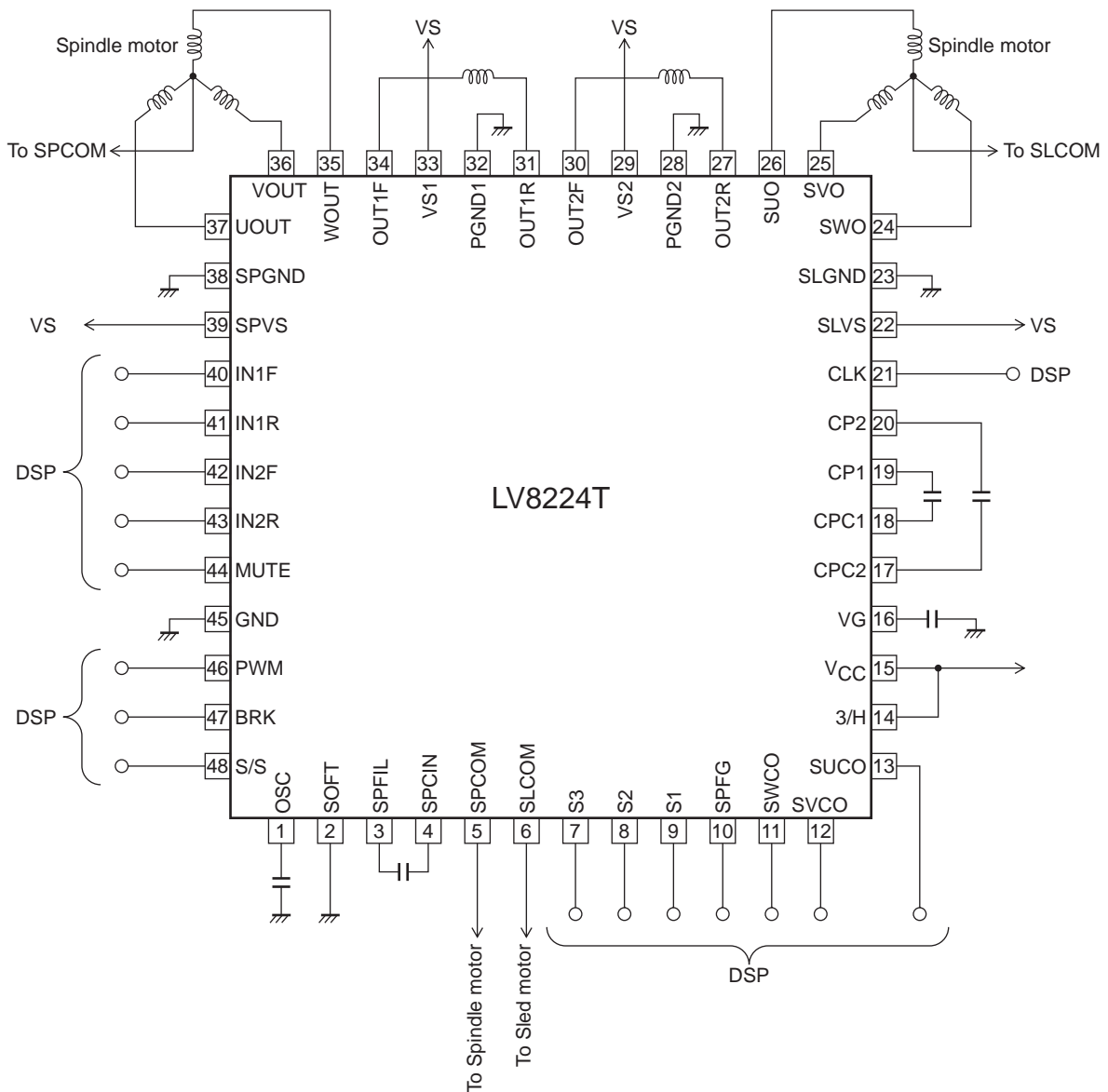

Notes

- Startup with automatic oscillation mode
- Sled three-phase stepping mode
- Cored motor spindle motor mode

Capacitors must be inserted between VS and PGND, and between V_{CC} and ground.

LV8224T

Sample Application Circuit 2

External parts minimum plan

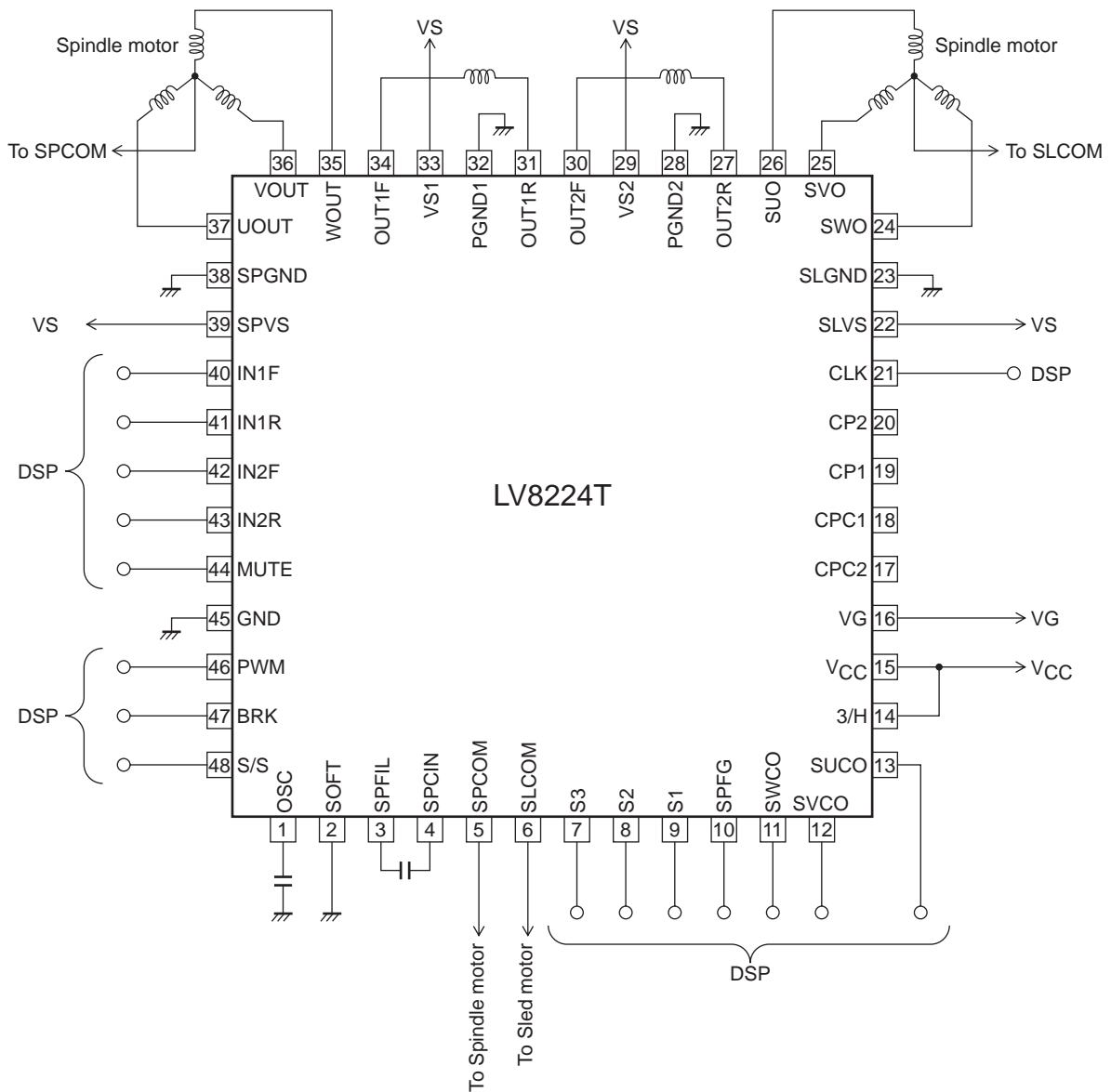

Notes

- Startup with internal oscillation control mode (Low-level selected)
- Sled three-phase stepping mode
- Cored motor spindle motor mode
- External stepped-up power supply used

Capacitors must be inserted between each VS and ground, Between each VCC and ground, and between each VG and ground.

LV8224T

Continued from preceding page.

Pin No.	Pin name	Pin circuit	Equivalent Circuit
6	SLCOM	Sled driver block position detection comparator common input.	
9 8 7	S1 S2 S3	Three-phase sled block logic inputs. Pins 35, 36, and 37 are the corresponding outputs.	
10	SPFG	FG pulse output. This pin outputs a three Hall sensor system equivalent pulse signal.	
13 12 11	SUCO SVCO SWCO	Sled driver block position detection comparator outputs.	
14	3/H	Sled drive mode selection. A high-level input selects three-phase stepping mode, and a low-level input selects H-bridge + half bridge mode. This pin must not be left open.	
15	VCC	Small-signal system power supply. Insert a capacitor between this pin and ground.	
16	VG	Charge pump stepped up voltage output. Insert a capacitor between this pin and ground.	
17	CPC2	Charge pump step-up connection. Insert a capacitor between this pin and CP2 (pin 20).	
18	CPC1	Charge pump step-up connection. Insert a capacitor between this pin and CP1 (pin 19).	

Continued on next page.

LV8224T

Continued from preceding page.

Pin No.	Pin name	Pin circuit	Equivalent Circuit
19	CP1	Charge pump step-up pulse output. Insert a capacitor between this pin and CPC1 (pin 18). Leave this pin open when using this circuit as a 2x step-up circuit.	
20	CP2	Charge pump step-up pulse output. Insert a capacitor between this pin and CPC2 (pin 17).	
21	CLK	Logic circuit operation reference clock input. Supply a frequency 32 times that of the spindle PWM frequency.	
40, 41 42, 43	IN1F/R IN2F/R	Actuator H-bridge block logic input.	
44	MUTE	Muting control for the H bridge 1 and 2 blocks and the sled driver block. When a low level is input, these channel outputs all go to the high-impedance state.	
46	PWM	PWM signal input. The output transistor is on when this input is high.	
47	BRK	Spindle motor block braking control. A low-level input sets the block to reverse torque braking.	
48	S/S	Spindle motor block start/stop control. A high-level input sets the block to start mode.	
22	SLVS	Sled motor drive power supply. Insert a capacitor between this pin and ground.	
26 25 24	SUO SVO SWO	Sled driver outputs. Connect these pins to the sled motor.	
23	SLGND	Sled output block ground.	
29 30, 27 28	VS2 OUT2F/R PGND2	H bridge 2 output block. Insert a capacitor between VS2 (pin 29) and ground.	
33 34, 31 32	VS1 OUT1F/R PGND1	H-bridge 1 output block. Insert a capacitor between VS1 (pin 33) and ground.	

Continued on next page.

LV8224T

Continued from preceding page.

Pin No.	Pin name	Pin circuit	Equivalent Circuit
39	SPVS	Spindle motor drive power supply. Insert a capacitor between this pin and ground.	
37	UOUT	Spindle driver outputs. Connect these pins to the spindle motor.	
36	VOUT		
35	WOUT		
38	SPGND	Spindle output block ground.	
45	GND	Small-signal system circuit ground.	

LV8224T Functional Description and Notes on External Components

The LV8224T is a system driver IC that implements, in a single chip, all the motor driver circuits required for CD and MD players. Since the LV8224T provides a spindle motor driver (three-phase PWM sensorless drive), a sled stepping motor driver that supports either three-phase stepping or PWM H-bridge drive, and two PWM H-bridge drivers for the focus and tracking blocks, it can contribute to thinner form factors and further miniaturization in end products. Since the spindle motor driver uses a direct PWM sensorless drive technique, it achieves high-efficiency motor drive with a minimal number of external components.

Read the following notes before designing driver circuits using the LV8224T to design a system with fully satisfactory characteristics.

1. Output Drive Circuit and Speed Control Methods

The LV8224T adopts the synchronous commutation direct PWM drive method to minimize power loss in the output circuits. Low on-resistance DMOS devices (total high and low side on-resistance : 0.8Ω, typical) are used as the output transistors.

The spindle motor driver speed is controlled by BRK and PWM signals provided by an external DSP. The PWM signal controls the sink side transistor. That transistor is switched according to the input duty of the signal input to the PWM pin (pin 46) to control the motor speed. (The sink side transistor is on when the PWM input is high-level, and off when the PWM input is low-level.)

The LV8224T also uses variable duty soft switching to achieve quieter motor drive.

2. Soft Switching Mode Selection

The LV8224T spindle drive block uses variable PWM duty soft switching to reduce motor drive noise. The SOFT pin (pin 2) selects the soft switching drive mode, that is, it selects different conditions for optimally quiet drive depending on the motor structure (coil inductance). Set the SOFT pin to the high-level for coreless motors (motors with a low inductance) and to the low-level for cored motors (motors with a high inductance) for optimal soft switching.

Although the SOFT pin has an MOS input circuit, it does not have a built-in pull-up or pull-down resistor, and thus must be set to the high or low level. This pin must not be left open.

3. S/S and MUTE Circuits

The S/S pin (pin 48) functions as the spindle motor driver's start/stop pin; a high-level input specifies that the operation is in the start state. The MUTE pin (pin 44) operates on all driver blocks other than the spindle block; a low-level input mutes these outputs. In the muted state, the corresponding drivers (H-bridge and three-phase sled drivers) all go to the high-impedance state, regardless of the states of the logic inputs. Since the S/S and MUTE pins operate independently, low-level inputs must be applied to both the S/S and MUTE pins to set the IC to the standby state (power saving mode).

4. Braking Circuit

The BRK pin (pin 47) switches the direction of the torque applied by the spindle motor driver; when a low-level is applied to the BRK pin, the driver switches to the reverse torque braking mode. When the motor decelerates to an adequately low speed in the reverse torque braking mode, the driver switches to the short-circuit braking mode to stop the motor. (Note : the IC cannot be set to low-power mode at this time.)

5. Notes on the CLK and PWM Signals

The LV8224T CLK pin (pin 21) is used as the sensorless logic reference clock, for step-up circuit pulse generation, and for other purposes. Therefore, the CLK signal must be supplied at all times when the LV8224T is in start mode. The CLK input signal must have a frequency 32 times that of the PWM input signal. We recommend that the CLK input frequency be less than 6MHz.

6. FG Output Circuit

The SPFG pin (pin 10) is the spindle block FG output. It outputs a pulse signal equivalent to a three Hall sensor FG output. This output has an MOS circuit structure.

7. Spindle Block Position Detection Comparator Circuit

The spindle block position detection comparator circuit is provided to detect the position of the rotor using the back EMF generated when the motor turns. The IC determines the timing with which the output block applies current to the motor based on the position information acquired by this circuit. Startup problems due to comparator input noise can be resolved by inserting a capacitor (about 1000 to 4700pF) between the SPCIN pin (pin 4) and the SPFIL pin (pin 3). Note that if this capacitor is too large, the output commutation timing may be delayed at higher speeds and efficiency may be reduced.

8. OSC Circuit

The OSC pin (pin 1) is an oscillator pin provided for sensorless motor startup commutation. The LV8224T provides two main clock dividing modes and a self-oscillation mode.

The main clock division modes are selected by connecting OSC pin to either V_{CC} or ground. The startup frequency is created by dividing the signal input to the CLK pin (pin 21), and is either CLK/4096 (when the OSC pin is connected to V_{CC}) or CLK/3072 (when the OSC pin is connected to ground). Self-oscillation mode is set up by inserting a capacitor between the OSC pin and ground. When self-oscillation mode is selected, the OSC pin starts self-oscillating, and that frequency becomes the startup frequency. The oscillator frequency can be adjusted by changing the value of the external capacitor (reducing the value of the capacitor increases the startup frequency). The number of external components can be reduced if there are no problems with the startup characteristics when the OSC pin is connected to either V_{CC} or ground. However, if there are problems, select self-oscillation mode and select a value of the capacitor that provides optimal startup characteristics.

9. Charge Pump Circuit

The LV8224T n-channel DMOS output structure allows it to provide a charge pump based voltage step-up circuit. A voltage 3 times the V_{CC} voltage (or about 6.0V) can be acquired from the VG pin (pin 16) by inserting capacitors (recommended value : 0.1μF or larger) between the CP1 (pin 19) and CPC1 (pin 18) pins and between the CP2 (pin 20) and CPC2 (pin 17) pins. We recommend using this circuit with values such that the voltage relationship between the stepped-up voltage (VG) and the motor supply voltage (VS) is $VG - VS \geq 3.0V$. Note that this circuit is designed so that the stepped-up voltage (VG) is clamped at about 6.0VDC. A larger capacitor must be used on the VG pin if the ripple on the stepped-up voltage (VG) results in VG exceeding 6.5V(VG max).

Observe the following points if the VG voltage is supplied from external circuits.

- 1) The VG voltage supplied from the external circuits must not exceed the absolute maximum rating VG max.
- 2) The capacitors between the CP and CPC pins (pins 17 to 20) are not required.
- 3) There is an IC-internal diode between the V_{CC} and VG pins. Therefore, supply voltages such that $V_{CC} > VG$ must never be applied to this IC.

10. Sled Driver

The LV8224T sled driver block provides two output circuit structures: one appropriate for a three-phase motor and one appropriate for a DC motor. Connect the 3/H pin (pin 14) to V_{CC} to set the block to use the three-phase stepping drive structure, and connect the 3/H pin to ground to set the block to use the PWH H bridge drive structure. The S1 to S3 pins (pins 7 to 9) are the sled driver block control inputs, and the signals are supplied by the DSP. The S1 to S3 pins have built-in pull-up resistors.

The SUC0 to SWC0 pins (pins 13, 12, and 11) are the sled driver position detection comparator output pins. These pins output the signals only in the three-phase stepping mode, and they output the low-level potential in standby mode and PWM H bridge mode. These pins are used to feed back the sled motor speed and position information to the DSP or microcontroller.

11. Actuator Block

The LV8224T incorporates two H bridge channels for use as actuator drivers for the focus and tracking systems. The logic input pin circuits incorporates pull-down resistors. A PWM signal is used for control, and the circuit supports synchronous commutation.

The OUT1F/R output (pins 34 and 31) is the output corresponding to the IN1F/R (pins 40 and 41) channel 1 control input, and the OUT2F/R output (pins 30 and 27) is the output corresponding to the IN2F/R (pins 42 and 43) channel 2 control input.

The figures show the dead band characteristics during motor control and the test circuit used for measuring those characteristics.

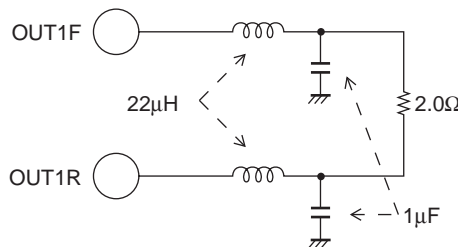
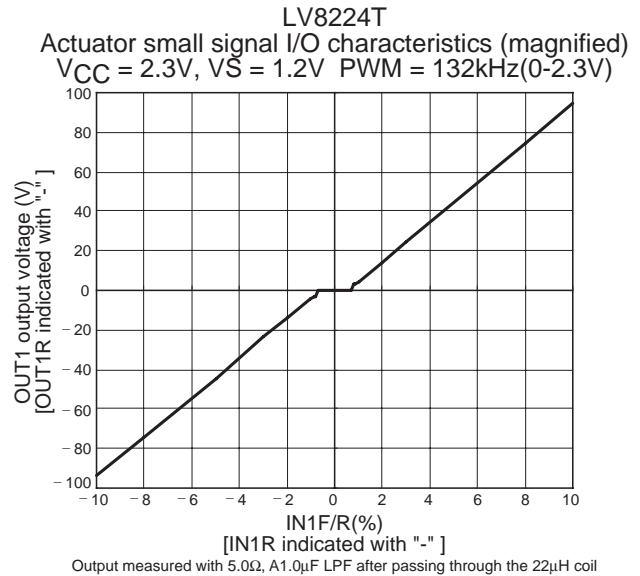
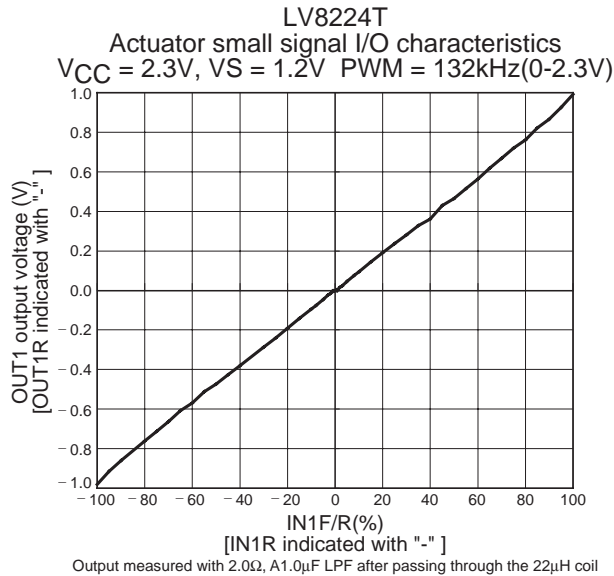

12. Notes on PCB Pattern Design

The LV8224T is a system driver IC implemented in a Bi-CMOS process; the IC chip includes bipolar circuits, MOS logic circuits, and MOS drive circuits integrated on the same chip. As a result, extreme care is required with respect to the pattern layout when designing application circuits.

1) Ground and V_{CC}/V_S wiring layout

The LV8224T ground and power supply pins are classified as follows.

Small-signal system ground pin → GND (pin 45)

Large-signal system ground pins → PGND1 (pin 32), PGND2 (pin 28), SPGND (pin 38), SLGND (pin 23)

Small-signal system power supply pin → V_{CC} (pin 15)

Large-signal system power supply pins → VS1 (pin 33), VS2 (pin 29), SPVS (pin 39), SLVS (pin 22)

A capacitor must be inserted, as close as possible to the IC, between the small-signal system power supply pin (pin 15) and ground pin (pin 45).

The large-signal system ground pins (PGND1, PGND2, SPGND, and SLGND) must be connected with the shortest possible lines, and furthermore in a manner such that there is no shared impedance with the small-signal system ground lines. Capacitors must also be inserted, as close as possible to the IC, between the large-signal system power supply pins (VS1, VS2, SPVS, and SLVS) and the corresponding large-signal system ground pins.

2) Positioning the small-signal system external components

The small-signal system external components that are also connected to ground must be connected to the small-signal system ground with lines that are as short as possible.

3) Notes on components connected between IC pins

External components connected between IC pins must be connected using the shortest lines possible.

The capacitor between CP1 (pin 19) and CPC1 (pin 18)

The capacitor between CP2 (pin 20) and CPC2 (pin 17)

The capacitor between SPFIL (pin 3) and SPCIN (pin 4)

- SANYO Semiconductor Co.,Ltd. assumes no responsibility for equipment failures that result from using products at values that exceed, even momentarily, rated values (such as maximum ratings, operating condition ranges, or other parameters) listed in products specifications of any and all SANYO Semiconductor Co.,Ltd. products described or contained herein.
- SANYO Semiconductor Co.,Ltd. strives to supply high-quality high-reliability products, however, any and all semiconductor products fail or malfunction with some probability. It is possible that these probabilistic failures or malfunction could give rise to accidents or events that could endanger human lives, trouble that could give rise to smoke or fire, or accidents that could cause damage to other property. When designing equipment, adopt safety measures so that these kinds of accidents or events cannot occur. Such measures include but are not limited to protective circuits and error prevention circuits for safe design, redundant design, and structural design.
- In the event that any or all SANYO Semiconductor Co.,Ltd. products described or contained herein are controlled under any of applicable local export control laws and regulations, such products may require the export license from the authorities concerned in accordance with the above law.
- No part of this publication may be reproduced or transmitted in any form or by any means, electronic or mechanical, including photocopying and recording, or any information storage or retrieval system, or otherwise, without the prior written consent of SANYO Semiconductor Co.,Ltd.
- Any and all information described or contained herein are subject to change without notice due to product/technology improvement, etc. When designing equipment, refer to the "Delivery Specification" for the SANYO Semiconductor Co.,Ltd. product that you intend to use.
- Information (including circuit diagrams and circuit parameters) herein is for example only; it is not guaranteed for volume production.
- Upon using the technical information or products described herein, neither warranty nor license shall be granted with regard to intellectual property rights or any other rights of SANYO Semiconductor Co.,Ltd. or any third party. SANYO Semiconductor Co.,Ltd. shall not be liable for any claim or suits with regard to a third party's intellectual property rights which has resulted from the use of the technical information and products mentioned above.

This catalog provides information as of June, 2007. Specifications and information herein are subject to change without notice.