



Preliminary

3.3V LVPECL 1:2 Clock Fanout Buffer AK8181C

Features

- Two differential 3.3V LVPECL outputs
- Selectable two LVTTTL/LVCMOS inputs
- Clock output frequency up to 266MHz
- Output skew : 20ps maximum
- Part-to-part skew : 200ps maximum
- Propagation delay : 1.4ns maximum
- Additive phase jitter(RMS) : 0.03ps(typical)
- Operating Temperature Range: -40 to +85°C
- Package: 14-pin TSSOP (Pb free)
- Pin compatible with ICS8535I-21

Description

The AK8181C is a member of AKM's LVPECL clock fanout buffer family designed for telecom, networking and computer applications, requiring a range of clocks with high performance and low skew. The AK8181C distributes 2 buffered clocks.

AK8181C are derived from AKM's long-term-experienced clock device technology, and enable clock output to perform low skew. The AK8181C is available in a 14-pin TSSOP package.

Block Diagram

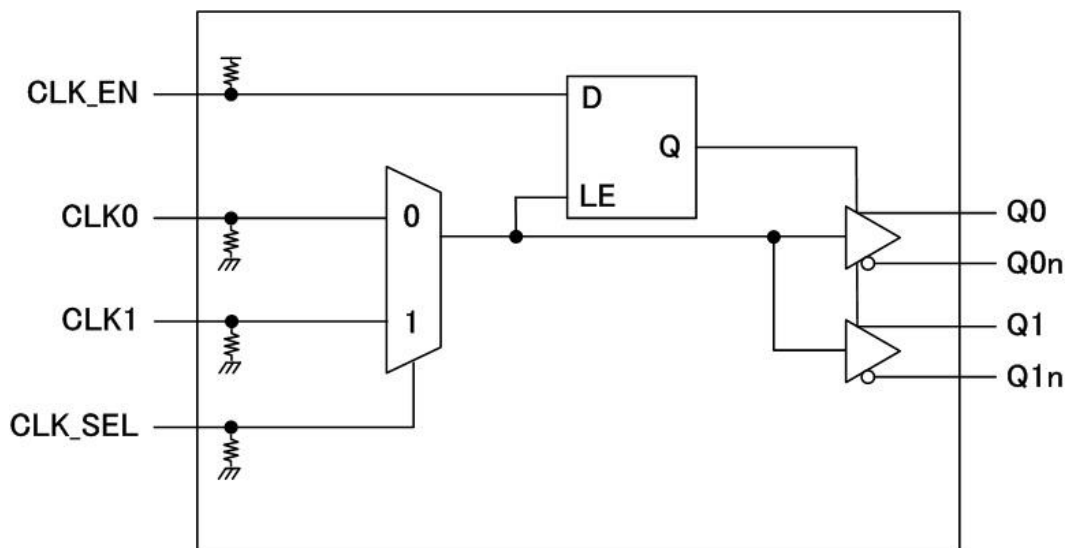

Pin Descriptions

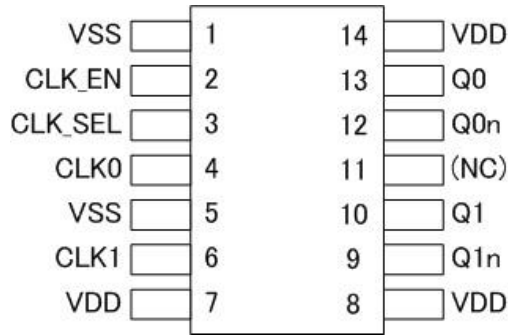

Package: 14-Pin TSSOP(Top View)

Pin No.	Pin Name	Pin Type	Pullup down	Description
1	VSS	PWR	---	Negative power supply
2	CLK_EN	IN	Pull up	Synchronizing clock output enable (LVCMOS/LVTTL) Pin is connected to VDD by internal resistor. (typ. 51kΩ) High (Open): clock outputs follow clock input. Low: Q outputs are forced low, Qn outputs are forced high.
3	CLK_SEL	IN	Pull down	CLK Select Input (LVCMOS/LVTTL) Pin is connected to VSS by internal resistor. (typ. 51kΩ) High: selects CLK1 input Low (Open): selects CLK0 input
4	CLK0	IN	Pull down	LVCMOS/LVTTL Clock Input Pin is connected to VSS by internal resistor. (typ. 51kΩ) *When using CLK1 input (CLK_SEL=High),it should be connected to VSS or opened.
5	VSS	PWR	---	Negative power supply
6	CLK1	IN	Pull down	LVCMOS/LVTTL Clock Input Pin is connected to VSS by internal resistor. (typ. 51kΩ) *When using CLK0 input (CLK_SEL=Low), it should be connected to VSS or opened.
7	VDD	PWR	---	Positive power supply
8	VDD	PWR	---	Positive power supply
9,10	Q1n, Q1	OUT	---	Differential clock output (LVPECL)
11	NC	---	---	No connect
12, 13	Q0n, Q0	OUT	---	Differential clock output (LVPECL)
14	VDD	PWR	---	Positive power supply

PWR: Power pin, IN: Input pin, OUT: Output pin

Absolute Maximum Rating

Over operating free-air temperature range unless otherwise noted ⁽¹⁾

Items	Symbol	Ratings	Unit
Supply voltage ⁽²⁾	VDD	-0.3 to 4.6	V
Input voltage ⁽²⁾	V _{in}	-0.5 to VDD+0.5	V
Input current (any pins except supplies)	I _{IN}	±10	mA
Storage temperature	T _{stg}	-55 to 150	°C

Note

(1) Stress beyond those listed under “Absolute Maximum Ratings” may cause permanent damage to the device. These are stress ratings only. Functional operation of the device at these or any other conditions beyond those indicated under “Recommended Operating Conditions” is not implied. Exposure to absolute-maximum-rating conditions for extended periods may affect device reliability. Electrical parameters are guaranteed only over the recommended operating temperature range.

(2) VSS=0V



ESD Sensitive Device

This device is manufactured on a CMOS process, therefore, generically susceptible to damage by excessive static voltage. Failure to observe proper handling and installation procedures can cause damage. AKM recommends that this device is handled with appropriate precautions.

Recommended Operation Conditions

Parameter	Symbol	Conditions	Min	Typ	Max	Unit
Operating temperature	T _a		-40		85	°C
Supply voltage ⁽¹⁾	VDD	VDD±5%, VSS=0V	3.135	3.3	3.465	V

(1) Power of 3.3V requires to be supplied from a single source. A decoupling capacitor of 0.1μF for power supply line should be located close to each VDD pin.

Pin Characteristics

Parameter	Symbol	Conditions	Min	Typ	Max	Unit
Input Capacitance	C _{IN}			4		pF
Input Pullup Resistor	R _{PU}			51		kΩ
Input Pulldown Resistor	R _{PD}			51		kΩ

DC Characteristics

All specifications at VDD= 3.3V±5%, VSS=0V, Ta: -40 to +85°C, unless otherwise noted

Parameter		Symbol	Conditions	MIN	TYP	MAX	Unit
Input High Voltage		V _{IH}		2.0		VDD+0.3	V
Input Low Voltage	CLK0, CLK1	V _{IL}		-0.3		1.3	V
	CLK_EN, CLK_SEL			-0.3		0.8	V
Input High Current	CLK0, CLK1, CLK_SEL	I _H	Vin=VDD=3.465V			150	μA
	CLK_EN		Vin=VDD=3.465V			5	μA
Input Low Current	CLK0, CLK1, CLK_SEL	I _L	Vin=VSS, VDD=3.465V	-5			μA
	CLK_EN		Vin=VSS, VDD=3.465V	-150			μA
Output High Voltage ⁽¹⁾		V _{OH}		VDD-1.4		VDD-0.9	V
Output Low Voltage ⁽¹⁾		V _{OL}		VDD-2.0		VDD-1.7	V
Peak-to-Peak Output Voltage Swing		V _{SWING}		0.6		1.0	V
Supply Current		I _{DD}				50	mA

(1) Outputs terminated with 50Ω to VDD-2V.

AC Characteristics

All specifications at VDD= 3.3V±5%, VSS=0V, Ta: -40 to +85°C, unless otherwise noted

Parameter	Symbol	Conditions	MIN	TYP	MAX	Unit
Output Frequency	f _{OUT}				266	MHz
Propagation Delay ⁽¹⁾	t _{PD}		0.6		1.4	ns
Output Skew ⁽²⁾⁽³⁾	t _{sk(O)}				20	ps
Part-to-Part Skew ⁽³⁾⁽⁵⁾	t _{skPP}				200	ps
Buffer Additive Jitter, RMS	t _{jit}	12kHz to 20MHz@156.25MHz		0.03		ps
Output Rise/Fall Time ⁽⁴⁾	t _r , t _f	20% to 80%	200		600	ps
Output Duty Cycle	DC _{OUT}		48	50	52	%

(1) Measured from the VDD/2 of the input to the differential output crossing point.

(2) Defined as skew between outputs at the same supply voltage and with equal load conditions.

(3) This parameter is defined in accordance with JEDEC Standard 65.

(4) Design value.

(5) Defined as skew between outputs on different devices operating at the same supply voltages and with equal load conditions. Using the same type of inputs on each device, the outputs are measured at the differential cross points.

Parameter Measurement Information

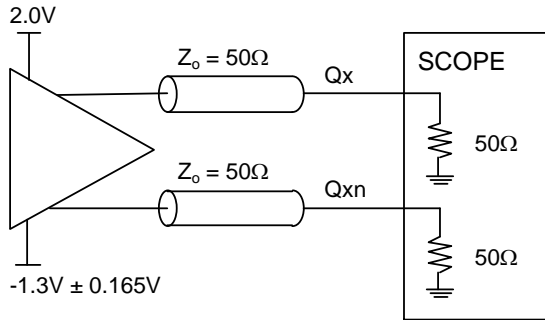

Figure 1 3.3V Output Load Test Circuit

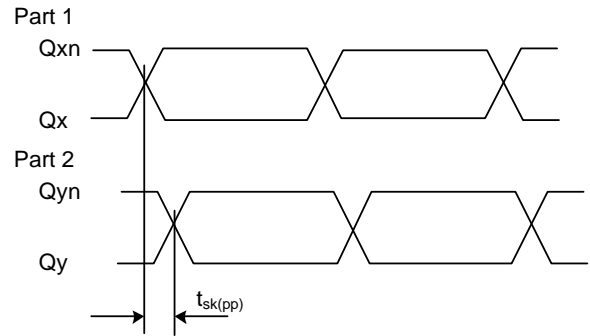

Figure 2 Part-to-Part Skew

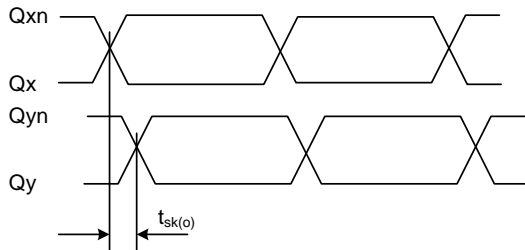

Figure 3 Output Skew

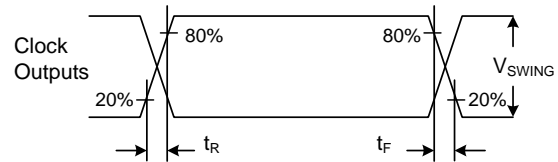

Figure 4 Output Rise/Fall Time

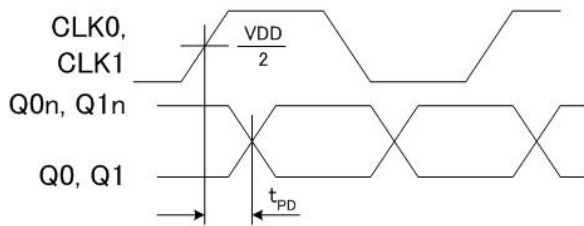

Figure 5 Propagation Delay

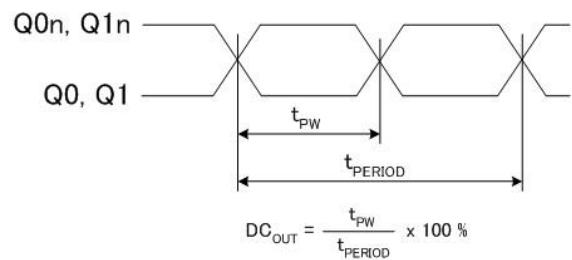

Figure 6 Output Duty/ Pulse Width/ Period

Function Table

The following table shows the inputs/outputs clock state configured through the control pins.

Table 1: Control Input Function Table

Inputs			Outputs	
CLK_EN	CLK_SEL	Selected Source	Q0, Q1	Q0n, Q1n
0	0 (Open)	CLK0	Disabled: Low	Disabled: High
0	1	CLK1	Disabled: Low	Disabled: High
1 (Open)	0 (Open)	CLK0	Enabled	Enabled
1 (Open)	1	CLK1	Enabled	Enabled

After CLK_EN switches, the clock outputs are disabled or enabled following a rising and falling input clock edge as shown in Figure 7. In the active mode, the state of the outputs are a function of the CLK0 and CLK1 inputs as described in Table 2.

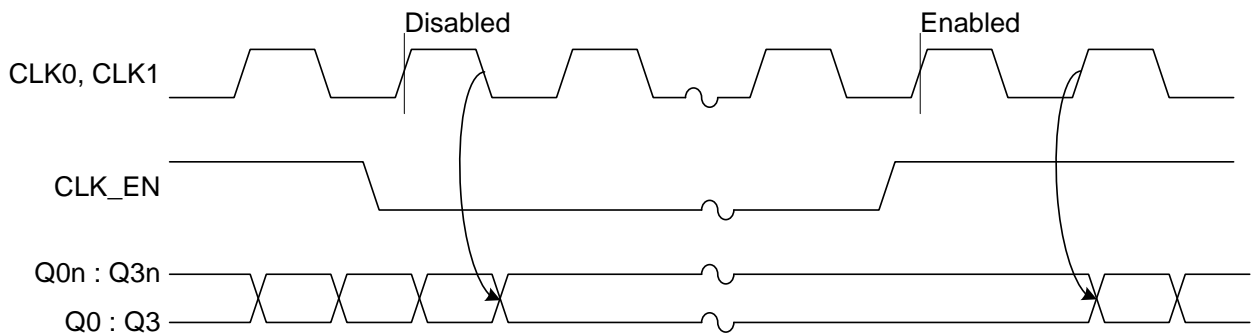

Figure 7 CLK_EN Timing Diagram

Table 2 Clock Input Function Table

Inputs	Outputs	
CLK0 or CLK1	Q0, Q1	Q0n, Q1n
0	Low	High
1	High	Low

Package Information

- Mechanical data : 14pin TSSOP

Preliminary

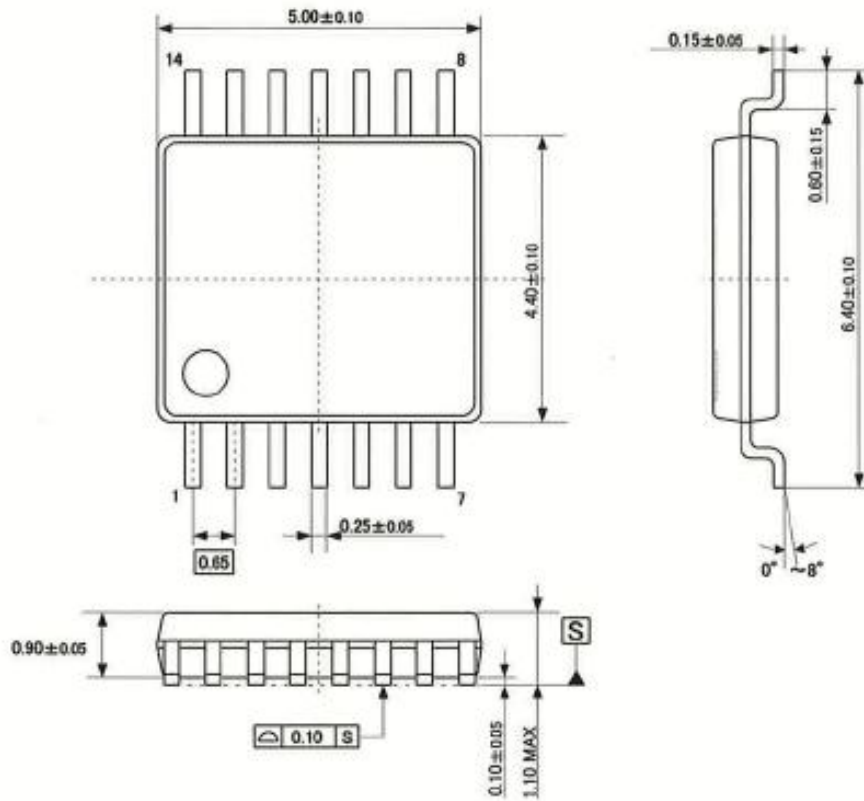

- Marking

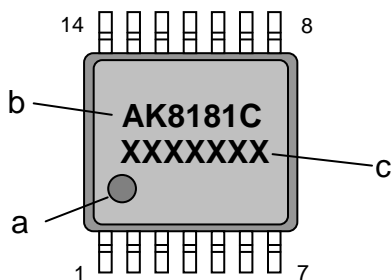

- a: #1 Pin Index
- b: Part number
- c: Date code (7 digits)

- RoHS Compliance

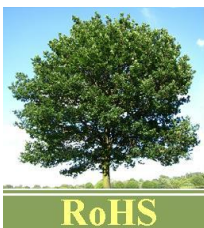

All integrated circuits from Asahi Kasei Microdevices Corporation (AKM) assembled in “lead-free” packages* are fully compliant with RoHS.

(*) RoHS compliant products from AKM are identified with “Pb free” letter indication on product label posted on the anti-shield bag and boxes.

IMPORTANT NOTICE

- These products and their specifications are subject to change without notice.
When you consider any use or application of these products, please make inquiries the sales office of Asahi Kasei Microdevices Corporation (AKM) or authorized distributors as to current status of the products.
- Descriptions of external circuits, application circuits, software and other related information contained in this document are provided only to illustrate the operation and application examples of the semiconductor products. You are fully responsible for the incorporation of these external circuits, application circuits, software and other related information in the design of your equipments. AKM assumes no responsibility for any losses incurred by you or third parties arising from the use of these information herein. AKM assumes no liability for infringement of any patent, intellectual property, or other rights in the application or use of such information contained herein.
- Any export of these products, or devices or systems containing them, may require an export license or other official approval under the law and regulations of the country of export pertaining to customs and tariffs, currency exchange, or strategic materials.
- AKM products are neither intended nor authorized for use as critical components^{Note1)} in any safety, life support, or other hazard related device or system^{Note2)}, and AKM assumes no responsibility for such use, except for the use approved with the express written consent by Representative Director of AKM. As used here:
 - Note1) A critical component is one whose failure to function or perform may reasonably be expected to result, whether directly or indirectly, in the loss of the safety or effectiveness of the device or system containing it, and which must therefore meet very high standards of performance and reliability.
 - Note2) A hazard related device or system is one designed or intended for life support or maintenance of safety or for applications in medicine, aerospace, nuclear energy, or other fields, in which its failure to function or perform may reasonably be expected to result in loss of life or in significant injury or damage to person or property.
- It is the responsibility of the buyer or distributor of AKM products, who distributes, disposes of, or otherwise places the product with a third party, to notify such third party in advance of the above content and conditions, and the buyer or distributor agrees to assume any and all responsibility and liability for and hold AKM harmless from any and all claims arising from the use of said product in the absence of such notification.