

Programmable Switch-mode, USB/AC Input Li+ Battery Charger with TurboCharge™ Mode*

FEATURES & APPLICATIONS

- Programmable USB/AC Li-Ion battery charger
- TurboCharge™ Mode: 750mA output from 500mA USB
- High-efficiency current-mode PWM controller
 - 750kHz to 1.25MHz switching frequency
 - 0% to 100% duty-cycle
- 4.35 to 6.5V input voltage range
- Small 1.3 x 2.1 uCSP™-15 package (0.4mm pitch)
- High-accuracy output voltage regulation: 1%
- Low reverse leakage current
- Digital programming of all major parameters via I²C interface (with several addresses) and non-volatile memory
 - Battery voltage set point
 - Pre-charge, fast charge, termination current
 - Fast charge voltage threshold
 - Temperature limits
 - Automatic restart threshold
- Status/Fault indicator
- Stability with ceramic capacitors
- Wide range of protection features
 - Thermal monitor
 - Safety timers
 - Current limit
 - Input/output over-voltage lockout

Applications

- GSM Handsets
- UMTS Handsets
- Portable Media & Gaming Players
- Digital camcorders/still cameras
- Handheld GPS/PDAs

INTRODUCTION

The SMB135 is a programmable single-cell lithium-ion/lithium-polymer battery charger for a variety of portable applications. The device provides a simple and efficient way to charge high-capacity Li-Ion batteries via a USB port or an AC adapter. Unlike conventional devices, the SMB135's high-efficiency operation eliminates large internal temperature rise and localized hot spot in handheld equipment. Summit's proprietary TurboCharge™ mode allows a 750mA charge current from a 500mA USB port, resulting to significantly reduced charge times.

Charge control includes qualification, trickle-charge, pre-charge, constant current/constant voltage, and termination/safety settings that are fully programmable via a serial I²C/SMBus making the device truly a flexible solution. Fast charge current level (one or five unit loads) can be set via I²C or an input pin (USB500/100). An Enable (EN) pin is also provided for suspending USB charging and allowing the device to work in parallel with AC charger, which may already be integrated into a PMIC device. In this case, the SMB135 does not allow current to flow back to the USB port.

The SMB135 offers a wide variety of features that protect the battery pack as well as the charger and input circuitry: over-current, under/over-voltage and thermal protection. Ultra-precise, 1% accurate, Kelvin-sensed ADOC™ technology allows accurate control of battery float voltage and improves battery capacity utilization. Status can be monitored via the serial port for charge state and fault conditions. In addition, one LED driver output can be used to signal charge status or an under-/over-voltage condition. As a protection mechanism, when the junction temperature approaches approximately 110°C, the PWM switcher will start to cut back on the duty cycle, to reduce current.

The SMB135 is available in a space-saving 1.3mm x 2.1mm uCSP™ package with lead-free balls as well as in a lead-free 5x5 QFN-32 package, and is rated over the -30°C to +85°C temperature range.

SIMPLIFIED APPLICATIONS DRAWING

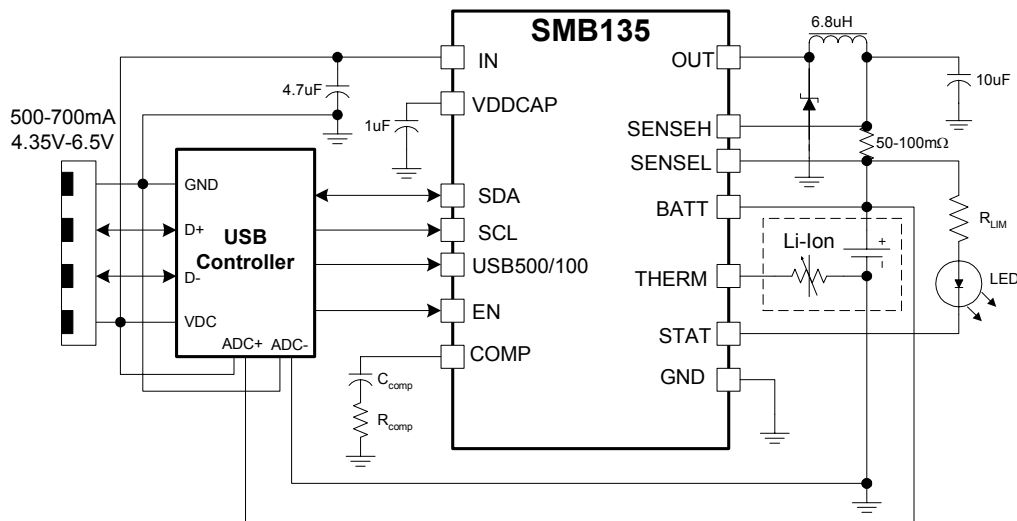

Figure 1 – Applications block diagram featuring the SMB135 programmable switch-mode battery charger.

* Patent Pending



GENERAL DESCRIPTION

The SMB135 is a fully programmable battery charger for single-cell Li-Ion and Li-Polymer battery packs. The device's high-efficiency, switch-mode operation reduces heat dissipation and allows for higher current capability for a given package size. The SMB135 provides four main charging phases: trickle-charge, pre-conditioning (pre-charge), constant current and constant voltage. The overall system accuracy of the SMB135 is 1%, allowing for a higher capacity utilization versus other conventional solutions.

When a battery or an external supply is inserted and the EN (ENABLE) input is asserted, the SMB135 performs the pre-qualification checks before initiating a charging cycle. The input voltage needs to be higher than the UVLO threshold and the cell temperature needs to be within the temperature limits for the charging cycle to start. As soon as the input supply is removed, the SMB135 enters a shutdown mode, thereby saving battery power. A programmable option also exists that allows the user to prevent battery charging until an I²C command has been issued.

If the battery voltage is below 2.0V (trickle-charge to pre-charge threshold), the device will apply a trickle-charge current of 10mA (typical). This allows the SMB135 to reset the protection circuit in the battery pack and bring the battery voltage to a higher level without compromising safety.

Once the battery voltage crosses the 2.0V threshold, the SMB135 enters the pre-charge mode. This mode replenishes deeply depleted cells and minimizes heat dissipation during the initial charge cycle. The preconditioning current is programmable, with the default value at C/10. If the battery voltage does not reach the preconditioning voltage level (programmable) within a specified amount of time (pre-charge timeout), the safety timer expires and the charge cycle is terminated.

When the battery voltage reaches the pre-charge to fast-charge voltage level, the SMB135 enters the constant current (fast charge) mode. The fast charge current level is programmable in two ways: a) via an external sense resistor and b) via the corresponding register.

Once the final float voltage (programmable) has been reached, the battery charger will enter a constant voltage mode in which the battery voltage is kept constant, allowing the charge current to gradually taper off. The constant-voltage charging mode will continue until the charge current drops below the termination current threshold, or until the fast charge timer has expired. The termination current threshold is programmable from 25mA to 130mA in 15mA increments.

After the charge cycle has terminated, the SMB135 continues to monitor the battery voltage. If the battery voltage falls below the recharge threshold (typically 115mV below float voltage), the SMB135 can automatically top-off the battery.

A wide range of protection features is also included in the SMB135. These include input and output over-voltage protection, battery missing detector and thermal monitor for continuous cell temperature monitoring and pre-qualification.

The following charging parameters can be adjusted dynamically via the I2C interface, for optimizing battery management real-time. These parameters can also be programmed statically via a user-friendly GUI interface:

- Battery (float) voltage
- Fast charge current
- Pre-conditioning voltage threshold
- Pre-conditioning charge current
- Termination current
- Safety charge timers
- Temperature window

The SMB135 also offers three programmable PWM switching frequencies ranging from 750kHz to 1250kHz in 250kHz increments.



INTERNAL BLOCK DIAGRAM

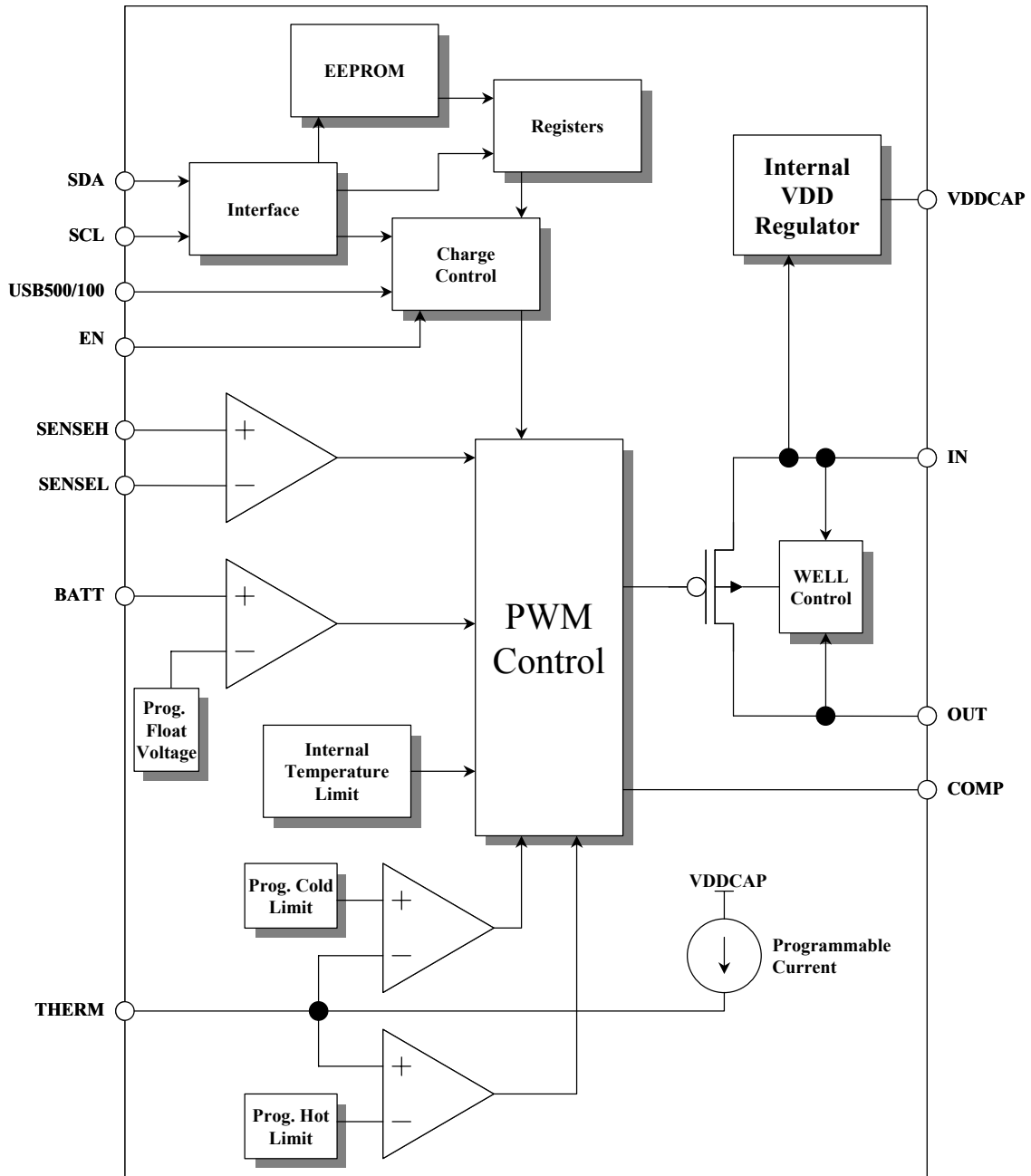

Figure 2 – Internal block diagram of the SMB135 programmable switch-mode battery charger.

**PACKAGE AND PIN DESCRIPTIONS**

Ball Number (CSP-15)	Pin Number (QFN-32)	Pin Name	Pin Type	Pin Description
A1	1	BATT	I	Battery Voltage Sense – Connect directly to positive terminal of battery.
B1	4	SENSEH	I	Charge Current Sense – Connect to high-side of charge current sense resistor.
C1	5	SENSEL	I	Charge Current Sense – Connect to low-side of charge current sense resistor (allows for higher accuracy).
D1	7	COMP	I	Primary Compensation – Connect to R/C compensation network.
E1	10	STAT	O	Status and Fault Indicator.
A2	29	THERM	I/O	Battery Thermistor Sense.
B2	27	VDDCAP	PWR	VDD Bypass – Connect to VDD bypass capacitor with 1 μ F or greater capacitor.
C2	3, 8, 18, 20, 22, 30, 32	AGND	PWR	Analog Ground – Connect to isolated PCB ground.
D2	3, 8, 18, 20, 22, 30, 32	GND	PWR	Ground – Connect to isolated PCB ground.
E2	12	IN	I	USB (+4.35V to +5.5V) or Adaptor Input (+4.35V to +6.5V) – Bypass with a 1 μ F or greater capacitor.
A3	25	EN	I	Enable Input (active low) – A logic low signal on this pin powers-up the device and allows a battery charge cycle to occur. A logic high signal on this pin forces IN to a high-impedance, low-current state, and the internal VDD regulator is powered down. If unused, this pin should be tied to GND.
B3	24	USB500/100	I	Charge Current Regulation Setting – Connect to logic high for 500mA or low for 100mA charge current setting. This charging current can be overridden by I ² C but only for values less than 500mA and 100mA respectively. The actual charging values are (500-I _{OFFSET}) mA and (100-I _{OFFSET}) mA respectively, with I _{OFFSET} being the device's total active current (Note 1). When unused, this pin should be tied to VDDCAP or GND (do not leave floating).
C3	21	SDA	I/O	I ² C Bus Data.
D3	19	SCL	I	I ² C Bus Clock.
E3	14	OUT	O	Charge Current Output – Connect to inductor.
N/A	33	GND	PWR	Exposed metal (thermal) Pad on bottom of SMB135. The thermal pad of the SMB135 package must be connected to the PCB GND.
N/A	2, 6, 9, 11, 13, 15, 16, 17, 23, 26, 28, 31	NC	N/A	



ABSOLUTE MAXIMUM RATINGS

Temperature Under Bias -55°C to 155°C
 Storage Temperature..... -55°C to 125°C
 Terminal Voltage with Respect to GND:
 VIN -0.3V to +10V
 All Others -0.3V to +6V
 Output Short Circuit Current 100mA
 Lead Solder Temperature (10 s)..... 300°C
 Junction Temperature..... 150°C
 HBM ESD Rating per JEDEC.....4000V
 MM ESD Rating per JEDEC.....200V
 CDM ESD Rating per JEDEC.....1000V
 Latch-Up testing per JEDEC.....±100mA

RECOMMENDED OPERATING CONDITIONS

Industrial Temperature Range -30°C to +85°C
 VIN+4.35V to +6.5V
 Package Thermal Resistance (θ_{JA})
 uCSP™-15.....55°C/W
 5x5 QFN-32 (thermal pad connected to PCB).37.2°C/W

RELIABILITY CHARACTERISTICS

Data Retention.....100 Years
 Endurance.....100,000 Cycles

Note – The device is not guaranteed to function outside its operating rating. Stresses listed under Absolute Maximum Ratings may cause permanent damage to the device. These are stress ratings only and functional operation of the device at these or any other conditions outside those listed in the operational sections of the specification is not implied. Exposure to any absolute maximum rating for extended periods may affect device performance and reliability. Devices are ESD sensitive. Handling precautions are recommended.

DC OPERATING CHARACTERISTICS

$T_A = -30^\circ\text{C}$ to $+85^\circ\text{C}$, $V_{IN} = +5.0\text{V}$, $V_{FLOAT} = +4.2\text{V}$ unless otherwise noted. All voltages are relative to GND.

Symbol	Parameter	Conditions	Min	Typ	Max	Unit
General						
V_{IN}	Input supply voltage	$V_{FLT} = 4.2\text{V}$, $I_{CHG}=100\text{mA}$	+4.35		+6.5	V
V_{UVLO}	Under-voltage lockout voltage	$V_{FLT} = 4.2\text{V}$		+3.5		V
$V_{UVLO-HYS}$	Under-voltage lockout hysteresis	$V_{FLT} = 4.2\text{V}$		10		mV
V_{OVLO}	Input over-voltage lockout voltage			+7.0		V
V_{BOV}	Battery over-voltage lockout voltage			$V_{FLT}+0.1$		V
V_{ASHDN}	Automatic shutdown threshold voltage	$V_{IN} - V_{BATT}$		130		mV
$I_{DD-ACTIVE}$	Active supply current	PWM not switching		0.8	4	mA
I_{OFFSET}	Active supply current	PWM switching		5		mA
$I_{DD-SHDN}$	Shutdown supply current	Input voltage present		7	20	μA
I_{LK}	Reverse leakage current	$V_{IN} < V_{BATT}$ (no adapter), $T=0^\circ\text{C}$ to $+70^\circ\text{C}$			2	μA
T_{REG}	Thermal regulation temperature			110		°C



DC OPERATING CHARACTERISTICS (CONTINUED)

T_A = -30°C to +85°C, V_{IN} = +5.0V, V_{FLOAT} = +4.2V unless otherwise noted. All voltages are relative to GND.

Symbol	Parameter	Conditions	Min	Typ	Max	Unit
Switch-mode Controller						
R _{RDSON}	FET On-resistance	V _{IN} = 5.0V		550		mΩ
I _{LIMIT}	Current limit	f _{OSC} =1.25MHz, V _{BATT} =3.0V		1000		mA
D.C.	Duty cycle	Maximum		100		%
		Minimum		0		%
Logic Inputs/Output						
V _{IL}	Input low level	All inputs except EN			600	mV
V _{IH}	Input high level	All inputs except EN	1.4			V
V _{ILEN}	Input low level				400	mV
V _{IHEN}	Input high level		1.2			V
V _{OL}	SDA/STAT Output low level	I _{SINK} =3mA			300	mV
I _{BIAS}	Input bias current				1	μA
I _{SINK}	STAT sink current			5		mA
Battery Charger						
V _{SENSE}	Constant current sense voltage	Fast-charge mode, maximum voltage across sense resistor		52.5		mV
V _{TRICKLECHG}	Trickle-charge to pre-charge voltage threshold			2.0		V
I _{TRICKLECHG}	Trickle-charge current			10		mA
V _{PRECHG}	Pre-charge to fast-charge voltage threshold	100mV steps	2.400		3.100	V
I _{PRECHG}	Nominal pre-charge current	12.5mA steps, R _{SENSE} = 0.1Ω	25		212.5	mA
ΔI _{PRECHG}	Pre-charge current tolerance	I _{PRECHG} = 100mA, R _{SENSE} = 0.1Ω, T=0°C to +70°C	75	100	125	mA
I _{FCHG}	Nominal Fast charge current	16 steps, R _{SENSE} = 0.1Ω	47.5		525	mA
I _{CHG}	Nominal charge current	USB500/100=VIN, Note 1	495	525	555	mA
		USB500/100=GND, Note 1	75	100	125	mA
ΔI _{CHG}	Fast charge current tolerance	I _{FCHG} = 525mA, R _{SENSE} = 0.1Ω, T=0°C to +70°C	495	525	555	mA
V _{FLT}	Float voltage range	20mV steps	4.020		4.620	V
ΔV _{FLT}	Float voltage tolerance	T=+10°C to +50°C, V _{FLT} = 4.2V	-1		+1	%
I _{TERM}	Charge termination current	15mA steps, R _{SENSE} = 0.1Ω	25		130	mA
ΔI _{TERM}	Termination current tolerance	I _{TERM} = 55mA, R _{SENSE} = 0.1Ω, T=0°C to +70°C	25		85	mA

Note 1: The ACTUAL charging current always equals the nominal values given in the register tables minus I_{OFFSET}, where I_{OFFSET} is the device's total active current. The 525mA nominal value shown here is with the hex value F in register h00[7:4]. For USB1, the nominal value is the lower of the one selected in the register and 100mA.

Note 2: Voltage, current and frequency accuracies are only guaranteed for factory-programmed settings. Changing any of these parameters from the values reflected in the customer specific CSIR code will result in inaccuracies exceeding those specified above.

Note 3: The SMB135 device is not intended to function as a battery pack protector. Battery packs used in conjunction with this device need to provide adequate internal protection and to comply with the corresponding battery pack specifications.



DC OPERATING CHARACTERISTICS (CONTINUED)

$T_A = -30^{\circ}\text{C}$ to $+85^{\circ}\text{C}$, $V_{IN} = +5.0\text{V}$, $V_{FLOAT} = +4.2\text{V}$ unless otherwise noted. All voltages are relative to GND.

Symbol	Parameter	Conditions	Min	Typ	Max	Unit
Battery Charger						
V_{RECH}	Recharge threshold voltage			115		mV
CMR	Common mode range	Current Sense Amplifier, Note 4	2		V_{BATT}	V
T_{HI}	Charge cutoff temp (high)	Adjustable, conditions per typical application	30		65	$^{\circ}\text{C}$
T_{LO}	Charge cutoff temp (low)	Adjustable, conditions per typical application	-20		15	$^{\circ}\text{C}$

Note 4: Guaranteed by Design.

AC OPERATING CHARACTERISTICS

$T_A = -30^{\circ}\text{C}$ to $+85^{\circ}\text{C}$, $V_{IN} = +5.0\text{V}$, $V_{FLOAT} = +4.2\text{V}$ unless otherwise noted. All voltages are relative to GND.

Symbol	Description	Conditions	Min	Typ	Max	Unit
Oscillator						
f_{OSC}	Frequency range	250kHz steps (3 settings)	750		1250	kHz
Δf_{OSC}	Frequency accuracy	$f_{OSC} = 1.25\text{MHz}$ (default), $T = 0^{\circ}\text{C}$ to $+70^{\circ}\text{C}$	1.125	1.250	1.375	MHz
t_{START}	Start-up time	Note 5		20		ms
t_{GLITCH}	Glitch filter	Disabled		0		msec
		Enabled		250		msec
$t_{HOLDOFF}$	Hold-off time	Short	0		1	msec
		Long		256		msec
t_{FCTO}	Fast-charge Timeout	$t_{FCTO} = 350\text{min}$	-15	t_{FCTO}	+15	%
		$t_{FCTO} = 699\text{min}$				
		$t_{FCTO} = 1398\text{min}$				
t_{PCTO}	Pre-charge Timeout	$t_{PCTO} = 44\text{min}$	-15	t_{PCTO}	+15	%
		$t_{PCTO} = 87\text{min}$				
		$t_{PCTO} = 175\text{min}$				

Note 5: This is the time it takes for the device to be ready for I2C communication or charging after power-up (including coming out of shutdown). When charging is enabled, actual charging begins after the hold-off timer has expired.



CHARGING ALGORITHM (500mA)

Charge Algorithm (CC-CV) vs. Time

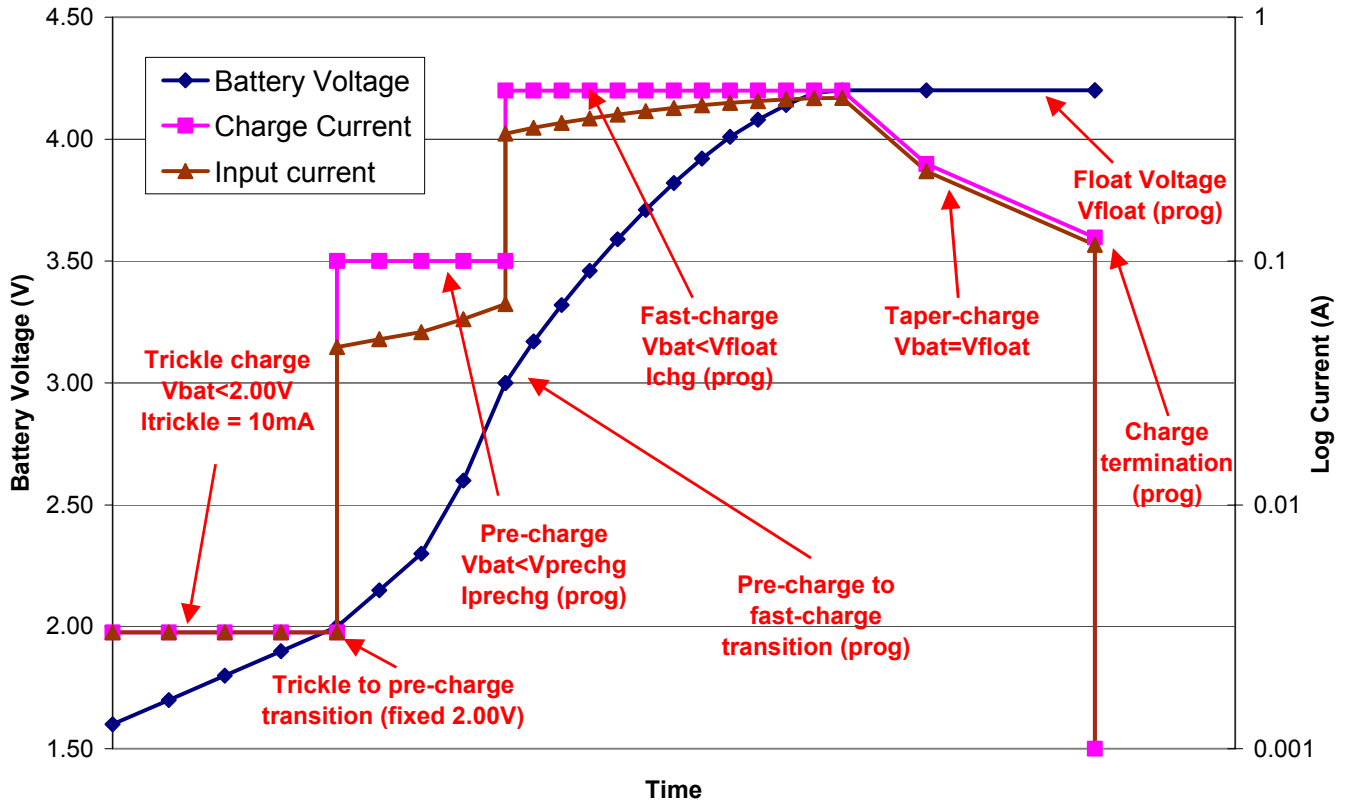

Figure 3 – Typical SMB135 Charging Algorithm



I²C-2 WIRE SERIAL INTERFACE AC OPERATING CHARACTERISTICS – 400 kHz

T_A = 0°C to +85°C, V_{IN} = +5.0V, V_{FLOAT} = +4.2V unless otherwise noted. All voltages are relative to GND.

Symbol	Description	Conditions	400kHz			
			Min	Typ	Max	Units
f _{SCL}	SCL clock frequency		0		400	kHz
T _{LOW}	Clock low period		1.3			μs
T _{HIGH}	Clock high period		0.6			μs
t _{BUF}	Bus free time between a STOP and a START condition	Before new transmission – Note 6	1.3			μs
t _{SU:STA}	Start condition setup time		0.6			μs
t _{HD:STA}	Start condition hold time		0.6			μs
t _{SU:STO}	Stop condition setup time		0.6			μs
t _{AA}	Clock edge to data valid	SCL low to valid SDA (cycle n)	0.2		0.9	μs
t _{DH}	Data output hold time	SCL low (cycle n+1) to SDA change	0.2			μs
t _R	SCL and SDA rise time	Note 6	20 + 0.1C _b		300	ns
t _F	SCL and SDA fall time	Note 6	20 + 0.1C _b		300	ns
t _{SU:DAT}	Data in setup time		100			ns
t _{HD:DAT}	Data in hold time		0		0.9	μs
TI	Noise filter SCL and SDA	Noise suppression		140		ns
t _{WR_CONFIG}	Write cycle time config	Configuration registers			10	ms
t _{WR_EE}	Write cycle time EE	Memory array			5	ms

Note 6: Guaranteed by Design.

I²C TIMING DIAGRAMS

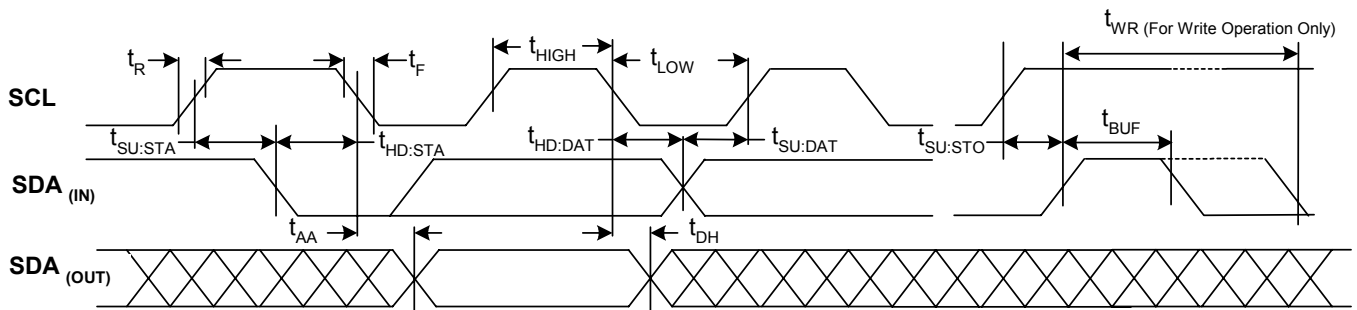
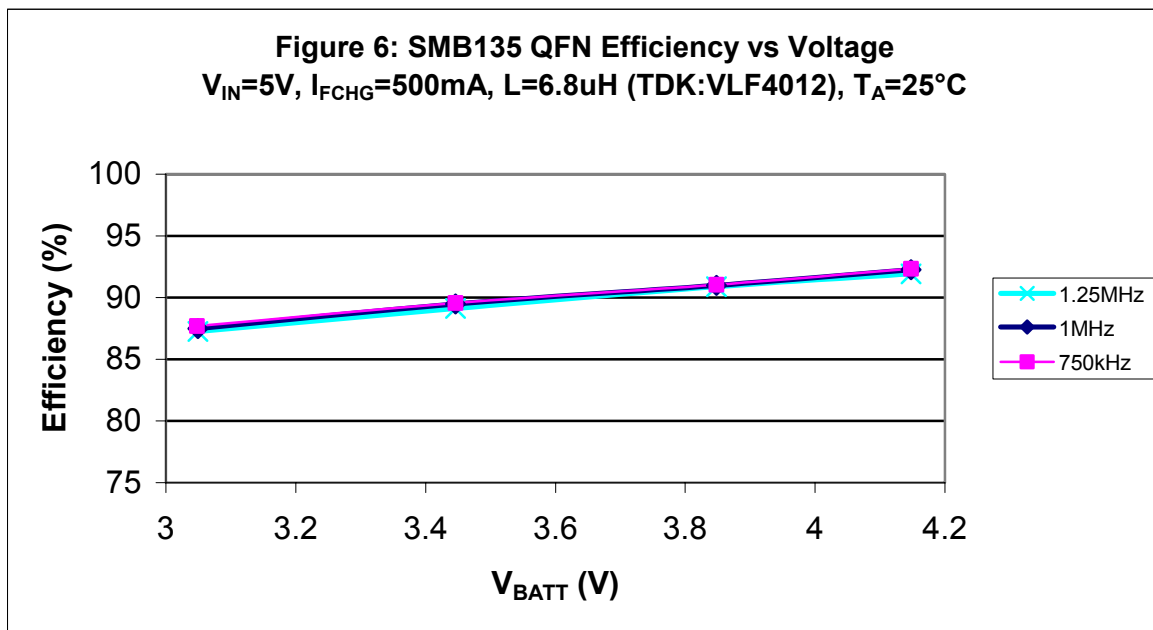
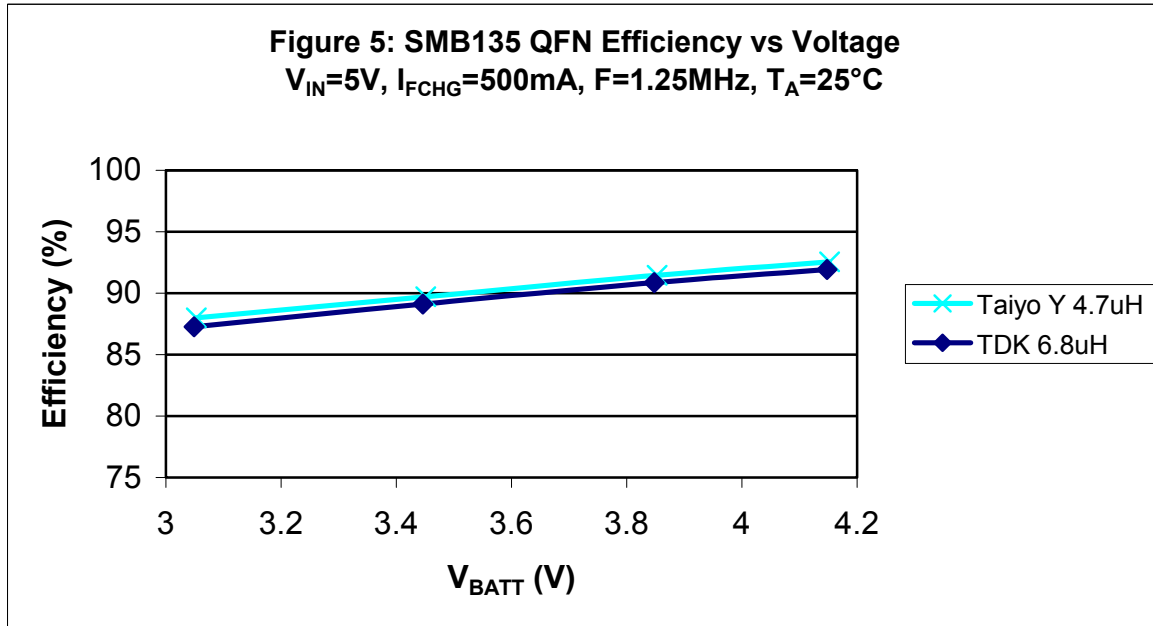

Figure 4 – I²C Timing Diagrams



EFFICIENCY GRAPHS





OUTPUT CURRENT GRAPH

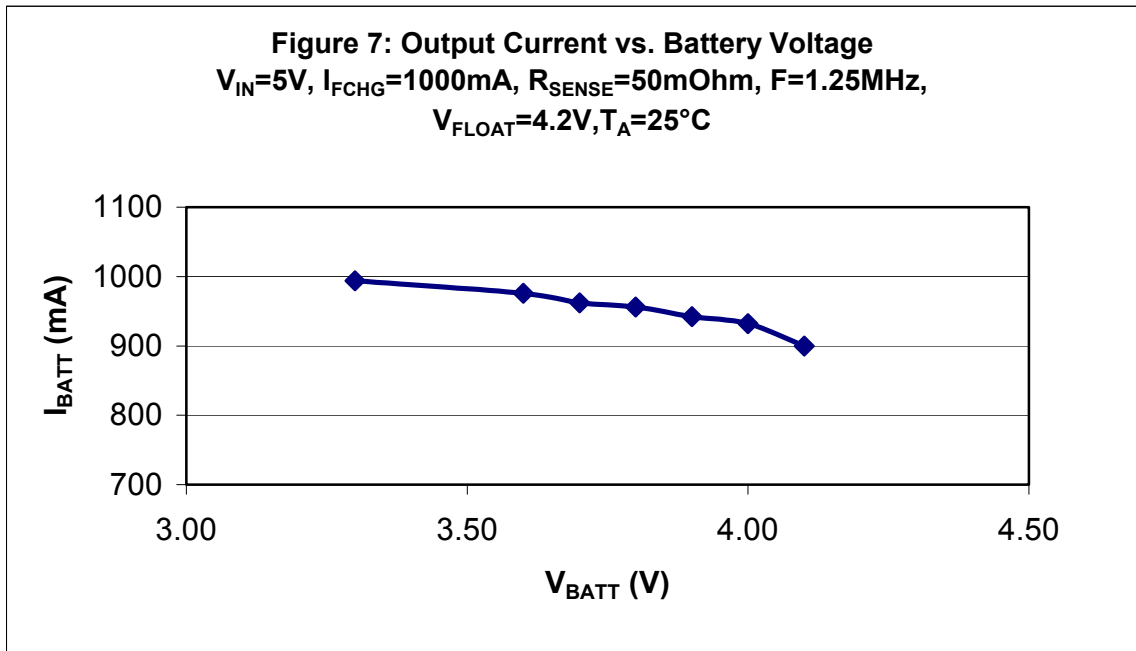



APPLICATIONS INFORMATION

DEVICE OPERATION

The SMB135 is a fully programmable battery charger for single-cell Li-Ion and Li-Polymer battery packs. The device's high-efficiency, switch-mode operation reduces heat dissipation and allows for higher current capability for a given package size. The SMB135 provides four main charging phases: trickle-charge, pre-conditioning (pre-charge), constant (fast-charge) current and constant voltage. The overall system accuracy of the SMB135 is 1%, allowing for a higher capacity utilization versus other conventional solutions. Furthermore, the main battery charging parameters are programmable, allowing for high design flexibility and sophisticated battery management.

Power Supply

The SMB135 can be powered from an input voltage between +4.35 and +6.5 Volts applied between the IN pin and ground. The voltage on the IN pin is monitored by Under-Voltage (UVLO) and Over-Voltage Lockout (OVLO) circuits, which prevent the charger from turning on when the voltage at this node is less than the UVLO threshold (+3.5V), or greater than the OVLO threshold (+7.0V). The IN pin also supplies an internal +2.5V VDD regulator, filtered by an external capacitor attached between the VDDCAP pin and ground; this filtered voltage is then used as an internal VDD supply. When the input supply is removed, the SMB135 enters a low-power shutdown mode, exhibiting a very low discharge leakage current (2 μ A), thereby extending battery life.

Pre-qualification Mode

When an external wall adaptor or a USB cable is connected, the SMB135 performs a series of pre-qualification tests before initiating the first charge cycle. The input voltage level needs to be higher than the UVLO threshold, lower than the OVLO threshold and 130mV greater than the battery voltage; the ENABLE input needs to be asserted or the appropriate I2C command needs to be asserted; and the cell temperature needs to be within the specified temperature limits for the charging cycle to start. The pre-qualification parameters are continuously monitored and charge cycle is suspended when one of them is outside the limits.

Trickle-charge Mode

Once all pre-qualification conditions are met, the device checks the battery voltage to decide if trickle-charging is required (Figure 3). If the battery voltage is below approximately 2.0V, a charging current of 10mA (typical) is applied on the battery cell. This allows the SMB135 to reset the protection circuit in the battery

pack and bring the battery voltage to a higher level without compromising safety.

Pre-charge Mode

Once the battery voltage crosses the 2.0V level, the SMB135 pre-charges the battery to safely charge the deeply discharged cells (Figure 3). The pre-charge (pre-conditioning) current is programmable from 25mA to 212.5mA in 12.5mA steps, assuming a sense resistor of 100m Ω (Register 00h). The SMB135 remains in this mode until the battery voltage reaches the pre-charge to fast-charge voltage threshold (programmable from +2.4V to +3.1V in 100mV steps). If the pre-charge to fast-charge voltage threshold is not exceeded before the pre-charge timer expires, the charge cycle is terminated and a corresponding timeout fault signal is asserted ("Pre-charge Timeout" in register 36h).

Constant Current Mode

When the battery voltage exceeds the pre-charge to fast-charge voltage threshold, the device enters the constant current (fast charge) mode. During this mode, the fast charge current level is set by either the USB500/100 input (see below) or the corresponding register. The fast charge current is programmable from 47.5mA to 525mA (16 steps), assuming a sense resistor of 100m Ω (Register 00h).

Constant Voltage Mode

When the battery voltage reaches the pre-defined float voltage, the fast-charge current starts diminishing. The float voltage is programmable from +4.00V to +4.62V in 20mV steps and is \pm 1% accurate over the 0 $^{\circ}$ C to +70 $^{\circ}$ C temperature range. The higher float voltage settings of the SMB135 enable the charging of modern battery packs with a required float voltage of 4.3V, 4.4V, and 4.5V. Furthermore, the ability to dynamically adjust the float voltage allows the implementation of sophisticated battery charging and control algorithms.

Charge Completion

The charge cycle is considered complete when the charge current reaches the programmed termination current threshold. The termination current is programmable from 25mA to 130mA in 15mA steps, assuming a sense resistor of 100m Ω (Register 01h). If the termination current threshold is not met before the fast-charge timer expires, the charge cycle is terminated and a corresponding timeout fault signal is asserted ("Fast-charge Timeout" in register 36h).



APPLICATIONS INFORMATION (CONTINUED)

EN (ENABLE)

EN is a logic input pin (active low) for enabling/disabling the device and/or restarting a charge cycle. When EN is held at a high logic level, IN goes into a high impedance state, the internal VDD regulator is powered down, no communication can occur over the I2C bus, and no charge cycles may proceed. EN must be held low in order to get any functionality out of the device. If unused, this pin should be tied to GND.

Charge Enable

The initiation of a charge cycle is controlled via the state of the volatile command register (Register 31, bit 4) and Register 0F bit 7. Bit 0F[7] controls the polarity of the command bit 31[4]; if 0F[7] is low, then a 0 at 31[4] will cause a charge cycle to start. Since the volatile register always powers-up to all 0's, then 0F[7] determines whether a charge cycle may begin on power up, or whether an I2C command must be issued to initiate charging.

USB500/100

USB500/100 is a logic input that allows the user to select a maximum fast charge current of 100mA or 500mA. When a logic high signal is applied on this pin, the charge current level may be as high as 500mA. When a logic low signal is applied on this input, the charge current level is limited to 100mA. In all cases, a lower register value setting will impose an overriding current limit. When the USB500/100 input is not used, this pin should be tied to VDDCAP or GND (do not leave floating). The USB500/100 functionality can also be controlled over the I2C interface (ignoring the state of the pin), allowing for full software control of charge current levels. This function is accomplished via register 31 bit 3, when Register 7 bit 0 is programmed high.

Automatic Battery Recharge

The SMB135 allows the battery to be automatically recharged (topped off) when the battery voltage falls by a value of V_{RECH} (115mV typical) below the programmed float voltage. Provided that the input power supply is still present, charging remains enabled and all the pre-qualification parameters are still met, a new charging cycle will be initiated. This ensures that the battery capacity remains high, without the need to manually re-start a charging cycle. The automatic battery recharging can be disabled if not required by the application (Register 03h).

Safety Timers

The integrated safety timers provide protection in case of a defective battery pack. The pre-charge timer starts after the pre-qualification check is completed and

resets when the transition to the constant current mode happens. At that point, the fast charge timer is initiated. The fast charge timer expires and charge cycle is terminated if the termination current level is not reached within the pre-determined duration. Each safety timer has three programmable timeout periods, which eliminates the need for external timing capacitors and allows for maximum design flexibility. In addition, each timer can be disabled by the appropriate bit selection in Register 05h.

Thermal Monitor

A temperature sensing I/O (THERM) is provided to prevent excessive battery temperatures during charging. The battery temperature is measured by sensing the voltage between the THERM pin and ground. The voltage is created by injecting a current into the parallel combination of Negative Temperature Coefficient (NTC) thermistor and a resistor. This voltage is then compared to two predetermined voltages representing the maximum and minimum temperature settings of the battery. The purpose of the resistor in parallel to the NTC thermistor is to linearize the resistance of the thermistor. The table below, shows the 1% resistor that should be placed in parallel with the corresponding thermistor.

If the temperature limits are exceeded, battery charging will be suspended until the temperature level has fallen within the safe operating range. The over-temperature limit is programmable from 30°C to 65°C, and the under-temperature limit is programmable from -20°C to 15°C, each in 5°C increments using Register 04h. In addition, the user can easily select the required bias current, based on the value of the negative temperature coefficient (NTC) thermistor located in the battery pack: 10k, 25k, 100k (Register 04h). Disabling the thermal monitor is also possible by selecting the appropriate bits in Register 04h.

As the temperature changes, the resistance of the thermistor changes creating a voltage proportional to temperature. The temperature coefficient or Beta (B) of the thermistor must be as close to 4400 as possible to achieve the maximum temperature accuracy.

NTC THERMISTOR	RESISTANCE
10K	24.9K
25K	61.9K
100K	249K

Table: NTC values and associated parallel resistances.

**APPLICATIONS INFORMATION (CONTINUED)****Frequency Selection**

The SMB135 can operate at three different switching frequencies (750kHz, 1MHz, 1.25MHz), which are selectable via an I²C command (Register 08h).

STAT Output

The STAT is an open-drain output that indicates battery charge status or an input under-voltage/over-voltage (UV/OV) condition. The type of indication can be selected via the corresponding bit in Register 07h. STAT has two modes of operation, as determined by Register 05h[7]: in Mode 0, STAT is asserted low whenever the battery is charging and de-asserted at all other times; in Mode 1, STAT is de-asserted when the charger is disabled, blinks during charging, and remains continuously asserted when the charge cycle has completed. A pull-up resistor should be applied on this pin for interfacing to a microcontroller or other logic IC.

Programmable Battery Charging

A unique feature of the SMB135 is the ability to modify all of the important charger parameters via internally programmable EEPROM, found in Registers 00-07. Once the device has been configured correctly, the EEPROM may be locked, preventing any further changes. Additionally, these registers may also be configured so that they may be updated in RAM (volatile), even if the underlying EEPROM is locked. This feature is useful if it is desired to actively manage the charging profile without making changes to the non-volatile defaults. Use Register 0E to control locking and volatile access. Before writing to Registers 00-07 in a volatile manner, Register 31[7] must first be set high.

FAULT and STATUS Indicators

A large number of battery charging conditions and parameters are monitored and corresponding fault and status indications are available to the user via the I²C compatible registers. These include the following:

- Charging status
- Safety timer timeout
- Over-temperature alarm
- Under-temperature alarm
- Over-voltage alarm
- Under-voltage alarm
- Missing battery detection

Glitch Filter

The SMB135 features a glitch filter to ensure that short violations in the UV or OV settings will not result in a fault-triggered action. The glitch filter is user-programmable (Register 05h) and may be set to 0msec (glitch filter disabled) or to 250msec. Enabling the glitch filter will delay “automatic recharge” and “current termination” by 250msec.

Hold-off Timer

The SMB135 features a hold-off timer that defines the amount of time from enabling the charger output until current begins flowing (trickle charge is excluded from this condition). Two choices (short & long) are available: <1msec or 256msec. The short timer is asynchronous and could be any value between 0msec and 1msec.

Internal Thermal Protection

When the die temperature of the SMB135 reaches approximately 110°C, the PWM switcher will cut back on the duty cycle to reduce current and prevent further die heating. This internal thermal protection circuit helps to improve device (and consequently, system) reliability.

**APPLICATIONS INFORMATION (CONTINUED)****EXTERNAL COMPONENTS (Figure 9)****Input and Output Capacitors**

The input capacitor needs to absorb all reflected input switching ripple current generated by the SMB135 device during charging, so that no ripple current will be seen on the input supply. The RMS value of input ripple current in buck type charger is given by,

$$I_{rms} = I_{bat} \frac{\sqrt{V_{bat} \cdot (V_{in} - V_{bat})}}{V_{in}}$$

A 4.7uF ceramic capacitor, X5R or X7R rated, with the 0603 size and low ESR sufficiently accommodates the above RMS current.

The output capacitor needs to ensure stability of the charger and low output ripple voltage. A 10uF ceramic capacitor, X5R or X7R rated, with the 0603 size and low ESR can make operations of the SMB135 device stable and absorb all AC portion of the inductor switching ripple current, since the RMS value of the output ripple current is much smaller than that of the input ripple current.

Inductor

The inductor in a buck type charger should be selected so that all its form-factor, cost, switching ripple and efficiency conform to the system requirement, or constitute the best compromise. Small dimensions, higher inductance value usually suggests higher DCR value. High DCR generates high conduction loss. Lower inductance value has less DCR but creates larger switching ripple current, which produces higher AC loss in the magnetic core and the windings. Setting the peak-to-peak ripple current approximately 30% of the maximum charge current is a commonly used method. Thus,

$$\Delta I_L = \frac{V_{in_{max}} - V_{bat}}{L} \cdot \frac{V_{bat}}{V_{in_{max}} \cdot fs}$$

and,

$$\Delta I_L = 30\% \cdot I_{bat_{max}}$$

where, L is inductance, fs is the switching frequency.

Diode

The rectifying diode circulates the inductor current when the internal top FET is turned off. This causes the forward voltage drop across the diode. Thus the diode power loss is,

$$P_{LOSS_DIODE} = V_{FD} \cdot I_{bat} \cdot \frac{V_{in} - V_{bat}}{V_{in}}$$

Minimize the diode power loss by choosing a low forward voltage diode. The reverse blocking voltage withstands any spike voltage that might appear across the diode. Be cautious of the reverse leakage current that constantly bleeds a small power out the battery cells when the battery cells aren't charged.

BOARD LAYOUT RECOMMENDATIONS

The SMB135 only requires an inductor, a rectifying diode, an input capacitor, an output capacitor, a sense resistor and some bypass components, the high side FET is internal (Figures 9, 10 and 11, Table 1). Place an input capacitor close to the IC. Place an inductor, a rectifying diode, and an output capacitor close to each other. Place a VDD cap, a COMP capacitor and a COMP resistor close to the pins. Pour sufficiently large copper shapes on both sides of the sense resistor, toward the output capacitor and toward the battery cells. Pour large copper shapes on the "IN", "OUT" and "GND" nodes as well. If it is necessary to route from these nodes to the other side of the board, place enough number of vias. Accuracy of current measurements and therefore accuracy of charge current control are at maximum only if both the SENSEH trace and the SENSEL trace are directly connected to each side of the resistor pads without contacting any shapes on their ways. Make the two routes a differential pair if possible. Internal ground planes and power planes quickly sink heat generated by the SMB135, the rectifying diode, and the inductor, furthermore reduce noise concern for the IC by providing shielding.



APPLICATIONS INFORMATION (CONTINUED)

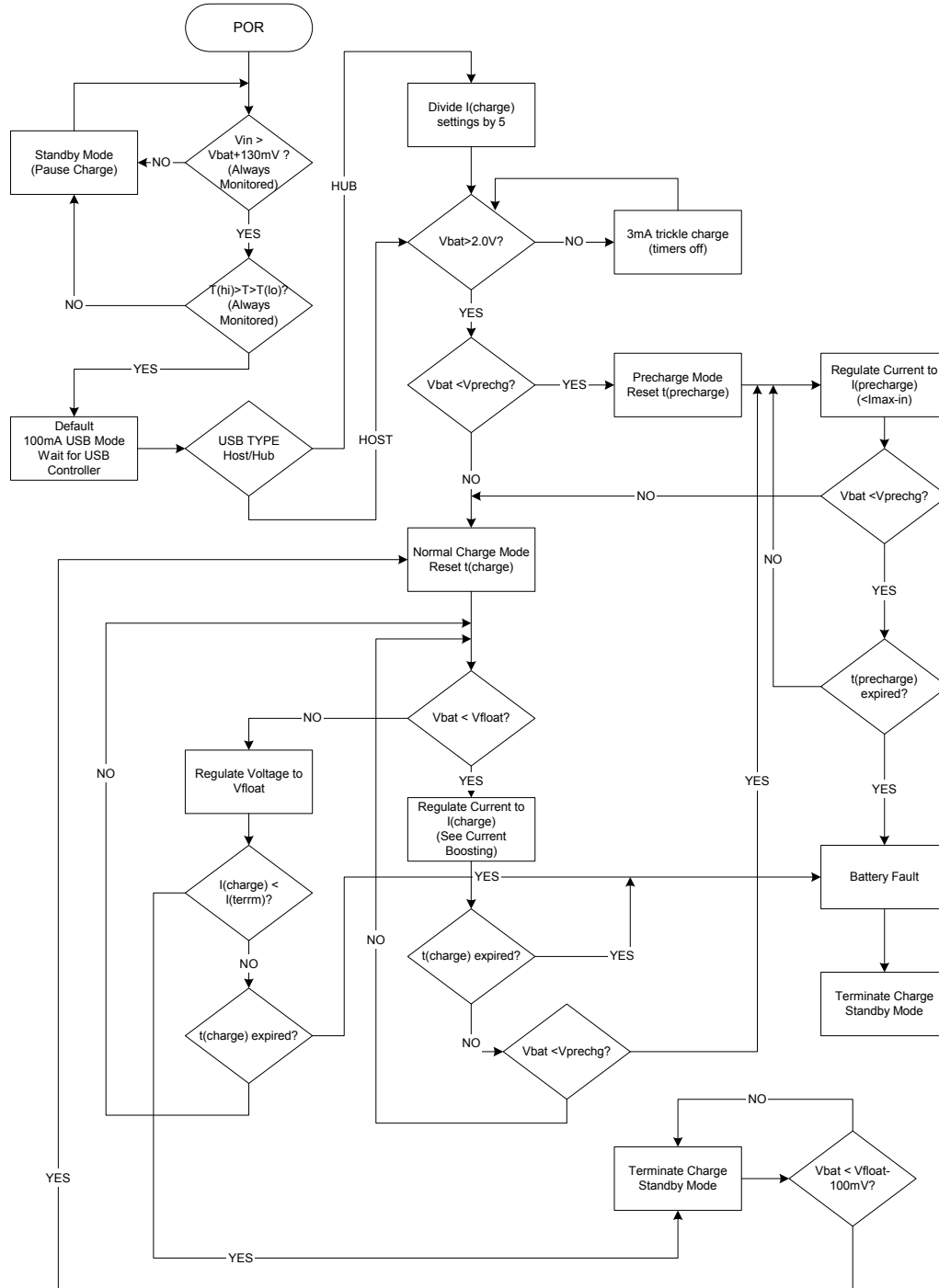

Figure 8 – Functional flow chart.



APPLICATIONS INFORMATION (CONTINUED)

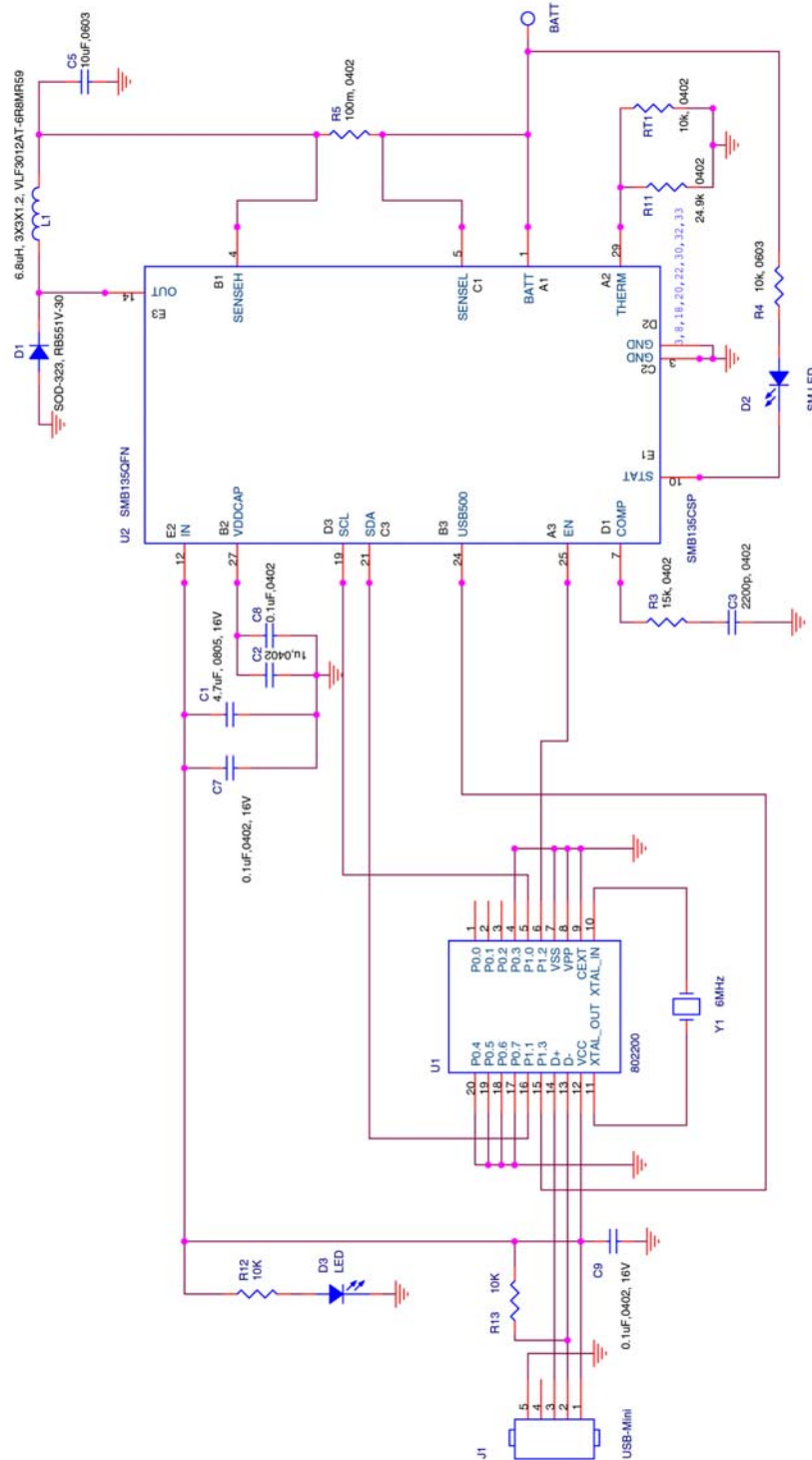

Figure 9 – Typical applications schematic. The USB device has internal pull up resistors for SDA and SCL.

**APPLICATIONS INFORMATION (CONTINUED)****Table 1: Recommended Bill of Material.**

Item	Description	Vendor / Part Number	Qty	Ref. Des.
Resistors				
1	15kohm, 1%, 0402	Vishay# CRCW04021502F	1	R3
2	10kohm, 1%, 0402	Vishay# CRCW04021002F	3	R4, R12, R13
3	100mohm, 1%, 0402, 1/6W	Susumu# RP1005S-R10-F-C	1	R5
4	24.9kohm, 1%, 0402	Vishay# CRCW04022492F	1	R11
5	10kohm, Thermistor, 0402	TDK# NTCG103JF103FT	1	RT1
Capacitors				
6	10uF, 0603, X5R, 6.3V, Ceramic	TDK# C1608X5R0J106M	1	C5
7	4.7uF, 0805, X5R, 16V, Ceramic	Murata# GRM40X5R475K16D520	1	C1
8	1uF, 0402, X5R, 10V, Ceramic	Panasonic# ECJ-0EB1A105M	1	C2
9	2200pF, 0402, X5R, 25V, Ceramic	Vishay# VJ0402Y222KXXA	1	C3
10	0.1uF, 0402, X7R, 16V, Ceramic	Kemet# C0402C104K4RACTU	3	C7, C8, C9
Semiconductors				
11	RB551V-30, SOD-323, 30V, 0.5A, 0.47Vf	ROHM# RB551V-30TE-17	1	D1
12	LED, Red, SMD, 0805	Lumex# SML-LXT0805SRW	1	D2
13	Cypress CY7C63001A USB to I ² C Micro	Delcom Engineering #802200	1	U1
14	Crystal Oscillator, SMT, 6MHz	Digikey# 300-6112-1-ND	1	Y1
15	SMB135E	Summit Microelectronics	1	U2
Magnetics				
16	6.8uH, 0.96A (saturation), 0.97A (dc)	TDK# VLF4012AT-6R8MR96	1	L1
	4.7uH, 1.02A (saturation), 1.04A (dc)	Taiyo Yuden # NR3015T4R7M	1	L1 (Alternate)
Hardware				
17	Connector Receptacle Mini USB type B 2.0	Digi-Key, H2960CT-ND Hirose Electric USA UX60-MB-5S8 H2960CT	1	J1



LAYOUT – TOP SIDE

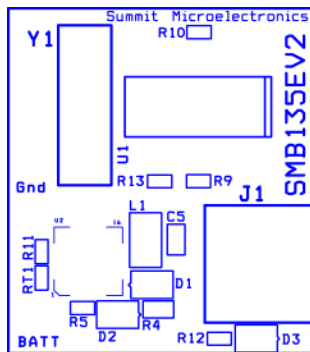

Stack up
Top
Ground
Power
Bottom

Use blue solder mask
Use 2 oz. copper
Use hot air solder over copper
Use standard FR4 material
Four Layer Board
Standard 62 mils in thickness

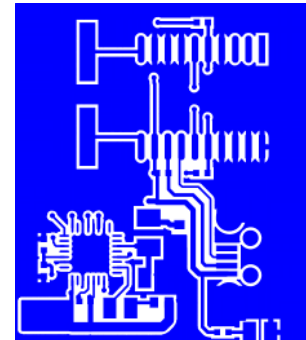

Figure 10 – Example Layout. The top side layout provides space (U2) for an SMB135 device packaged in a leadless QFN package (Not to Scale).

LAYOUT – BOTTOM SIDE

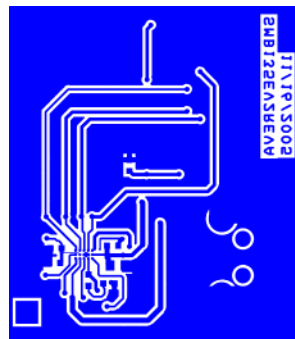
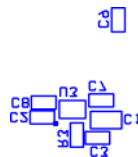

Figure 11 – Example Layout. The bottom side layout provides space (U3) for a SMB135E device packaged in a CSP package.



DEVELOPMENT HARDWARE & SOFTWARE

The SMX3202 system consists of a USB programming Dongle, cable and Windows™ GUI software. It can be ordered on the website or from a local representative. The latest revisions of all software and an application brief describing the SMX3202 is available from the website (www.summitmicro.com).

The SMX3202 programming Dongle/cable interfaces directly between a PC's USB port and the target application. The device is then configured on-screen via an intuitive graphical user interface employing drop-down menus.

The Windows GUI software will generate the data and send it in I²C serial bus format so that it can be directly downloaded to the SMB135 via the programming Dongle and cable. An example of the connection interface is shown in Figure 12.

When design prototyping is complete, the software can generate a HEX data file that should be transmitted to Summit for approval. Summit will then assign a unique customer ID to the HEX code and program production devices before the final electrical test operations. This will ensure proper device operation in the end application.

Top view of straight 0.1" x 0.1" closed-side connector. SMX3202 interface connector.

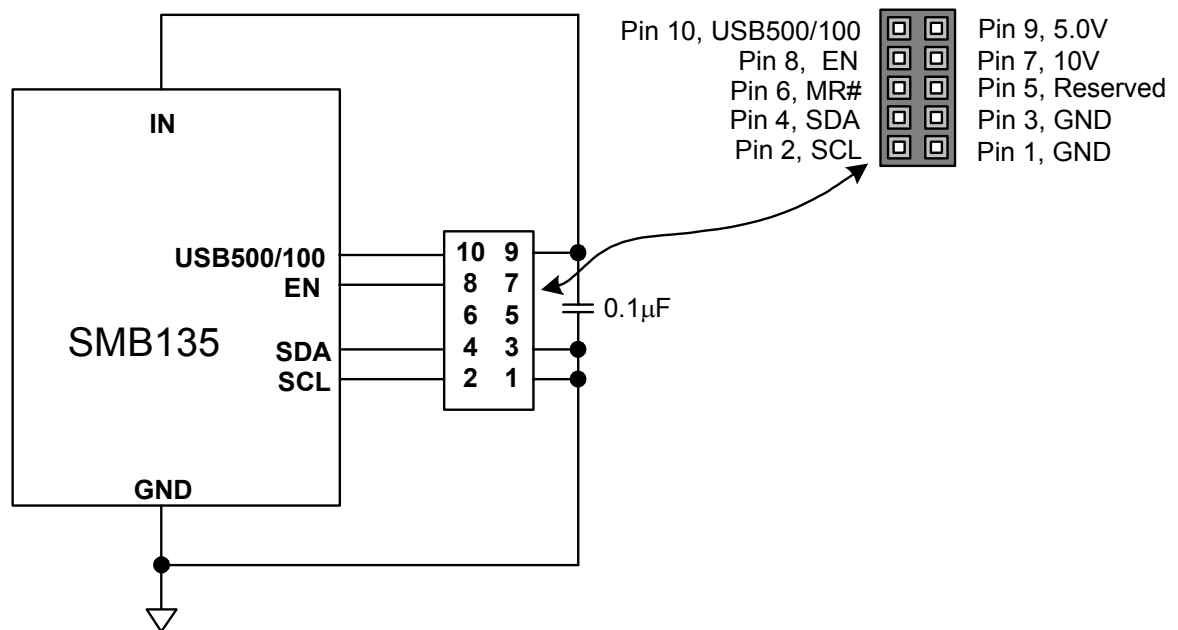

Figure 12 – SMX3202 Programmer I²C serial bus connections to program the SMB135. Only SDA and SCL connections are necessary for programming purposes, the other 2 pins are control options provided by the SMX3202 and Windows GUI, see pin descriptions



I²C PROGRAMMING INFORMATION

SERIAL INTERFACE

Access to the configuration registers, command and status registers is carried out over an industry standard 2-wire serial interface (I²C). SDA is a bi-directional data line and SCL is a clock input (Figure 4). Data is clocked in on the rising edge of SCL and clocked out on the falling edge of SCL. All data transfers begin with the MSB. During data transfers, SDA must remain stable while SCL is high. Data is transferred in 8-bit packets with an intervening clock period in which an Acknowledge is provided by the device receiving data. The SCL high period (t_{HIGH}) is used for generating Start and Stop conditions that precede and end most transactions on the serial bus. A high-to-low transition of SDA while SCL is high is considered a Start condition while a low-to-high transition of SDA while SCL is high is considered a Stop condition.

The interface protocol allows operation of multiple devices and types of devices on a single bus through unique device addressing. The address byte is comprised of a 7-bit device type identifier (slave address). The remaining bit indicates either a read or a write operation. Refer to Table 1 for a description of the address bytes used by the SMB135.

The device type identifier for the configuration registers and the command and status registers are accessible with the same slave address. The slave address can be programmed to any seven bit number 0000000_{BIN} through 1111111_{BIN} . Table 2.

WRITE

Writing to a configuration register is illustrated in Figures 13 and 14. A Start condition followed by the slave address byte is provided by the host; the SMB135 responds with an Acknowledge; the host then responds by sending the memory address pointer or configuration register address pointer; the SMB135 responds with an acknowledge; the host then clocks in one byte of data. For configuration register writes, up to 15 additional bytes of data can be clocked in by the host to write to consecutive addresses within the same page.

After the last byte is clocked in and the host receives an Acknowledge, a Stop condition must be issued to initiate the nonvolatile write operation.

READ

The address pointer for the non-volatile configuration registers and memory registers as well as the volatile command and status registers must be set before data can be read from the SMB135. This is accomplished by issuing a dummy write command, which is a write command that is not followed by a Stop condition. A dummy write command sets the address from which data is read. After the dummy write command is issued, a Start command followed by the address byte is sent from the host. The host then waits for an Acknowledge and then begins clocking data out of the slave device. The first byte read is data from the address pointer set during the dummy write command. Additional bytes can be clocked out of consecutive addresses with the host providing an Acknowledge after each byte. After the data is read from the desired registers, the read operation is terminated by the host holding SDA high during the Acknowledge clock cycle and then issuing a Stop condition. Refer to Figure 15 for an illustration of the read sequence.

CONFIGURATION REGISTERS

Writing and reading the configuration registers is shown in Figures 13, 14 and 15. A description of the configuration registers is shown in Table 3 through Table 12.

GRAPHICAL USER INTERFACE (GUI)

Device configuration utilizing the Windows based SMB135 graphical user interface (GUI) is highly recommended. The software is available from the Summit website (www.summitmicro.com). Using the GUI in conjunction with this datasheet, simplifies the process of device prototyping and the interaction of the various functional blocks. A programming Dongle (SMX3202) is available from Summit to communicate with the SMB135. The Dongle connects directly to the USB port of a PC and programs the device through a cable using the I²C bus protocol. See Figure 12 and the SMX3202 Data Sheet.

Slave Address	Register Type
ANY	Configuration Registers are located in 00_{HEX} thru 05_{HEX} , 08_{HEX} and $0F_{HEX}$

Table 2 – Address bytes used by the SMB135.



I²C PROGRAMMING INFORMATION (CONTINUED)

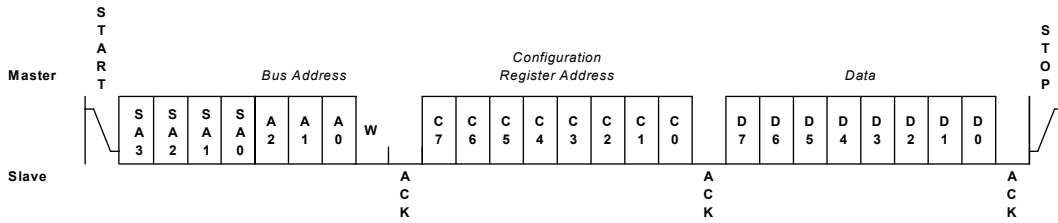

Figure 13 – Configuration Register Byte Write

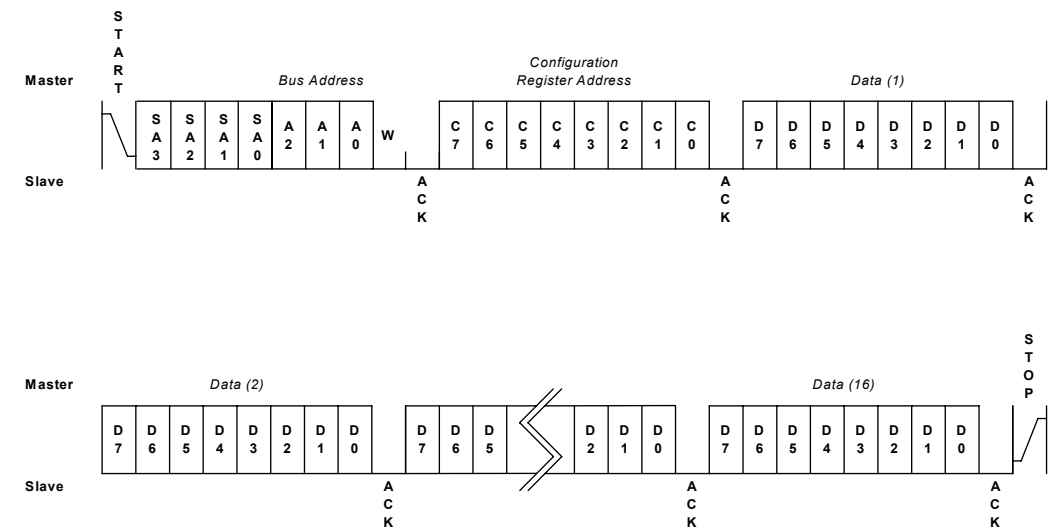

Figure 14 – Configuration Register Page Write

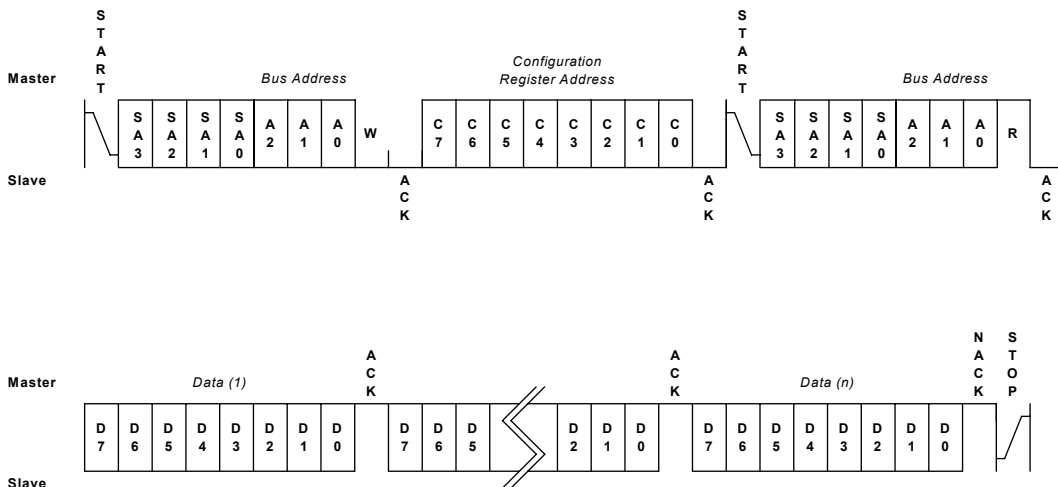

Figure 15 – Configuration Register Read



CONFIGURATION REGISTERS

The following tables (Tables 3 to 15) describe the user-programmable registers of the SMB135 programmable battery charger. Locations 00-0F are non-volatile, EEPROM registers; however, registers 00-07, which contain the battery charging parameters, may also be configured to be programmable in RAM. Locations 31-3F contain volatile status and command registers. To lock all of the configuration registers, set 0E[2]=1; **please note that this operation cannot be undone**. To allow volatile access to locations 00-07, set 0E[0]=1; then after every power-on, 31[7] must also be set high. **It is prohibited to write to any location, not specifically mentioned in the tables below**⁷. Default register settings are in **BOLD**.

Table 3 – Charge current – 8-bit (address: 00h) – Non-Volatile & Volatile (mirror)									
Bit7	Bit6	Bit5	Bit4	Bit3	Bit2	Bit1	Bit0	Fast Charge Current	
								R _{SENSE} =100mΩ	R _{SENSE} =50mΩ
0	0	0	0	X	X	X	X	47.5mA	95mA
0	0	0	1	X	X	X	X	62.5mA	125mA
0	0	1	0	X	X	X	X	65.0mA	130mA
0	0	1	1	X	X	X	X	67.5mA	135mA
0	1	0	0	X	X	X	X	195mA	390mA
0	1	0	1	X	X	X	X	225mA	450mA
0	1	1	0	X	X	X	X	255mA	510mA
0	1	1	1	X	X	X	X	285mA	570mA
1	0	0	0	X	X	X	X	315mA	630mA
1	0	0	1	X	X	X	X	345mA	690mA
1	0	1	0	X	X	X	X	375mA	750mA
1	0	1	1	X	X	X	X	405mA	810mA
1	1	0	0	X	X	X	X	435mA	870mA
1	1	0	1	X	X	X	X	465mA	930mA
1	1	1	0	X	X	X	X	495mA	990mA
1	1	1	1	X	X	X	X	525mA	1050mA
Bit7	Bit6	Bit5	Bit4	Bit3	Bit2	Bit1	Bit0	Pre-charge current	
								R _{SENSE} =100mΩ	R _{SENSE} =50mΩ
X	X	X	X	0	0	0	0	25mA	50mA
X	X	X	X	0	0	0	1	37.5mA	75mA
X	X	X	X	0	0	1	0	50mA	100mA
X	X	X	X	0	0	1	1	62.5mA	125mA
X	X	X	X	0	1	0	0	75mA	150mA
X	X	X	X	0	1	0	1	87.5mA	175mA
X	X	X	X	0	1	1	0	100mA	200mA
X	X	X	X	0	1	1	1	112.5mA	225mA
X	X	X	X	1	0	0	0	125mA	250mA
X	X	X	X	1	0	0	1	137.5mA	275mA
X	X	X	X	1	0	1	0	150mA	300mA
X	X	X	X	1	0	1	1	162.5mA	325mA
X	X	X	X	1	1	0	0	175mA	350mA
X	X	X	X	1	1	0	1	187.5mA	375mA
X	X	X	X	1	1	1	0	200mA	400mA
X	X	X	X	1	1	1	1	212.5mA	425mA

Note 7: Never Write to Reserved bits. Note 8: Charge current can be limited by internal current limit under certain conditions.

**CONFIGURATION REGISTERS (CONT.)****Table 4 – Termination current – 8-bit (address: 01h) – Non-Volatile & Volatile (mirror)**

Bit7	Bit6	Bit5	Bit4	Bit3	Bit2	Bit1	Bit0	Termination Current	
								R _{SENSE} =100mΩ	R _{SENSE} =50mΩ
X	X	X	X	X	0	0	0	25mA	50mA
X	X	X	X	X	0	0	1	40mA	80mA
X	X	X	X	X	0	1	0	55mA	110mA
X	X	X	X	X	0	1	1	70mA	140mA
X	X	X	X	X	1	0	0	85mA	170mA
X	X	X	X	X	1	0	1	100mA	200mA
X	X	X	X	X	1	1	0	115mA	230mA
X	X	X	X	X	1	1	1	130mA	260mA

Note 7: Never Write to Reserved bits.



CONFIGURATION REGISTERS (CONT.)

Table 5 – Float Voltage – 8-bit (address: 02h) – Non-Volatile & Volatile (mirror)

Bit7	Bit6	Bit5	Bit4	Bit3	Bit2	Bit1	Bit0	Float Voltage
X	X	X	0	0	0	0	0	3.850V
X	X	X	0	0	0	0	1	4.020V
X	X	X	0	0	0	1	0	4.040V
X	X	X	0	0	0	1	1	4.060V
X	X	X	0	0	1	0	0	4.080V
X	X	X	0	0	1	0	1	4.100V
X	X	X	0	0	1	1	0	4.120V
X	X	X	0	0	1	1	1	4.140V
X	X	X	0	1	0	0	0	4.160V
X	X	X	0	1	0	0	1	4.180V
X	X	X	0	1	0	1	0	4.200V
X	X	X	0	1	0	1	1	4.220V
X	X	X	0	1	1	0	0	4.240V
X	X	X	0	1	1	0	1	4.260V
X	X	X	0	1	1	1	0	4.280V
X	X	X	0	1	1	1	1	4.300V
X	X	X	1	0	0	0	0	4.320V
X	X	X	1	0	0	0	1	4.340V
X	X	X	1	0	0	1	0	4.360V
X	X	X	1	0	0	1	1	4.380V
X	X	X	1	0	1	0	0	4.400V
X	X	X	1	0	1	0	1	4.420V
X	X	X	1	0	1	1	0	4.440V
X	X	X	1	0	1	1	1	4.460V
X	X	X	1	1	0	0	0	4.480V
X	X	X	1	1	0	0	1	4.500V
X	X	X	1	1	0	1	0	4.520V
X	X	X	1	1	0	1	1	4.540V
X	X	X	1	1	1	0	0	4.560V
X	X	X	1	1	1	0	1	4.580V
X	X	X	1	1	1	1	0	4.600V
X	X	X	1	1	1	1	1	4.620V

Note 7: Never Write to Reserved bits.



CONFIGURATION REGISTERS (CONT.)

Table 6 – Other Charging Parameters – 8-bit (address: 03h) – Non-Volatile & Volatile (mirror)								
Bit7	Bit6	Bit5	Bit4	Bit3	Bit2	Bit1	Bit0	Automatic Recharge
0	X	X	X	X	X	X	X	Enabled
1	X	X	X	X	X	X	X	Disabled
Bit7	Bit6	Bit5	Bit4	Bit3	Bit2	Bit1	Bit0	Current Termination
X	0	X	X	X	X	X	X	Enabled
X	1	X	X	X	X	X	X	Disabled
Bit7	Bit6	Bit5	Bit4	Bit3	Bit2	Bit1	Bit0	Pre-charge to Fast-charge Voltage Threshold
X	X	0	0	0	X	X	X	2.4V
X	X	0	0	1	X	X	X	2.5V
X	X	0	1	0	X	X	X	2.6V
X	X	0	1	1	X	X	X	2.7V
X	X	1	0	0	X	X	X	2.8V
X	X	1	0	1	X	X	X	2.9V
X	X	1	1	0	X	X	X	3.0V
X	X	1	1	1	X	X	X	3.1V
Bit7	Bit6	Bit5	Bit4	Bit3	Bit2	Bit1	Bit0	Hold-off Timer
X	X	X	X	X	X	0	X	<1msec (short)
X	X	X	X	X	X	1	X	256msec (long)

Table 7 – Cell temperature monitor – 8-bit (address: 04h) – Non-Volatile & Volatile (mirror)								
Bit7	Bit6	Bit5	Bit4	Bit3	Bit2	Bit1	Bit0	Thermistor Current
0	0	X	X	X	X	X	X	100µA (10k NTC)
0	1	X	X	X	X	X	X	40µA (25k NTC)
1	0	X	X	X	X	X	X	10µA (100k NTC)
1	1	X	X	X	X	X	X	0µA (Disabled)
Bit7	Bit6	Bit5	Bit4	Bit3	Bit2	Bit1	Bit0	Low Temperature Alarm Trip Point
X	X	0	0	0	X	X	X	-20°C
X	X	0	0	1	X	X	X	-15°C
X	X	0	1	0	X	X	X	-10°C
X	X	0	1	1	X	X	X	-5°C
X	X	1	0	0	X	X	X	0°C
X	X	1	0	1	X	X	X	+5°C
X	X	1	1	0	X	X	X	+10°C
X	X	1	1	1	X	X	X	+15°C
Bit7	Bit6	Bit5	Bit4	Bit3	Bit2	Bit1	Bit0	High Temperature Alarm Trip Point
X	X	X	X	X	0	0	0	+30°C
X	X	X	X	X	0	0	1	+35°C
X	X	X	X	X	0	1	0	+40°C
X	X	X	X	X	0	1	1	+45°C
X	X	X	X	X	1	0	0	+50°C
X	X	X	X	X	1	0	1	+55°C
X	X	X	X	X	1	1	0	+60°C
X	X	X	X	X	1	1	1	+65°C

Note 7: Never Write to Reserved bits.



CONFIGURATION REGISTERS (CONT.)

Table 8 – Battery charging control – 8-bit (address: 05h) – Non-Volatile & Volatile (mirror)								
Bit7	Bit6	Bit5	Bit4	Bit3	Bit2	Bit1	Bit0	Status Output
0	X	X	X	X	X	X	X	STAT is active low while charging, active high all other times
1	X	X	X	X	X	X	X	STAT blinks while charging, is active low when finished, active high when disabled
Bit7	Bit6	Bit5	Bit4	Bit3	Bit2	Bit1	Bit0	Glitch Filter
X	X	0	X	X	X	X	X	Glitch filter enabled
X	X	1	X	X	X	X	X	Glitch filter disabled
Bit7	Bit6	Bit5	Bit4	Bit3	Bit2	Bit1	Bit0	Fast-charge Timeout
X	X	X	X	0	0	X	X	350 min
X	X	X	X	0	1	X	X	699 min
X	X	X	X	1	0	X	X	1398 min
X	X	X	X	1	1	X	X	Disabled
Bit7	Bit6	Bit5	Bit4	Bit3	Bit2	Bit1	Bit0	Pre-charge Timeout
X	X	X	X	X	X	0	0	44 min
X	X	X	X	X	X	0	1	87 min
X	X	X	X	X	X	1	0	175 min
X	X	X	X	X	X	1	1	Disabled

Table 9 – STAT and USB500/100 Settings – 8-bit (address: 07h) – Non-Volatile								
Bit7	Bit6	Bit5	Bit4	Bit3	Bit2	Bit1	Bit0	STAT Output Indicator
X	X	X	X	X	0	X	X	Battery charge status
X	X	X	X	X	1	X	X	Input over-voltage or input under-voltage
Bit7	Bit6	Bit5	Bit4	Bit3	Bit2	Bit1	Bit0	Battery over-voltage Behavior
X	X	X	X	X	X	0	X	Charger is not shutdown
X	X	X	X	X	X	1	X	Charger is shutdown
Bit7	Bit6	Bit5	Bit4	Bit3	Bit2	Bit1	Bit0	USB500/100 Control
X	X	X	X	X	X	X	0	USB500/100 input pin
X	X	X	X	X	X	X	1	USB500/100 register (address 31h)

Table 10 – Frequency Selection – 8-bit (address: 08h) – Non-Volatile								
Bit7	Bit6	Bit5	Bit4	Bit3	Bit2	Bit1	Bit0	Switching Frequency
0	0	X	X	X	X	X	X	750kHz
0	1	X	X	X	X	X	X	1000kHz
1	0	X	X	X	X	X	X	1250kHz
1	1	X	X	X	X	X	X	1250kHz

Note 7: Never Write to Reserved bits.



CONFIGURATION REGISTERS (CONT.)

Table 11 – Configuration and User Memory Lock – 8-bit (address: 0Eh) – Non-Volatile								
Bit7	Bit6	Bit5	Bit4	Bit3	Bit2	Bit1	Bit0	Configuration Lock
X	X	X	X	X	0	X	X	Unlocked – user can write to non-volatile Configuration bits
X	X	X	X	X	1	X	X	Locked – user cannot write to non-volatile Configuration bits
Bit7	Bit6	Bit5	Bit4	Bit3	Bit2	Bit1	Bit0	User-Memory Lock
X	X	X	X	X	X	0	X	Unlocked – user can write to general purpose EE bits (h20-h2F)
X	X	X	X	X	X	1	X	Locked – user cannot write to general purpose EE bits (h20-h2F)
Bit7	Bit6	Bit5	Bit4	Bit3	Bit2	Bit1	Bit0	Volatile Writes Permission
X	X	X	X	X	X	X	0	Do not allow volatile writes to registers h00-h07
X	X	X	X	X	X	X	1	Allow volatile writes to registers h00-h07 (even if h0E[2]=1)

Table 12 – EN Polarity & I ² C Bus/Slave Address – 8-bit (address: 0Fh) – Non-Volatile								
Bit7	Bit6	Bit5	Bit4	Bit3	Bit2	Bit1	Bit0	EN (Enable) Polarity (Register 31[4])
0	X	X	X	X	X	X	X	Active Low
1	X	X	X	X	X	X	X	Active High
Bit7	Bit6	Bit5	Bit4	Bit3	Bit2	Bit1	Bit0	I ² C Bus Address
X	0	0	0	X	X	X	X	000
X	0	0	1	X	X	X	X	001
X	0	1	0	X	X	X	X	010
X	0	1	1	X	X	X	X	011
X	1	0	0	X	X	X	X	100
X	1	0	1	X	X	X	X	101
X	1	1	0	X	X	X	X	110
X	1	1	1	X	X	X	X	111
Bit7	Bit6	Bit5	Bit4	Bit3	Bit2	Bit1	Bit0	I ² C Slave Address
X	X	X	X	0	0	0	0	0000
X	X	X	X	0	0	0	1	0001
X	X	X	X	0	0	1	0	0010
X	X	X	X	0	0	1	1	0011
X	X	X	X	0	1	0	0	0100
X	X	X	X	0	1	0	1	0101
X	X	X	X	0	1	1	0	0110
X	X	X	X	0	1	1	1	0111
X	X	X	X	1	0	0	0	1000
X	X	X	X	1	0	0	1	1001
X	X	X	X	1	0	1	0	1010
X	X	X	X	1	0	1	1	1011
X	X	X	X	1	1	0	0	1100
X	X	X	X	1	1	0	1	1101
X	X	X	X	1	1	1	0	1110
X	X	X	X	1	1	1	1	1111

Note 7: Never Write to Reserved bits.



CONFIGURATION STATUS REGISTERS

Table 13 – Volatile Configuration & Charger Enable – 8-bit (address: 31h) – Volatile

Bit7	Bit6	Bit5	Bit4	Bit3	Bit2	Bit1	Bit0	Volatile Configuration
0	X	X	X	X	X	X	X	Volatile writes to h00-h07 are disabled
1	X	X	X	X	X	X	X	Volatile writes to h00-h07 are enabled (if CFG h0E[0]=1)
Bit7	Bit6	Bit5	Bit4	Bit3	Bit2	Bit1	Bit0	Charger Enable
X	X	X	0	X	X	X	X	Enabled if 0F[7]=0; Disabled if 0F[7]=1
X	X	X	1	X	X	X	X	Disabled if 0F[7]=0; Enabled if 0F[7]=1
Bit7	Bit6	Bit5	Bit4	Bit3	Bit2	Bit1	Bit0	USB500/100 Select (This bit only has an effect when CFG 07[0]=1)
X	X	X	X	0	X	X	X	USB 100mA current level
X	X	X	X	1	X	X	X	USB 500mA current level

Table 14 – Battery status register A – 8-bit (address: 36h) – Volatile (read only)

Bit7	Bit6	Bit5	Bit4	Bit3	Bit2	Bit1	Bit0	Charging Status
1	X	X	X	X	X	X	X	Charger has completed at least 1 successful charge since being enabled
X	1	X	X	X	X	X	X	Charger has completed at least 1 re-charge cycle since being enabled
Bit7	Bit6	Bit5	Bit4	Bit3	Bit2	Bit1	Bit0	Timeout Status
X	X	0	0	X	X	X	X	No timeouts have occurred
X	X	0	1	X	X	X	X	Pre-charge timeout
X	X	1	0	X	X	X	X	Fast-charge timeout
Bit7	Bit6	Bit5	Bit4	Bit3	Bit2	Bit1	Bit0	Temperature Fault
X	X	X	X	1	X	X	X	Charger paused – temperature fault
Bit7	Bit6	Bit5	Bit4	Bit3	Bit2	Bit1	Bit0	Charging Status
X	X	X	X	X	0	0	X	Idle
X	X	X	X	X	0	1	X	Pre-charging
X	X	X	X	X	1	0	X	Fast-charging
X	X	X	X	X	1	1	X	Taper-charging
Bit7	Bit6	Bit5	Bit4	Bit3	Bit2	Bit1	Bit0	Charging Status
X	X	X	X	X	X	X	1	Charger is enabled

Table 15 – Battery status register B – 8-bit (address: 37h) – Volatile (read only)

Bit7	Bit6	Bit5	Bit4	Bit3	Bit2	Bit1	Bit0	Fault Output
1	X	X	X	X	X	X	X	Battery missing
X	1	X	X	X	X	X	X	Charging error
X	X	1	X	X	X	X	X	Battery over-voltage condition
X	X	X	1	X	X	X	X	Charger over-voltage condition
X	X	X	X	1	X	X	X	Charger under-voltage condition
X	X	X	X	X	1	X	X	Over-temperature alarm
X	X	X	X	X	X	1	X	Under-temperature alarm
X	X	X	X	X	X	X	1	Termination Detect Current Threshold has been hit

Note 7: Never Write to Reserved bits.



DEFAULT CONFIGURATION REGISTER SETTINGS – SMB135E-470V							
Register	Content	Register	Content	Register	Content	Register	Content
R00	F6	R04	E4	R08	80	R0C	01
R01	00	R05	0F	R09	00	R0D	E1
R02	0A	R06	00	R0A	00	R0E	01
R03	F0	R07	01	R0B	C8	R0F	80

Table 16 - The default device ordering number is SMB135E-470V. It is programmed with the register contents as shown above and guaranteed over the industrial temperature range. The ordering number is derived from the customer supplied hex file. New device suffix numbers (nnn) are assigned to non-default requirements. Default register settings are shown in the register Tables 3 through 15 as BOLD.



PACKAGE DRAWING

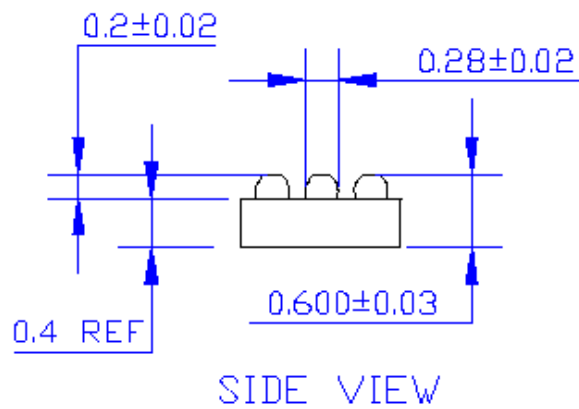
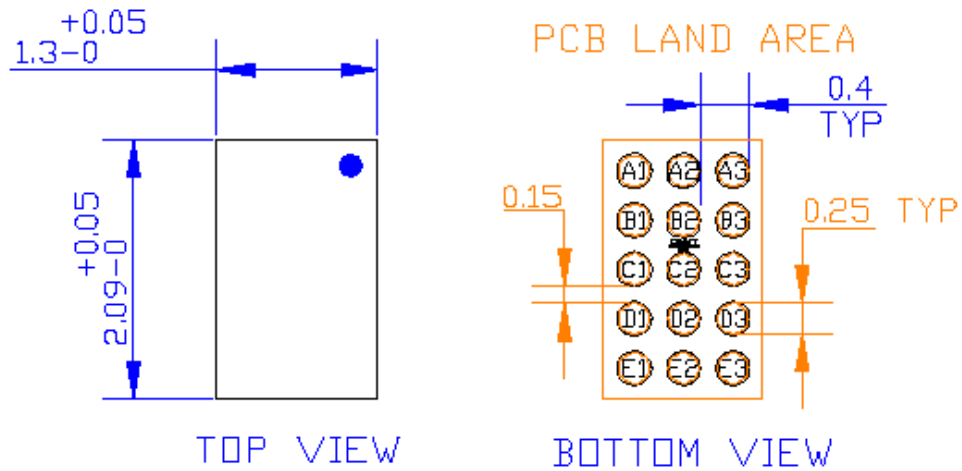

NOTES: ALL DIMENSIONS ARE [MM]

15-Ball Ultra CSP™



PACKAGE DRAWING (CONT.)

QFN 32 pads
0.5mm Pitch

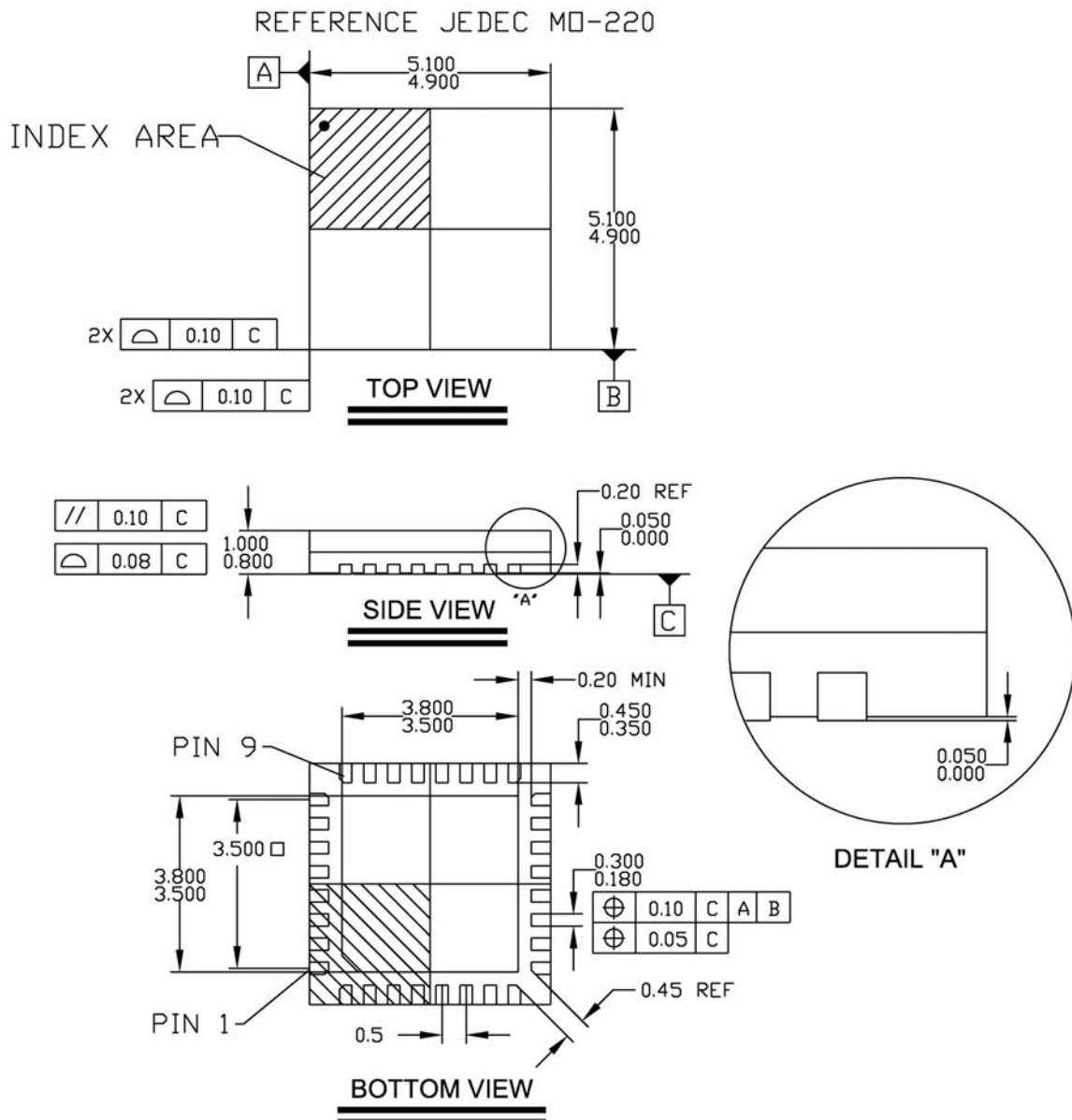

NOTES: ALL DIMENSIONS ARE mm [MAX] [MIN]



PART MARKING

Note: Subject to change at any time during production

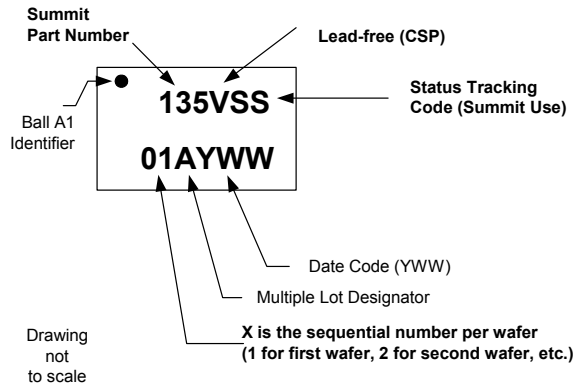

ORDERING INFORMATION

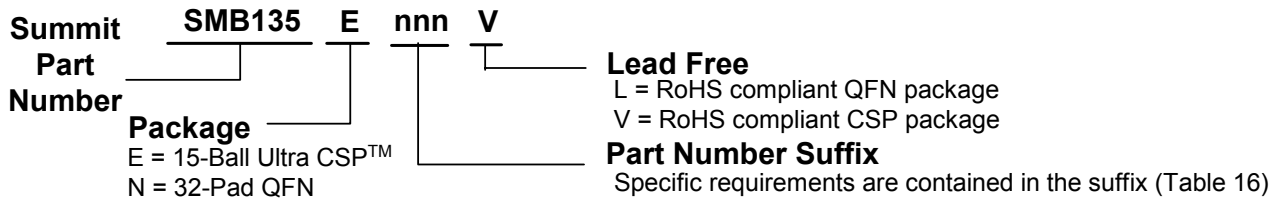

NOTICE

NOTE 1 – This is a data sheet that describes a Summit that is in production.

SUMMIT Microelectronics, Inc. reserves the right to make changes to the products contained in this publication in order to improve design, performance or reliability. SUMMIT Microelectronics, Inc. assumes no responsibility for the use of any circuits described herein, conveys no license under any patent or other right, and makes no representation that the circuits are free of patent infringement. Charts and schedules contained herein reflect representative operating parameters, and may vary depending upon a user's specific application. While the information in this publication has been carefully checked, SUMMIT Microelectronics, Inc. shall not be liable for any damages arising as a result of any error or omission.

SUMMIT Microelectronics, Inc. does not recommend the use of any of its products in life support or aviation applications where the failure or malfunction of the product can reasonably be expected to cause any failure of either system or to significantly affect their safety or effectiveness. Products are not authorized for use in such applications unless SUMMIT Microelectronics, Inc. receives written assurances, to its satisfaction, that: (a) the risk of injury or damage has been minimized; (b) the user assumes all such risks; and (c) potential liability of SUMMIT Microelectronics, Inc. is adequately protected under the circumstances.

Revision 3.1 – This document supersedes all previous versions. Please check the Summit Microelectronics Inc. web site at www.summitmicro.com for data sheet updates.

© Copyright 2006 SUMMIT MICROELECTRONICS, Inc. **PROGRAMMABLE POWER FOR A GREEN PLANET™**

I²C is a trademark of Philips Corporation