

SLF Series



SLF series is designed for low profile type with low Rdc and large current. Its magnetic shielded type is suitable for high-density mounting and flat bottom surface allows for reliable mounting onto the board. Soldering conditions can be easily confirmed when mounting onto the board. This series also provides customers with embossed carrier type packaging for automatic mounting machine.

Features

- RoHS compliant
- Low resistance and high rated currents

Applications

- Portable telephones
- Computers
- Hard disk drives and other electronic devices

Products Identification

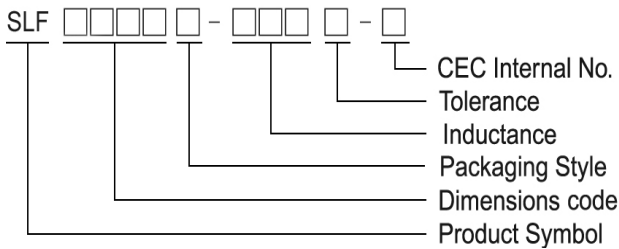

- Packaging: T : Tape and Reel

Shape and Dimensions

SLF 0628

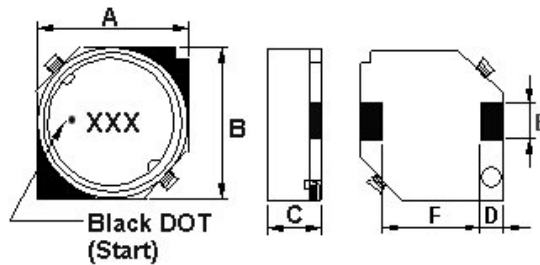

Dimension in mm

TYPE	A	B	C	D	E	F
SLF 0628	6 ± 0.2	6 ± 0.2	2.8 ± 0.2	1.5 TYP	2 ± 0.1	3.0 TYP

SLF0728/ 0732/ 0745/ 0730

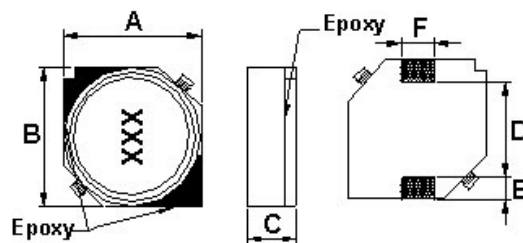

Dimension in mm

TYPE	A	B	C	D	E	F
SLF 0728	7 ± 0.2	7 ± 0.2	2.8 ± 0.2	4.9 TYP	0.9TYP	2.0 TYP
SLF 0730	7 ± 0.2	7 ± 0.2	3.0 ± 0.2	4.9 TYP	0.9TYP	2.0 TYP
SLF 0732	7 ± 0.2	7 ± 0.2	3.2 ± 0.2	4.9 TYP	0.9TYP	2.0 TYP
SLF 0745	7 ± 0.2	7 ± 0.2	4.5 ± 0.3	4.9 TYP	0.9TYP	2.0 TYP

Shape and Dimensions

SLF 1045/ 1055

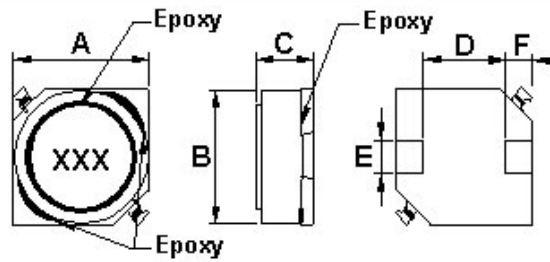

Dimension in mm

TYPE	A	B	C	D	E	F
SLF 1045	10.1 ± 0.3	10.1 ± 0.3	4.5 ± 0.3	6.0 TYP	3.0 TYP	2 TYP
SLF 1055	10.1 ± 0.3	10.1 ± 0.3	5.5 ± 0.3	6.0 TYP	3.0 TYP	2 TYP

SLF 0755/ 1255/ 1265/ 1275

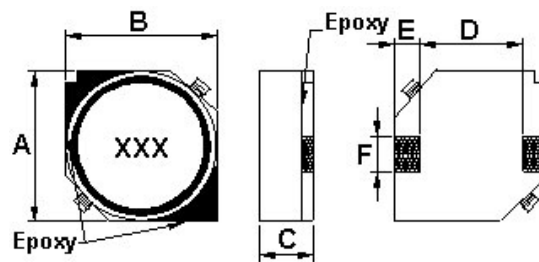

Dimension in mm

TYPE	A	B	C	D	E	F
SLF 0755	7.0 ± 0.2	7.0 ± 0.2	5.5 ± 0.3	4.9 TYP	0.9 TYP	2.0 TYP
SLF 1255	12.5 ± 0.3	12.5 ± 0.3	5.5 ± 0.3	8.6 TYP	2.0 TYP	3.0 TYP
SLF 1265	12.5 ± 0.3	12.5 ± 0.3	6.5 ± 0.35	8.6 TYP	2.0 TYP	3.0 TYP
SLF 1275	12.5 ± 0.3	12.5 ± 0.3	7.5 ± 0.35	8.6 TYP	2.0 TYP	3.0 TYP

Recommended Pattern

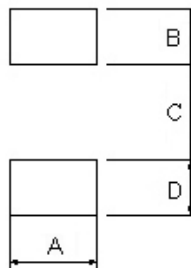

Dimension in mm

TYPE	A	B	C	D
SLF 0628	2.2	1.5	4.0	1.5
SLF 0728	2.2	1.5	4.9	1.5
SLF 0730	2.2	1.5	4.9	1.5
SLF 0732	2.2	1.5	4.9	1.5
SLF 0745	2.2	1.5	4.9	1.5
SLF 0755	2.2	1.5	4.9	1.5
SLF 1045	3.2	2.5	5.6	2.5
SLF 1045	3.2	2.5	5.6	2.5
SLF 1105	3.2	2.5	5.6	2.5
SLF 1255	3.2	2.5	8.6	2.5
SLF 1265	3.2	2.5	8.6	2.5
SLF 1275	3.2	2.5	8.6	2.5

Electrical Characteristics

Part Number	Inductance (μ H)	Tolerance (\pm %)	Test Frequency (KHz)	DC Resistance (Ω \pm 20%)	Isat (A)	Itemp (A) Max
SLF0628T-4R7M-N	4.7	20	1	0.0284	1.6	2.5
SLF0628T-6R8M-N	6.8	20	1	0.0354	1.5	2.2
SLF0628T-100M-N	10	20	1	0.0532	1.3	1.8
SLF0628T-150M-N	15	20	1	0.0745	1.0	1.4
SLF0628T-220M-N	22	20	1	0.104	0.77	1.3
SLF0628T-330M-N	33	20	1	0.148	0.69	1.1
SLF0628T-470M-N	47	20	1	0.21	0.59	0.92
SLF0628T-680M-N	68	20	1	0.29	0.50	0.78
SLF0628T-101M-N	100	20	1	0.43	0.42	0.64

- Tolerance: M = \pm 20%
- Isat: Value obtained when DC current flows and the initial value of inductance has fallen by 30%
- Itemp current: Value obtained when current flows and the temperature has risen to 25°C
- Test equipment Inductance: HP4284A LF impedance analyzer or equivalent (Test frequency:1KHz/0.5V)
- RDC: CH502BC

Electrical Characteristics

Part Number	Inductance (μ H)	Tolerance (\pm %)	Test Frequency (KHz)	DC Resistance (Ω \pm 20%)	Isat (A)
SLF0728T-3R3M-N	3.3	20	1	0.037	1.6
SLF0728T-4R7M-N	4.7	20	1	0.045	1.5
SLF0728T-6R8M-N	6.8	20	1	0.059	1.3
SLF0728T-100M-N	10	20	1	0.083	1.1
SLF0728T-150M-N	15	20	1	0.13	0.88
SLF0728T-220M-N	22	20	1	0.18	0.75
SLF0728T-330M-N	33	20	1	0.24	0.65
SLF0728T-470M-N	47	20	1	0.34	0.54

- Tolerance: M = \pm 20%
- Isat: Value obtained when DC current flows and the initial value of inductance has fallen by 10%
- Test equipment Inductance: HP4284A LF impedance analyzer or equivalent (Test frequency:1KHz/0.5V)
- RDC: CH502BC

Electrical Characteristics

Part Number	Inductance (μ H)	Tolerance (\pm %)	Test Frequency (KHz)	DC Resistance (Ω \pm 20%)	Isat (A)
SLF0730T-3R3M-N	3.3	20	1	0.023	1.8
SLF0730T-4R7M-N	4.7	20	1	0.036	1.6
SLF0730T-6R8M-N	6.8	20	1	0.041	1.5
SLF0730T-100M-N	10	20	1	0.060	1.3
SLF0730T-150M-N	15	20	1	0.084	1
SLF0730T-220M-N	22	20	1	0.15	0.86
SLF0730T-330M-N	33	20	1	0.16	0.65
SLF0730T-470M-N	47	20	1	0.24	0.57
SLF0730T-680M-N	68	20	1	0.31	0.49
SLF0730T-101M-N	100	20	1	0.45	0.35

- Tolerance: M = \pm 20%
- Isat: Value obtained when DC current flows and the initial value of inductance has fallen by 10%
- Test equipment Inductance: HP4284A LF impedance analyzer or equivalent (Test frequency:1KHz/0.5V)
- RDC: CH502BC

Electrical Characteristics

Part Number	Inductance (μH)	Tolerance ($\pm\%$)	Test Frequency (KHz)	DC Resistance ($\Omega\pm 20\%$)	Isat (A)
SLF0732T-2R2M-N	2.2	20	1	0.018	2.1
SLF0732T-3R3M-N	3.3	20	1	0.023	1.9
SLF0732T-4R7M-N	4.7	20	1	0.036	1.7
SLF0732T-6R8M-N	6.8	20	1	0.041	1.6
SLF0732T-100M-N	10	20	1	0.053	1.4
SLF0732T-150M-N	15	20	1	0.075	1.1
SLF0732T-220M-N	22	20	1	0.11	0.96
SLF0732T-330M-N	33	20	1	0.16	0.75
SLF0732T-470M-N	47	20	1	0.24	0.67
SLF0732T-680M-N	68	20	1	0.31	0.59
SLF0732T-101M-N	100	20	1	0.45	0.45
SLF0732T-151M-N	150	20	1	0.65	0.37
SLF0732T-221M-N	220	20	1	1.05	0.29
SLF0732T-331M-N	330	20	1	1.67	0.22
SLF0732T-471M-N	470	20	1	2.05	0.2
SLF0732T-681M-N	680	20	1	3.15	0.16
SLF0732T-102M-N	1000	20	1	4.78	0.13

- Tolerance: M = $\pm 20\%$
- Isat: Value obtained when DC current flows and the initial value of inductance has fallen by 10%
- Test equipment Inductance: HP4284A LF impedance analyzer or equivalent (Test frequency: 1KHz/0.5V)
- RDC: CH502BC

Electrical Characteristics

Part Number	Inductance (μH)	Tolerance ($\pm\%$)	Test Frequency (KHz)	DC Resistance ($\Omega\pm 20\%$)	Isat (A)	Itemp (A) Max
SLF0745T-3R3M-N	3.3	20	1	0.02	2.5	2.3
SLF0745T-4R7M-N	4.7	20	1	0.03	2	2.1
SLF0745T-6R8M-N	6.8	20	1	0.039	1.7	1.74
SLF0745T-100M-N	10	20	1	0.036	1.3	1.78
SLF0745T-150M-N	15	20	1	0.052	1.1	1.53
SLF0745T-220M-N	22	20	1	0.061	0.9	1.34
SLF0745T-330M-N	33	20	1	0.096	0.82	1.09
SLF0745T-470M-N	47	20	1	0.125	0.75	0.92
SLF0745T-680M-N	68	20	1	0.175	0.6	0.77
SLF0745T-101M-N	100	20	1	0.25	0.5	0.65
SLF0745T-151M-N	150	20	1	0.34	0.4	0.55
SLF0745T-221M-N	220	20	1	0.52	0.33	0.45
SLF0745T-331M-N	330	20	1	0.74	0.25	0.37
SLF0745T-471M-N	470	20	1	1.05	0.22	0.31
SLF0745T-681M-N	680	20	1	1.48	0.2	0.27
SLF0745T-102M-N	1000	20	1	2.28	0.14	0.25

- Tolerance: M = $\pm 20\%$
- Isat: Value obtained when DC current flows and the initial value of inductance has fallen by 10%
- Itemp current: Value obtained when current flows and the temperature has risen to 20°C
- Test equipment Inductance: HP4284A LF impedance analyzer or equivalent (Test frequency: 1KHz/0.5V)
- RDC: CH502BC

Electrical Characteristics

Part Number	Inductance (μ H)	Tolerance (\pm %)	Test Frequency (KHz)	DC Resistance (Ω)	Isat (A)	Itemp (A) Max
SLF0755T-1R5T-N	1.5	30	100	0.0174 \pm 30%	6.2	4.0
SLF0755T-2R2T-N	2.2	30	100	0.0217 \pm 30%	5.3	3.5
SLF0755T-3R3T-N	3.3	30	100	0.0240 \pm 30%	4.3	3.3
SLF0755T-4R7T-N	4.7	30	100	0.0280 \pm 30%	3.6	3.1
SLF0755T-6R8T-N	6.8	30	100	0.0340 \pm 30%	3.0	2.8
SLF0755T-100M-N	10	20	100	0.0391 \pm 20%	2.6	2.5
SLF0755T-150M-N	15	20	100	0.0508 \pm 20%	2.1	2.2
SLF0755T-220M-N	22	20	100	0.0643 \pm 20%	1.7	2.0
SLF0755T-470M-N	47	20	100	0.1550 \pm 20%	0.8	1.0

- Tolerance: T = \pm 30% , M = \pm 20% ,
- Isat: Value obtained when DC current flows and the initial value of inductance has fallen by 10%
- Itemp current : Value obtained when current flows and the temperature has risen to 30°C
- Test equipment Inductance: HP4284A LF impedance analyzer or equivalent (Test frequency: 100KHz/1V)
- RDC: CH502BC

Electrical Characteristics

Part Number	Inductance (μ H)	Tolerance (\pm %)	Test Frequency (KHz)	DC Resistance (Ω \pm 20%)	Isat (A)	Itemp (A) Max
SLF1045T-100M-N	10	20	1	0.0364	3	2.5
SLF1045T-150M-N	15	20	1	0.0472	2.4	2.2
SLF1045T-220M-N	22	20	1	0.0591	2.1	1.9
SLF1045T-330M-N	33	20	1	0.0815	1.6	1.7
SLF1045T-470M-N	47	20	1	0.1	1.4	1.5
SLF1045T-680M-N	68	20	1	0.14	1.2	1.3
SLF1045T-101M-N	100	20	1	0.2	1	1.1
SLF1045T-151M-N	150	20	1	0.35	0.79	0.81
SLF1045T-221M-N	220	20	1	0.47	0.65	0.7
SLF1045T-331M-N	330	20	1	0.68	0.54	0.58
SLF1045T-471M-N	470	20	1	1.03	0.47	0.47
SLF1045T-681M-N	680	20	1	1.6	0.38	0.38
SLF1045T-102M-N	1000	20	1	2.8	0.32	0.29
SLF1045T-152M-N	1500	20	1	3.4	0.22	0.26

- Tolerance: M = \pm 20%
- Isat: Value obtained when DC current flows and the initial value of inductance has fallen by 10%
- Itemp current: Value obtained when current flows and the temperature has risen to 30°C
- Test equipment Inductance: HP4284A LF impedance analyzer or equivalent (Test frequency:1KHz/0.5V)
- RDC: CH502BC

Electrical Characteristics

Part Number	Inductance (μ H)	Tolerance (\pm %)	Test Frequency (KHz)	DC Resistance (m Ω) Max	Isat (A)
SLF1055T-100M-N	10	20	1	40	3.5
SLF1055T-330M-N	33	20	1	85	2.1

- Tolerance: M = \pm 20%
- Isat: Value obtained when DC current flows and the initial value of inductance has fallen by 15%
- Test equipment Inductance: HP4284A LF impedance analyzer or equivalent (Test frequency:1KHz/0.5V)
- RDC:CH502BC digital

Electrical Characteristics

Part Number	Inductance (μ H)	Tolerance (\pm %)	Test Frequency (KHz)	DC Resistance (Ω \pm 20%)	Isat (A)	Itemp (A) Max
SLF1255T-6R0M-N	6	20	1	0.0164	3.6	4.9
SLF1255T-100M-N	10	20	1	0.0215	3.4	4.3
SLF1255T-150M-N	15	20	1	0.0259	2.8	3.9
SLF1255T-220M-N	22	20	1	0.0338	2.3	3.4
SLF1255T-330M-N	33	20	1	0.0415	1.9	3.1
SLF1255T-470M-N	47	20	1	0.0618	1.6	2.5
SLF1255T-680M-N	68	20	1	0.0832	1.3	2.2
SLF1255T-101M-N	100	20	1	0.117	1.1	1.8
SLF1255T-151M-N	150	20	1	0.19	0.88	1.4
SLF1255T-221M-N	220	20	1	0.27	0.72	1.2
SLF1255T-331M-N	330	20	1	0.41	0.59	1
SLF1255T-471M-N	470	20	1	0.52	0.49	0.88
SLF1255T-681M-N	680	20	1	0.76	0.43	0.73
SLF1255T-102M-N	1000	20	1	1.12	0.34	0.6
SLF1255T-152M-N	1500	20	1	1.73	0.29	0.48

- Tolerance: M = \pm 20%
- Isat: Value obtained when DC current flows and the initial value of inductance has fallen by 10%
- Itemp current: Value obtained when current flows and the temperature has risen to 30°C
- Test equipment Inductance: HP4284A LF impedance analyzer or equivalent (Test frequency: 1KHz/0.5V)
- RDC:CH502BC

Electrical Characteristics

Part Number	Inductance (μ H)	Tolerance (\pm %)	Test Frequency (KHz)	DC Resistance (Ω \pm 20%)	Isat (A)	Itemp (A) Max
SLF1265T-2R0T-N	2	30	1	0.0117	10	6.2
SLF1265T-4R2T-N	4.2	30	1	0.015	7.3	5.5
SLF1265T-7R0T-N	7	30	1	0.0177	5.7	5
SLF1265T-100M-N	10	20	1	0.0202	5	4.8
SLF1265T-150M-N	15	20	1	0.0237	4.2	4.4
SLF1265T-220M-N	22	20	1	0.0316	3.5	3.8
SLF1265T-330M-N	33	20	1	0.0406	2.8	3.4
SLF1265T-470M-N	47	20	1	0.0578	2.4	2.8
SLF1265T-680M-N	68	20	1	0.0787	2	2.4
SLF1265T-101M-N	100	20	1	0.123	1.6	1.9
SLF1265T-221M-N	220	20	1	0.273	1	1.2

- Tolerance: M = \pm 20%
- Isat: Value obtained when DC current flows and the initial value of inductance has fallen by 10%
- Itemp current: Value obtained when current flows and the temperature has risen to 40°C
- Test equipment Inductance: HP4284A LF impedance analyzer or equivalent (Test frequency: 1KHz/0.5V)
- RDC:CH502BC

Electrical Characteristics

Part Number	Inductance (μ H)	Tolerance (\pm %)	Test Frequency (KHz)	DC Resistance ($\Omega \pm 20\%$)	Isat (A)	Itemp (A) Max
SLF1275T-1R2T-N	1.2	30	1	0.0069	13	8.2
SLF1275T-2R7T-N	2.7	30	1	0.0094	10	7
SLF1275T-3R9T-N	3.9	30	1	0.0104	9	6.7
SLF1275T-5R6T-N	5.6	30	1	0.0116	7.8	6.3
SLF1275T-6R8T-N	6.8	30	1	0.0131	7.2	5.9
SLF1275T-100M-N	10	20	1	0.0156	5.5	5.4
SLF1275T-150M-N	15	20	1	0.0184	4.7	5
SLF1275T-220M-N	22	20	1	0.0263	4	4
SLF1275T-330M-N	33	20	1	0.0395	3.2	3.4
SLF1275T-470M-N	47	20	1	0.0528	2.7	3
SLF1275T-680M-N	68	20	1	0.0778	2	2.4
SLF1275T-101M-N	100	20	1	0.1250	1.9	1.9
SLF1275T-151M-N	150	20	1	0.1750	1.5	1.6
SLF1275T-221M-N	220	20	1	0.2580	1.3	1.3

- Tolerance: M = $\pm 20\%$
- Isat: Value obtained when DC current flows and the initial value of inductance has fallen by 10%
- Itemp current: Value obtained when current flows and the temperature has risen to 40°C
- Test equipment Inductance: HP4284A LF impedance analyzer or equivalent (Test frequency: 1KHz/0.5V)
- RDC: CH502BC

Packaging Specifications

Tape Dimensions

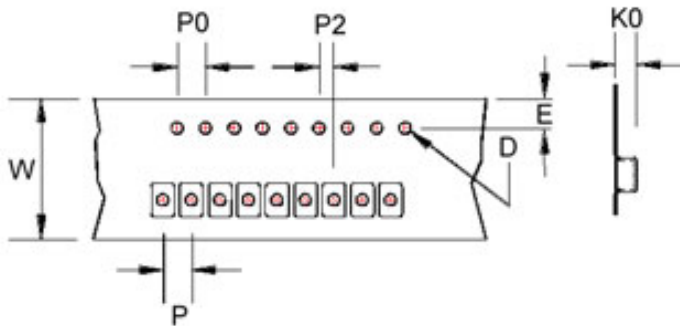

Tape Material

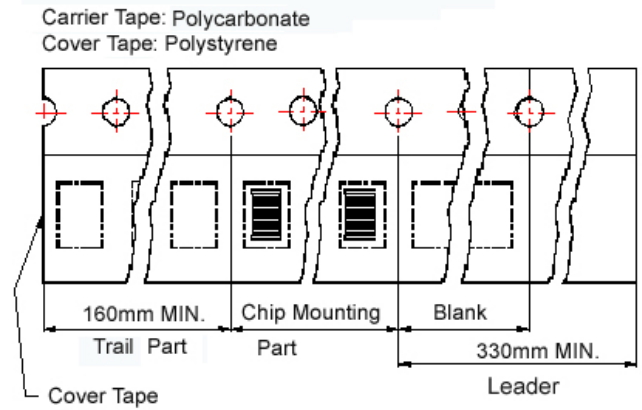

Reel Dimensions

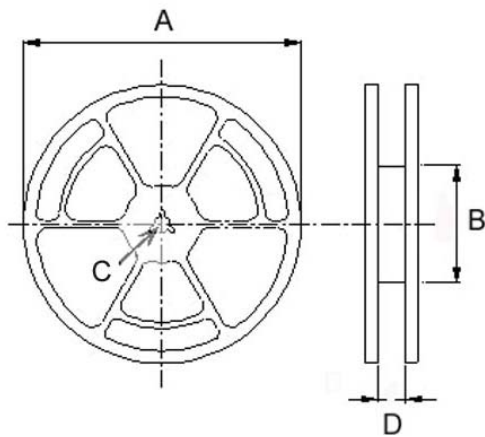

Dimensions in mm

TYPE	Tape Dimensions							Reel Dimensions				Quantity PCS / REEL
	K0	D	E	W	P	P0	P2	A	B	C	D	
SLF 0628	3.4	1.55	1.75	16	12	4	2	330	100	13	17.4	1000
SLF 0728	3.2	1.55	1.75	16	12	4	2	330	100	13	17.4	1000
SLF 0730	3.5	1.55	1.75	16	12	4	2	330	100	13	17.4	1000
SLF 0732	3.5	1.55	1.75	16	12	4	2	330	100	13	17.4	1000
SLF 0745	4.8	1.55	1.75	16	12	4	2	330	100	13	17.4	1000
SLF 0755	5.7	1.55	1.75	16	12	4	2	330	100	13	17.4	900
SLF 1045	5.0	1.55	1.75	24	16	4	2	330	100	13	24.4	500
SLF 1055	5.0	1.55	1.75	24	16	4	2	330	100	13	24.4	500
SLF 1255	6.0	1.55	1.75	24	16	4	2	330	100	13	24.4	500
SLF 1265	7.0	1.55	1.75	24	16	4	2	330	100	13	24.4	500
SLF 1275	8.2	1.55	1.75	24	16	4	2	330	100	13	24.4	350