

High Voltage Fast Switching NPN Power Transistor

3DG3020A1

FEATURES

- Low Switch dissipation
- Low Reverse Current
- Excellent High temperature characteristics
- High reliability

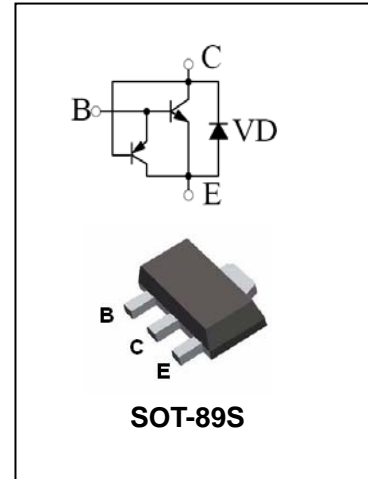

APPLICATIONS

- Mainly used for compact electronic energy saving lamps, electronic charger, computer auxiliary power supply, power

Switch circuit, this is the core component of electronic products.

ORDERING INFORMATION

Type No.	Marking	Package Code
3DG3020A1	3020A1	SOT-89S

MAXIMUM RATING @ Ta=25°C unless otherwise specified

Symbol	Parameter	Value	Units
V _{CBO}	Collector-Base Voltage	800	V
V _{CEO}	Collector-Emitter Voltage	450	V
V _{EBO}	Emitter-Base Voltage	9	V
I _C	Collector Current -Continuous	1.5	A
P _C	Collector Dissipation	0.8	W
T _j	Junction Temperature	150	°C
T _{stg}	Storage Temperature	-55 to +150	°C

High Voltage Fast Switching NPN Power Transistor

3DG3020A1

ELECTRICAL CHARACTERISTICS @ Ta=25°C unless otherwise specified

Parameter	Symbol	Test conditions	MIN	TYP	MAX	UNIT
Collector-base breakdown voltage	$V_{(BR)CBO}$	$I_C=0.1mA, I_E=0$	800			V
Collector-emitter breakdown voltage	$V_{(BR)CEO}$	$I_C=1mA, I_B=0$	450			V
Emitter-base breakdown voltage	$V_{(BR)EBO}$	$I_E=0.1mA, I_C=0$	9			V
Collector cut-off current	I_{CBO}	$V_{CB}=800V, I_E=0$			0.1	mA
Collector cut-off current	I_{CEO}	$V_{CB}=450V, I_B=0$			0.1	mA
Emitter cut-off current	I_{EBO}	$V_{EB}=9V, I_C=0$			0.1	mA
DC current gain	h_{FE}	$V_{CE}=5V, I_C=0.2A$	20		35	
Ratio	h_{FE1}/h_{FE2}	$h_{FE1}: V_{CE}=5V, I_C=5mA$ $h_{FE2}: V_{CE}=5V, I_C=0.2A$	0.75	0.9		
Collector-emitter saturation voltage	$V_{CE(sat)}$	$I_C=0.5A, I_B=0.1A$		0.4	0.8	V
Base-emitter saturation voltage	$V_{BE(sat)}$	$I_C=0.5A, I_B=0.1A$		1	1.5	V
storage time	t_s	UI9600, $I_C=0.1A$	2		5	μs
rise time	t_r				1	μs
fall time	t_f				1	μs
Transition frequency	f_T	$V_{CE}=10V, I_C=0.1A,$ $f=1MHz$	5			MHz

TYPICAL CHARACTERISTICS @ Ta=25°C unless otherwise specified

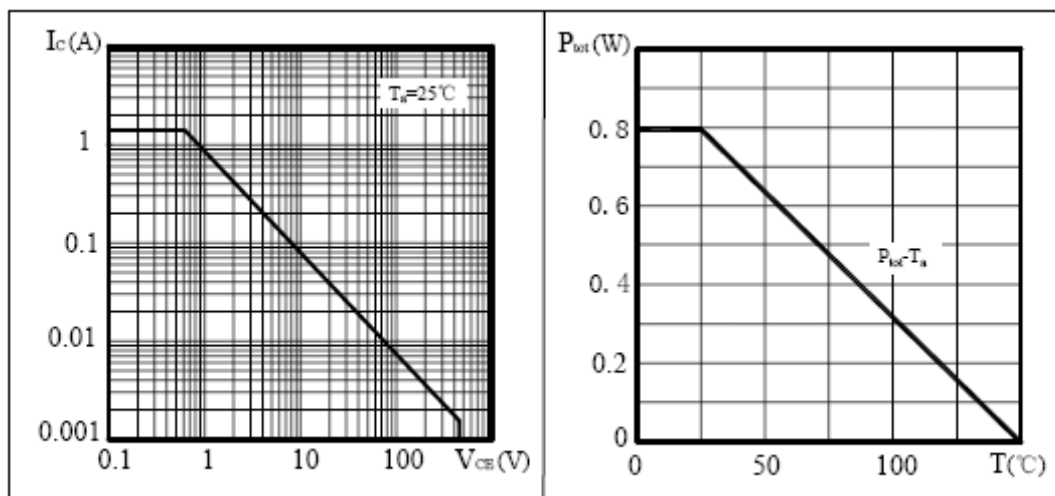

High Voltage Fast Switching NPN Power Transistor

3DG3020A1

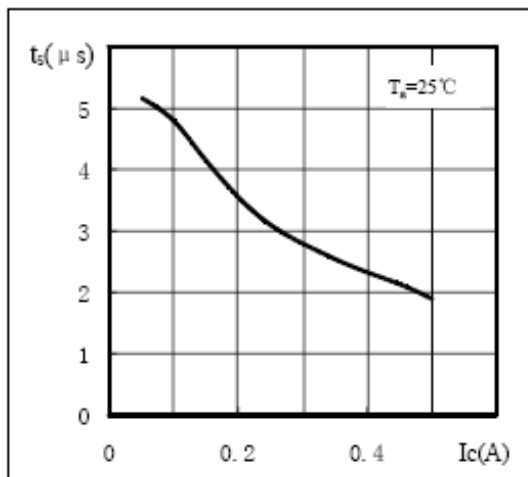
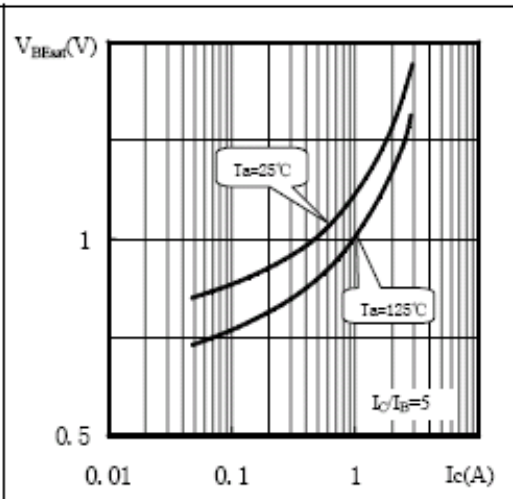
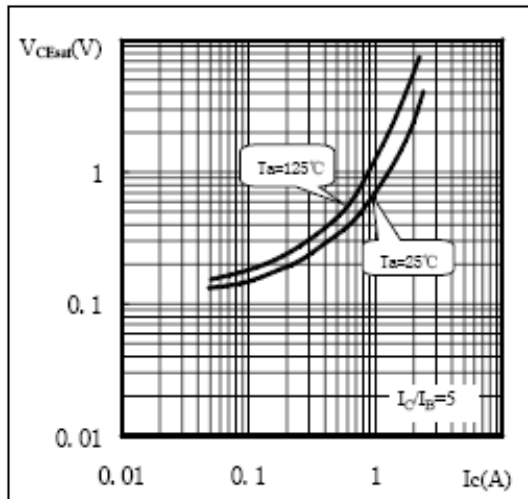
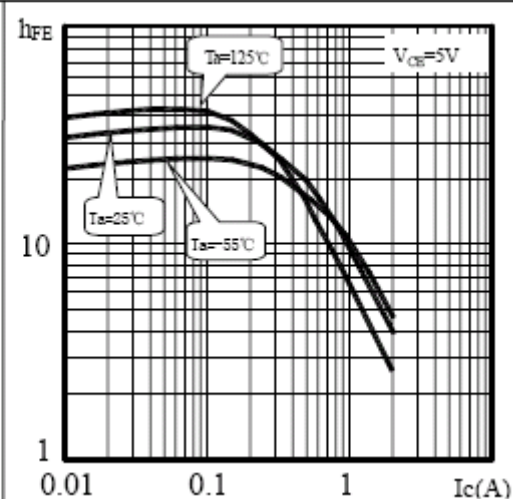
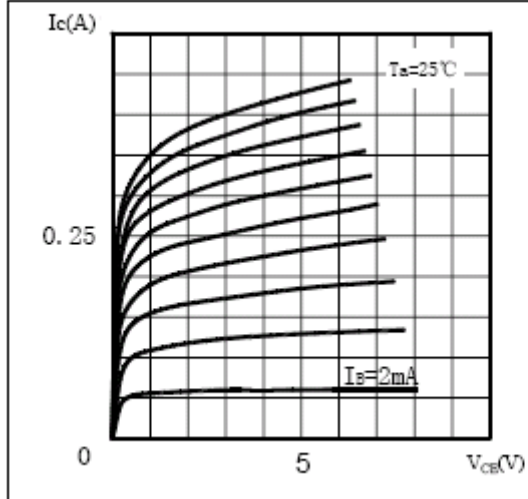



High Voltage Fast Switching NPN Power Transistor

3DG3020A1

PACKAGE OUTLINE

Plastic surface mounted package

SOT-89S

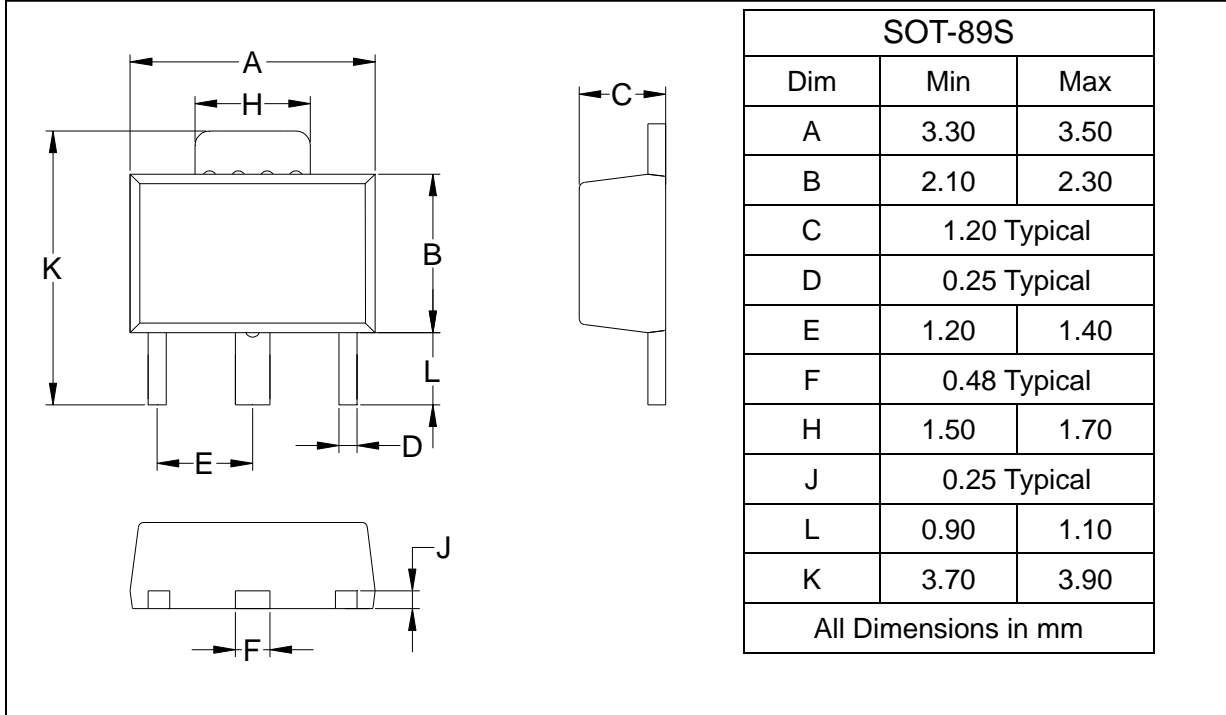

SOLDERING FOOTPRINT

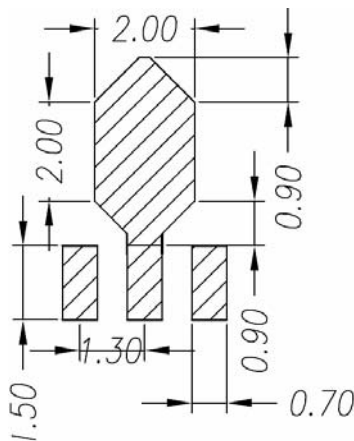

Unit:mm

PACKAGE INFORMATION

Device	Package	Shipping
3DG3020A1	SOT-89S	1000/Tape&Reel