

TOSHIBA MOS MEMORY PRODUCTS

TMM27512AD-17, TMM27512AD-20, TMM27512AD-25 TMM27512AD-200, TMM27512AD-250

DESCRIPTION

The TMM27512AD is a 65,536 words × 8 bits ultraviolet light erasable and electrically programmable read only memory.

For read operation, the TMM27512AD's access time is 170ns/200ns/250ns, and the TMM27512AD operates from a single 5-volt power supply and has low power standby mode which reduces the power dissipation without increasing access time. The standby mode is achieved by applying a TTL-high level signal to the \overline{CE} input.

For program operation, the programming is achieved by using the high speed programming mode. The TMM27512AD is fabricated with the N-channel silicon double layer gate MOS technology.

FEATURES

	-17	-20	-25	-200	-250
V _{CC}	5V±5%			5V±10%	
t _{ACC}	170ns	200ns	250ns	200ns	250ns
I _{CC2}	120mA			130mA	
I _{CC1}	35mA			40mA	

- Full static operation
- High speed programming mode I, II
- Inputs and outputs TTL compatible
- Pin compatible with i27512
- Standard 28 pin DIP cerdip package

BLOCK DIAGRAM

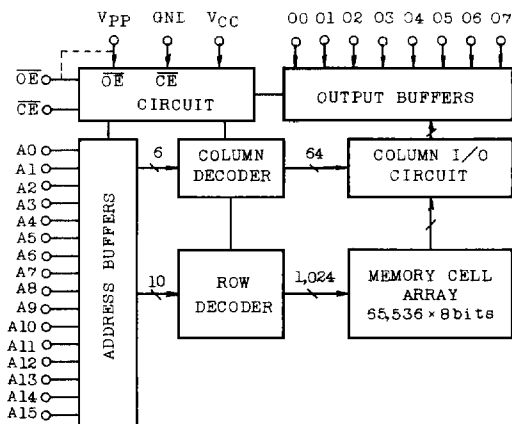

PIN CONNECTION

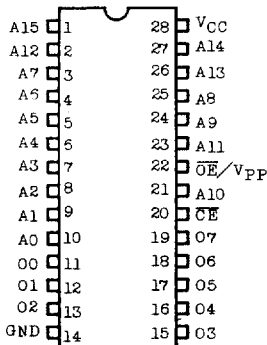

PIN NAMES

A0 ~ A15	Address Inputs
00 ~ 07	Outputs (Inputs)
\overline{CE}	Chip Enable Input
\overline{OE}/V_{PP}	Output Enable / Program Supply Input / Program Voltage
V _{CC}	Power Supply Voltage (+5V)
GND	Ground

MODE SELECTION

MODE	PIN	\overline{CE} (20)	\overline{OE}/V_{PP} (22)	V _{CC} (28)	00 ~ 07 (11 ~ 13, 15 ~ 19)	POWER
Read		L	L	5V	Data Out	Active
Output Deselect	*	H			High Impedance	
Standby		H	*		High Impedance	Standby
Program		L	V _{PP}	6V ¹⁾	Data In	Active
Program Inhibit		H	V _{PP}		High Impedance	
Program Verify		L	L	6.25V	Data Out	

*: H or L

1): HIGH SPEED PROGRAMMING MODE I

2): HIGH SPEED PROGRAMMING MODE II

TMM27512AD-17, TMM27512AD-20, TMM27512AD-25
TMM27512AD-200, TMM27512AD-250

MAXIMUM RATINGS

SYMBOL	ITEM	RATING	UNIT
V _{CC}	V _{CC} Power Supply Voltage	-0.6 ~ 7.0	V
V _{PP}	Program Supply Voltage	-0.6 ~ 14.0	V
V _{IN}	Input Voltage	-0.6 ~ 7.0	V
V _{I/O}	Input/Output Voltage	-0.6 ~ 7.0	V
P _D	Power Dissipation	1.5	W
T _{SOLDER}	Soldering Temperature · Time	260 · 10	°C · sec
T _{STG}	Storage Temperature	-65 ~ 125	°C
T _{OPR}	Operating Temperature	0 ~ 70	°C

READ OPERATION

DC AND AC RECOMMENDED OPERATING CONDITIONS

SYMBOL	PARAMETER	TMM27512AD-17/20/25	TMM27512AD-200/250
T _a	Operating Temperature	0 ~ 70°C	0 ~ 70°C
V _{CC}	V _{CC} Power Supply Voltage	5V±5%	5V±10%

DC AND OPERATING CHARACTERISTICS

SYMBOL	PARAMETER	CONDITION	MIN.	TYP.	MAX.	UNIT	
I _{LI}	Input Current	V _{IN} =0 ~ V _{CC}	-	-	±10	μA	
I _{LO}	Output Leakage Current	V _{OUT} =0.4 ~ V _{CC}	-	-	±10	μA	
I _{CC1}	Supply Current (Standby)	$\overline{CE}=V_{IH}$	-17/20/25	-	-	35	mA
			-200/250	-	-	40	
I _{CC2}	Supply Current (Active)	$\overline{CE}=V_{IL}$	-17/20/25	-	-	120	mA
			-200/250	-	-	130	
V _{IH}	Input High Voltage	-	2.0	-	V _{CC} +1.0	V	
V _{IL}	Input Low Voltage	-	-0.3	-	0.8	V	
V _{OH}	Output High Voltage	I _{OH} =-400μA	2.4	-	-	V	
V _{OL}	Output Low Voltage	I _{OL} =2.1mA	-	-	0.4	V	
I _{PP1}	V _{PP} Current	V _{PP} =0 ~ V _{CC} +0.6	-	-	±10	μA	

TMM27512AD-17, TMM27512AD-20, TMM27512AD-25 TMM27512AD-200, TMM27512AD-250

AC CHARACTERISTICS

SYMBOL	PARAMETER	TMM27512AD-17		TMM27512AD-20/200		TMM27512AD-25/250		UNIT
		MIN.	MAX.	MIN.	MAX.	MIN.	MAX.	
t_{ACC}	Address Access Time	-	170	-	200	-	250	ns
t_{CE}	\overline{CE} to Output Valid	-	170	-	200	-	250	ns
t_{OE}	\overline{OE} to Output Valid	-	70	-	70	-	100	ns
t_{DF1}	\overline{CE} to Output in High-Z	0	60	0	60	0	90	ns
t_{DF2}	\overline{OE} to Output in High-Z	0	60	0	60	0	90	ns
t_{OH}	Output Data Hold Time	0	-	0	-	0	-	ns

AC TEST CONDITIONS

- Output Load : 1 TTL Gate and $C_L=100pF$
- Input Pulse Rise and Fall Times : 10ns Max.
- Input Pulse Levels : 0.45V ~ 2.4V
- Timing Measurement Reference Level: Inputs 0.8V and 2.0V, Outputs 0.8V and 2.0V

CAPACITANCE * ($T_a=25^\circ C$, $f=1MHz$)

SYMBOL	PARAMETER	TEST CONDITION	MIN.	TYP.	MAX.	UNIT
C_{IN1}	Input Capacitance	$V_{IN}=0V$	-	4	6	pF
C_{IN2}	\overline{OE}/V_{pp} Input Capacitance	$V_{IN}=0V$	-	50	60	pF
C_{OUT}	Output Capacitance	$V_{OUT}=0V$	-	8	12	pF

* This parameter is periodically sampled and is not 100% tested.

TIMING WAVEFORMS (READ)

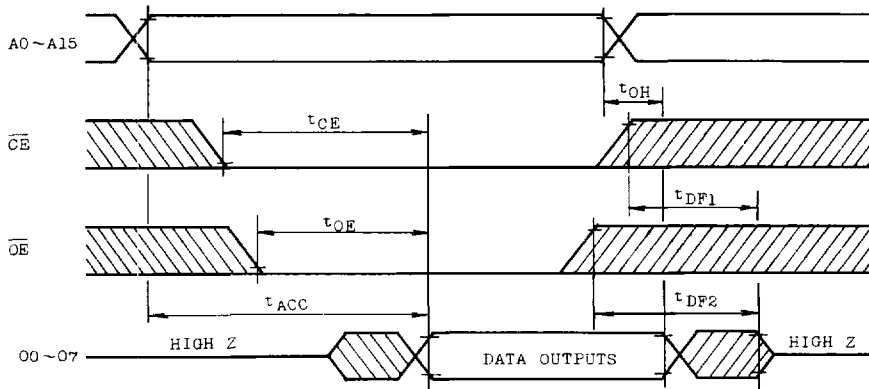

TMM27512AD-17, TMM27512AD-20, TMM27512AD-25 TMM27512AD-200, TMM27512AD-250

PROGRAM OPERATION (HIGH SPEED PROGRAMMING MODE I)

DC RECOMMENDED OPERATING CONDITIONS

SYMBOL	PARAMETER	MIN.	TYP.	MAX.	UNIT
V _{IH}	Input High Voltage	2.0	-	V _{CC} +1.0	V
V _{IL}	Input Low Voltage	-0.3	-	0.8	V
V _{CC}	V _{CC} Power Supply Voltage	5.75	6.0	6.25	V
V _{PP}	V _{PP} Power Supply Voltage	12.0	12.5	13.0	V

DC and OPERATING CHARACTERISTICS (T_a=25±5°C, V_{CC}=6V±0.25V, V_{PP}=12.5V±0.5V)

SYMBOL	PARAMETER	TEST CONDITION	MIN.	TYP.	MAX.	UNIT
I _{LI}	Input Current	V _{IN} =0 ~ V _{CC}	-	-	±10	μA
V _{OH}	Output High Voltage	I _{OH} =-400μA	2.4	-	-	V
V _{OL}	Output Low Voltage	I _{OL} =2.1mA	-	-	0.4	V
I _{CC}	V _{CC} Supply Current	-	-	-	130	mA
I _{PP2}	V _{PP} Supply Current	V _{PP} =13.0V	-	-	50	mA

AC PROGRAMMING CHARACTERISTICS (T_a=25±5°C, V_{CC}=6V±0.25V, V_{PP}=12.5V±0.5V)

SYMBOL	PARAMETER	TEST CONDITION	MIN.	TYP.	MAX.	UNIT
t _{AS}	Address Setup Time	-	2	-	-	μs
t _{AH}	Address Hold Time	-	2	-	-	μs
t _{OES}	\overline{OE}/V_{PP} Setup Time	-	2	-	-	μs
t _{OEH}	\overline{OE}/V_{PP} Hold Time	-	2	-	-	μs
t _{PRT}	\overline{OE}/V_{PP} Pulse Rise Time	-	50	-	-	ns
t _{DS}	Data Setup Time	-	2	-	-	μs
t _{DH}	Data Hold Time	-	2	-	-	μs
t _{VR}	\overline{OE}/V_{PP} Recovery Time	-	2	-	-	μs
t _{VCS}	V _{CC} Setup Time	-	2	-	-	μs
t _{PW}	Initial Program Pulse Width	$\overline{CE}=V_{IL}$, $\overline{OE}/V_{PP}=V_{PP}$	0.95	1.0	1.05	ms
t _{OPW}	Overprogram Pulse Width	Note 1	2.85	3.0	78.75	ms
t _{DV}	Data Valid from \overline{CE}	$\overline{OE}/V_{PP}=V_{IL}$	-	-	1	μs
t _{DF}	\overline{CE} to Output in High-Z	$\overline{OE}/V_{PP}=V_{IL}$	-	-	130	ns

AC TEST CONDITIONS

- Output Load : 1 TTL Gate and C_L (100pF)
- Input Pulse Rise and Fall Times : 10ns Max.
- Input Pulse Levels : 0.45V ~ 2.4V
- Timing Measurement Reference Level: Input 0.8V and 2.0V, Output 0.8V and 2.0V

Note 1: The length of the overprogram pulse may vary as a function of the counter value X.

TMM27512AD-17, TMM27512AD-20, TMM27512AD-25 TMM27512AD-200, TMM27512AD-250

PROGRAM OPERATION (HIGH SPEED PROGRAMMING MODE II)

DC RECOMMENDED OPERATING CONDITIONS

SYMBOL	PARAMETER	MIN.	TYP.	MAX.	UNIT
V _{IH}	Input High Voltage	2.0	-	V _{CC} +1.0	V
V _{IL}	Input Low Voltage	-0.3	-	0.8	V
V _{CC}	V _{CC} Power Supply Voltage	6.0	6.25	6.5	V
V _{PP}	V _{PP} Power Supply Voltage	12.5	12.75	13.0	V

DC and OPERATING CHARACTERISTICS (T_a=25±5°C, V_{CC}=6.25V±0.25V, V_{PP}=12.75V±0.25V)

SYMBOL	PARAMETER	TEST CONDITION	MIN.	TYP.	MAX.	UNIT
I _{LI}	Input Current	V _{IN} =0 ~ V _{CC}	-	-	±10	μA
V _{OH}	Output High Voltage	I _{OH} =-400μA	2.4	-	-	V
V _{OL}	Output Low Voltage	I _{OL} =2.1mA	-	-	0.4	V
I _{CC}	V _{CC} Supply Current	-	-	-	130	mA
I _{PP2}	V _{PP} Supply Current	V _{PP} =13.0V	-	-	50	mA

AC PROGRAMMING CHARACTERISTICS (T_a=25±5°C, V_{CC}=6.25V±0.25V, V_{PP}=12.75V±0.25V)

SYMBOL	PARAMETER	TEST CONDITION	MIN.	TYP.	MAX.	UNIT
t _{AS}	Address Setup Time	-	2	-	-	μs
t _{AH}	Address Hold Time	-	2	-	-	μs
t _{OES}	\overline{OE}/V_{PP} Setup Time	-	2	-	-	μs
t _{OEH}	\overline{OE}/V_{PP} Hold Time	-	2	-	-	μs
t _{PRT}	\overline{OE}/V_{PP} Pulse Rise Time	-	50	-	-	ns
t _{DS}	Data Setup Time	-	2	-	-	μs
t _{DH}	Data Hold Time	-	2	-	-	μs
t _{VR}	\overline{OE}/V_{PP} Recovery Time	-	2	-	-	μs
t _{VCS}	V _{CC} Setup Time	-	2	-	-	μs
t _{PW}	Program Pulse Width	$\overline{CE}=V_{IL}$, $\overline{OE}/V_{PP}=V_{PP}$	0.095	0.1	0.105	ms
t _{DV}	Data Valid from \overline{CE}	$\overline{OE}/V_{PP}=V_{IL}$	-	-	1	μs
t _{DF}	\overline{CE} to Output in High-Z	$\overline{OE}/V_{PP}=V_{IL}$	-	-	130	ns

AC TEST CONDITIONS

- Output Load : 1 TTL Gate and C_L (100pF)
- Input Pulse Rise and Fall Times : 10ns Max.
- Input Pulse Levels : 0.45V ~ 2.4V
- Timing Measurement Reference Level: Input 0.8V and 2.0V, Output 0.8V and 2.0V

TMM27512AD-17, TMM27512AD-20, TMM27512AD-25 TMM27512AD-200, TMM27512AD-250

TIMING WAVEFORMS (PROGRAM)

HIGH SPEED PROGRAMMING MODE I ($V_{CC}=6V\pm 0.25V$, $V_{PP}=12.5V\pm 0.5V$)

HIGH SPEED PROGRAMMING MODE II ($V_{CC}=6.25V\pm 0.25V$, $V_{PP}=12.75V\pm 0.25V$)

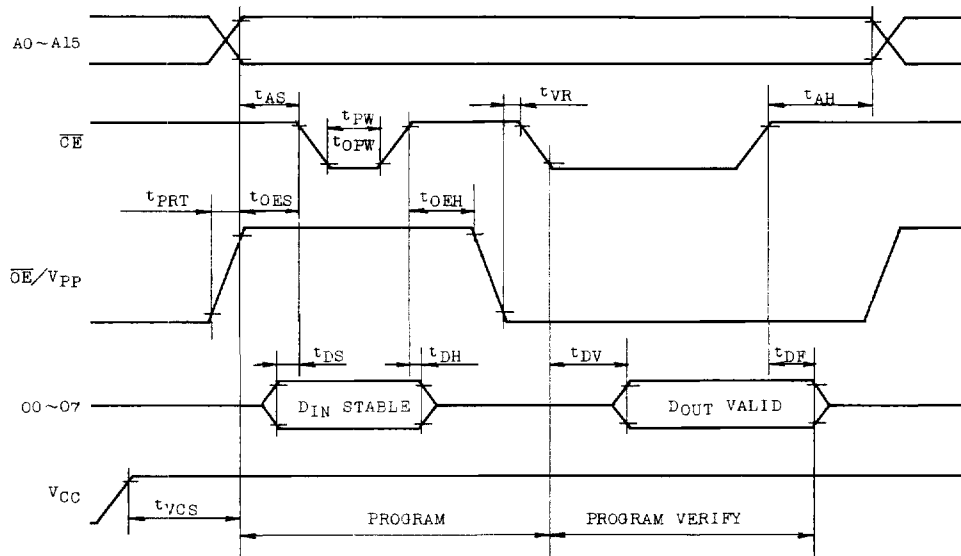

Note 1. V_{CC} must be applied simultaneously or before V_{PP} and cut off simultaneously or after V_{PP} .

2. Removing the device from socket and setting the device in socket with $V_{PP}=12.5\pm 0.5V$ or $V_{PP}=12.75\pm 0.25V$ may cause permanent damage to the device.

3. The V_{PP} supply voltage is permitted up to 14V for program operation. So the voltage over 14V should not be applied to the V_{PP} terminal. When the switching pulse voltage is applied to the V_{PP} terminal, the overshoot voltage of its pulse should not be exceeded 14V.

TMM27512AD-17, TMM27512AD-20, TMM27512AD-25 TMM27512AD-200, TMM27512AD-250

ERASURE CHARACTERISTICS

The TMM27512AD's erasure is achieved by applying shortwave ultraviolet light which has a wavelength of 2537Å (Angstroms) to the chip through the transparent window. Then integrated dose (ultraviolet light intensity [$\mu\text{w}/\text{cm}^2$] \times exposure time [sec.]) for erasure should be a minimum of 15 [$\text{w}\cdot\text{sec}/\text{cm}^2$].

When the Toshiba sterilizing lamp GL-15 is used and the device is exposed at a distance of 1cm from the lamp surface, the erasure will be achieved within 60 minutes. And using commercial lamps whose ultraviolet light intensity is a 12000 [$\mu\text{w}/\text{cm}^2$] will reduce the exposure time to about 20 minutes. (In this case, the integrated dose is 12000 [$\mu\text{w}/\text{cm}^2$] \times (20 \times 60) [sec] = 15 [$\text{w}\cdot\text{sec}/\text{cm}^2$].)

The TMM27512AD's erasure begins to occur when exposed to light with wavelength shorter than 4000Å. The sunlight and the fluorescent lamps will include 3000~4000Å wavelength components. Therefore when used under such lighting for extended periods of time, the opaque seals-Toshiba EPROM Protect Seal AC901-are available.

OPERATION INFORMATION

The TMM27512AD's six operation modes are listed in the following table. Mode selection can be achieved by applying TTL level signal to all inputs.

PIN NAMES (NUMBER)		$\overline{\text{CE}}$ (20)	$\overline{\text{OE}}/\text{V}_{\text{PP}}$ (22)	V_{CC} (28)	00~07 (11~13, 15~19)	POWER
Read Operation ($T_a=0 \sim 70^\circ\text{C}$)	Read	L	L	5V	Data Out	Active
	Output Deselect	*	H		High Impedance	
	Standby	H	*		High Impedance	
Program Operation ($T_a=25 \pm 5^\circ\text{C}$)	Program	L	V_{PP}	6V ¹⁾	Data In	Active
	Program Inhibit	H	V_{PP}	2)	High Impedance	
	Program Verify	L	L	6.25V	Data Out	

Note: H; V_{IH} , L; V_{IL} , *; V_{IH} or V_{IL}

1); HIGH SPEED PROGRAMMING MODE I
2); HIGH SPEED PROGRAMMING MODE II

READ MODE

The TMM27512AD has two control functions. The chip enable ($\overline{\text{CE}}$) controls the operation power and should be used for device selection.

The output enable ($\overline{\text{OE}}$) control the output buffers, independent of device selection. Assuming that $\overline{\text{CE}}=\overline{\text{OE}}=\text{V}_{\text{IL}}$, the output data is valid at the outputs after address access time from stabilizing of all addresses.

The $\overline{\text{CE}}$ to output valid (t_{CE}) is equal to the address access time (t_{ACC}).

Assuming that $\overline{\text{CE}}=\text{V}_{\text{IL}}$ and all addresses are valid, the output data is valid at the outputs after t_{OE} from the falling edge of $\overline{\text{OE}}$.

TMM27512AD-17, TMM27512AD-20, TMM27512AD-25 TMM27512AD-200, TMM27512AD-250

OUTPUT DESELECT MODE

Assuming that $\overline{CE}=V_{IH}$ or $\overline{OE}=V_{IH}$, the outputs will be in a high impedance state. So two or more TMM27512AD's can be connected together on a common bus line. When \overline{CE} is decoded for device selection, all deselected devices are in low power standby mode.

STANDBY MODE

The TMM27512AD has a low power standby mode controlled by the \overline{CE} signal. By applying a high level to the \overline{CE} input, the TMM27512AD is placed in the standby mode which reduce 70% of the operating current by applying TTL-high level and then the outputs are in a high impedance state, independent of the \overline{OE} inputs.

PROGRAM MODE

Initially, when received by customers, all bits of the TMM27512AD are in the "1" state which is erased state.

Therefore the program operation is to introduce "0's" data into the desired bit locations by electrically programming.

The TMM27512AD is in the programming mode when the \overline{OE}/V_{pp} input is at 12.5V or 12.75V and \overline{CE} is at TTL-Low level.

The TMM27512AD can be programmed any location at anytime either individually, sequentially, or at random.

PROGRAM VERIFY MODE

The verify mode is to check that desired data is correctly programmed on the programmed bits.

The verify is accomplished with \overline{OE}/V_{pp} at V_{IL} and \overline{CE} at V_{IL} .

PROGRAM INHIBIT MODE

Under the condition that the program voltage(12.5V or 12.75V) is applied to V_{pp} terminal, a TTL high level \overline{CE} input inhibits the TMM27512AD from being programmed.

Programming of two or more TMM27512AD's in parallel with different data is easily accomplished. That is, all inputs except for \overline{CE} may be commonly connected, and a TTL Low level program pulse is applied to the \overline{CE} of the desired device only and TTL high level signal is applied to the other devices.

TMM27512AD-17, TMM27512AD-20, TMM27512AD-25 TMM27512AD-200, TMM27512AD-250

HIGH SPEED PROGRAMMING MODE I

This high speed programming mode I is performed at $V_{CC}=6.0V$ and $\overline{OE}/V_{PP}=12.5V$.

The programming is achieved by applying a single TTL low level 1ms pulse to the \overline{CE} input after addresses and data are stable. Then the programmed data is verified by using Program Verify Mode.

If the programmed data is not correct, another program pulse of 1ms is applied and then the programmed data is verified. This should be repeated until the program operates correctly (max. 25 times).

After correctly programming the selected address, the additional program pulse with pulse width 3 times that needed for initial programming is applied.

When programming has been completed, the data in all addresses should be verified with $V_{CC}=5V$.

HIGH SPEED PROGRAMMING MODE II

The program time can be greatly decreased by using this high speed programming mode II.

This high speed programming mode II is performed at $V_{CC}=6.25V$ and $\overline{OE}/V_{PP}=12.75V$.

The programming is achieved by applying a single TTL low level 0.1ms pulse to the \overline{CE} input after addresses and data are stable. Then the programmed data is verified by using Program Verify Mode.

If the programmed data is not correct, another program pulse of 0.1ms is applied and then the programmed data is verified. This should be repeated until the program operates correctly (max. 25 times).

When programming has been completed, the data in all addresses should be verified with $V_{CC}=5V$.

**TMM27512AD-17, TMM27512AD-20, TMM27512AD-25
TMM27512AD-200, TMM27512AD-250**

HIGH SPEED PROGRAMMING MODE I FLOW CHART

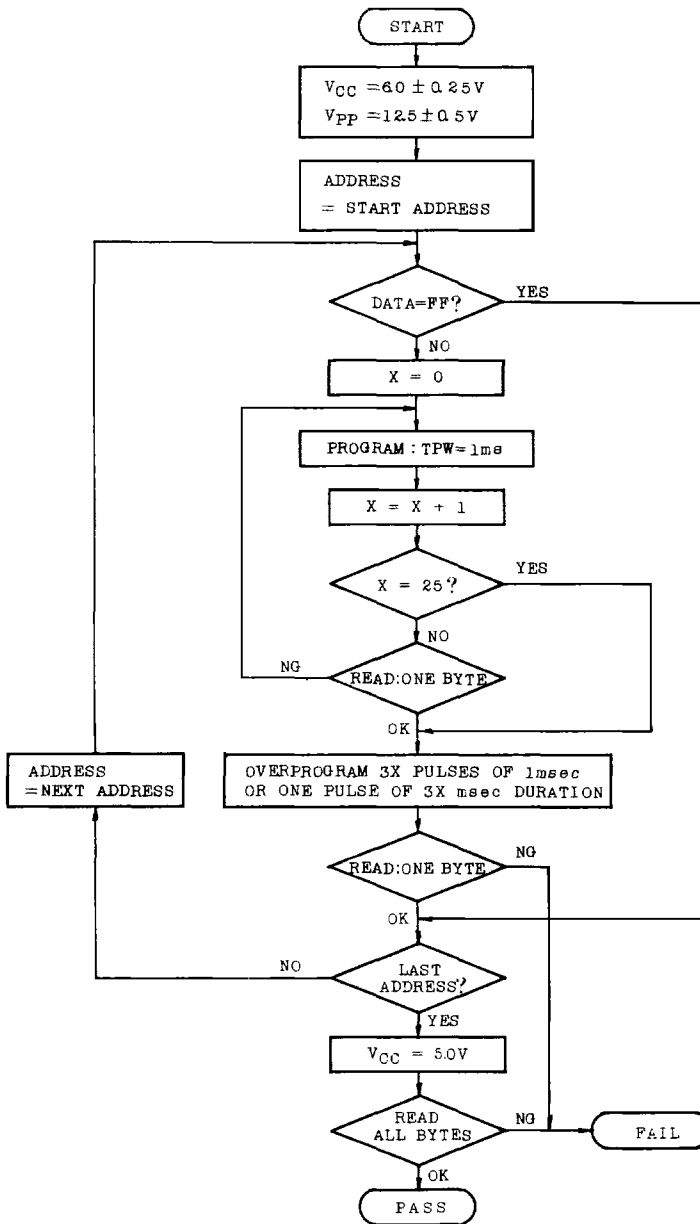

TMM27512AD-17, TMM27512AD-20, TMM27512AD-25 TMM27512AD-200, TMM27512AD-250

HIGH SPEED PROGRAMMING MODE II FLOW CHART

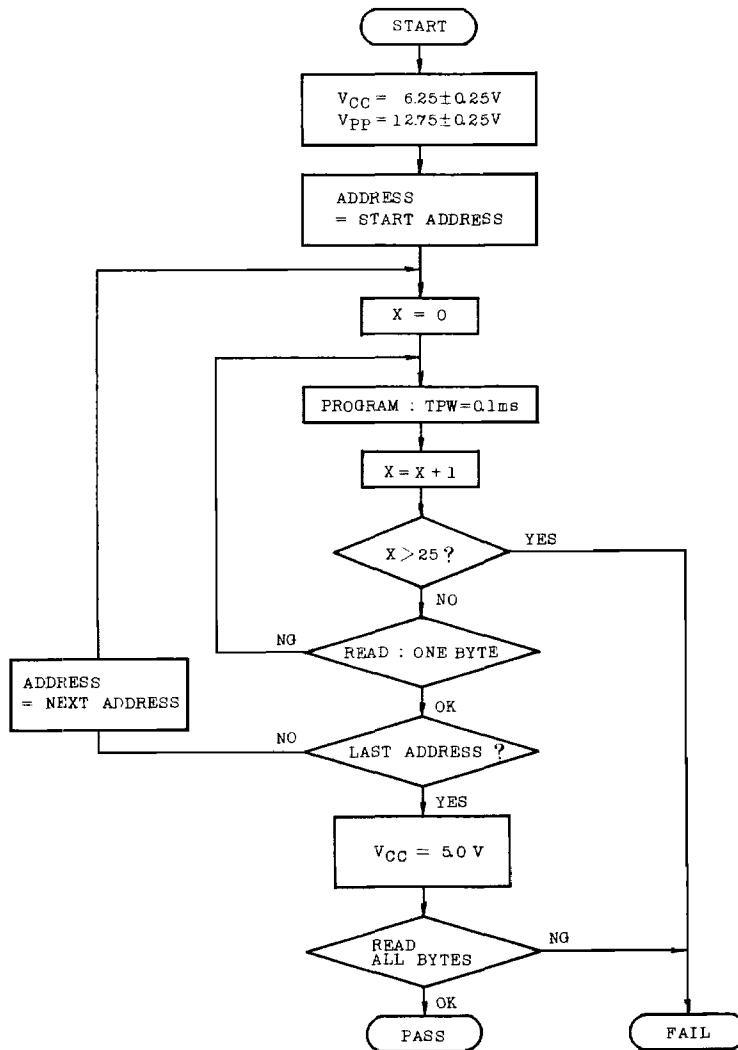

TMM27512AD-17, TMM27512AD-20, TMM27512AD-25
TMM27512AD-200, TMM27512AD-250

ELECTRIC SIGNATURE MODE

Electric signature mode allows to read out a code from TMM27512AD which identifies its manufacturer and device type.

The programming equipment may read out manufacturer code and device code from TMM27512AD by using this mode before program operation and automatically set program voltage (V_{pp}) and algorithm.

Electric Signature mode is set up when 12V is applied to address line A9 and the rest of address lines is set to V_{IL} in read operation. Data output in this conditions is manufacturer code. Device code is identified when address A0 is set to V_{IH} . These two codes possess an odd parity with the parity bit of MSB (07).

The following table shows electric signature of TMM27512AD.

SIGNATURE	PINS	A0	07	06	05	04	03	02	01	00	HEX.
		(10)	(19)	(18)	(17)	(16)	(15)	(13)	(12)	(11)	DATA
Manufacture code	V_{IL}	1	0	0	1	1	0	0	0	0	98
Device code	V_{IH}	0	0	0	1	0	1	0	1	1	15

Note: A9=12V±0.5V

A1 ~ A8, A10 ~ A15, \overline{CE} , $\overline{OE}=V_{IL}$

TMM27512AD-17, TMM27512AD-20, TMM27512AD-25 TMM27512AD-200, TMM27512AD-250

OUTLINE DRAWINGS

Unit in mm

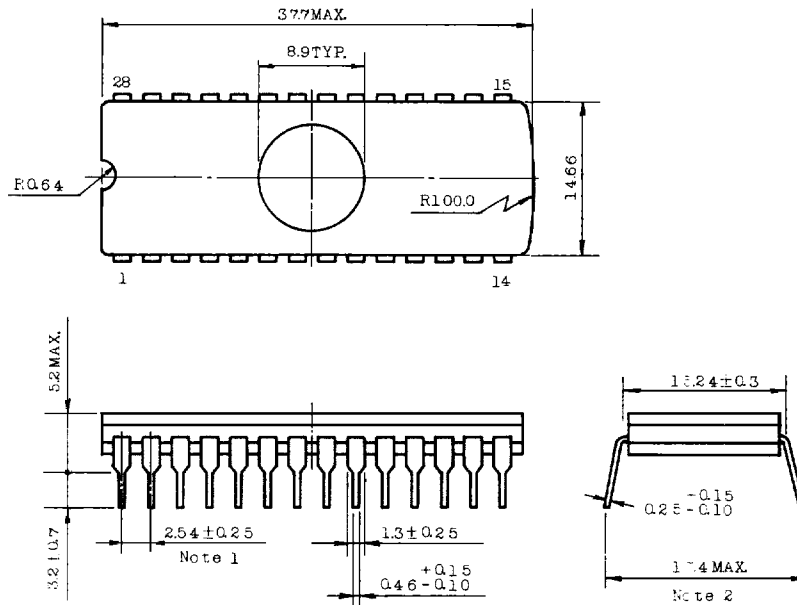

Note 1. Each lead pitch is 2.54mm. All leads are located within 0.25mm of their true longitudinal position with respect No.1 and No.28 leads.

2. This value is measured at the end of leads.

3. All dimensions are in millimeters.