



# SPE0584

## Ultra Low Capacitance 4 -Line ESD Protection Array

### DESCRIPTION

The SPE0584 is 4-channel very low capacitance ESD transient voltage suppressor which provides a very high level of protection for sensitive electronic components that may be subjected to electrostatic discharge. It is particularly well-suited to protect systems with high speed communication lines from ESD, EFT, and lightning.

The SPE0584 consists of two low capacitance steering diodes and a TVS diode in SOT-23-6L package. Each channel of SPE0584 could safely dissipate ESD strikes of  $\pm 15\text{kV}$  air discharge as well as  $\pm 8\text{kV}$  contact discharge, meeting the requirement of the IEC 61000-4-2 international standard. Using the MIL-STD-883 (Method 3015) specification for Human Body Model (HBM) ESD, the device provides protection for contact discharges to greater than  $\pm 15\text{kV}$ .

### APPLICATIONS

- ◆ Cellular Handsets and Accessories
- ◆ Cordless Phone
- ◆ PDA
- ◆ Notebooks and Handhelds
- ◆ Portable Instrumentation
- ◆ Digital Cameras
- ◆ MP3 Player High Definition Multi-Media Interface Protection
- ◆ USB 2.0 Power and Data Line
- ◆ Monitors and Notebook Computers
- ◆ HDSL, IDSL Secondary IC Side Protection
- ◆ 10/100/1000 Ethernet

### FEATURES

- ◆ Transient protection for data lines to

IEC 61000-4-2 (ESD)  
 $\pm 15\text{kV}$  (air)  
 $\pm 8\text{kV}$  (contact)

IEC 61000-4-4 (EFT)  
 40A (5/50ns)

- ◆ Protects five bidirectional I/O lines
- ◆ Working voltage: 5V
- ◆ Low leakage current
- ◆ Low operating and clamping voltages
- ◆ Low capacitance: 0.35 pF typical

### PIN CONFIGURATION ( SOT-23-6L )

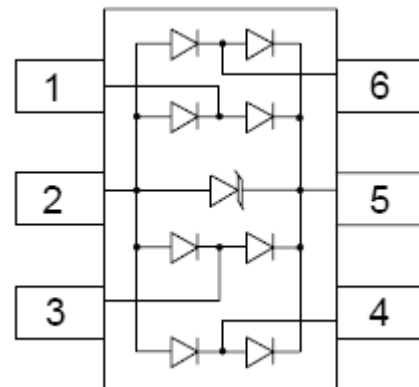

### PART MARKING

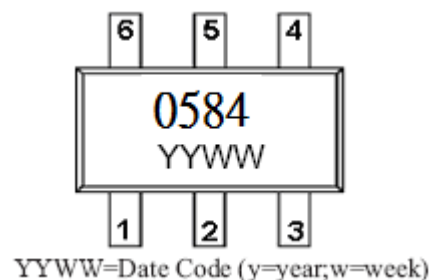



# SPE0584

## Ultra Low Capacitance 4-Line ESD Protection Array

### ORDERING INFORMATION

Part Number	Package	Part Marking
SPE0584S26RGB	SOT-23-6L	0584

YYWW = Date Code ( YY : 00~99 ; WW : 01~53)

※ SPE0584S26RGB : Tape Reel ; Pb – Free ; Halogen – Free

### ABSOLUTE MAXIMUM RATINGS

(TA=25°C Unless otherwise noted)

Parameter	Symbol	Typical	Unit
Peak Pulse Power ( tp = 8/20 μs )	Ppk	100	W
Maximum Peak Pulse Current ( tp = 8/20 μs )	Ipp	4	A
ESD per IEC 61000 – 4 – 2 (Air )	Vpp	±15	KV
ESD per IEC 61000 – 4 – 2 (Contact )	Vpp	±8	KV
Operating Junction Temperature	Tj	-55 ~ 125	°C
Storage Temperature Range	TSTG	-55 ~ 150	°C
Lead Soldering Temperature	TL	260 ( 10sec )	°C

### ELECTRICAL CHARACTERISTICS

(TA=25°C Unless otherwise noted)

Parameter	Symbol	Conditions	Min.	Typ	Max.	Unit
Reverse Stand – Off Voltage	VRWM				5	V
Forward Voltage @ IF	VF	IF = 15mA			1.15	V
Reverse Breakdown Voltage	VBR	It = 1mA	6.0	7.0		V
Reverse Leakage Current	IR	VRWM = 5V , T=25°C			1	μA
Clamping Voltage	VC	Ipp = 1A , tp = 8/20 μs			15	V
Junction Capacitance	Cj	VR = 0V , f = 1MHz Any I/O pin to Ground			0.8	pF
		VR = 0V , f = 1MHz Between I/O pins			0.35	



# SPE0584

## Ultra Low Capacitance 4-Line ESD Protection Array

### TYPICAL CHARACTERISTICS

Non-Repetitive Peak Pulse Power vs. Pulse Time

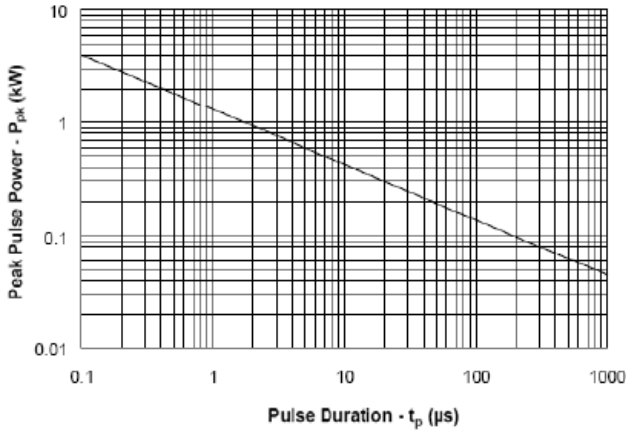

Power Derating Curve

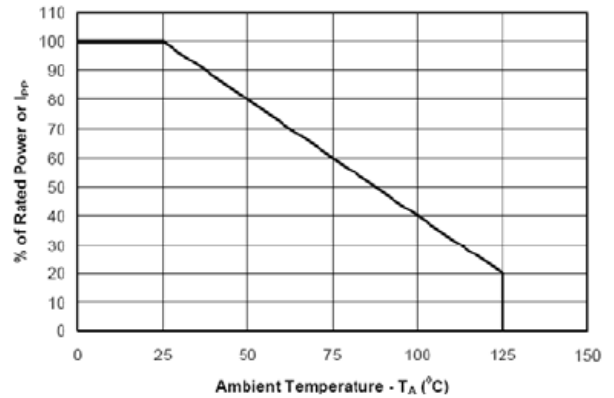

Clamping Voltage vs. Peak Pulse Current

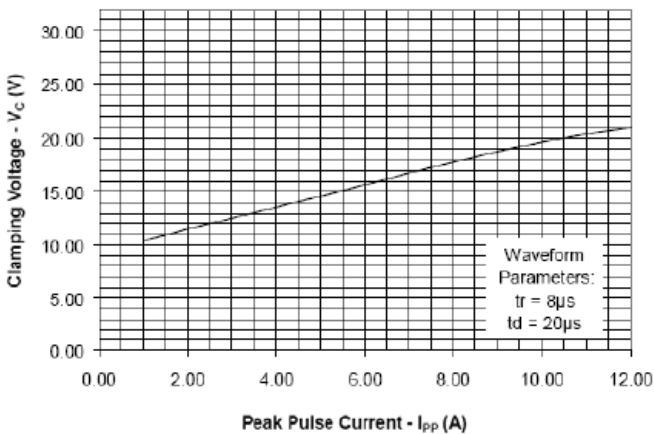

Forward Voltage vs. Forward Current

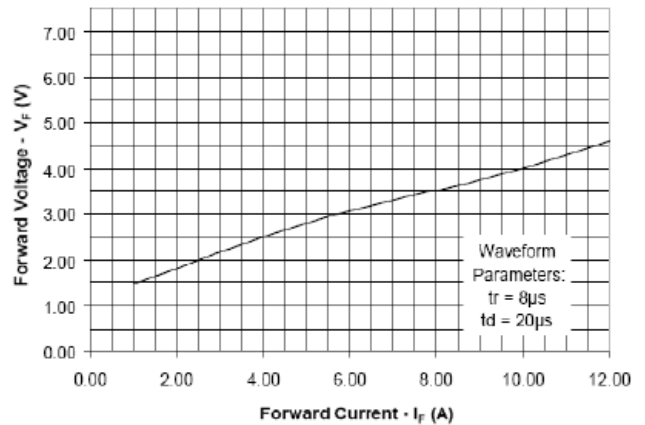



# SPE0584

## Ultra Low Capacitance 4-Line ESD Protection Array

### APPLICATION NOTE

#### SPE0584 Device Connection for Protection of Four Data Lines

This device is designed to protect data lines by clamping them to a fixed reference. When the voltage on the protected line exceeds the reference voltage the steering diodes are forward biased, conducting the transient current away from the sensitive circuitry. Data lines are connected at pins 1, 3, 4 and 6. Pin 2 should be connected directly to a ground plane. The path length is kept as short as possible to minimize parasitic inductance. The positive reference is connected at pin 5. The options for connecting the positive reference are as follows:

1. To protect data lines and the power line, connect pin 5 directly to the positive supply rail (VCC). In this configuration the data lines are referenced to the supply voltage. The internal TVS diode prevents over-voltage on the supply rail.
2. In applications where the supply rail does not exit the system, the internal TVS may be used as the reference. In this case, pin 5 is not connected. The steering diodes will begin to conduct when the voltage on the protected line exceeds the working voltage of the TVS (plus one diode drop).
3. In applications where complete supply isolation is desired, the internal TVS is again used as the reference and VCC is connected to one of the I/O inputs. An example of this configuration is the protection of a SIM port. The Clock, Reset, I/O, and VCC lines are connected at pins 1, 3, 4, and 6. Pin 2 is connected to ground and pin 5 is not connected.

**Data Line and Power Supply Protection Using Vcc as reference**

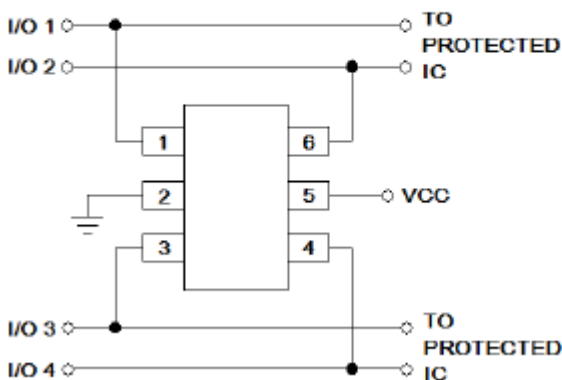

**Data Line Protection Using Internal TVS Diode as reference**

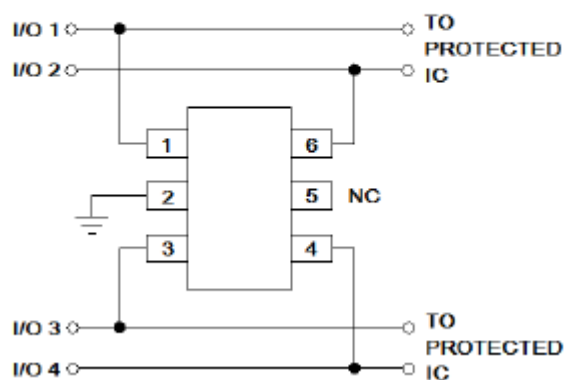



# SPE0584

## Ultra Low Capacitance 4-Line ESD Protection Array

### SOT-23-6L PACKAGE OUTLINE

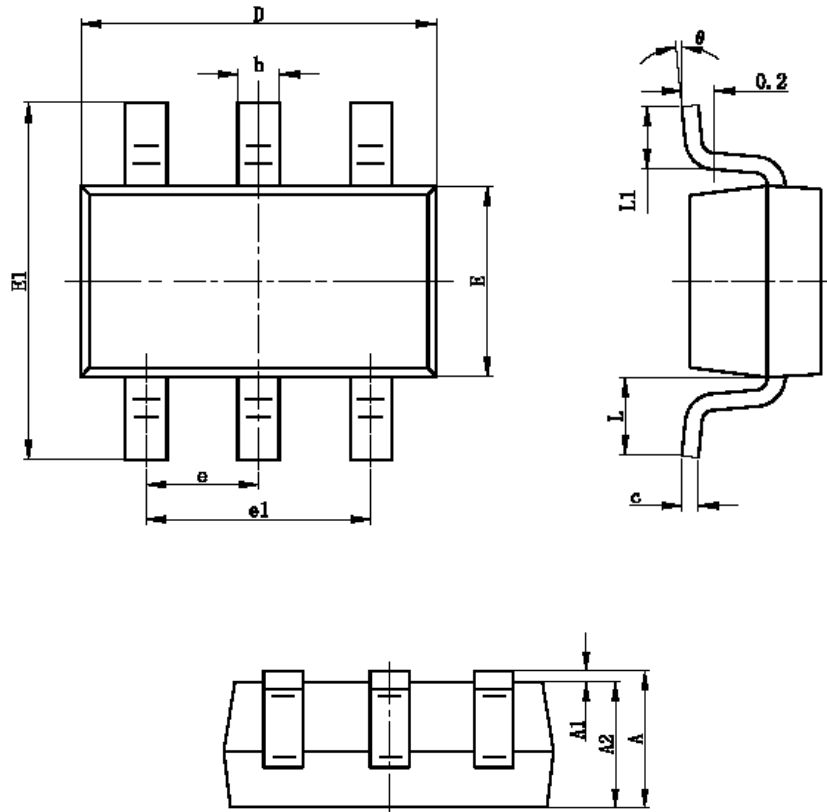

Symbol	Dimensions In Millimeters		Dimensions In Inches	
	Min	Max	Min	Max
A	1.050	1.250	0.041	0.049
A1	0.000	0.100	0.000	0.004
A2	1.050	1.150	0.041	0.045
b	0.300	0.400	0.012	0.016
c	0.100	0.200	0.004	0.008
D	2.820	3.020	0.111	0.119
E	1.500	1.700	0.059	0.067
E1	2.650	2.950	0.104	0.116
e	0.950TYP		0.037TYP	
e1	1.800	2.000	0.071	0.079
L	0.700REF		0.028REF	
L1	0.300	0.600	0.012	0.024
θ	0°	8°	0°	8°



# SPE0584

## Ultra Low Capacitance 4-Line ESD Protection Array

---

Information provided is alleged to be exact and consistent. SYNC Power Corporation presumes no responsibility for the penalties of use of such information or for any violation of patents or other rights of third parties which may result from its use. No license is granted by allegation or otherwise under any patent or patent rights of SYNC Power Corporation. Conditions mentioned in this publication are subject to change without notice. This publication surpasses and replaces all information previously supplied. SYNC Power Corporation products are not authorized for use as critical components in life support devices or systems without express written approval of SYNC Power Corporation.

©The SYNC Power logo is a registered trademark of SYNC Power Corporation

©2004 SYNC Power Corporation – Printed in Taiwan – All Rights Reserved

SYNC Power Corporation

7F-2, No.3-1, Park Street

NanKang District (NKSP), Taipei, Taiwan, 115, R.O.C

Phone: 886-2-2655-8178

Fax: 886-2-2655-8468

©<http://www.syncpower.com>