

## SPECIFICATION

Part No. : GLA.01

Product Name : 2.5dBi 1575.42MHz GPS Loop Antenna

Feature : Low profile SMT antenna  
High performance magnetic field antenna  
RoHS Compliant



Antenna



Antenna on EVB



## 1. Introduction

Taoglas have developed a unique ceramic miniature loop antenna series for GPS applications. At 5.0\*3.0\*0.5mm, the GLA.01 GPS Loop antenna is a miniature edge mounted antenna, designed for small space requirements. The radiation pattern is more omni-directional than traditional patch antennas. The GLA loop antenna series show at least three times the efficiency of traditional linear polarized 1575.42MHz MHz antennas. Efficiencies of 40% to 90% are achievable. Peak gain of 2.5dBi places this antenna gain performance within the range of a much larger 15mm to 18mm patch antenna.

Mechanically, the GLA.01 at only 0.5mm in height has a very low profile, and with a footprint of 6.0 x 5.5mm needs less space on the Board, it does require clearance of 6.0 x 5.5mm. Based on the loop effect this antenna works best when placed on the centre of the edge of the board, but can still work better than traditional linear polarized chip antennas even when placed at corners as substitute.

The GLA.01 is delivered on tape and reel and now allows M2M customers to use an omni-directional antenna in devices where orientation of the product is unknown.

### Applications

- \*Navigation or position tracking systems
- \*Hand-held devices when GPS function is needed, e.g., smart phone. PDA,

## 2. Specification

ELECTRICAL	
Centre Frequency	1575.42MHz ± 2MHz
VSWR	2 : 1 max
Polarization	Linear
Bandwidth	50MHz (-10dB return loss)
Peak Gain	2.5dBi typ.
Efficiency	83% typ.
Impedance	50 Ω
MECHANICAL	
Dimensions	5.0 x 3.0 x 0.5mm
Material	Ceramic
ENVIRONMENTAL	
Operation Temperature	-40°C to 85°C
Storage Temperature	-40°C to 105°C
Temperature Coefficient (τf)	0 ± 20 ppm @-20°C to +80°C
Recommended Reel Storage Condition	5°C to 40°C Relative Humidity 20% to 70%

\* Electrical properties are measured with the antenna properly mounted on EVB of 80 x 40mm.

### 3.S11 Property

#### 3.1. Return Loss

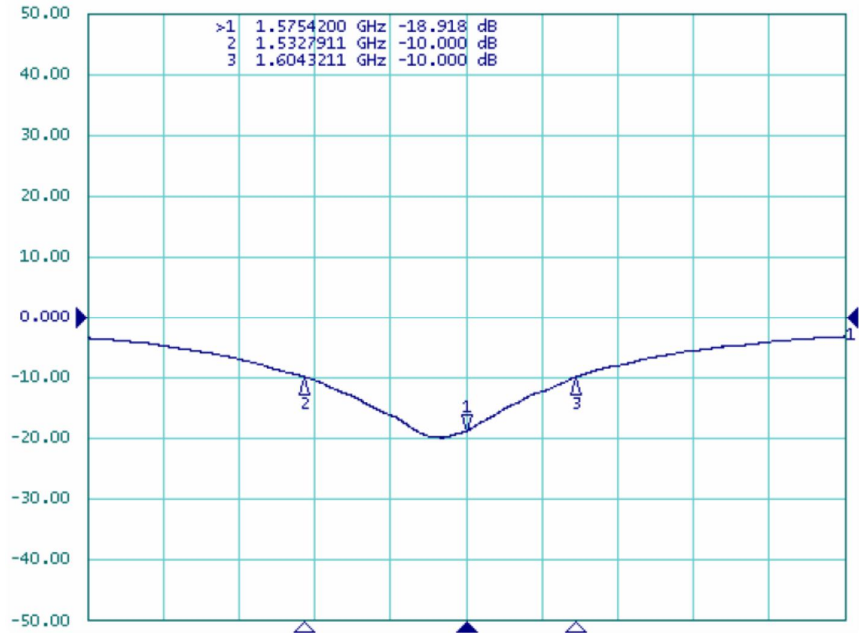

### 3.2. Impedance

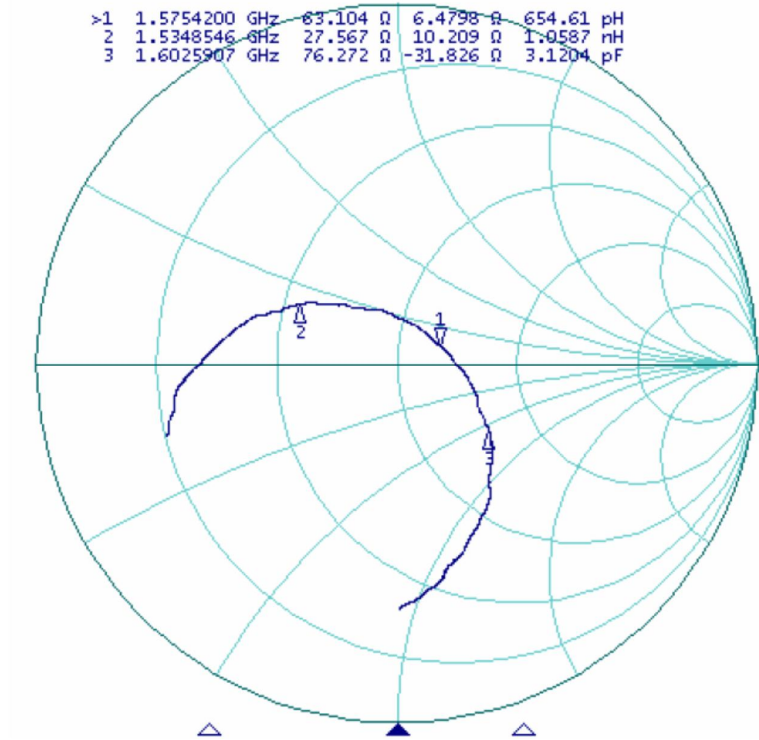

### 4. 2D Radiation Property @ 1575.42MHz

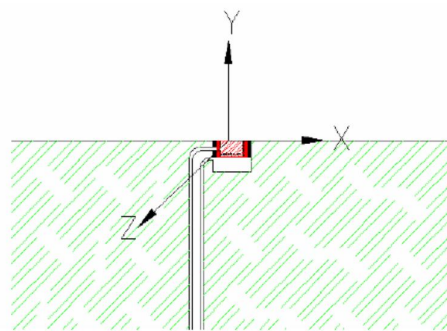

### Gain Table

Plane	XZ	YZ	XY
Peak gain	2.9	2.4	0.3
Average Gain	-2.9	-0.1	-6.2

### 4.1. XY Plane Radiation

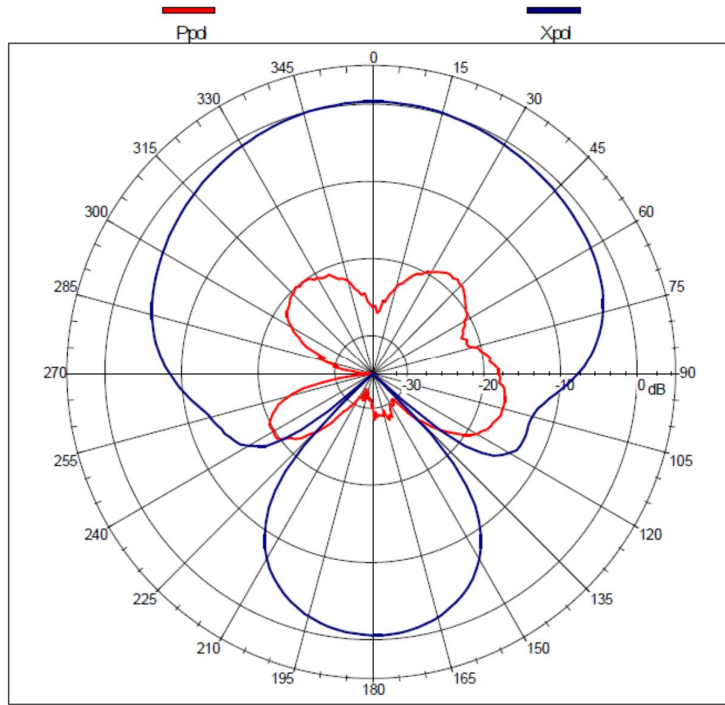

- Ppd – Vertical Polarization
- Xpd – Horizontal Polarization

## 4.2. XZ Plane Radiation

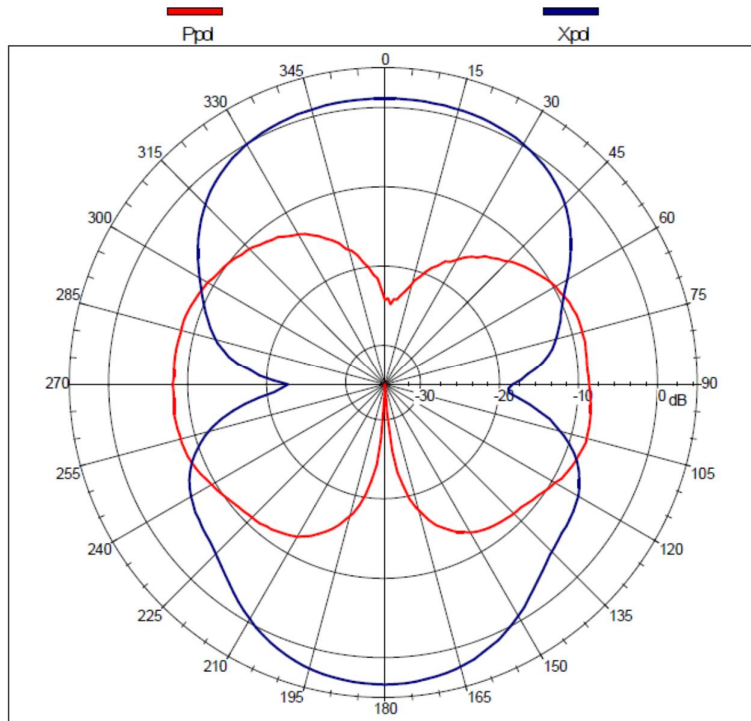

### 4.3. YZ Plane Radiation

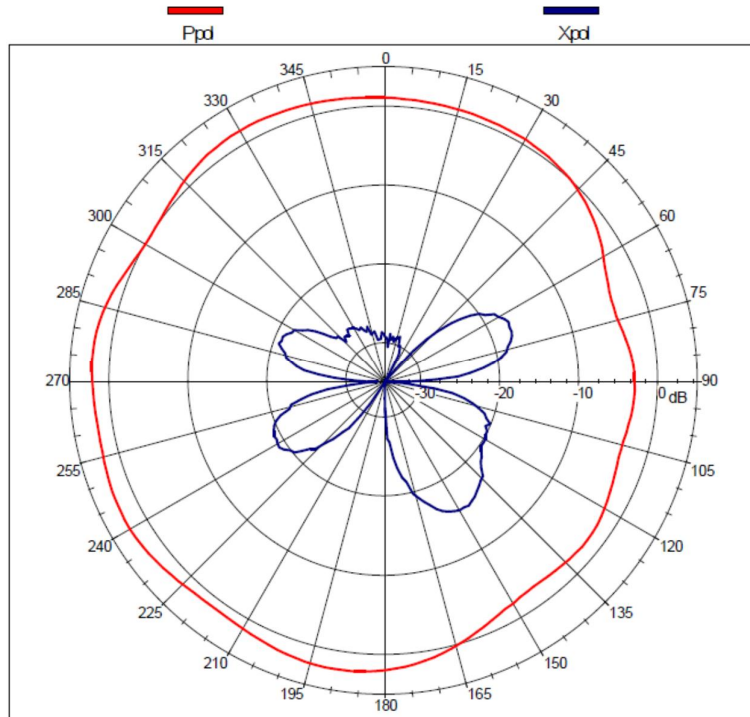



## 5. 3D Gain Pattern of GLA.01 on Different Ground

### 5.1. 80 \* 40mm EVB

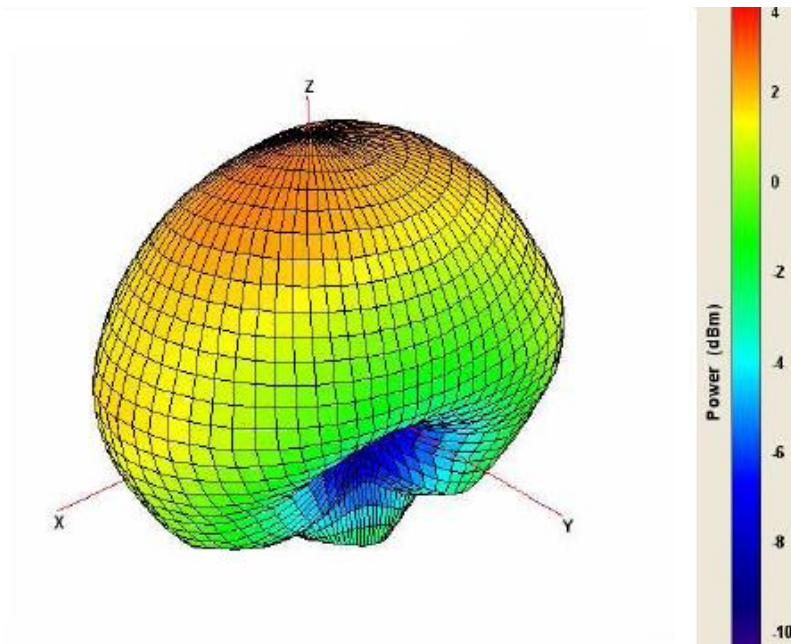
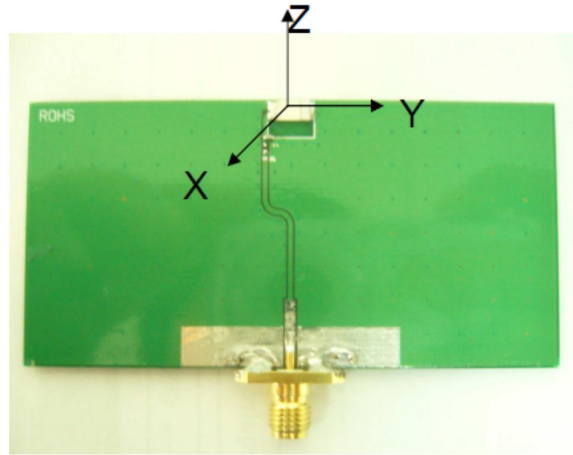

Frequency(MHz)	1560	1565	1570	1575	1580	1585	1590
Efficiency (%)	82.8	83.8	83.0	83.1	83.6	83.0	82.0
Gain (dBi)	2.7	2.8	2.8	2.8	2.8	2.7	2.7
Average Gain (dB)	-0.8	-0.8	-0.8	-0.8	-0.8	-0.8	-0.9

## 5.2. Centre Top of 50 x 100mm PCB

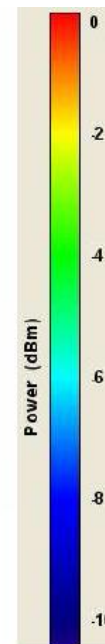
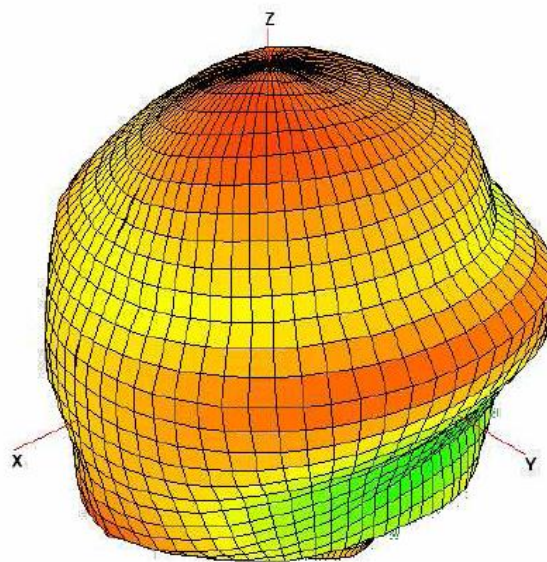
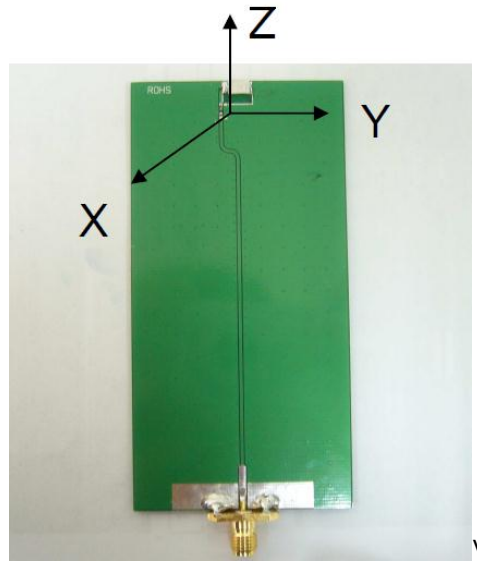

Frequency(MHz)	1560	1565	1570	1575	1580	1585	1590
Efficiency (%)	40.2	47.8	53.9	58.0	58.1	53.8	47.0
Peak Gain (dBi)	-2.5	-1.8	-1.2	-0.9	-0.9	-1.2	-1.8
Average Gain (dB)	-4.0	-3.2	-2.7	-2.4	-2.4	-2.7	-3.3

### 5.3. Top Left of 50 x 100mm PCB

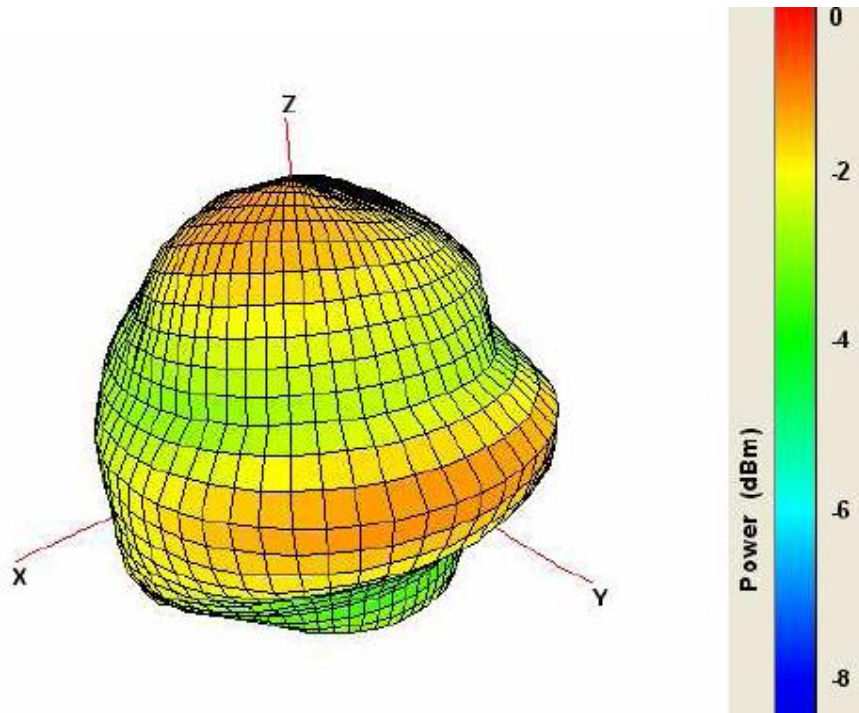
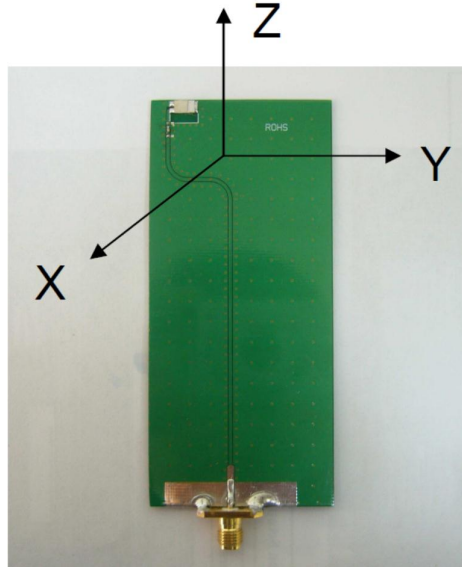

Frequency(MHz)	1560	1565	1570	1575	1580	1585	1590
Efficiency (%)	50.8	58.5	63.9	67.0	66.8	62.6	56.0
Gain (dBi)	-1.6	-1.0	-0.6	-0.3	-0.3	-0.6	-1.1
Average Gain (dB)	-2.9	-2.3	-1.9	-1.7	-1.8	-2.0	-2.5

## 6. Mechanical Drawing

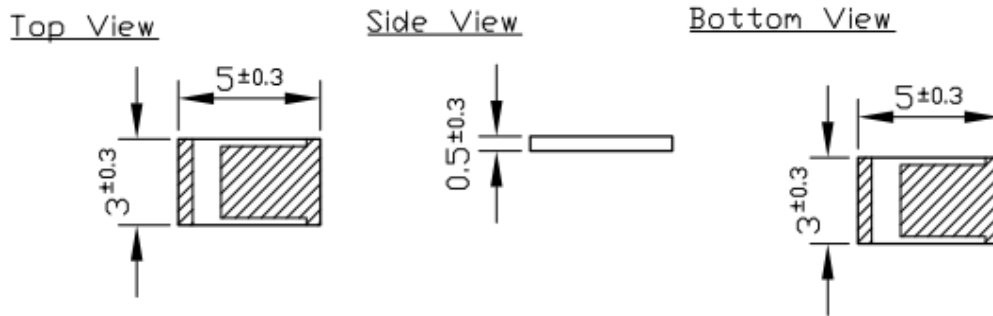

**GLA.01 on EVB**

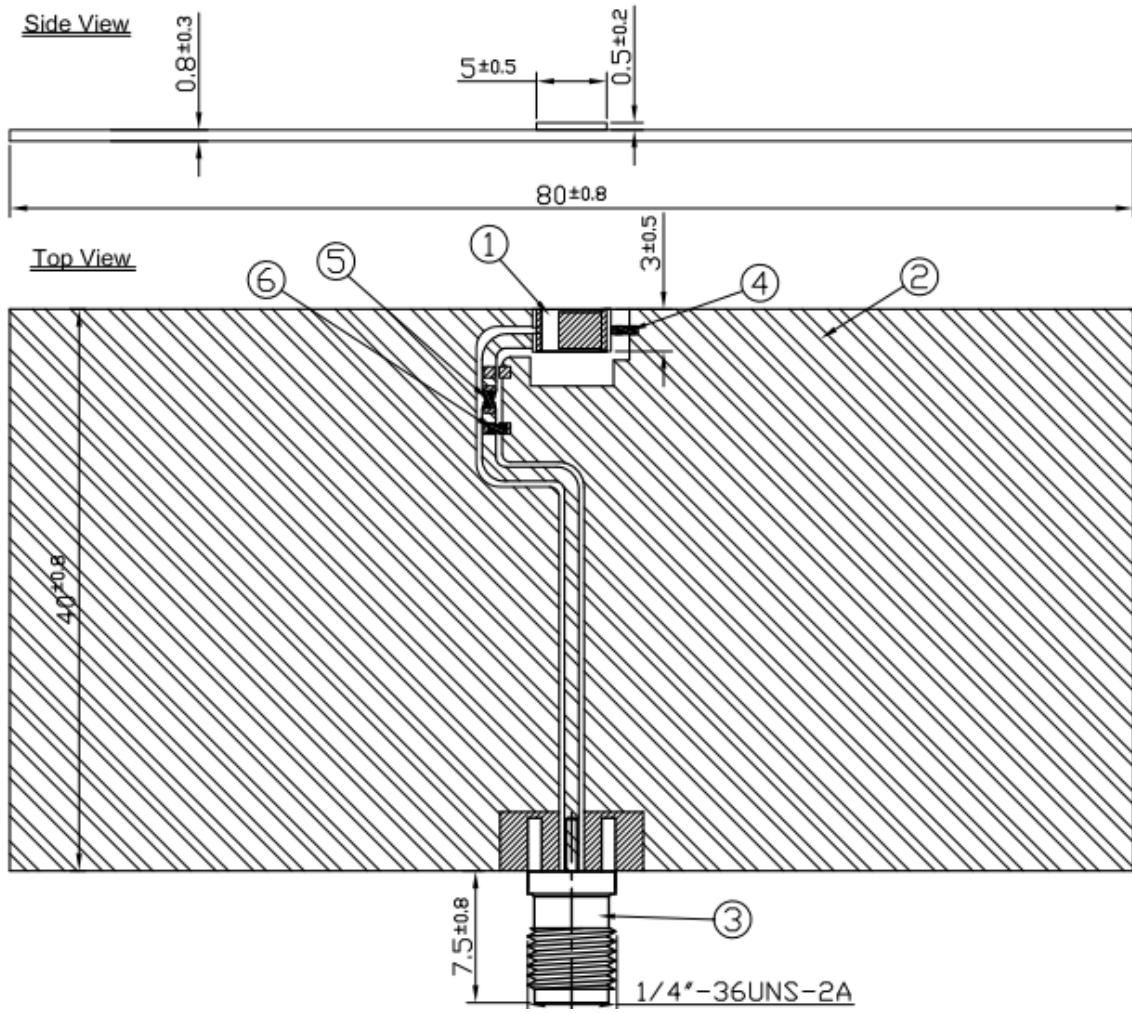

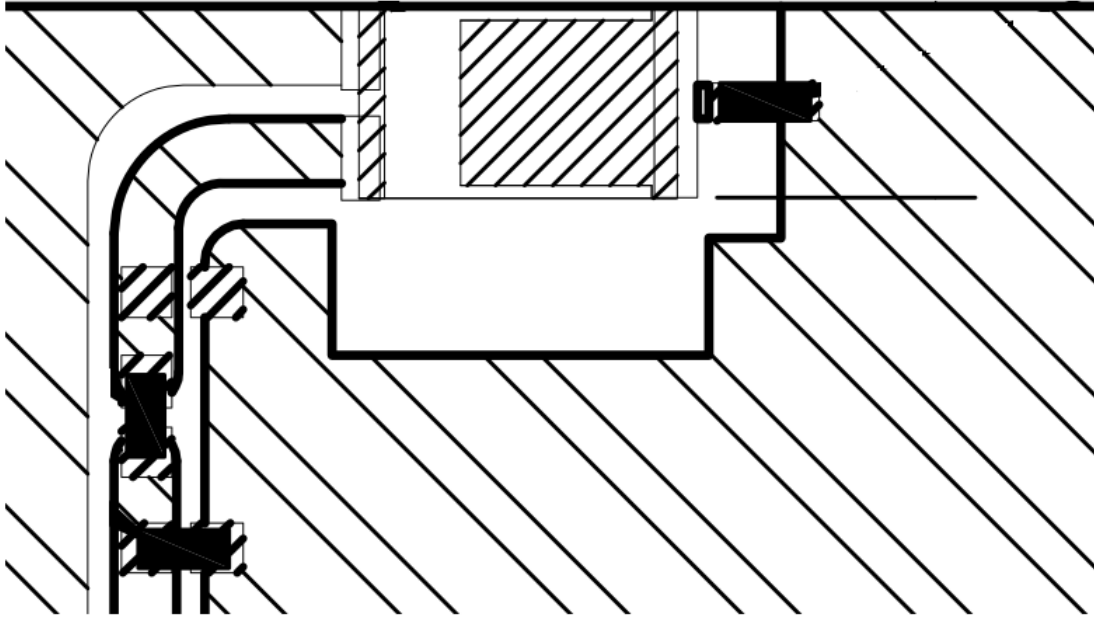

Close up on EVB Pictured with antenna facing up on component side of evaluation board

## 7. Antenna Layout Guide

### 7.1. Antenna Position

GLA.01 should be mounted at the edge (preferably longer than 50mm) of the PCB. Mounting antenna at the centre of the PCB edge and keep the ground area around the antenna as symmetric as possible tend to achieve higher antenna radiation efficiency. At least 5mm away from surrounding parts is required for the antenna to work.

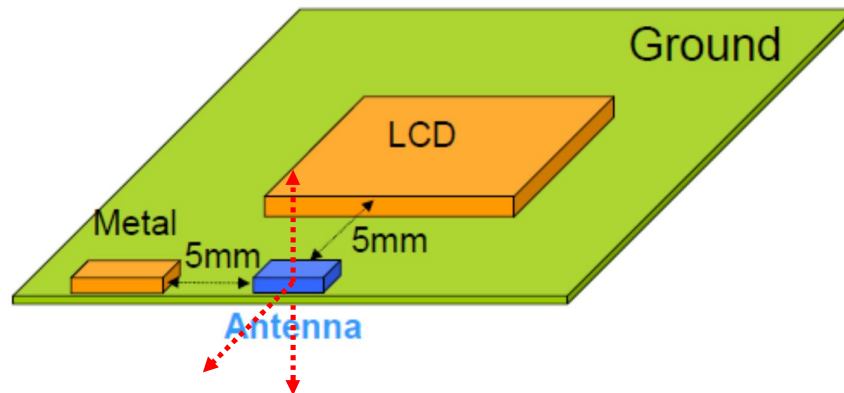

Note that GLA.01 has no orientation. It has the same performance when mounting it left side right or bottom side up. No metal, including coppers on PCB and components, is allowed in the top side, bottom side and board side of the antenna, as indicated by red arrows. If GLA.01 cannot be mounted right at the edge, please make sure that there is board size clearance, i.e. no metal between GLA.01 and PCB edge.

## 7.2. PCB Layout

Footprint of GLA.01 (grey marking areas) is as shown below. Both pads indicated with "G" should be connected to the ground directly. All layers need to have the clearance for GLA.01 to function correctly.

The pink dots in the diagram are vias. Via around the ground edges and all across the ground are recommended as they can keep all ground layers well connected together and have the same reference voltage everywhere in the system.

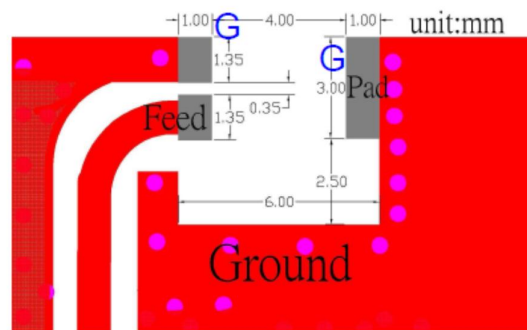

Foot Print  
FR4 PCB 0.8t

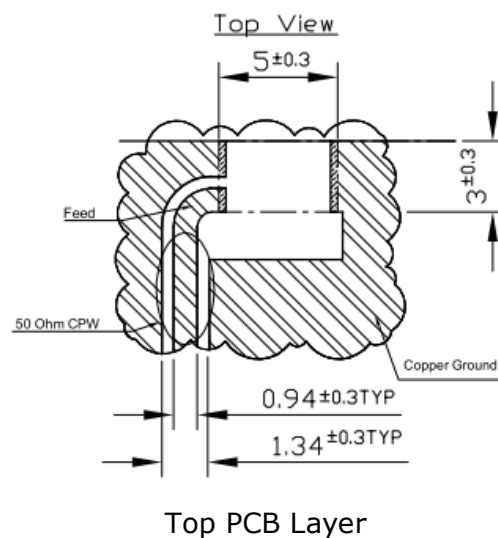



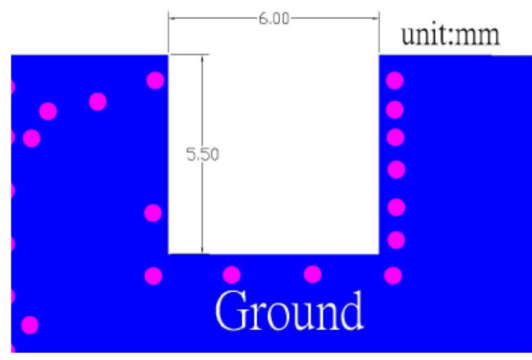

Back View

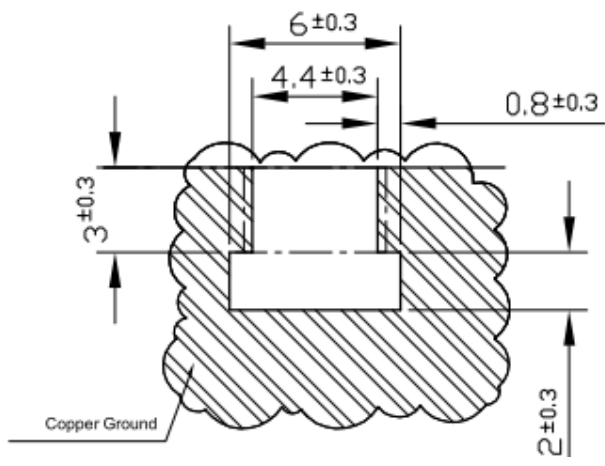

Bottom PCB Layer

The feed and the adjacent ground connection with GLA.01 may look like creating a short circuit. But in terms of RF signal, GLA.01 is guiding the electric current to flow in a loop and back to the starting point to create radiation.

### 7.3. Matching Circuit

It is a good idea to reserve footprints for matching component in case they are needed later. The matching components should be 1~2mm away from GLA.01.

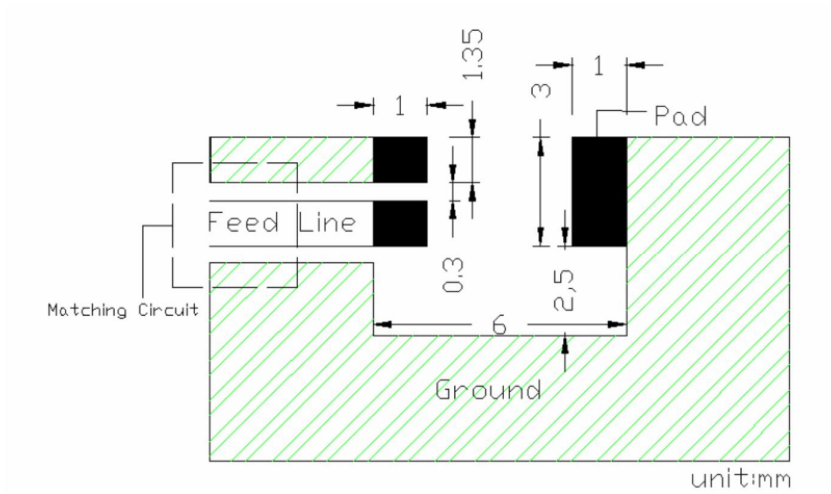

Matching circuit position

The most common matching arrangement is the pi matching as shown below. We have 2.2pF capacitor for Component 3 and 0Ohm resistor for Component 2 on EVB.

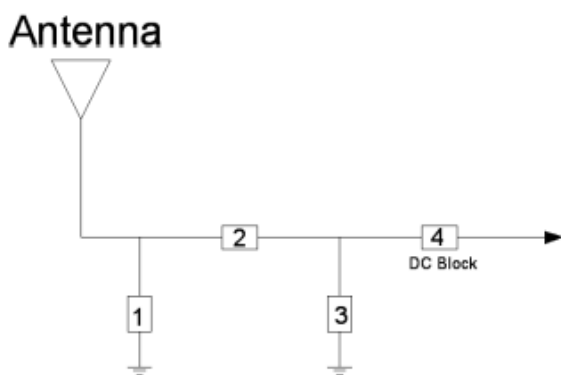

System Matching Circuit Component		
Location	Description	Vendor
1	N/A	-
2	0Ω	(0402)
3	2.2pF	TDK(0402)
4	22pF	TDK(0402)
Fine tuning element	8pF	TDK(0402)

### 7.4. Recommended Reflow Profile

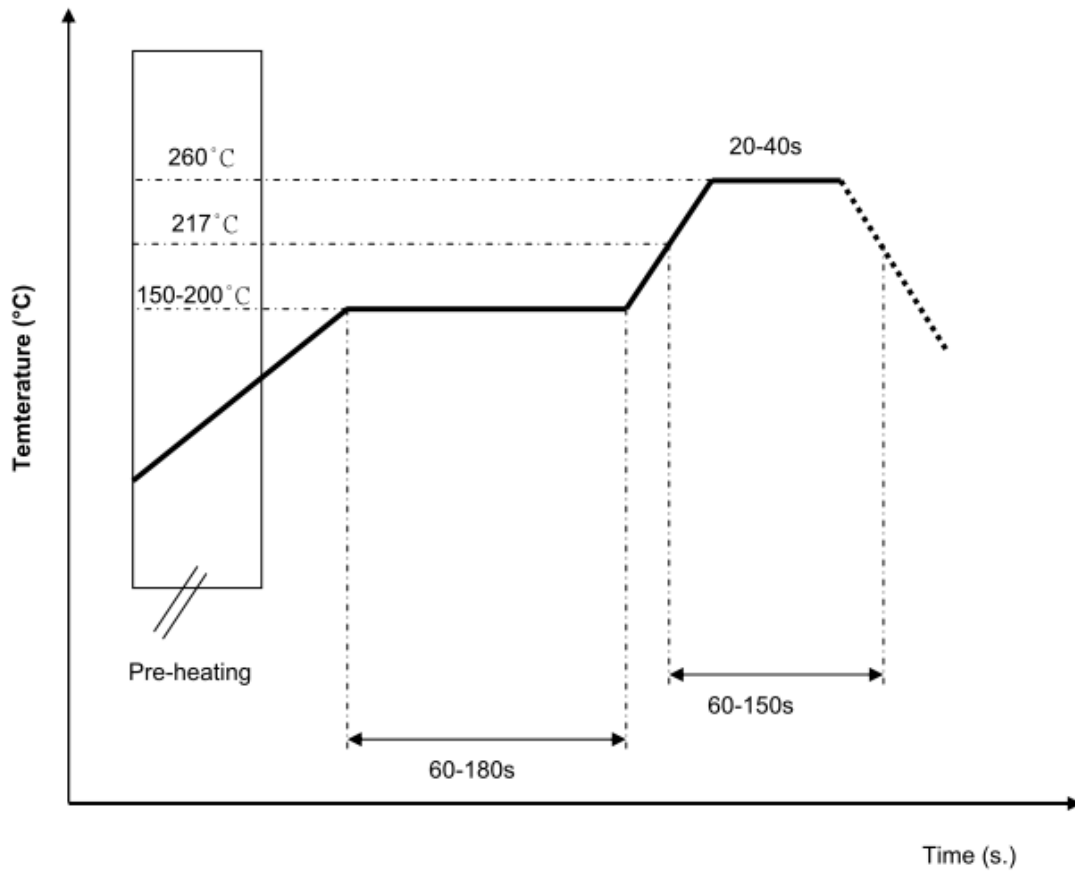

# 8. Packing

6000pcs/Reel

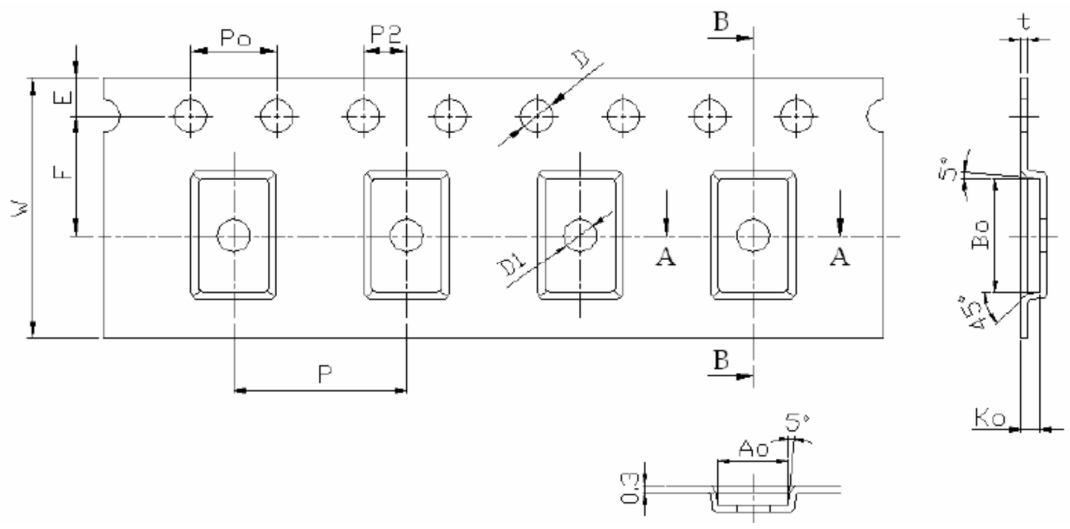

Feature	Specifications	Tolerances
W	12	±0.30
P	8	±0.10
E	1.75	±0.10
F	5.5	±0.10
P2	2	±0.10
D	1.2	±0.10
Po	4	±0.10
10Po	40	±0.20

Tape Dimensions (unit: mm)

Feature	Specifications	Tolerances
Ao	3.25	±0.10
Bo	5.25	±0.10
Ko	0.90	±0.10
t	0.30	±0.05

Pocket Dimensions (unit: mm)