

# SMT CURRENT SENSE TRANSFORMERS

## P820X Series

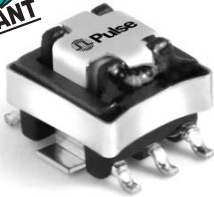

- Height:** 5.1mm Max\*
- Footprint:** 8.4mm x 7.2mm Max
- Current Rating:** up to 10A
- Frequency Range:** 50kHz to 1MHz
- Lower Primary DCR version available:** PA1005.XXX series

### Electrical Specifications @ 25°C — Operating Temperature -40°C to +130°C

Part <sup>6,7</sup> Number	Turns Ratio	Current <sup>2</sup> Rating (A)	Secondary Inductance (mH MIN)	DCR (mΩ MAX)		Hipot (V <sub>RMS</sub> )
				Primary (8-7)	Secondary (1-3)	
P8202	1:20	10	0.08	6	550	500
P8203	1:30	10	0.18	6	870	500
P8204	1:40	10	0.32	6	1140	500
P8205	1:50	10	0.50	6	1500	500
P8206	1:60	10	0.72	6	2250	500
P8207	1:70	10	0.98	6	4750	500
P8208	1:100	10	2.00	6	5500	500
P8209 <sup>7</sup>	1:125	10	3.00	6	6500	500

#### NOTES:

- The temperature of the component (ambient temperature plus temperature rise) must be within the specified operating temperature range.
- The maximum current rating is based upon temperature rise of the component and represents the DC current which will cause a typical temperature rise of 40°C with no airflow when both one turn windings connected in parallel.
- To calculate the value of the terminating resistor (Rt) use the following formula:  $R_t (\Omega) = V_{ref} * N / (I_{peak\_primary})$
- The peak flux density of the device must remain below 2000 Gauss. To calculate the peak flux density for uni-polar current use following formula:  $B_{PK} = 37.59 * V_{REF} * (Duty\_Cycle\_Max) * 10^5 / (N * Freq\_kHz)$   
\* for bi-polar current applications divide B<sub>PK</sub> (as calculated above) by 2.
- Part numbers **P8222** to **P8229** are reverse polarity versions of **P820X**.
- Optional Tape & Reel packaging can be ordered by adding a "T" suffix to the part number (i.e. P8202 becomes P8202T). Pulse complies to industry standard tape and reel specification EIA481.
- To order RoHS compliant part, add the suffix "NL" to the part number (i.e. P8202 becomes P8202NL and P8202T becomes P8202NLT). Please note that the P8209 part is not available in an RoHS compliant version.

### Mechanical

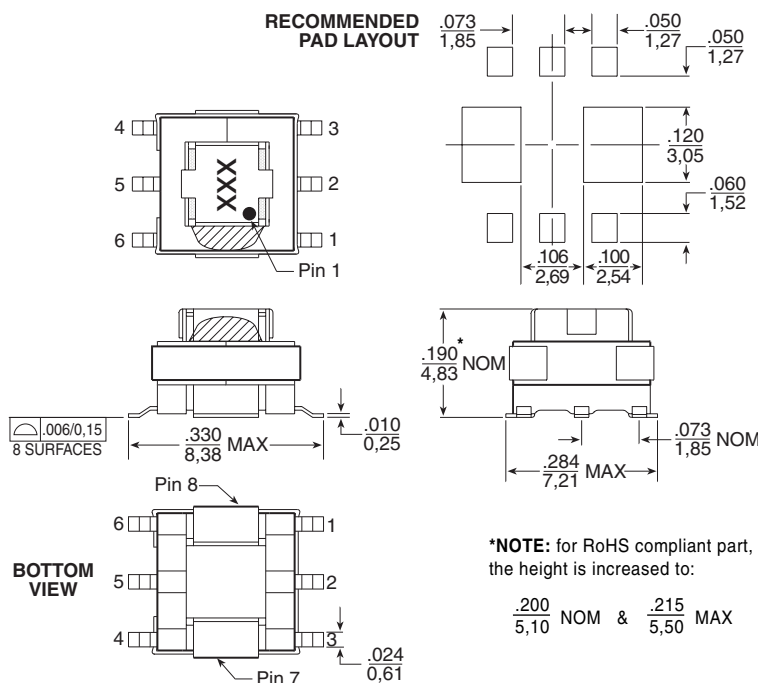

### Schematic

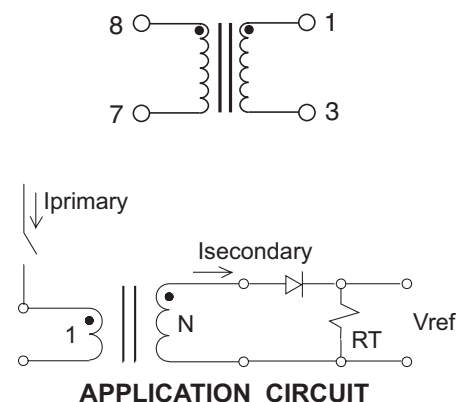

Weight ..... 0.34 grams  
 Tray ..... .120/tray  
 Tape & Reel ..... .900/reel  
 Coplanarity ..... .004 inches

Dimensions:  $\frac{\text{Inches}}{\text{mm}}$   
 Unless otherwise specified, all tolerances are  $\pm \frac{.010}{0.25}$