



Underside View
(this side faces the passenger)



Top View
(this side faces the sky)



MA204.A.LB.002

Specification

Part No.	MA204.A.LB.002
Product Name	Stingray MA204 Stingray 2in1 - GPS/GLONASS - Cellular Adhesive Antenna
Feature	GPS/GLONASS - High gain LNA up to 28dB Penta-band Cellular – 800MHz to 2200MHz GSM/CDMA/PCS/DCS/UMTS/GPRS/EDGE/HSPA Height 10.8mm Diameter 55.1mm RoHS Compliant

1. Introduction

This is a 2in1 combination high performance GPS/GLONASS and Penta-band Cellular (GSM /CDMA/PCS/DCS/ / UMTS / GPRS / EDGE / HSPA) antenna to simplify AVL or Fleet management antenna systems worldwide. Its high quality low profile covert housing can be attached onto the glass or even out

of sight under the dashboard. This combination of a high gain GPS/GLONASS antenna and a leading edge penta band cellular antenna is ideal for those applications that require durability, small size and covert installation, and reliable reception and transmission crossing through different mobile networks.

The standard version has 3 metres RG174 cable and SMA(M) connector on both GPS/GLONASS and Cellular.

The cables and connectors are completely customizable according to customer request.

1.1 Features

GPS/GLONASS

High LNA Gain up to 28 dB
Antenna Gain 28 ± 2 dB
Miniaturized to 55*11.8mm
Low Noise 2.2 dB max

Cellular

Advanced penta-band cellular antenna
(GSM/CDMA/PCS/DCS/UMTS/GPRS/EDGE/HSPA)

Other

Water Resistant IP 65 (IP 67 "W" version also available on request)
Quality textured covert design. Low profile
UV resistant ABS housing
Comes with high grade 3M double sided tape for quick and easy mounting
Customizable cables and connectors

2. Antenna Block Diagram

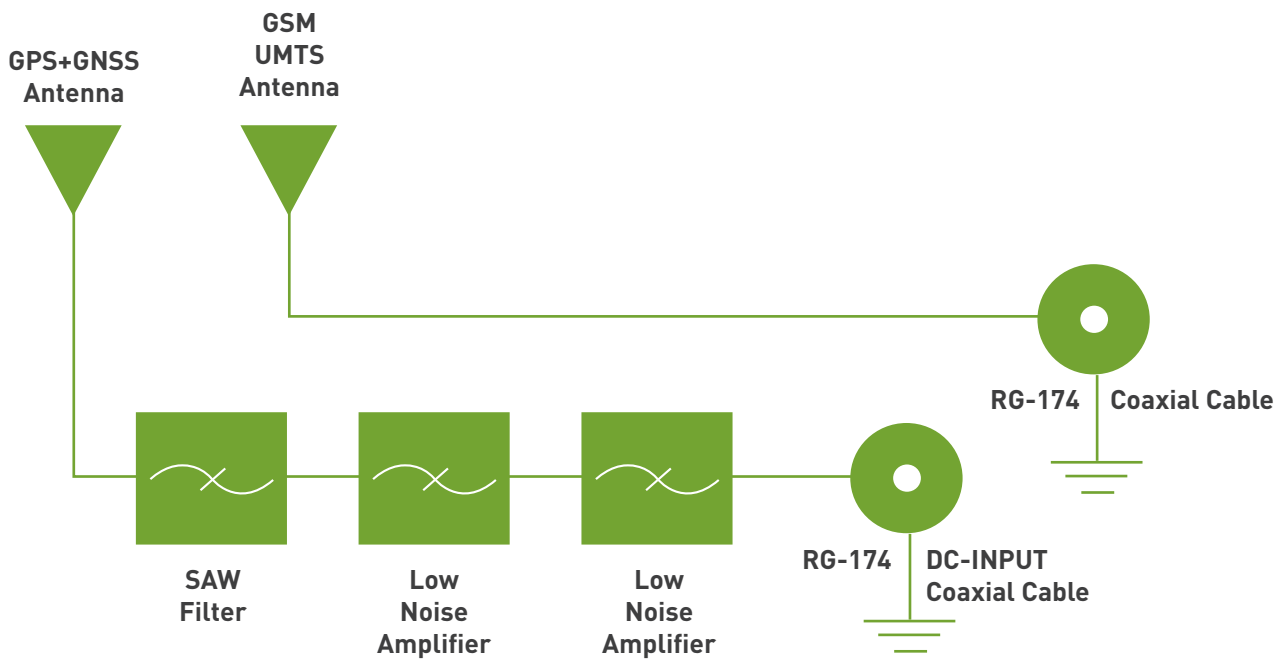

3. Specification

3.1 Performance Specifications

Items	GPS/GLONASS Antenna	Cellular Antenna
Features	High performance GPS/GLONASS ceramic patch antenna with cutting edge low noise amplifier	800MHz to 2200MHz
Frequency	1575.42 MHz ± 3MHz 1602 MHz ± 0.5MHz	As above
Gain	28 dB typ.	As patterns
VSWR	2.0:1	2.5:1
Impedance	50Ω	50Ω
DC Power Input	3.3V	
Power Consumption	10mA Typ.	
Noise Figure	2.2 dB Max	
Cable / Connector	Standard 1/2/3/5m RG-174 Cables and Connectors Fully Customizable	Standard 1/2/3/5m RG-174 Cables and Connectors Fully Customizable
Operating Temperature	-40°C ~ +85°C	-40°C ~ +85°C
Storage Temperature	-40°C ~ +95°C	-40°C ~ +95°C
Size	55mm * 10.8mm	
Housing	UV resistant ABS	

***Note:** specifications may be subject to change

4. GPS/GLONASS Antenna - Setup

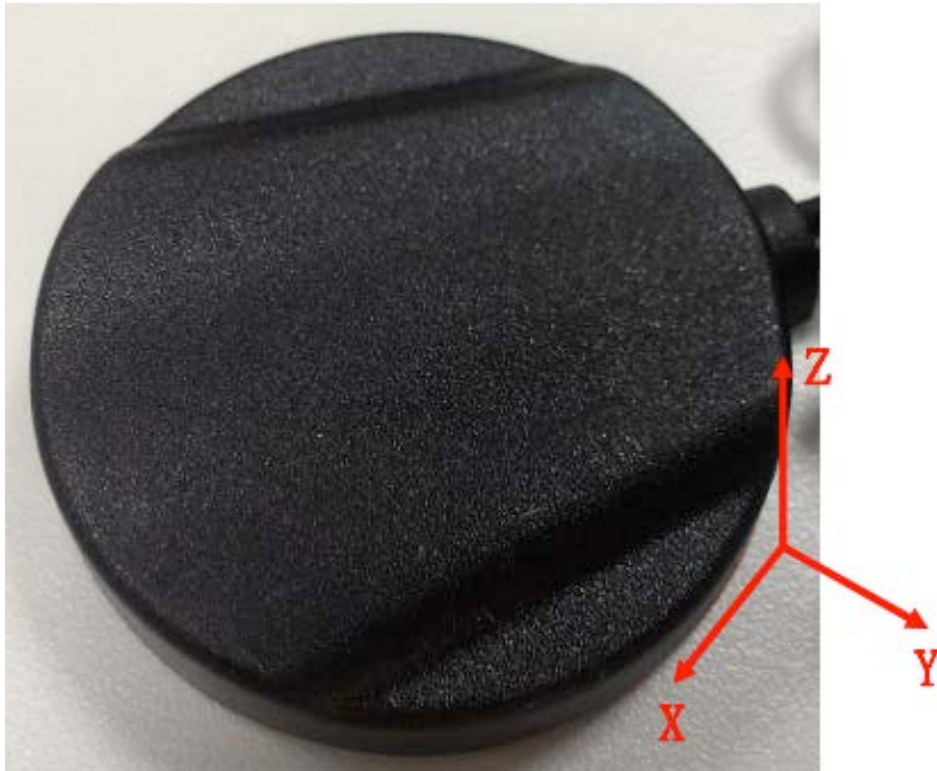

4.1 GPS/GLONASS Antenna

4.1.1 Smith Chart - Impedance

Tr1 S11 Smith (R+j)(Ω) Scale 1.000U [F2]

1	1.5754200 GHz	78.860 Ω	13.968 Ω
> 2	1.6020000 GHz	31.850 Ω	-6.0578 Ω

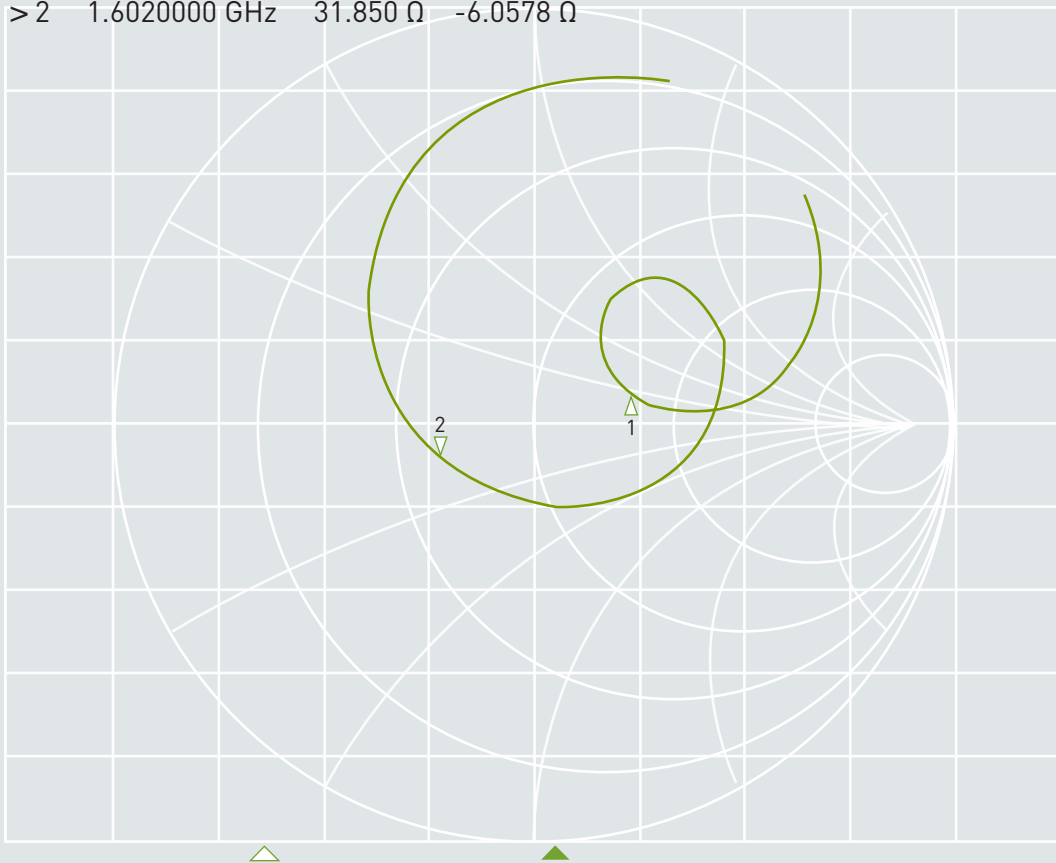

4.1.2 VSWR

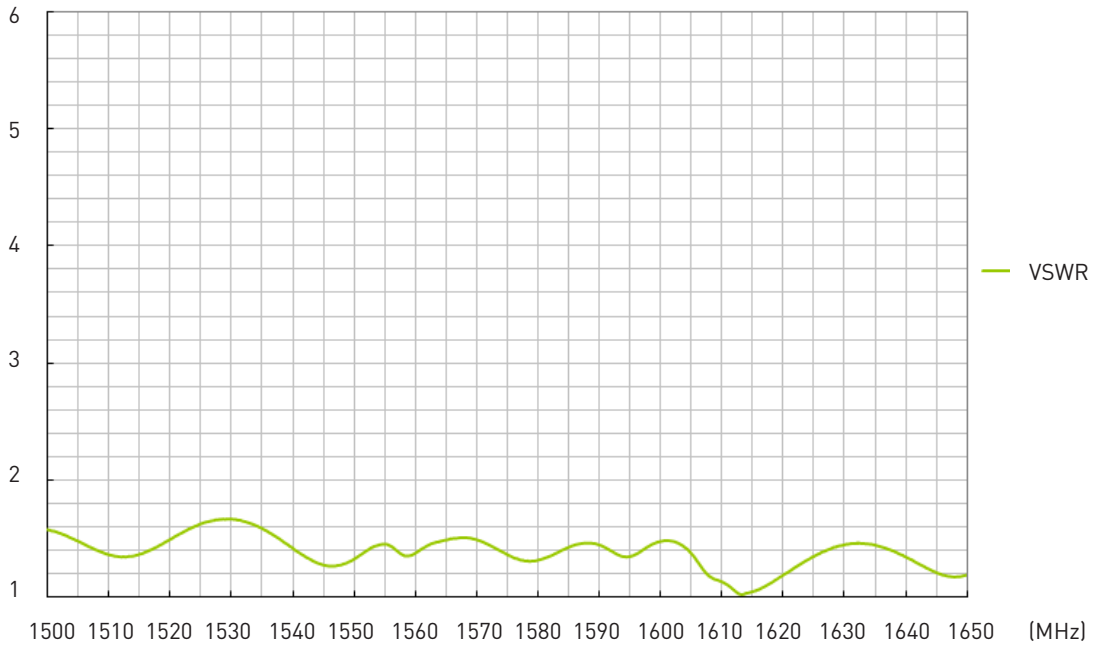

4.1.3 Return Loss

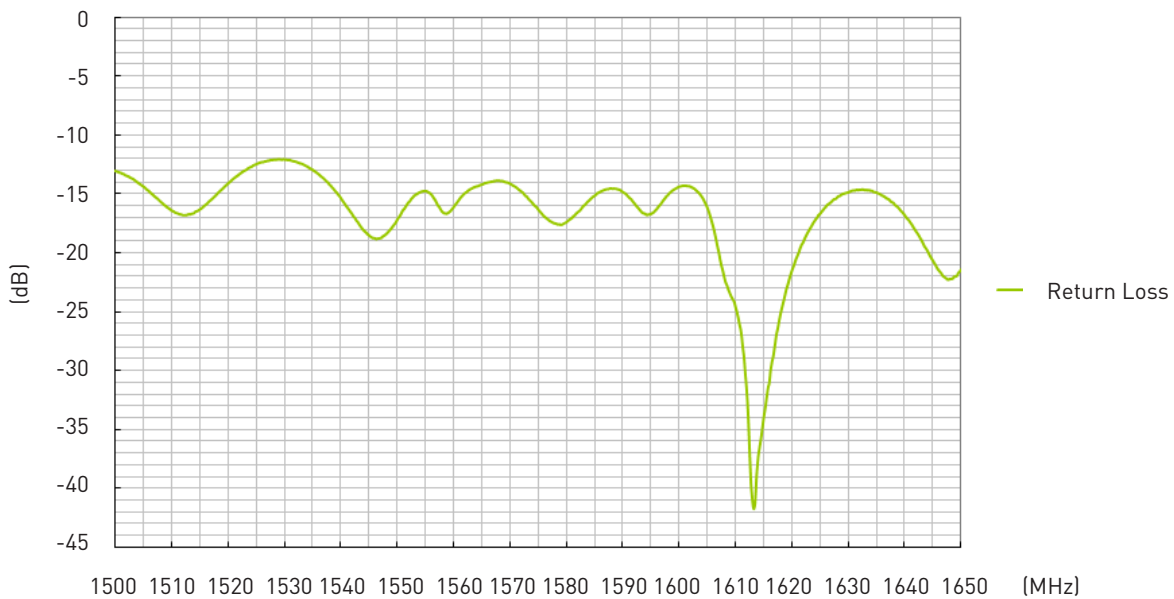

4.2 GPS/GLONASS Antenna Radiation Patterns

1575MHz

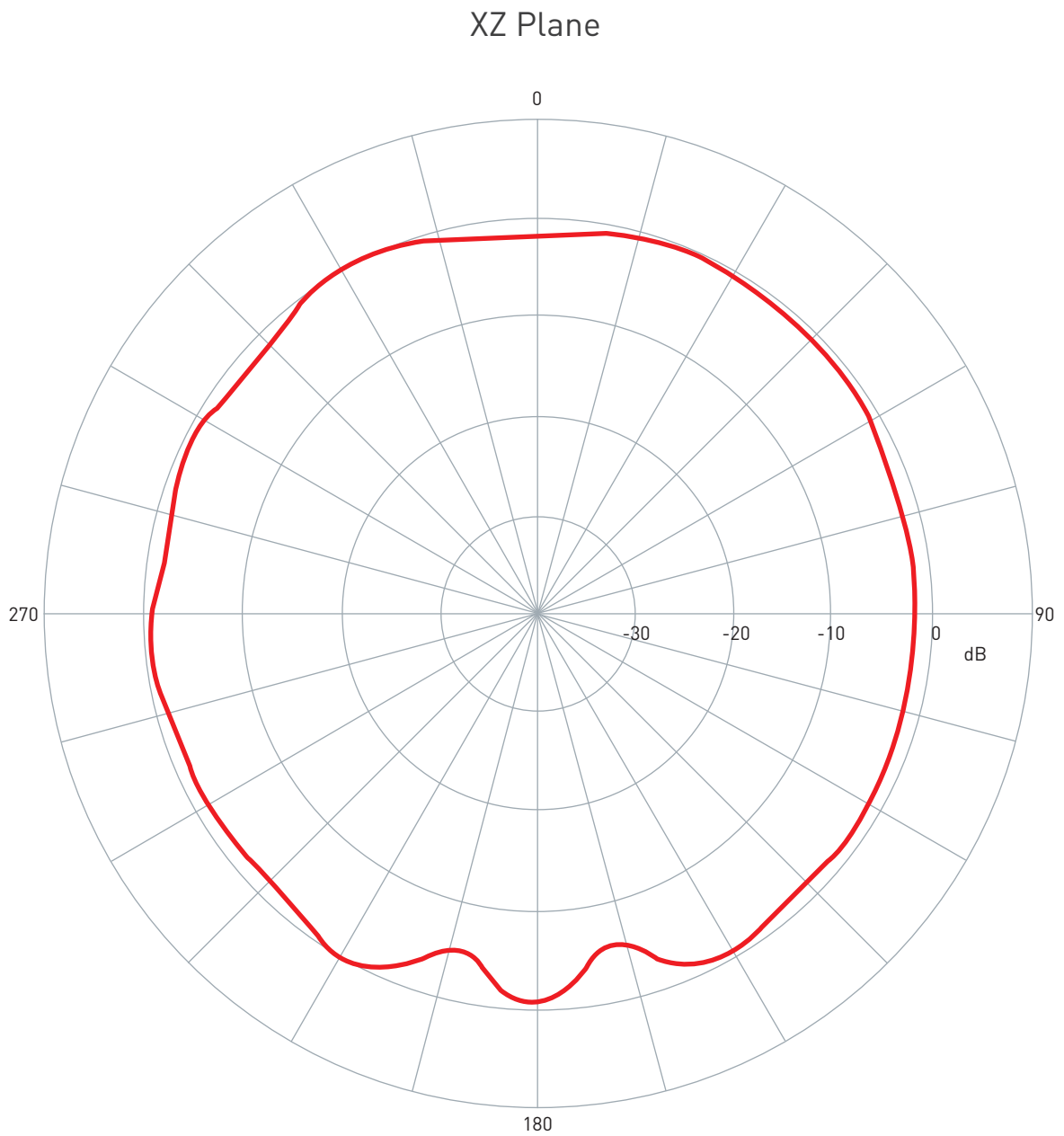

4.2 GPS/GLONASS Antenna Radiation Patterns

1575MHz

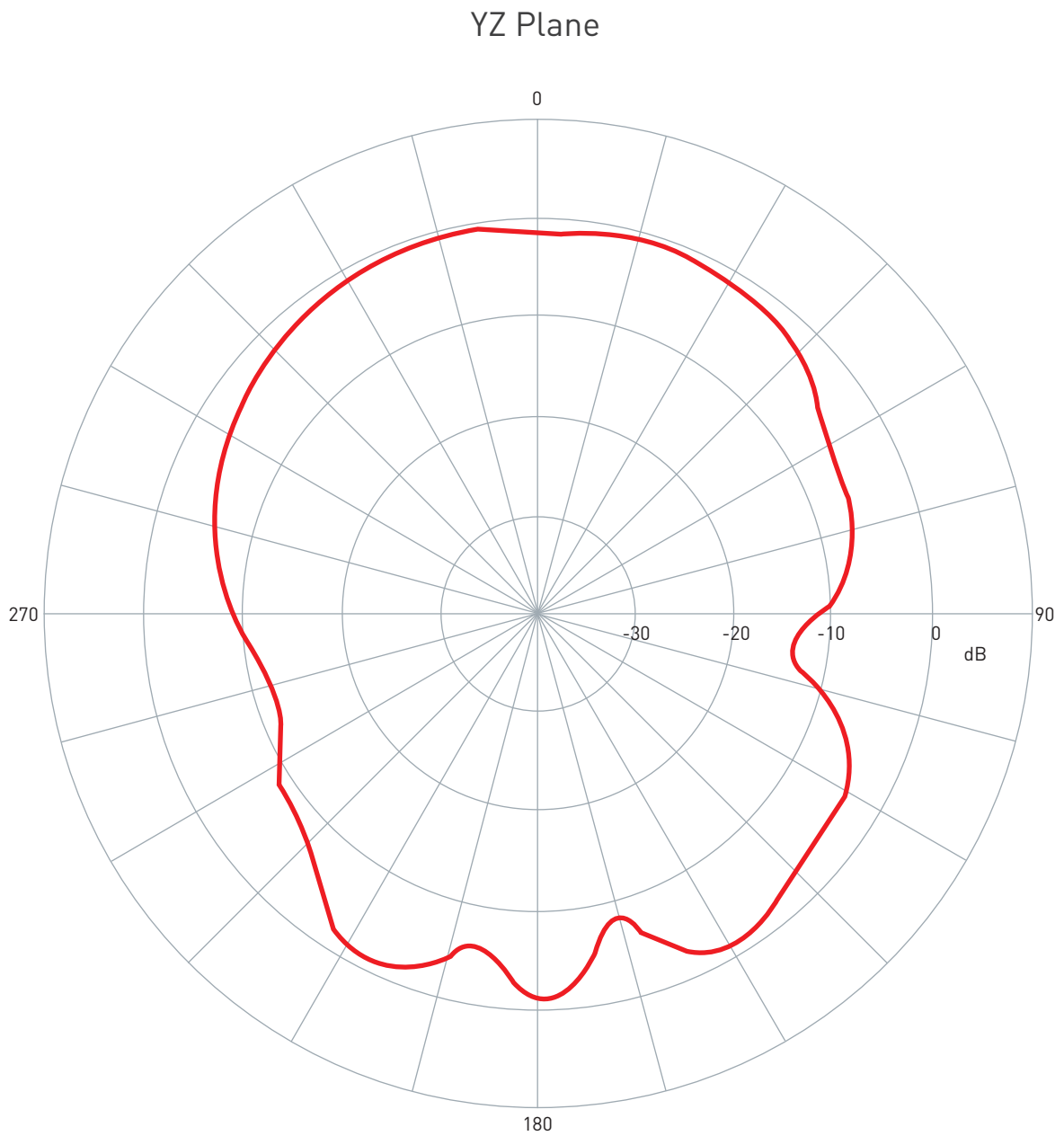

4.2 GPS/GLONASS Antenna Radiation Patterns

1602MHz

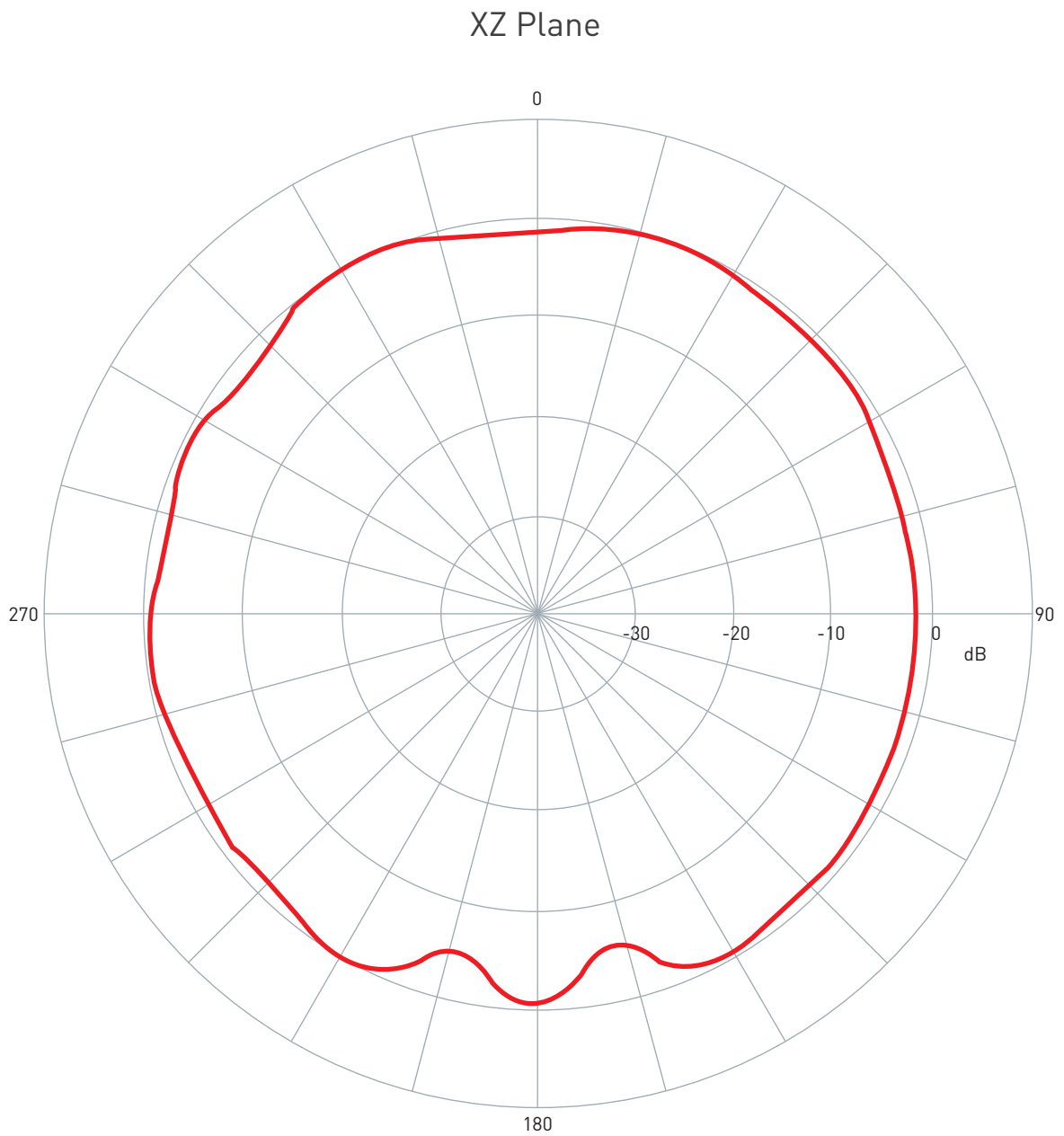

4.2 GPS/GLONASS Antenna Radiation Patterns

1602MHz

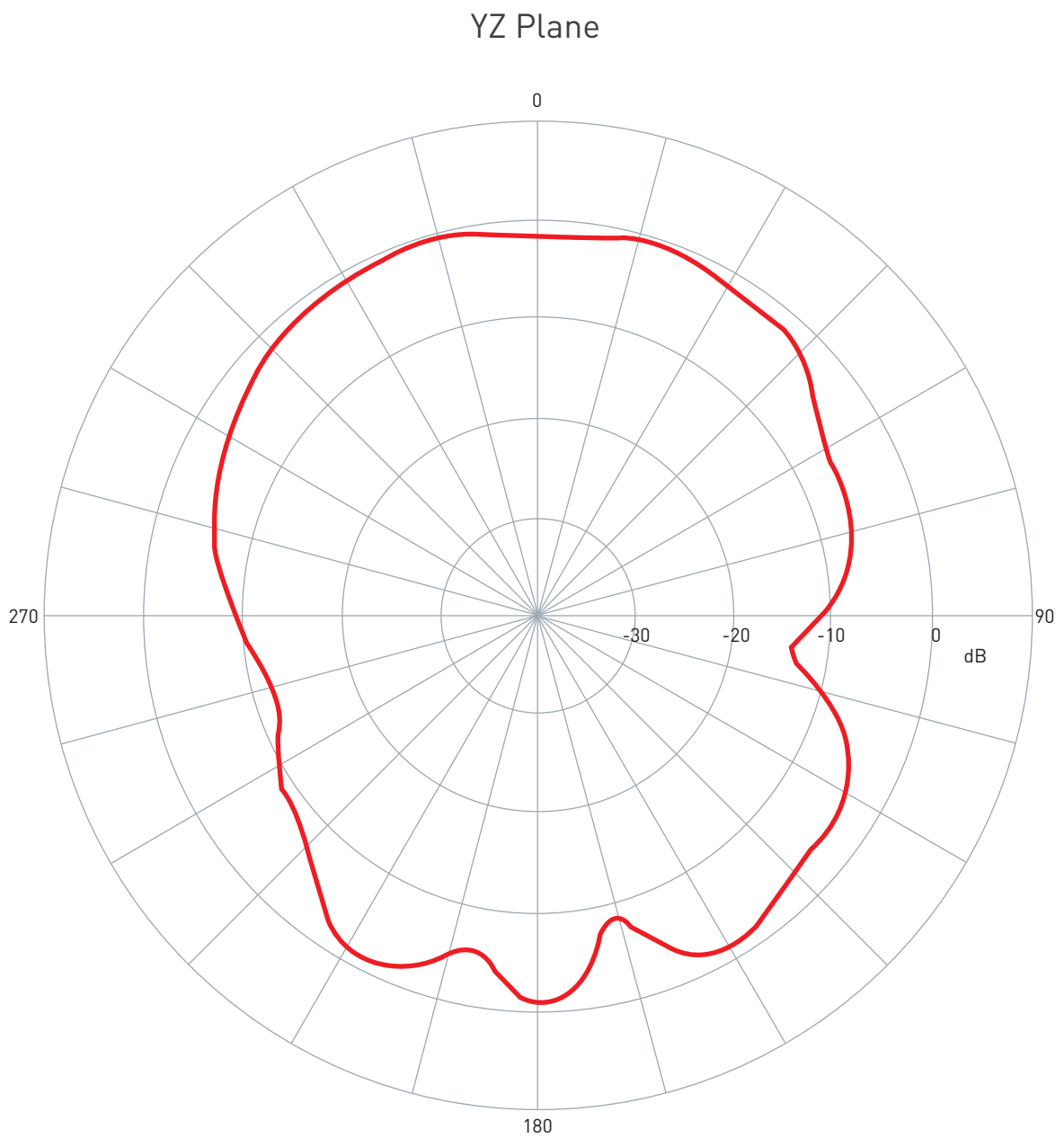

4.3 GPS/GLONASS Antenna Gain Chart

Frequency(MHz)	Peak Gain(dBi)	Efficiency(%)
1575	1.36	50.13
1602	0.09	52.64

4.4 GPS/GLONASS LNA Gain

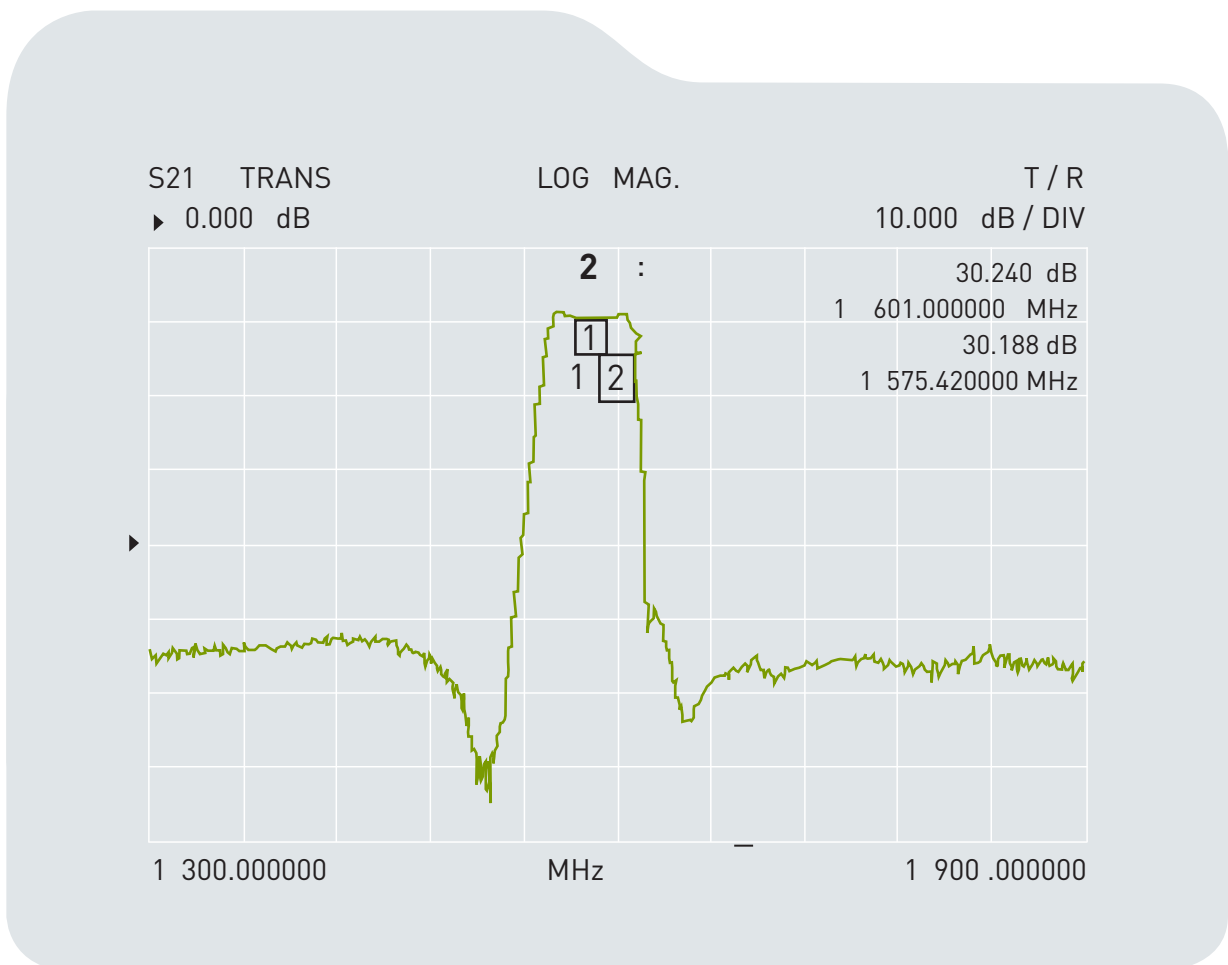

4.5 GPS/GLONASS LNA Output Return Loss

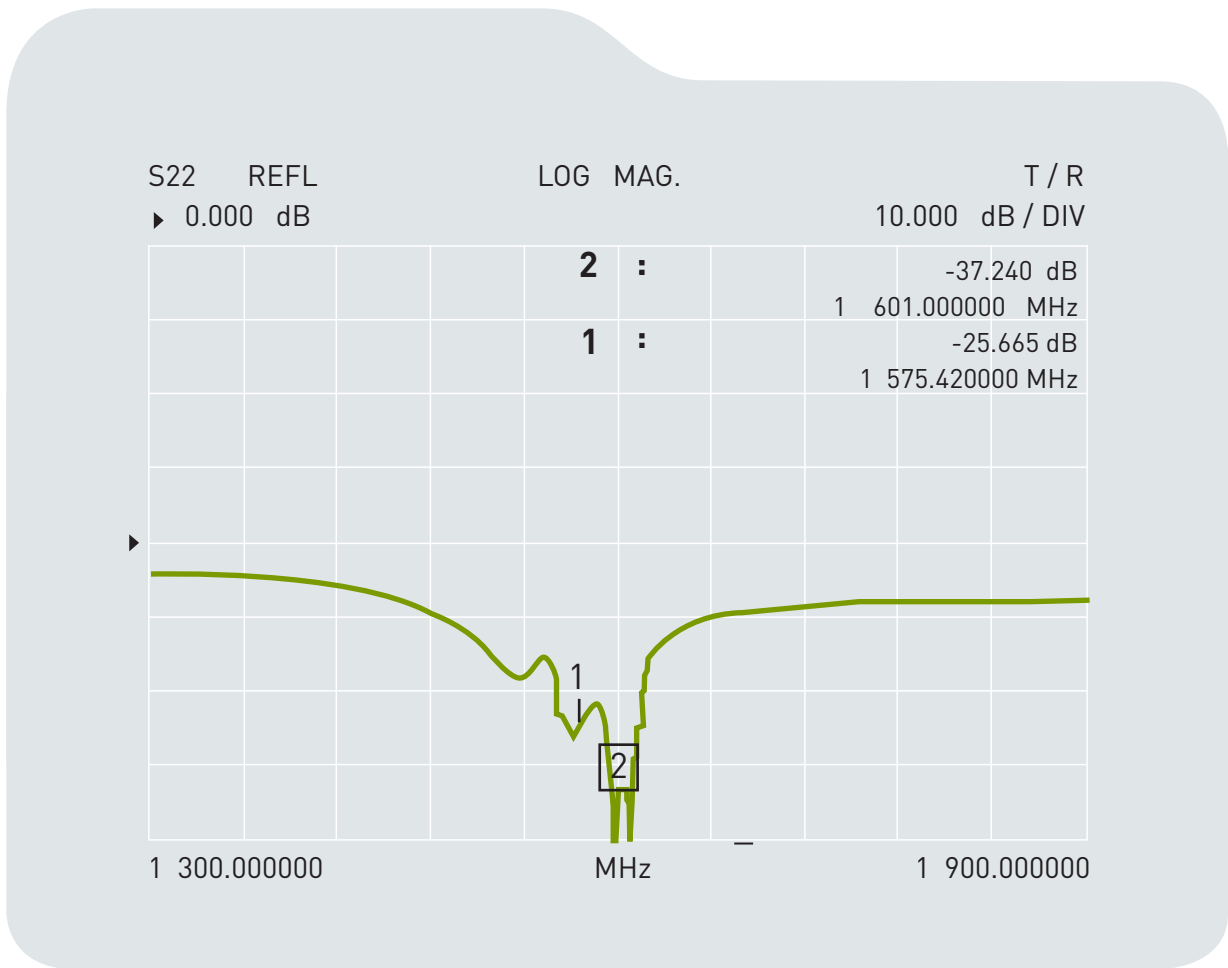

5. Cellular Antenna

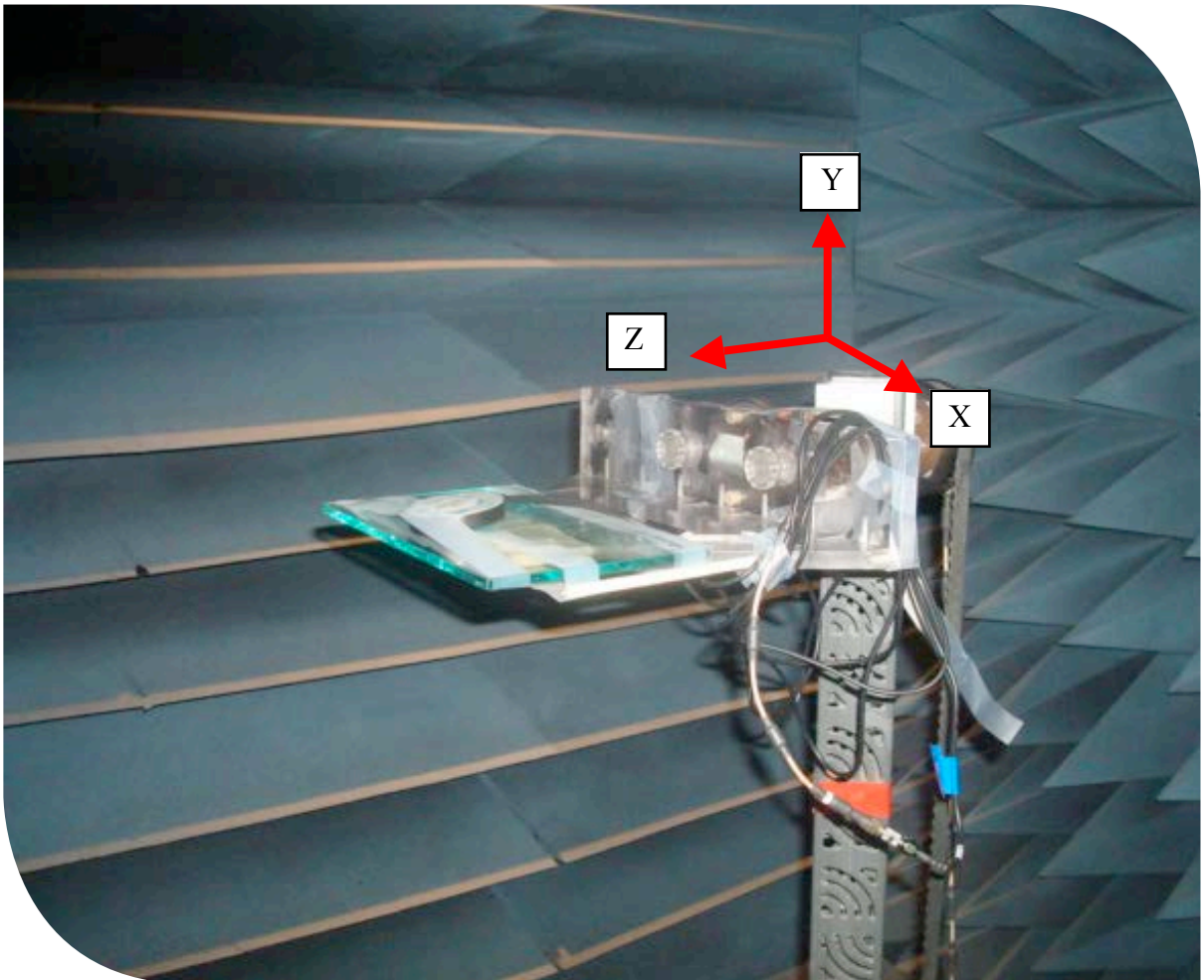

5.1 Return Loss

With Housing, Glass Mount (RG-174, length = 3M)

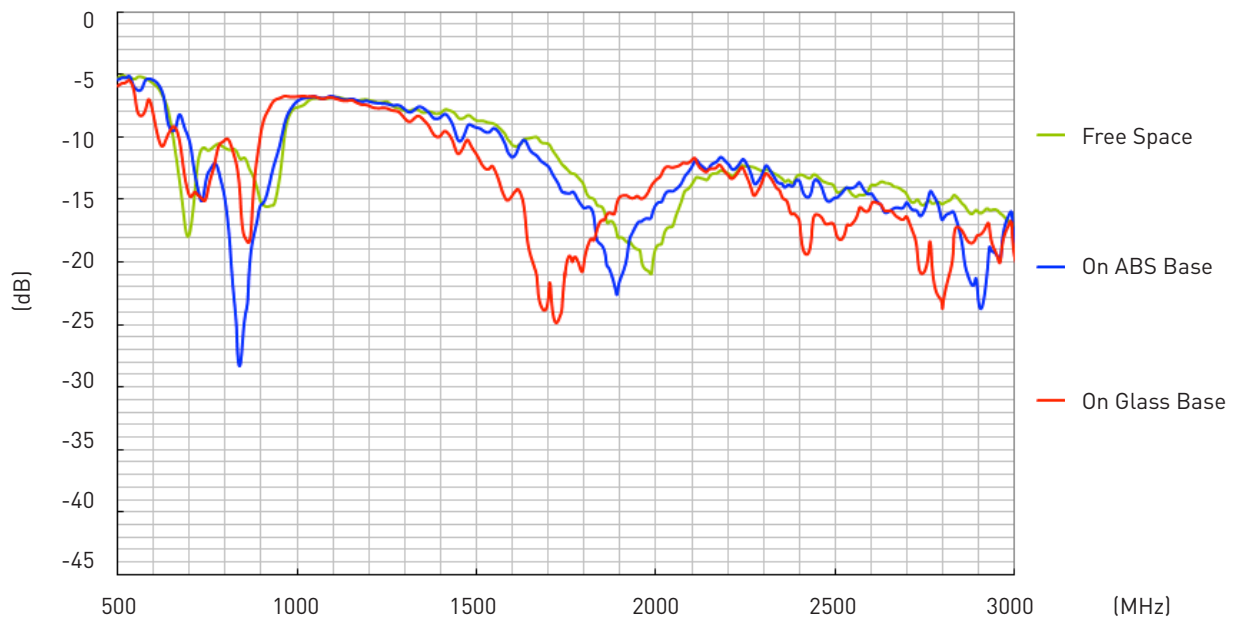

5.2 Antenna Characteristics

5.2.1 Return Loss

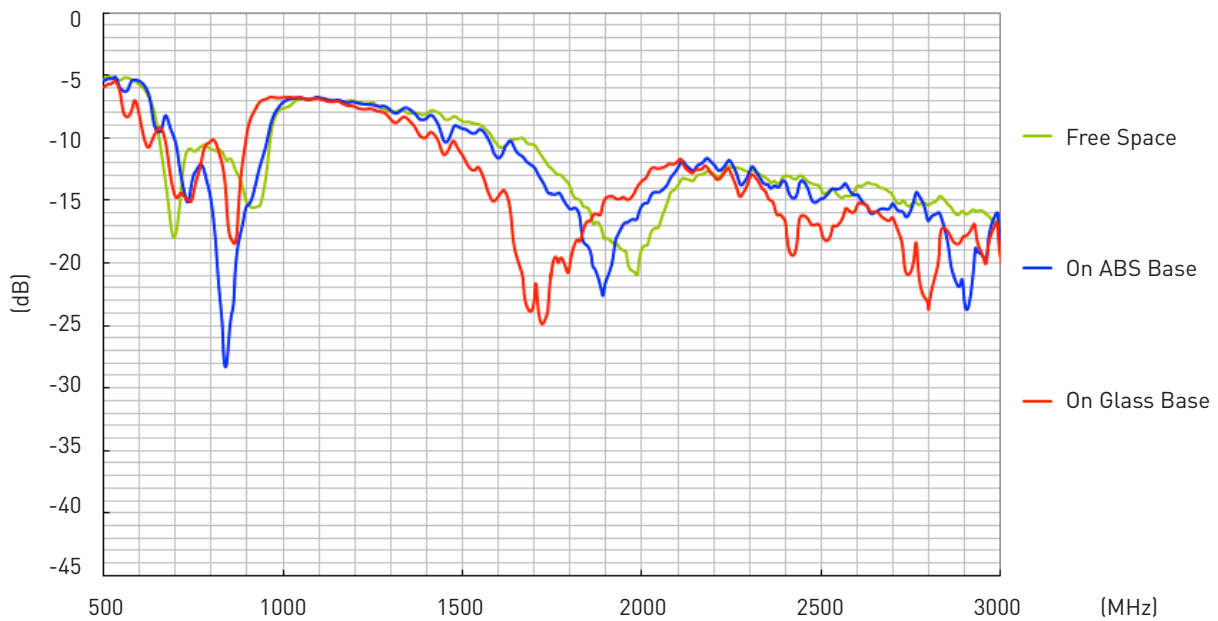

5.2.2 Efficiency

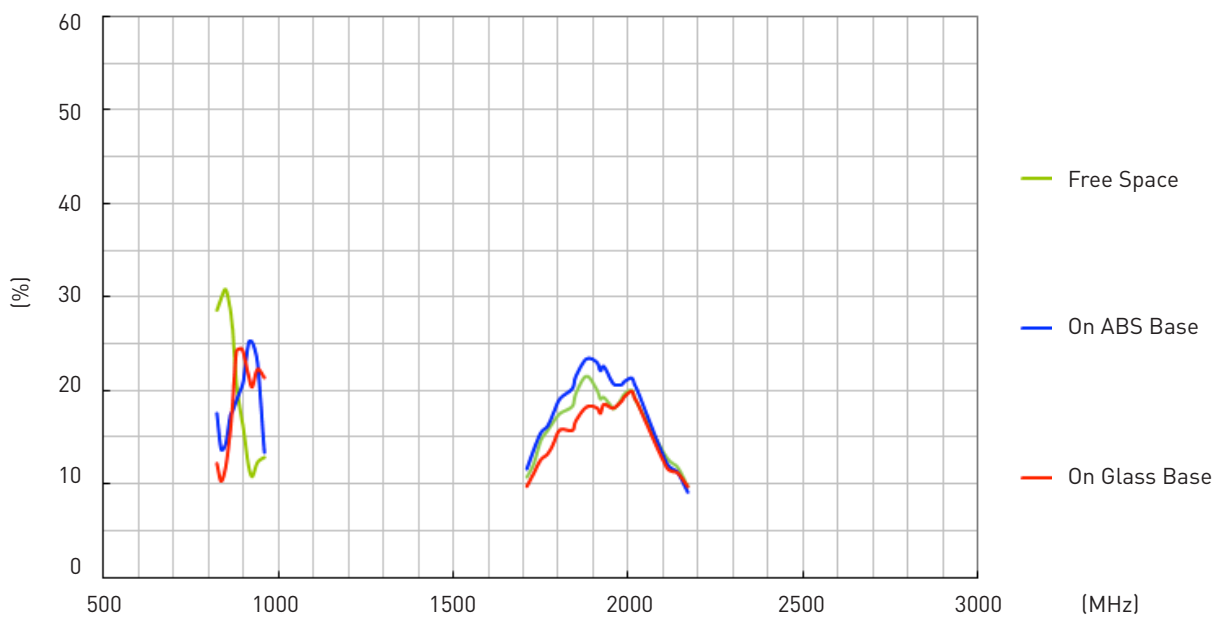

5.2 Antenna Characteristics

5.2.3 Peak Gain

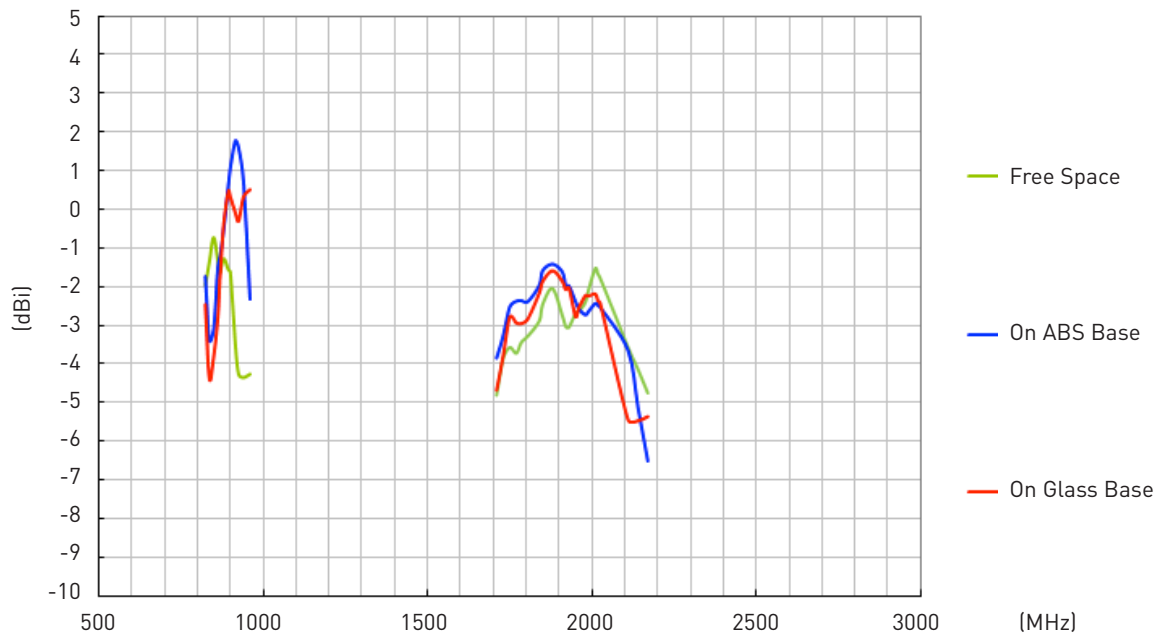

5.2.4 Average Gain

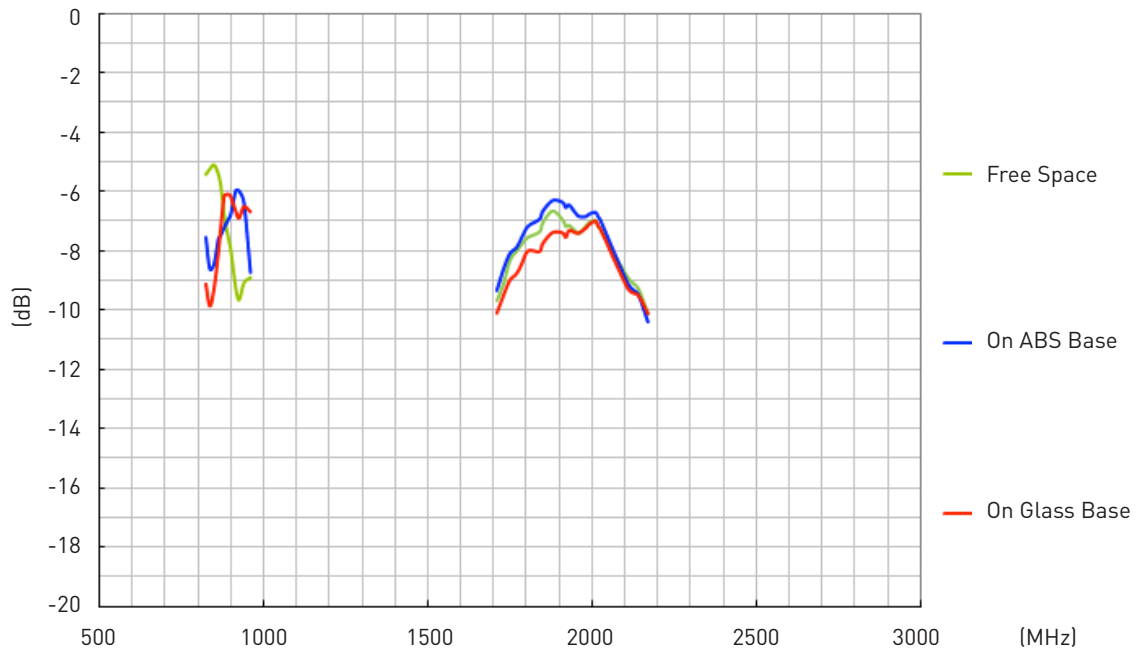

5.3 Radiation Patterns

5.3.1 Free Space

XY Plane

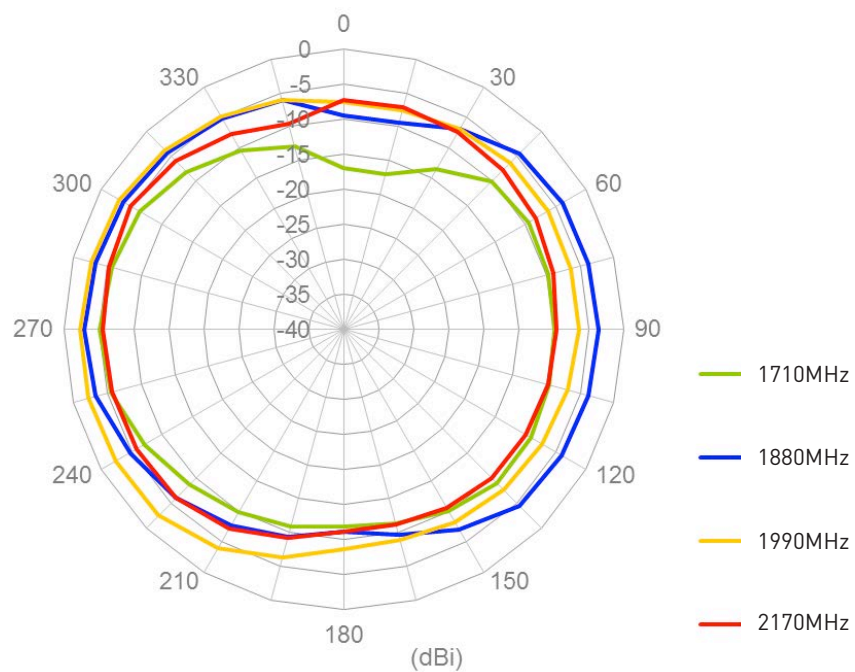
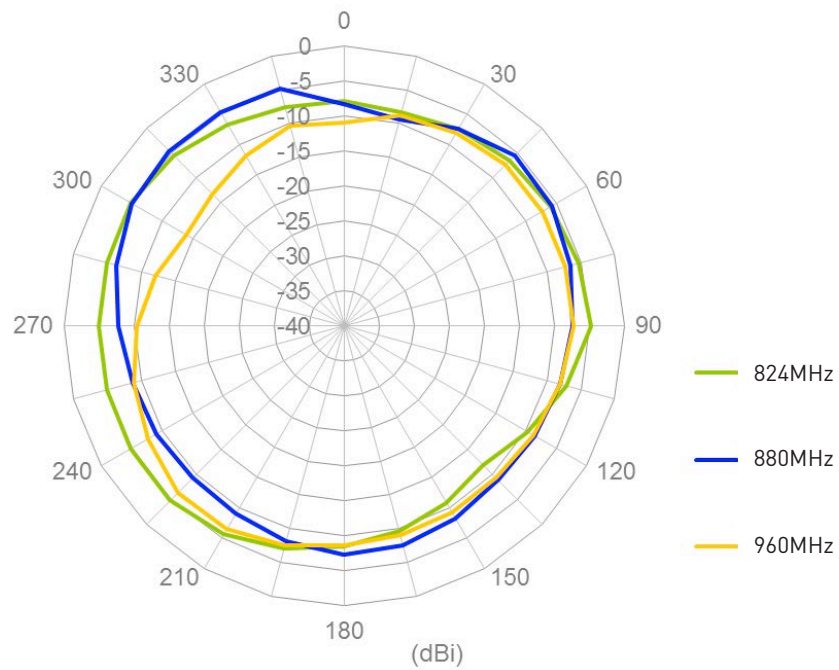

5.3 Radiation Patterns

5.3.1 Free Space

XZ Plane

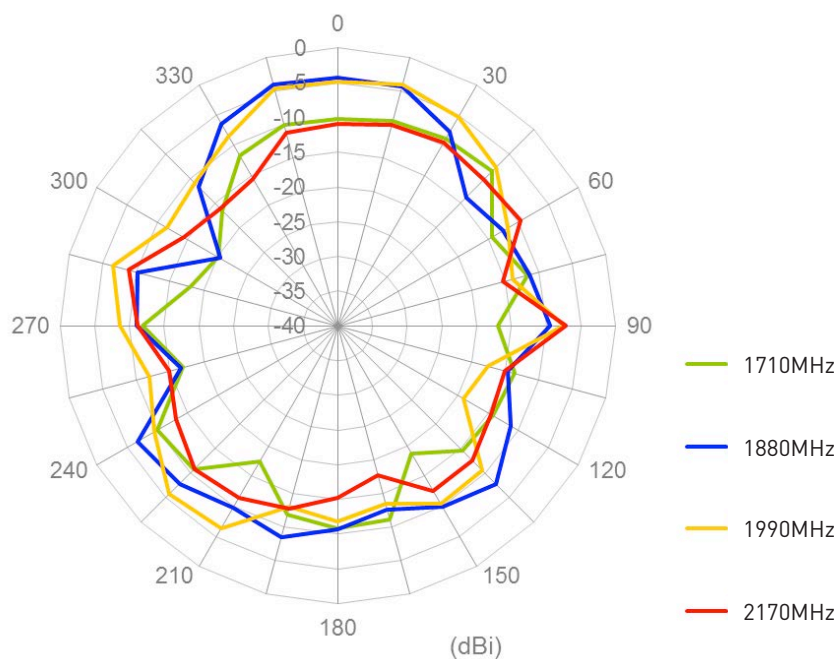
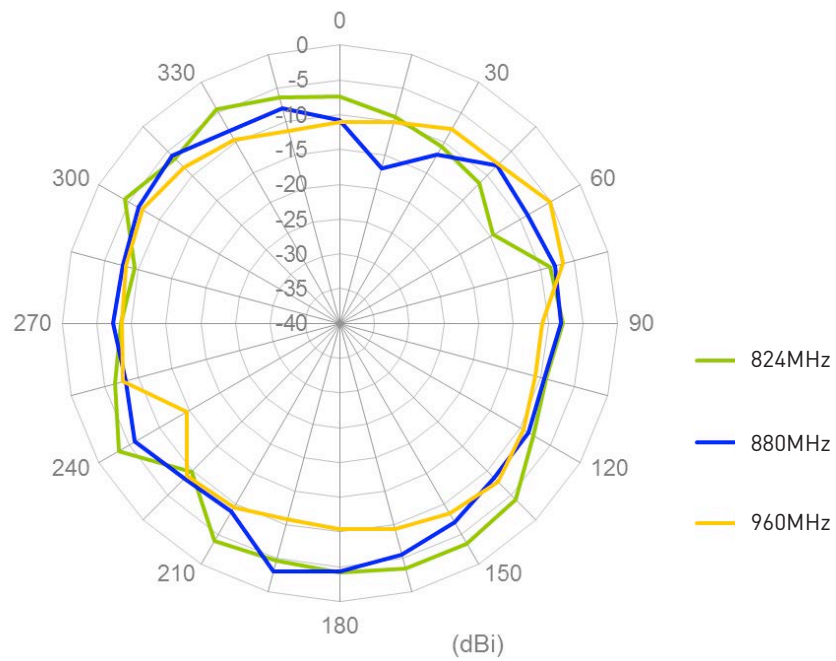

5.3 Radiation Patterns

5.3.2 On ABS Base

XY Plane

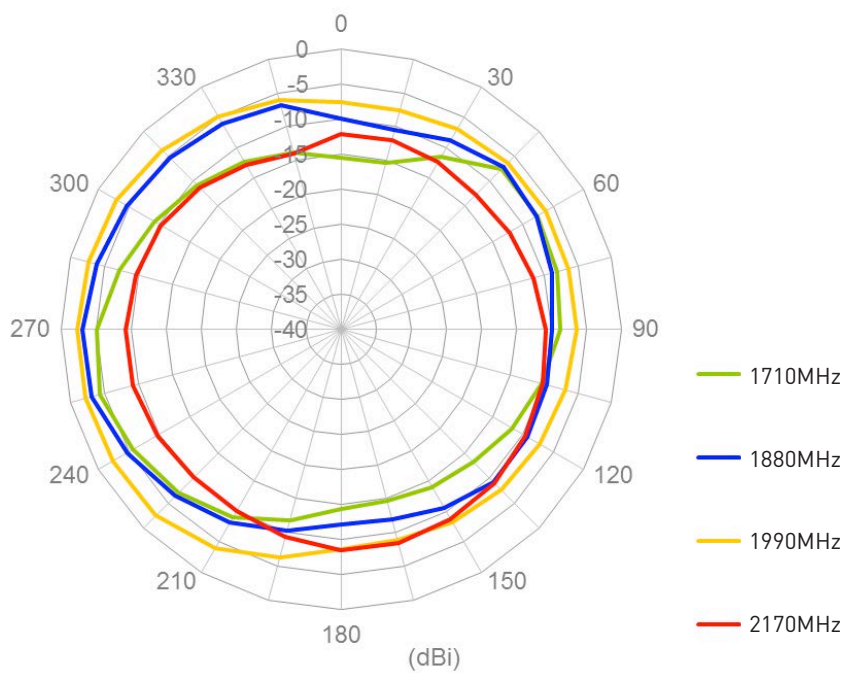
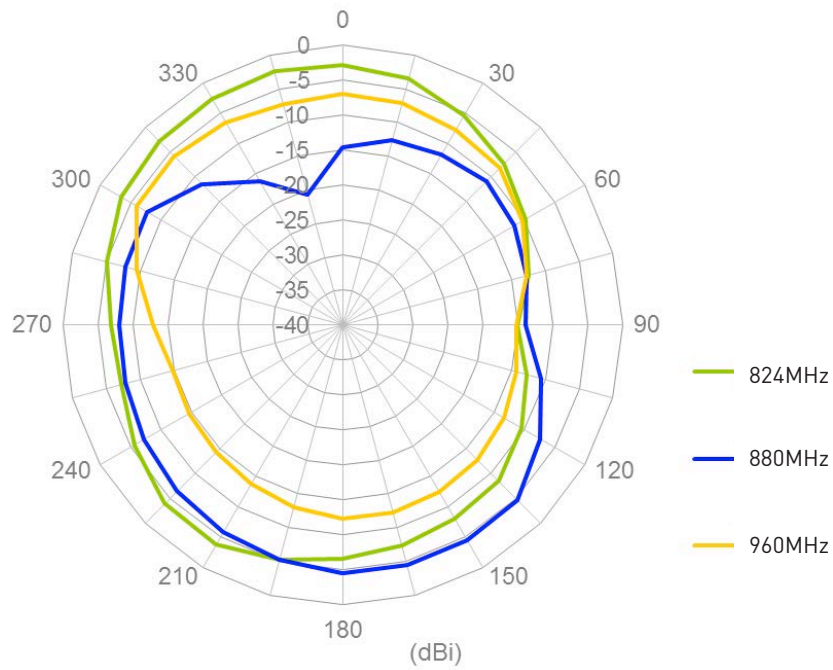

5.3 Radiation Patterns

5.3.2 On ABS Base

XZ Plane

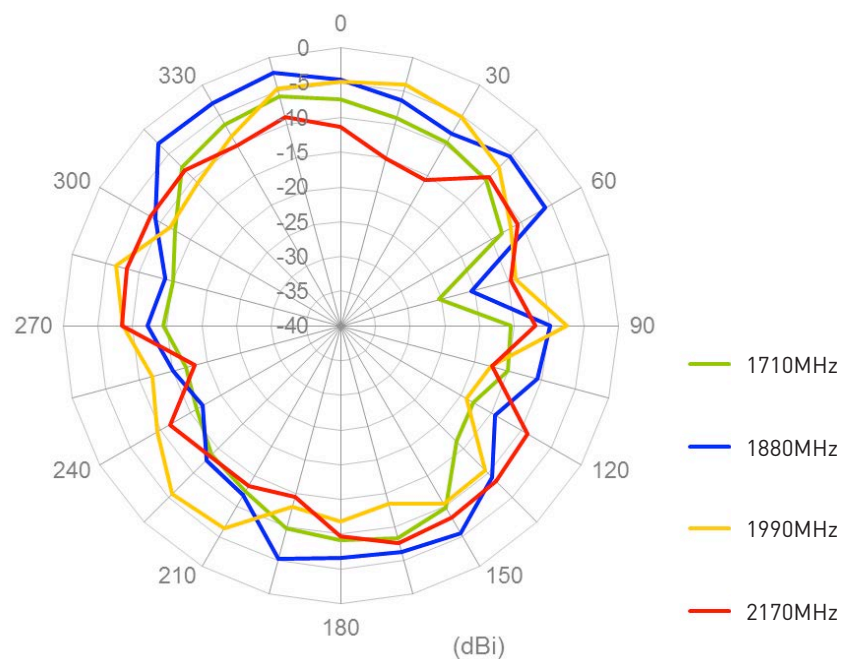
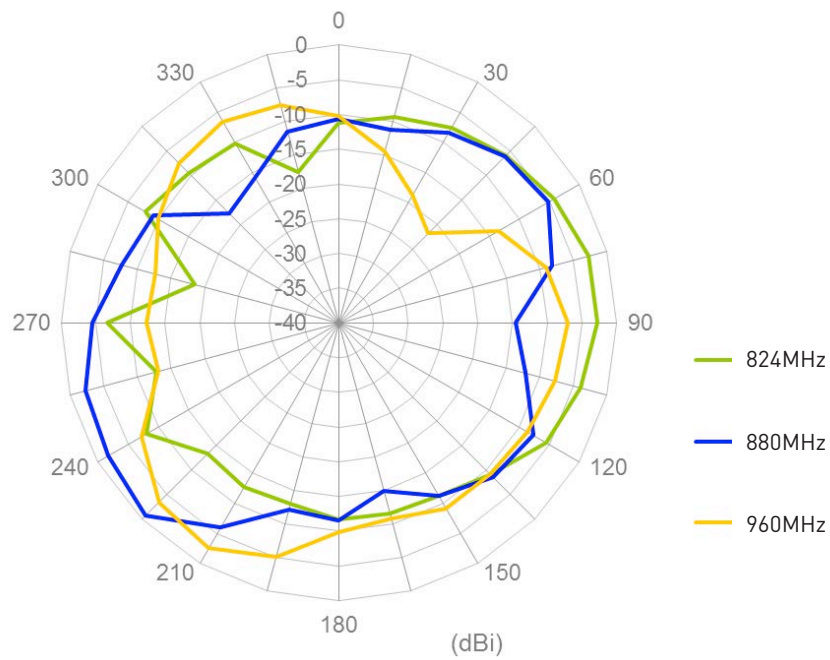

5.3 Radiation Patterns

5.3.3 On Glass Base

XY Plane

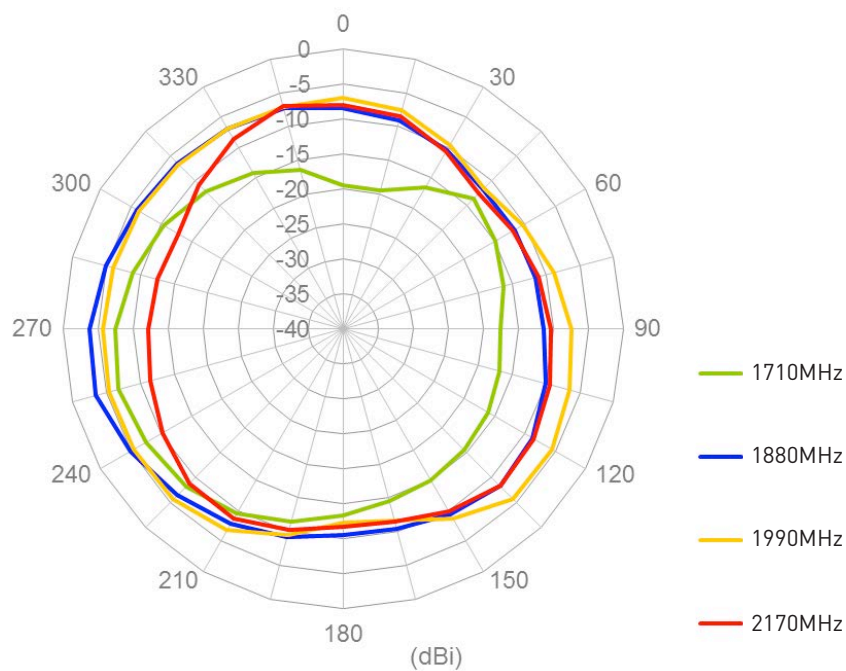
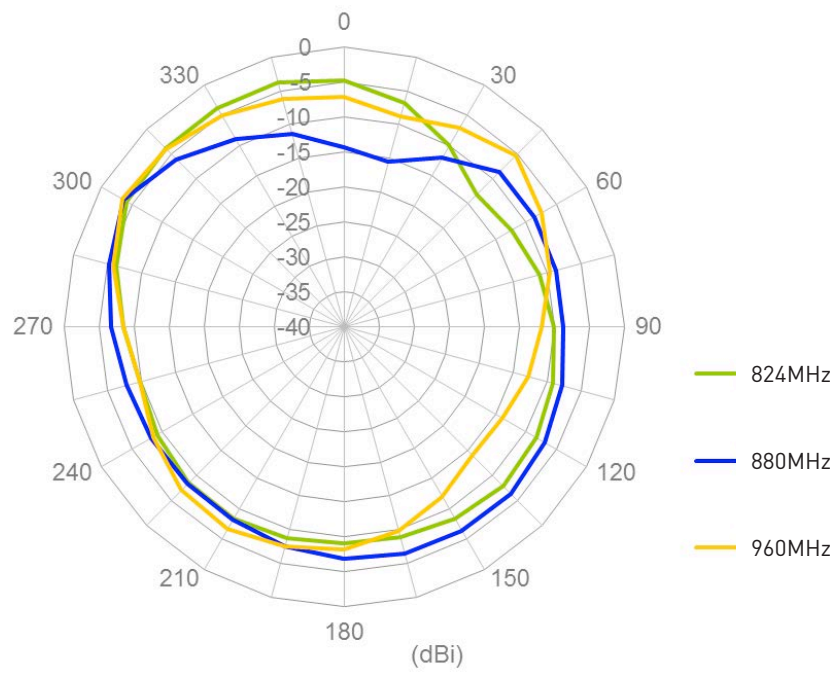

5.3 Radiation Patterns

5.3.3 On Glass Base

XZ Plane

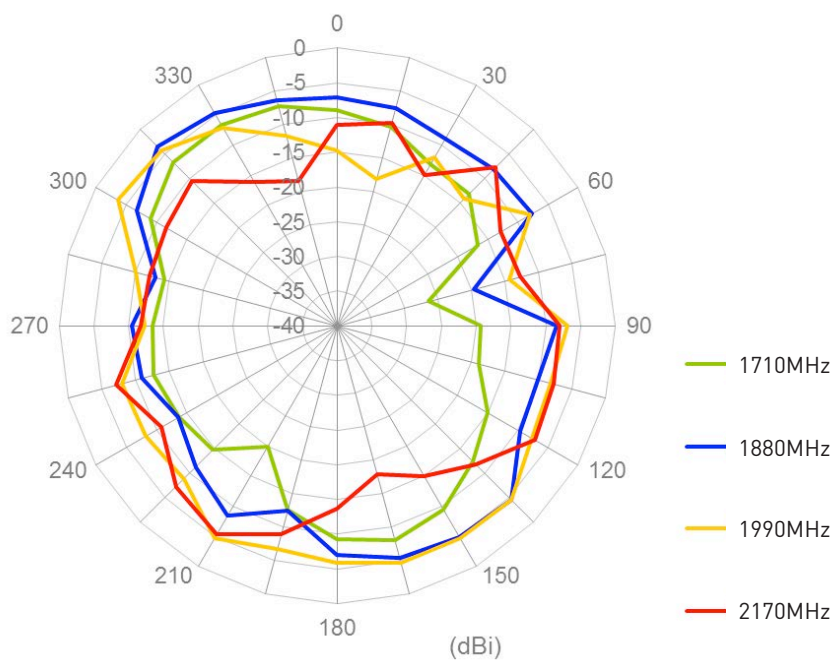
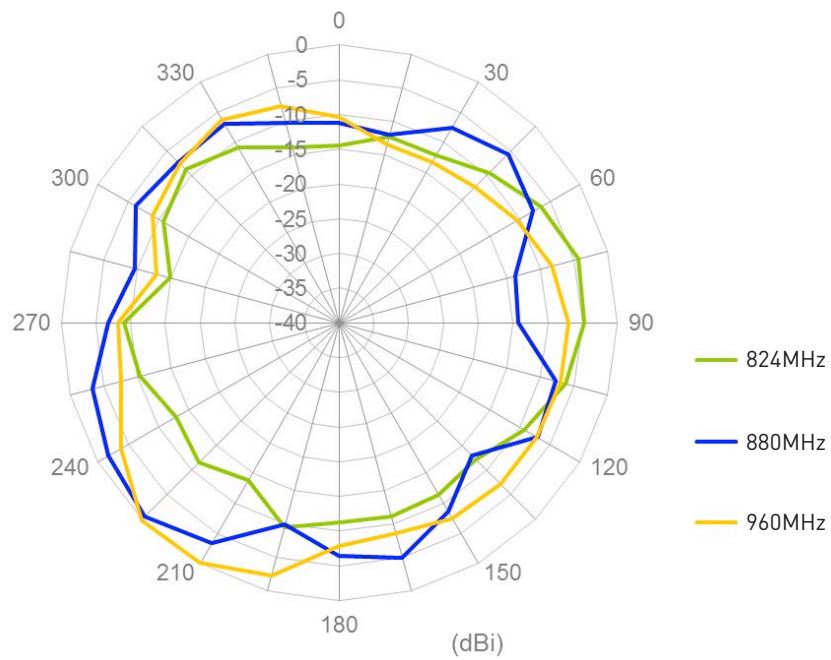

6. Drawing

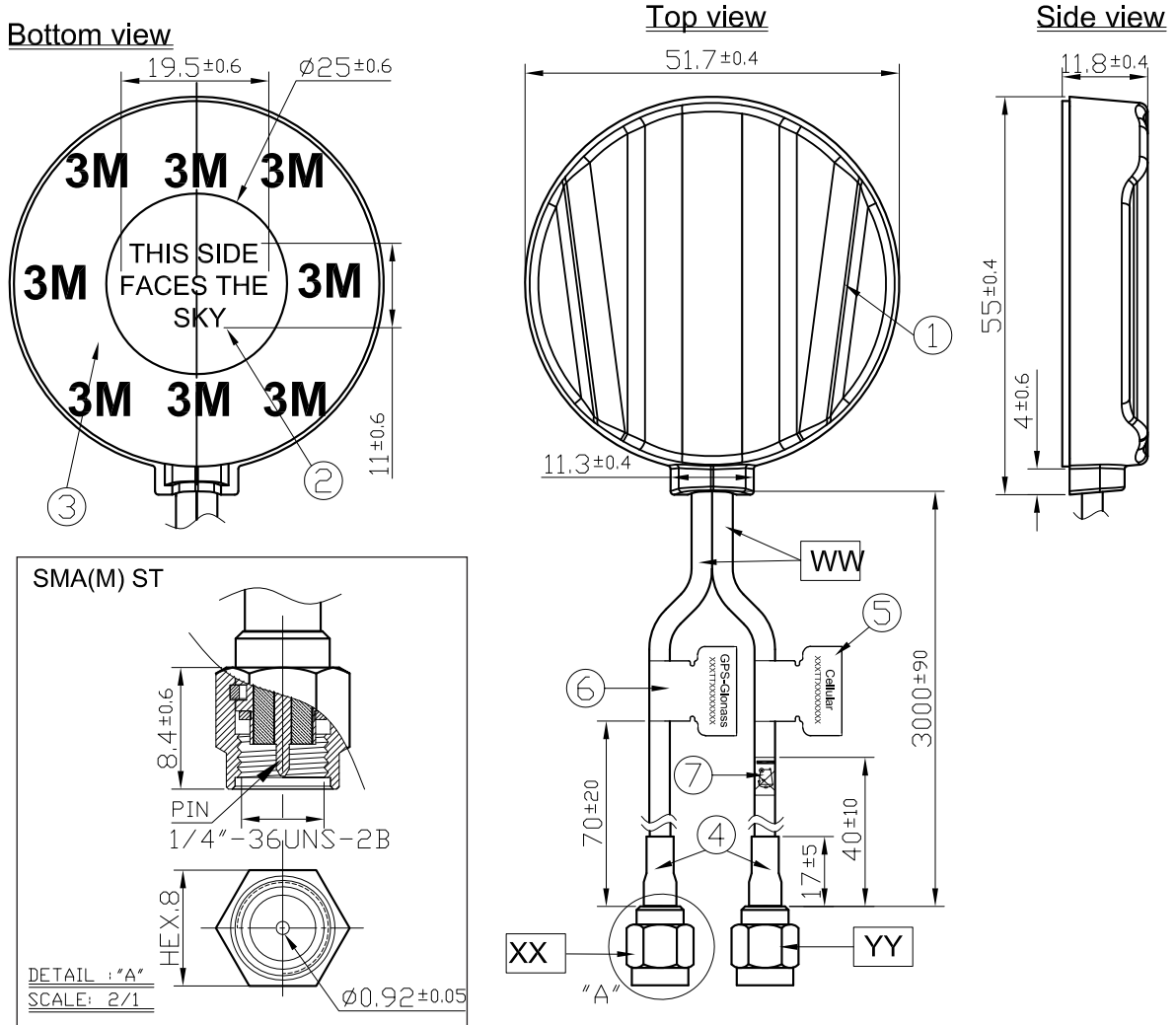

	Name	Material	Finish	QTY
1	Housing	ABS	Black	1
2	Round Label	Art Paper	White	1
3	Scotch Brand Acrylic Foam Tape	3M 4612	White Liner	1
4	Heat Shrink Tube	PE	Black	2
5	Cellular Label	Coated Paper	Blue	1
6	GPS/GLONASS Label	Coated Paper	Orange	1
7	WEEE label	Coated Paper	White	1
WW	Cable Type	RG174 Cable	Black	2
XX	Connector Type	SMA(M) ST	Nickel	1
YY	Connector Type	SMA(M) ST	Gold	1

7. Packaging

1pcs antenna per small PE bag
80 small PE bag per box

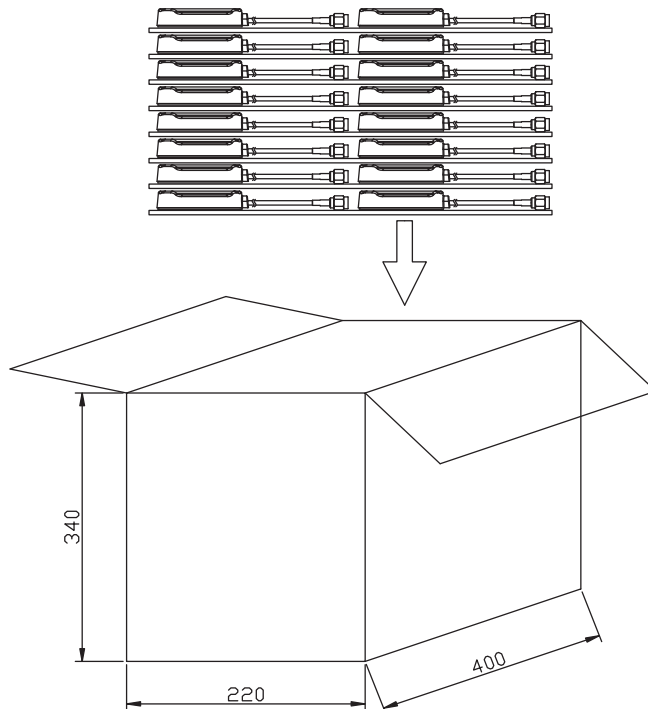
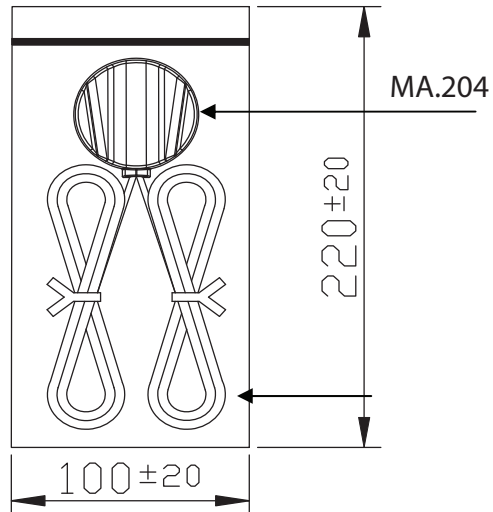

Taoglas makes no warranties based on the accuracy or completeness of the contents of this document and reserves the right to make changes to specifications and

product descriptions at any time without notice. Taoglas reserves all rights to this document and the information contained herein.

Reproduction, use or disclosure to third parties without express permission is strictly prohibited.
Copyright © 2013, Taoglas Ltd.