

**PNP/NPN COMPLEMENTARY PLANAR SILICON TRANSISTORS**

**CSA931 (PNP)  
CSC2331 (NPN)  
TO-237  
BCE**

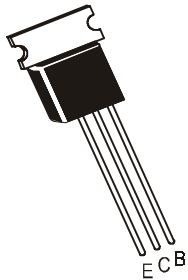

**Low Frequency Amplifier And Medium Speed Switching**

**ABSOLUTE MAXIMUM RATINGS(Ta=25deg C unless otherwise specified)**

DESCRIPTION	SYMBOL	VALUE	UNIT
Collector -Base Voltage	VCBO	80	V
Collector -Emitter Voltage	VCEO	60	V
Emitter Base Voltage	VEBO	8.0	V
Collector Current	IC	700	mA
Power Dissipation	PC	1.0	W
Operating And Storage Junction Temperature Range	Tj, Tstg	-55 to +150	deg C

**ELECTRICAL CHARACTERISTICS (Ta=25 deg C Unless Otherwise Specified)**

DESCRIPTION	SYMBOL	TEST CONDITION	MIN	TYP	MAX	UNIT
Collector -Base Voltage	VCBO	IC=100uA, IE=0	80	-	-	V
Collector -Emitter Voltage	VCEO	IC=10mA, IB=0	60	-	-	V
Emitter Base Voltage	VEBO	IE=100uA, IC=0	8.0	-	-	V
Collector Cut off Current	ICBO	VCB=60V, IE=0	-	-	100	nA
Emitter Cut off Current	IEBO	VEB=5V, IC=0	-	-	100	nA
DC Current Gain	hFE*	IC=50mA, VCE=2V	40	-	240	
Collector Emitter Saturation Voltage	VCE(Sat) *	IC=500mA, IB=50mA	-	-	0.7	V
Base Emitter Saturation Voltage	VBE(Sat) *	IC=500mA, IB=50mA	-	-	1.2	V

**Dynamic Characteristics**

Collector Output Capacitance	Cob	PNP	VCB=10V, IE=0	-	13	-	pF
		NPN	f=1MHz	-	8.0	-	pF
Transition Frequency	ft	PNP	VCE=10V, IC=50mA,	-	100	-	MHz
		NPN		30	-	-	MHz

CLASSIFICATION	R	O	Y
hFE *	40-80	70-140	120-240

\*Pulse Test : Pulse Width =350us, Duty Cycle=2%

## TO-237 Plastic Package

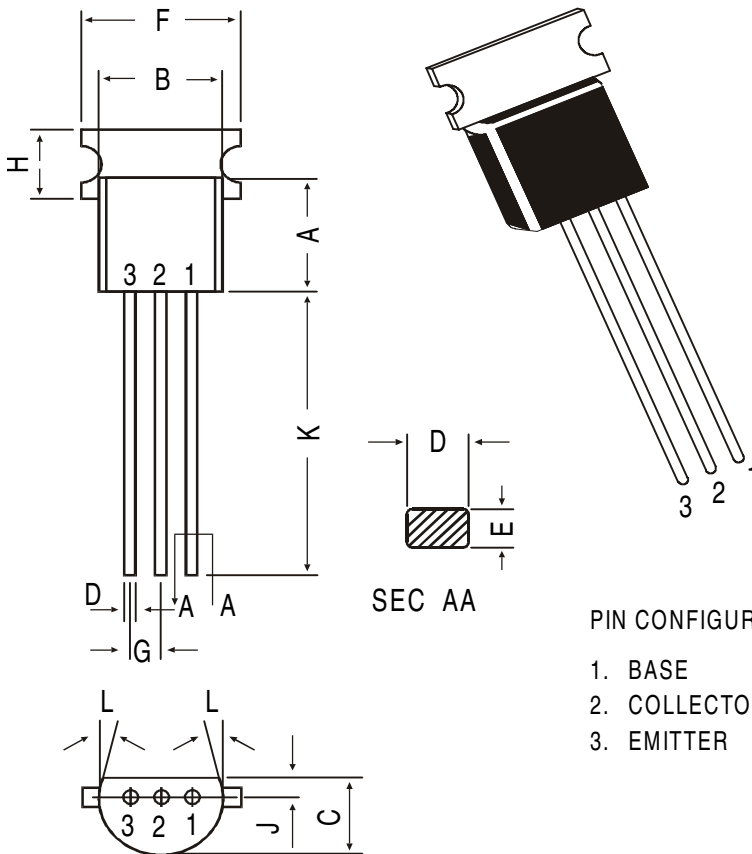

All dimensions in mm.

DIM	MIN.	MAX.
A	4.32	5.33
B	4.45	5.20
C	3.18	4.19
D	0.41	0.55
E	0.35	0.50
F	—	5.40
G	1.14	1.40
H	—	2.54
K	12.70	—
L	5 DEG	
J	1.14	1.53

### PIN CONFIGURATION

1. BASE
2. COLLECTOR
3. EMITTER

## Packing Detail

PACKAGE	STANDARD PACK		INNER CARTON BOX		OUTER CARTON BOX		
	Details	Net Weight/Qty	Size	Qty	Size	Qty	Gr Wt
TO-237 Bulk	1K/polybag	240 gm/1K pcs	3" x 7.5" x 7.5"	5.0K	17" x 15" x 13.5"	80.0K	26.2 kgs
TO-237 T&A	2K/ammo box	725 gm/2K pcs	12.5" x 8" x 1.8"	2.0K	17" x 15" x 13.5"	32.0K	13.8 kgs

## Disclaimer

The product information and the selection guides facilitate selection of the CDIL's Discrete Semiconductor Device(s) best suited for application in your product(s) as per your requirement. It is recommended that you completely review our Data Sheet(s) so as to confirm that the Device(s) meet functionality parameters for your application. The information furnished on the CDIL Web Site/CD are believed to be accurate and reliable. CDIL however, does not assume responsibility for inaccuracies or incomplete information. Furthermore, CDIL does not assume liability whatsoever, arising out of the application or use of any CDIL product; neither does it convey any license under its patent rights nor rights of others. These products are not designed for use in life saving/support appliances or systems. CDIL customers selling these products (either as individual Discrete Semiconductor Devices or incorporated in their end products), in any life saving/support appliances or systems or applications do so at their own risk and CDIL will not be responsible for any damages resulting from such sale(s).

CDIL strives for continuous improvement and reserves the right to change the specifications of its products without prior notice.



CDIL is a registered Trademark of

**Continental Device India Limited**

C-120 Naraina Industrial Area, New Delhi 110 028, India.

Telephone + 91-11-2579 6150, 5141 1112 Fax + 91-11-2579 5290, 5141 1119

email@cdil.com www.cdilsemi.com