

# SL3ICS1002/1202

## UCODE G2XM and G2XL

Rev. 3.7 — 9 October 2012  
139037

Product data sheet  
COMPANY PUBLIC

## 1. General description

---

The UHF EPCglobal Generation 2 standard allows the commercialized provision of mass adoption of UHF RFID technology for passive smart tags and labels. Main fields of applications are supply chain management and logistics for worldwide use with special consideration of European, US and Chinese frequencies to ensure that operating distances of several meters can be realized.

The G2X is a dedicated chip for passive, intelligent tags and labels supporting the EPCglobal Class 1 Generation 2 UHF RFID standard. It is especially suited for applications where operating distances of several meters and high anti-collision rates are required.

The G2X is a product out of the NXP Semiconductors UCODE product family. The entire UCODE product family offers anti-collision and collision arbitration functionality. This allows a reader to simultaneously operate multiple labels / tags within its antenna field. A UCODE G2X based label/ tag requires no external power supply.

Its contact-less interface generates the power supply via the antenna circuit by propagative energy transmission from the interrogator (reader), while the system clock is generated by an on-chip oscillator. Data transmitted from interrogator to label/tag is demodulated by the interface, and it also modulates the interrogator's electromagnetic field for data transmission from label/tag to interrogator. A label/tag can be operated without the need for line of sight or battery, as long as it is connected to a dedicated antenna for the targeted frequency range. When the label/tag is within the interrogator's operating range, the high-speed wireless interface allows data transmission in both directions.

In addition to the EPC specifications the G2X offers an integrated EAS (Electronic Article Surveillance) feature and read protection of the memory content. On top of the specification of the G2XL the G2XM offers 512-bit of user memory.



## 2. Features and benefits

---

### 2.1 Key features

- 512-bit user memory (G2XM only)
- 240-bit of EPC memory
- 64-bit tag identifier (TID) including 32-bit unique serial number
- Memory read protection
- EAS (Electronic Article Surveillance) command
- Calibrate command
- 32-bit kill password to permanently disable the tag
- 32-bit access password to allow a transition into the secured transmission state
- Broad international operating frequency: from 840 MHz to 960 MHz
- Long read/write ranges due to extremely low power design
- Reliable operation of multiple tags due to advanced anti-collision
- Forward link: 40-160 kbit/s
- Return link: 40-640 kbit/s

### 2.2 Key benefits

- High sensitivity provides long read range
- Low Q-factor for consistent performance on different materials
- Improved interference suppression for reliable operation in multi-reader environment
- Large input capacitance for ease of assembly and high assembly yield
- Highly advanced anti-collision resulting in highest identification speed
- Reliable and robust RFID technology suitable for dense reader and noisy environments

### 2.3 Custom commands

- EAS Alarm  
Enables the UHF RFID tag to be used as EAS tag without the need for a backend data base.
- Read Protect  
Protects all memory content including CRC16 from unauthorized reading.
- Calibrate  
Activates permanent back-scatter in order to evaluate the tag-to-reader performance.

### 3. Applications

- Supply chain management
- Item level tagging
- Asset management
- Container identification
- Pallet and case tracking
- Product authentication

Outside above mentioned applications, please contact NXP Semiconductors for support.

### 4. Ordering information

**Table 1. Ordering information G2XM**

Type number	Package		Version
	Name	Description	
SL3ICS1002FUG/V7AF	Wafer	Bumped die on sawn wafer	-
SL3S1002FTT	TSSOP8	plastic thin shrink small outline package; 8 leads; body width 3 mm	SOT505-1
SL3S1002FTB1	XSON3	plastic extremely thin small outline package;3 terminals; body 1 x 1.45 x 0,5 mm	SOT1122

**Table 2. Ordering information G2XL**

Type number	Package		Version
	Name	Description	
SL3ICS1202FUG/V7AF	Wafer	Bumped die on sawn wafer	-
SL3S1202FTT	TSSOP8	plastic thin shrink small outline package; 8 leads; body width 3 mm	SOT505-1
SL3S1202FTB1	XSON3	plastic extremely thin small outline package;3 terminals; body 1 x 1.45 x 0,5 mm	SOT1122

**5. Block diagram**

The SL3ICS1002/1202 IC consists of three major blocks:

- Analog RF Interface
- Digital Controller
- EEPROM

The analog part provides stable supply voltage and demodulates data received from the reader for being processed by the digital part. Further, the modulation transistor of the analog part transmits data back to the reader.

The digital section includes the state machines, processes the protocol and handles communication with the EEPROM, which contains the EPC and the user data.

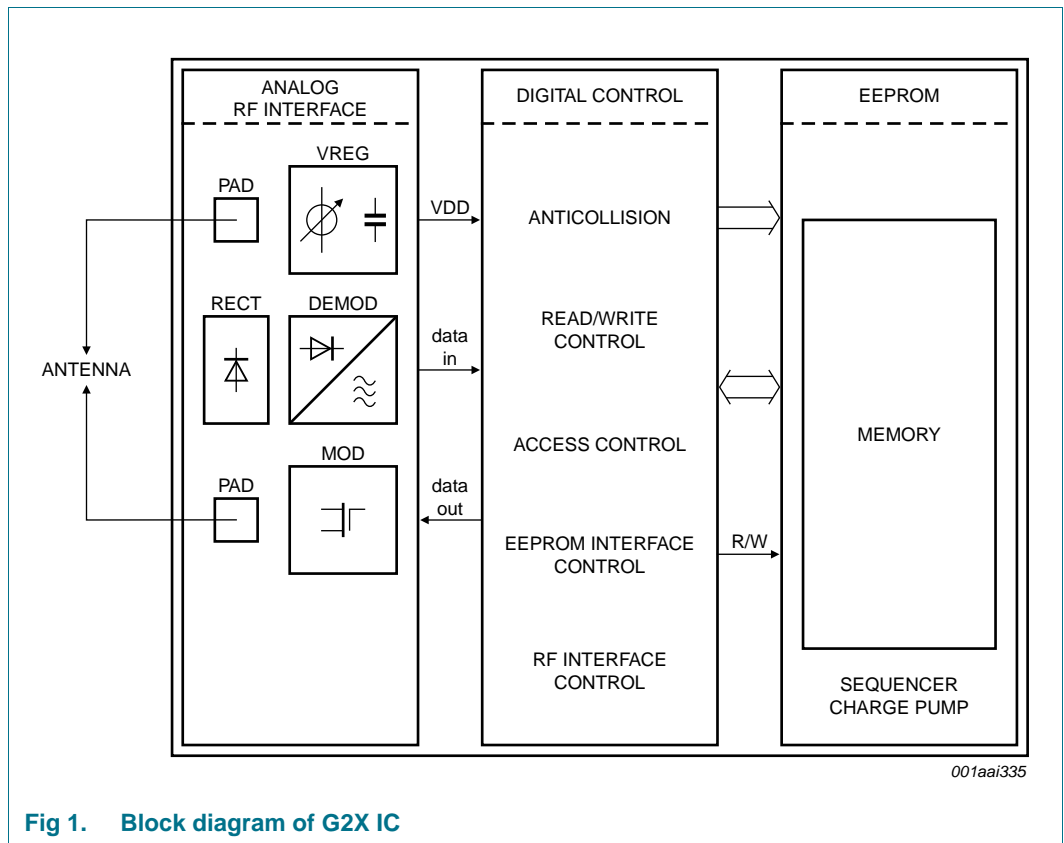

**Fig 1. Block diagram of G2X IC**

## 6. Wafer layout and pinning information

### 6.1 Wafer layout

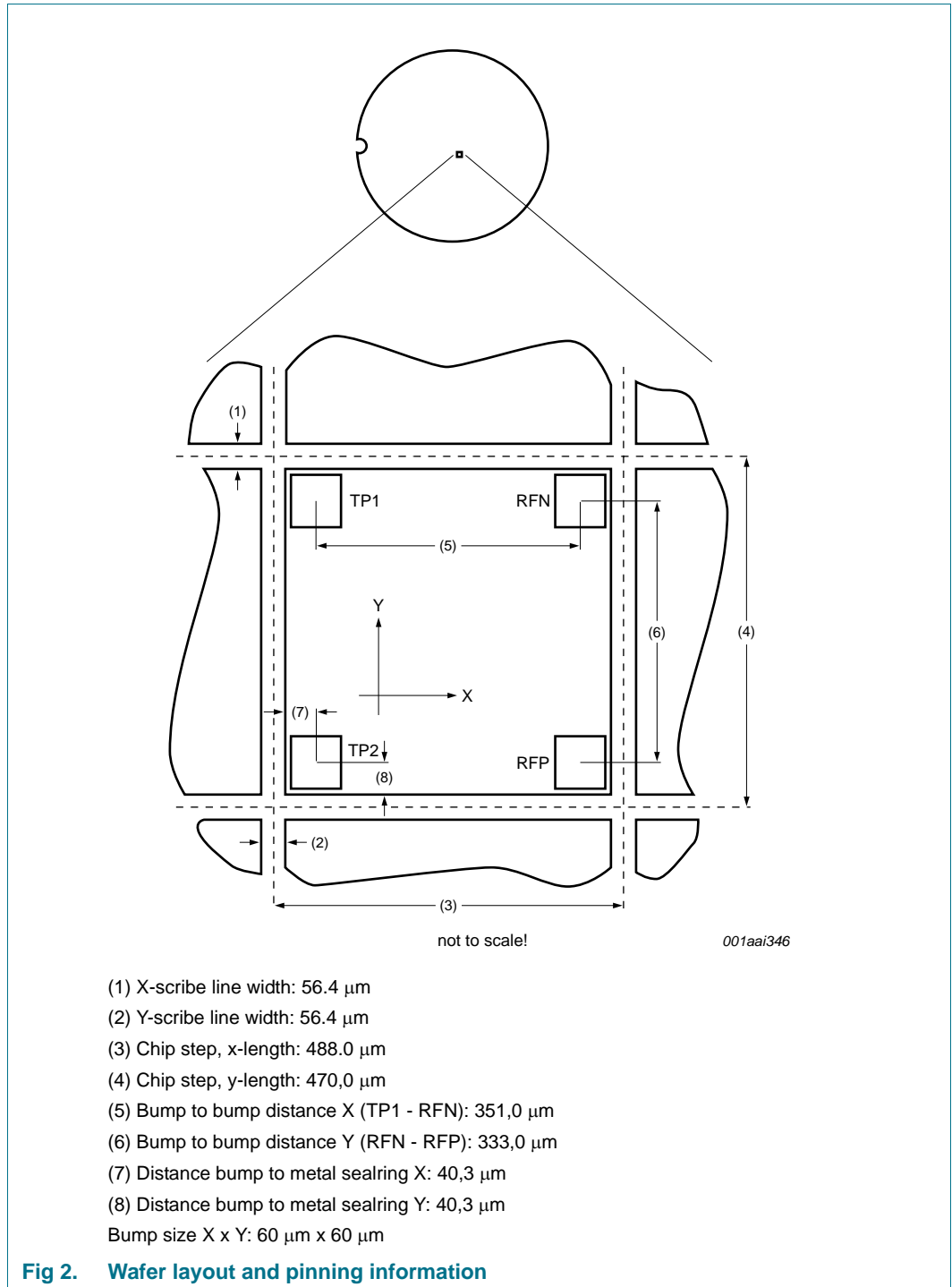

7. Package outline

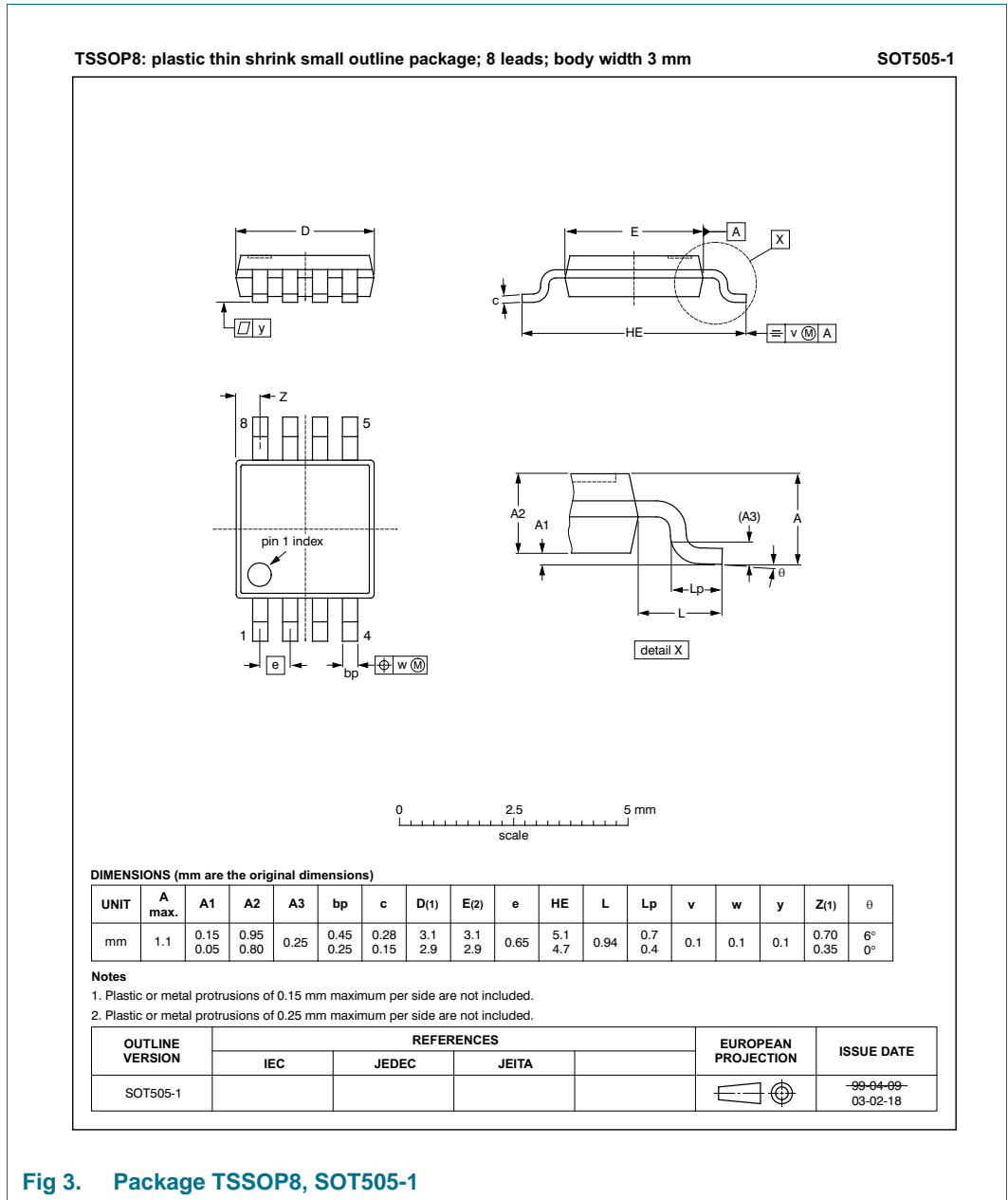

Fig 3. Package TSSOP8, SOT505-1

Table 3. Pin description of TSSOP8

Symbol	Pin	Description
RFN	1	Grounded antenna connector
-	2 to 7	Not used
RFP	8	Ungrounded antenna connector

Table 4. TSSOP8 Marking

Type	Type code (Marking)	Comment
SL3S1202FTT	SL3XL	UCODE G2XL
SL3S1002FTT	SL3XM	UCODE G2XM

XSON3: plastic extremely thin small outline package; no leads; 3 terminals; body 1 x 1.45 x 0.5 mm

SOT1122

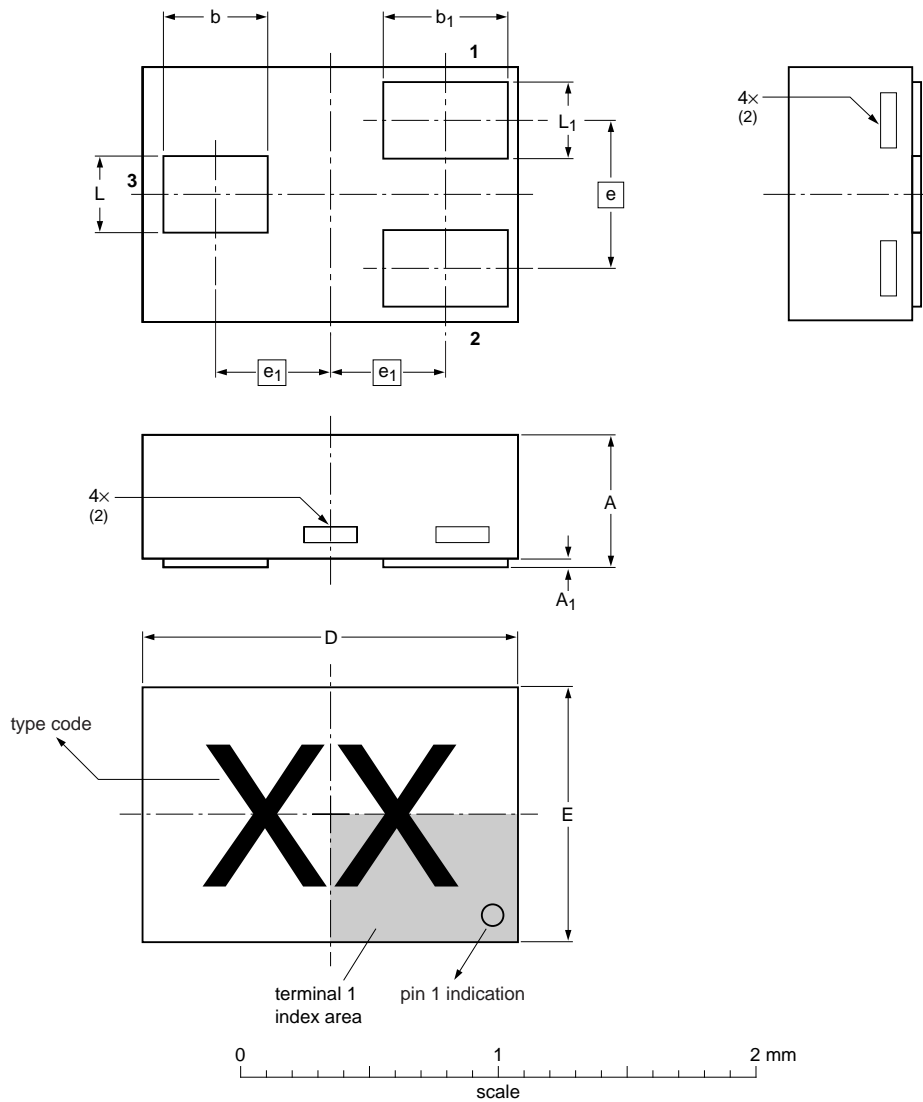

Dimensions

Unit	A <sup>(1)</sup>	A <sub>1</sub>	b	b <sub>1</sub>	D	E	e	e <sub>1</sub>	L	L <sub>1</sub>
mm	max 0.50	0.04	0.45	0.55	1.50	1.05	0.55	0.425	0.35	0.30
	nom		0.40	0.50	1.45	1.00	0.55	0.425	0.30	0.25
	min		0.37	0.47	1.40	0.95			0.27	0.22

Notes

1. Dimension A is including plating thickness.
2. Can be visible in some manufacturing processes.

sot1122\_po

Outline version	References			European projection	Issue date
	IEC	JEDEC	JEITA		
SOT1122		MO-252			09-10-09

Fig 4. Package outline SOT1122



**Table 5. Pin description of SOT1122**

Symbol	Pin	Description
RFP	1	Ungrounded antenna connector
RFN	2	Grounded antenna connector
n.c.	3	not connected

**Table 6. SOT1122 Marking**

Type	Type code (Marking)	Comment
SL3S1202FTB1	UL	UCODE G2XL
SL3S1002FTB1	UM	UCODE G2XM

## 8. Mechanical specification

### 8.1 Wafer specification

See [Ref. 20 "Data sheet - Delivery type description – General specification for 8" wafer on UV-tape with electronic fail die marking, BL-ID document number: 1093\\*\\*"](#).

#### 8.1.1 Wafer

- Designation: each wafer is scribed with batch number and wafer number
- Diameter: 200 mm (8")
- Thickness: 150  $\mu\text{m} \pm 15 \mu\text{m}$
- Number of pads 4
- Pad location: non diagonal/ placed in chip corners
- Distance pad to pad RFN-RFP 333.0  $\mu\text{m}$
- Distance pad to pad TP1-RFN: 351.0  $\mu\text{m}$
- Process: CMOS 0.14  $\mu\text{m}$
- Batch size: 25 wafers
- Dies per wafer: 120.000

#### 8.1.2 Wafer backside

- Material: Si
- Treatment: ground and stress release
- Roughness:  $R_a$  max. 0.5  $\mu\text{m}$ ,  $R_t$  max. 5  $\mu\text{m}$

#### 8.1.3 Chip dimensions

- Die size without scribe: 0.414 mm x 0.432 mm = 0.178 mm<sup>2</sup>
- Scribe line width:
  - x-dimension: 56.4  $\mu\text{m}$  (width is measured on top metal layer)
  - y-dimension: 56.4  $\mu\text{m}$  (width is measured on top metal layer)

#### 8.1.4 Passivation on front

- Type: Sandwich structure
- Material: PE-Nitride (on top)
- Thickness: 1.75  $\mu\text{m}$  total thickness of passivation

### 8.1.5 Au bump

- Bump material: > 99.9% pure Au
- Bump hardness: 35 – 80 HV 0.005
- Bump shear strength: > 70 MPa
- Bump height: 18  $\mu\text{m}$
- Bump height uniformity:
  - within a die:  $\pm 2 \mu\text{m}$
  - within a wafer:  $\pm 3 \mu\text{m}$
  - wafer to wafer:  $\pm 4 \mu\text{m}$
- Bump flatness:  $\pm 1.5 \mu\text{m}$
- Bump size:
  - RFP, RFN 60 x 60  $\mu\text{m}$
  - TP1, TP2 60 x 60  $\mu\text{m}$
  - Bump size variation:  $\pm 5 \mu\text{m}$
- Under bump metallization: sputtered TiW

### 8.1.6 Fail die identification

No inkdots are applied to the wafer.

Electronic wafer mapping (SECS II format) covers the electrical test results and additionally the results of mechanical/visual inspection.

See [Ref. 20 "Data sheet - Delivery type description – General specification for 8" wafer on UV-tape with electronic fail die marking, BL-ID document number: 1093\\*\\*"](#)

### 8.1.7 Map file distribution

See [Ref. 20 "Data sheet - Delivery type description – General specification for 8" wafer on UV-tape with electronic fail die marking, BL-ID document number: 1093\\*\\*"](#)

## 9. Limiting values

**Table 7. Limiting values**<sup>[1][2]</sup>

*In accordance with the Absolute Maximum Rating System (IEC 60134)*

*Voltages are referenced to RFN*

Symbol	Parameter	Conditions	Min	Max	Unit
<b>Die</b>					
T <sub>stg</sub>	storage temperature range		-55	+125	°C
T <sub>oper</sub>	operating temperature		-40	+85	°C
V <sub>ESD</sub>	electrostatic discharge voltage	Human body model <sup>[3]</sup>	-	± 2	kV
<b>TSSOP8, SOT1122</b>					
T <sub>stg</sub>	storage temperature range		-55	+125	°C
P <sub>tot</sub>	total power dissipation		-	30	mW
T <sub>oper</sub>	operating temperature		-40	+85	°C
V <sub>ESD</sub>	electrostatic discharge voltage	Human body model	-	± 2	kV

- [1] Stresses above those listed under Absolute Maximum Ratings may cause permanent damage to the device. This is a stress rating only and functional operation of the device at these or any conditions other than those described in the Operating Conditions and Electrical Characteristics section of this specification is not implied.
- [2] This product includes circuitry specifically designed for the protection of its internal devices from the damaging effects of excessive static charge. Nonetheless, it is suggested that conventional precautions be taken to avoid applying greater than the rated maxima.
- [3] For ESD measurement, the die chip has been mounted into a CDIP20 package.

## 10. Characteristics

### 10.1 Wafer characteristics

Table 8. Wafer characteristics

Symbol	Parameter	Conditions	Min	Typ	Max	Unit
<b>Memory characteristics</b>						
t <sub>RET</sub>	EEPROM data retention	T <sub>amb</sub> ≤ 55 °C	50	-	-	year
N <sub>WE</sub>	EEPROM write endurance	T <sub>amb</sub> ≤ 55 °C	100000	-	-	cycle
<b>Interface characteristics</b>						
P <sub>tot</sub>	total power dissipation			-	30	mW
f <sub>oper</sub>	operating frequency		840	-	960	MHz
P <sub>min</sub>	minimum operating power supply	[1][2]	-	-15	-	dBm
C <sub>i</sub>	input capacitance (parallel)	[3]	-	0.88	-	pF
Q	quality factor (Im (Z <sub>chip</sub> ) / Re (Z <sub>chip</sub> ))	[3]	-	9	-	-
Z	impedance (915 MHz)		-	22 - j195	-	Ω
-	modulated jammer suppression ≥1.0 MHz	[4]	-	- 4	-	dB
-	unmodulated jammer suppression ≥1.0 MHz	[4]	-	- 4	-	dB

[1] Power to process a Query command

[2] Measured with a 50 Ω source impedance

[3] At minimum operating power

[4] Values measured for a 40 kHz phase reversal command under matched conditions

### 10.2 Package characteristics

Table 9. Package interface characteristics

Symbol	Parameter	Conditions	Min	Typ	Max	Unit
<b>Interface characteristics SOT1122</b>						
C <sub>i</sub>	input capacitance (parallel)	[1]	-	1.02	-	pF
Z	SOT1122 impedance (915 MHz)		-	18.6 - j171.2	-	Ω
<b>Interface characteristics TSSOP8</b>						
C <sub>i</sub>	input capacitance (parallel)	[1]	-	1.16	-	pF
Z	TSSOP8 impedance (915 MHz)		-	16 - j148	-	Ω

[1] Measured with network analyzer at 915 MHz; values at 0.5 dBm after peak<sub>max</sub> of on-set of die, measured in the center of the pads.

## 11. Packing information

---

### 11.1 Wafer

See [Ref. 20 "Data sheet - Delivery type description – General specification for 8" wafer on UV-tape with electronic fail die marking, BL-ID document number: 1093\\*\\*"](#).

### 11.2 TSSOP

See <http://www.standardics.nxp.com/packaging/packing/pdf/sot505-2.t4.pdf>.

### 11.3 SOT1122

Part orientation T1. For details please refer to <http://www.standardics.nxp.com/packaging/packing/pdf/sot886.t1.t4.pdf>.

## 12. Functional description

### 12.1 Power transfer

The interrogator provides an RF field that powers the tag, equipped with a UCODE G2X. The antenna transforms the impedance of free space to the chip input impedance in order to get the maximum possible power for the G2X on the tag.

The RF field, which is oscillating on the operating frequency provided by the interrogator, is rectified to provide a smoothed DC voltage to the analog and digital modules of the IC.

The antenna that is attached to the chip may use a DC connection between the two antenna pads. Therefore the G2X also enables loop antenna design. Possible examples of supported antenna structures can be found in the reference antenna design guide.

### 12.2 Data transfer

#### 12.2.1 Reader to G2X Link

An interrogator transmits information to the UCODE G2X by modulating an RF signal in the 840 MHz - 960 MHz frequency range. The G2X receives both information and operating energy from this RF signal. Tags are passive, meaning that they receive all of their operating energy from the interrogator's RF waveform.

An interrogator is using a fixed modulation and data rate for the duration of at least an inventory round. It communicates to the G2X by modulating an RF carrier using DSB-ASK, SSB-ASK or PR-ASK with PIE encoding.

For further details refer to [Section 17](#), [Ref. 1](#), section 6.3.1.2. Interrogator-to-tag (R=>T) communications.

#### 12.2.2 G2X to reader Link

An interrogator receives information from the UCODE G2X by transmitting a continuous-wave RF signal to the tag; the G2X responds by modulating the reflection coefficient of its antenna, thereby generating modulated sidebands used to backscatter an information signal to the interrogator. The system is a reader talks first (RTF) system, meaning that a G2X modulates its antenna reflection coefficient with an information signal only after being directed by the interrogator.

G2X backscatter is a combination of ASK and PSK modulation depending on the tuning and bias point. The backscattered data is either modulated with FM0 baseband or Miller sub carrier.

For further details refer to [Section 17](#), [Ref. 1](#), section 6.3.1.3. tag-to-interrogator (T=>R) communications.

### 12.3 Operating distances

RFID tags based on the UCODE G2X silicon may achieve maximum operating distances according the following formula:

$$P_{tag} = EIRP \cdot G_{tag} \left( \frac{\lambda}{4\pi R} \right)^2 \cdot \eta \tag{1}$$

$$R_{max} = \sqrt{\frac{EIRP \cdot G_{tag} \cdot \lambda^2}{(4\pi)^2 P_{tag}}} \cdot \eta \tag{2}$$

**Table 10. Symbol description**

Symbol	Description	Unit
$P_{tag}$	minimum required RF power for the tag	W
$G_{tag}$	gain of the tag antenna	-
EIRP	transmitted RF power	m
$\lambda$	wavelength	m
$R_{max}$	maximum achieved operating distance for a $\lambda/2$ -dipole	m
$\eta$	loss factor assumed to be 0.5 considering matching and package losses	-
R	distance	m

**Table 11. Operating distances for UCODE G2X based tags and labels in released frequency bands**

Frequency range	Region	Available power	Calculated read distance single antenna <a href="#">[4]</a>	Unit
868.4 to 868.65 MHz (UHF)	Europe <a href="#">[1]</a>	0.5 W ERP	3.6	m
865.5 to 867.6 MHz (UHF)	Europe <a href="#">[2]</a>	2 W ERP	7.1	m
902 to 928 MHz (UHF)	America <a href="#">[3]</a>	4 W EIRP	7.5	m

[1] CEPT/ETSI regulations [CEPT1], [ETSI1].

[2] New CEPT/ETSI regulations. [ETSI3].

[3] FCC 47 part 15 regulation [FCC1].

[4] These read distances are maximum values for general tags and labels. Practical usable values may be lower due to damping by object materials and environmental conditions. A special tag antenna design can help achieve higher values.

The typical write range is > 50% of the read range.



## 12.4 Air interface standards

The G2X is certified according EPCglobal 1.0.9 and fully supports all parts of the "Specification for RFID Air Interface EPCglobal, EPCTM Radio-Frequency Identity Protocols, Class-1 Generation-2 UHF RFID, Protocol for Communications at 860 MHz - 960 MHz, Version 1.1.0".



95011012600000537

EPCglobal compliance and interoperability certification

## 13. Physical layer and signaling

### 13.1 Reader to G2X communication

#### 13.1.1 Physical layer

For interrogator-to-G2X link modulation refer to [Section 17](#), [Ref. 1](#), annex H.1 Baseband waveforms, modulated RF, and detected waveforms.

#### 13.1.2 Modulation

An interrogator sends information to one or more G2X by modulating an RF carrier using double-sideband amplitude shift keying (DSB-ASK), single-sideband amplitude shift keying (SSB-ASK) or phase-reversal amplitude shift keying (PR-ASK) using a pulse-interval encoding (PIE) format. The G2X receives the operating energy from this same modulated RF carrier.

[Section 17](#), [Ref. 1](#): Annex H, as well as chapter 6.3.1.2.2.

The G2X is capable of demodulating all three modulation types.

#### 13.1.3 Data encoding

The R=>T link is using PIE. For the definition of the therefore relevant reference time interval for interrogator-to-chip signaling (Tari) refer to [Section 17](#), [Ref. 1](#), chapter 6.3.1.2.3. The Tari is specified as the duration of a data-0.

#### 13.1.4 Data rates

Interrogators shall communicate using Tari values between 6.25  $\mu\text{s}$  and 25  $\mu\text{s}$ , inclusive. For interrogator compliance evaluation the preferred Tari values of 6.25  $\mu\text{s}$ , 12.5  $\mu\text{s}$  or 25  $\mu\text{s}$  should be used. For further details refer to [Section 17](#), [Ref. 1](#), chapter 6.3.1.2.4.

#### 13.1.5 RF envelope for R=>T

A specification of the relevant RF envelope parameters can be found in [Section 17](#), [Ref. 1](#), chapter 6.3.1.2.5.

#### 13.1.6 Interrogator power-up/down waveform

For a specification of the interrogator power-up and power-down RF envelope and waveform parameters refer to [Section 17](#), [Ref. 1](#), chapters 6.3.1.2.6 and 6.3.1.2.7.

#### 13.1.7 Preamble and frame-sync

An interrogator shall begin all R=>T signaling with either a preamble or a frame-sync. A preamble shall precede a Query command and denotes the start of an inventory round. For a definition and explanation of the relevant R=>T preamble and frame-sync refer to [Section 17](#), [Ref. 1](#), chapter 6.3.1.2.8.

## 13.2 G2X to reader communication

An interrogator receives information from a G2X by transmitting an unmodulated RF carrier and listening for a backscattered reply. The G2X backscatters by switching the reflection coefficient of its antenna between two states in accordance with the data being sent. For further details refer to [Section 17](#), [Ref. 1](#), chapter 6.3.1.3.

### 13.2.1 Modulation

The UCODE G2X communicates information by backscatter-modulating the amplitude and/or phase of the RF carrier. Interrogators shall be capable of demodulating either demodulation type.

### 13.2.2 Data encoding

The encoding format, selected in response to interrogator commands, is either FM0 baseband or Miller-modulated subaltern. The interrogator commands the encoding choice

#### 13.2.2.1 FM0 baseband

FM0 inverts the baseband phase at every symbol boundary; a data-0 has an additional mid-symbol phase inversion. For details on FM0 and generator state diagram, FM0 symbols and sequences and how FM0 transmissions should be terminated refer to [Section 17](#), [Ref. 1](#), chapter 6.3.1.3.

#### 13.2.2.2 FM0 Preamble

T=>R FM0 signaling begin with one of two defined preambles, depending on the value of the TRext bit specified in the Query command that initiated the inventory round. For further details refer to [Section 17](#), [Ref. 1](#), chapter 6.3.1.3.

#### 13.2.2.3 Miller-modulated sub carrier

Baseband Miller inverts its phase between two data-0s in sequence. Baseband Miller also places a phase inversion in the middle of a data-1 symbol. For details on Miller-modulated sub carrier, generator state diagram, sub carrier sequences and terminating sub carrier transmissions refer to [Section 17](#), [Ref. 1](#), chapter 6.3.1.3.

#### 13.2.2.4 Miller sub carrier preamble

T=>R sub carrier signaling begins with one of the two defined preambles. The choice depends on the value of the TRext bit specified in the Query command that initiated the inventory round. For further details refer to [Section 17](#), [Ref. 1](#), chapter 6.3.1.3.

### 13.2.3 Data rates

The G2X IC supports tag to interrogator data rates and link frequencies as specified in [Section 17](#), [Ref. 1](#), chapter 6.3.1.3.

### 13.3 Link timing

For the interrogator interacting with a UCODE G2X equipped tag population exact link and response timing requirements must be fulfilled, which can be found in [Section 17, Ref. 1](#), chapter 6.3.1.6.

#### 13.3.1 Regeneration time

The regeneration time is the time required if a G2X is to demodulate the interrogator signal, measured from the last falling edge of the last bit of the G2X response to the first falling edge of the interrogator transmission. This time is referred to as T<sub>2</sub> and can vary between 3.0 T<sub>pri</sub> and 20 T<sub>pri</sub>. For a more detailed description refer to [Section 17, Ref. 1](#), chapter 6.3.1.6.

#### 13.3.2 Start-up time

For a detailed description refer to [Section 17, Ref. 1](#), chapter 6.3.1.3.4.

#### 13.3.3 Persistence time

An interrogator chooses one of four sessions and inventories tags within that session (denoted S<sub>0</sub>, S<sub>1</sub>, S<sub>2</sub>, and S<sub>3</sub>). The interrogator and associated UCODE G2X population operate in one and only one session for the duration of an inventory round (defined above). For each session, a corresponding inventoried flag is maintained. Sessions allow tags to keep track of their inventoried status separately for each of four possible time-interleaved inventory processes, using an independent inventoried flag for each process. Two or more interrogators can use sessions to independently inventory a common UCODE G2X chip population.

A session flag indicates whether a G2X may respond to an interrogator. G2X chips maintain a separate inventoried flag for each of four sessions; each flag has symmetric A and B values. Within any given session, interrogators typically inventory tags from A to B followed by a re-inventory of tags from B back to A (or vice versa).

Additionally, the G2X has implemented a selected flag, SL, which an interrogator may assert or deassert using a Select command.

For a description of Inventoried flags S<sub>0</sub> – S<sub>3</sub> refer to [Section 17, Ref. 1](#) chapter 6.3.2.2 and for a description of the Selected flag refer to [Section 17, Ref. 1](#), chapter 6.3.2.3. For tag flags and respective persistence time refer to [Section 17, Ref. 1](#), table 6.14.

### 13.4 Bit and byte ordering

The transmission order for all R=>T and T=>R communications respects the following conventions:

- within each message, the most-significant word is transmitted first, and
- within each word, the most-significant bit (MSB) is transmitted first,

whereas one word is composed of 16 bits.

To represent memory addresses and mask lengths EBV-8 values are used. An extensible bit vector (EBV) is a data structure with an extensible data range. For a more detailed explanation refer to [Section 17, Ref. 1](#), Annex A.

### 13.5 Data integrity

The G2X ignores invalid commands. In general, "invalid" means a command that (1) is incorrect given the current the G2X state, (2) is unsupported by the G2X, (3) has incorrect parameters, (4) has a CRC error, (5) specifies an incorrect session, or (6) is in any other way not recognized or not executable by the G2X. The actual definition of "invalid" is state-specific and defined, for each G2X state, in [Section 17, Ref. 1](#) Annex B and Annex C.

All UCODE G2X backscatter error codes are summarized in [Section 17, Ref. 1](#) Error codes, Annex I. For a detailed description of the individual backscatter error situations which are command specific please refer to the [Section 17, Ref. 1](#) individual command description section 6.3.2.10.

### 13.6 CRC

A CRC-16 is a cyclic-redundancy check that an interrogator uses when protecting certain R=>T commands, and the G2X uses when protecting certain backscattered T=>R sequences. To generate a CRC-16 an interrogator or the G2X first generates the CRC-16 precursor shown in [Section 17, Ref. 1](#) Table 6.11, then take the ones-complement of the generated precursor to form the CRC-16. For a detailed description of the CRC-16 generation and handling rules refer to [Section 17, Ref. 1](#), chapter 6.3.2.1.

The CRC-5 is only used to protect the Query command (out of the mandatory command set). It is calculated out of  $X^5 + X^3 + 1$ . For a more detailed CRC-5 description refer to [Section 17, Ref. 1](#), table 6.12.

For exemplary schematic diagrams for CRC-5 and CRC-16 encoder/decoder refer to [Section 17, Ref. 1](#), Annex F.

For a CRC calculation example refer to [Section 15.1, Table 29](#) and [Table 30](#).

## 14. TAG selection, inventory and access

---

This section contains all information including commands by which a reader selects, inventories, and accesses a G2X population

An interrogator manages UCODE G2X equipped tag populations using three basic operations. Each of these operations comprises one or more commands. The operations are defined as follows

- Select:** The process by which an interrogator selects a tag population for inventory and access. Interrogators may use one or more Select commands to select a particular tag population prior to inventory.
- Inventory:** The process by which an interrogator identifies UCODE G2X equipped tags. An interrogator begins an inventory round by transmitting a Query command in one of four sessions. One or more G2X may reply. The interrogator detects a single G2X reply and requests the PC, EPC, and CRC-16 from the chip. An inventory round operates in one and only one session at a time. For an example of an interrogator inventorying and accessing a single G2X refer to [Section 17](#), [Ref. 1](#), Annex E.
- Access:** The process by which an interrogator transacts with (reads from or writes to) individual G2X. An individual G2X must be uniquely identified prior to access. Access comprises multiple commands, some of which employ one-time-pad based cover-coding of the R=>T link.

### 14.1 G2X Memory

For the general memory layout according to the standard [Section 17, Ref. 1](#), refer to Figure 6.17. The tag memory is logically subdivided into four distinct banks.

In accordance to the standard [Section 17, Ref. 1](#), section 6.3.2.1. The tag memory of the SL3ICS1002 G2XM is organized in following 4 memory sections:

**Table 12. G2X memory sections**

Name	Size	Bank
Reserved memory (32 bit ACCESS and 32 bit KILL password)	64 bit	00b
EPC (excluding 16 bit CRC-16 and 16 bit PC)	240 bit	01b
TID (including unique 32 bit serial number)	64 bit	10b
User memory (G2XM only)	512 bit	11b

The logical address of all memory banks begin at zero (00h).

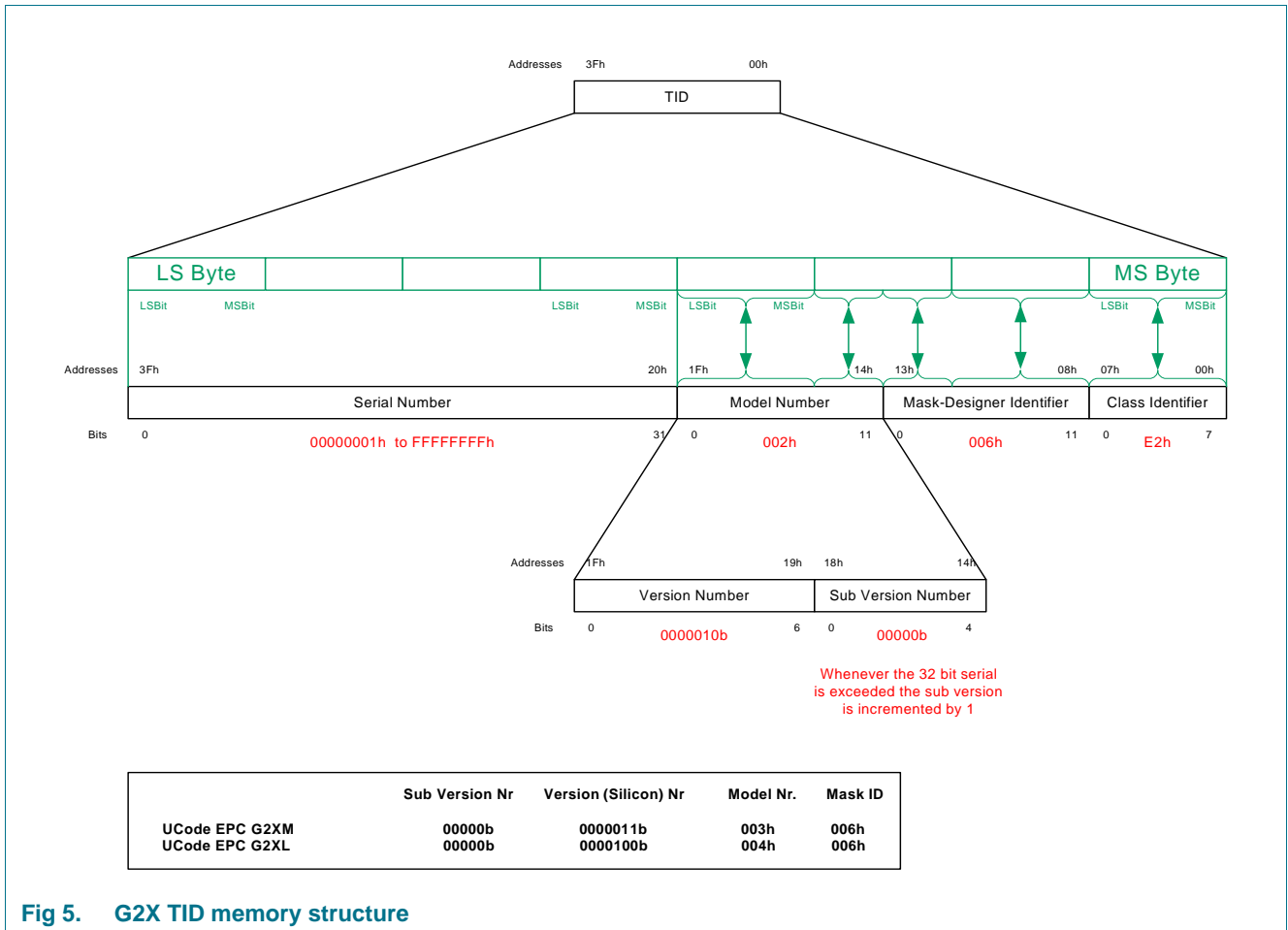

**Fig 5. G2X TID memory structure**

14.1.1 Memory map

Table 13. Memory map

Bank address	Memory address	Type	Content	Initial [1]	Remark
Bank 00	00h – 1Fh	Reserved	kill password: refer to <a href="#">Section 17</a> , <a href="#">Ref. 1</a> , chapter 6.3.2.1.1	all 00h	unlocked memory
	20h – 3Fh	Reserved	access password: refer to <a href="#">Section 17</a> , <a href="#">Ref. 1</a> , chapter 6.3.2.1.1	all 00h	unlocked memory
Bank 01	00h – 0Fh	EPC	CRC-16: refer to <a href="#">Section 17</a> , <a href="#">Ref. 1</a> , chapter 6.3.2.1.2		memory mapped calculated CRC
	10h – 14h	EPC	Backscatter length: refer to <a href="#">Section 17</a> , <a href="#">Ref. 1</a> , chapter 6.3.2.1.2	00110b	unlocked memory
	15h	EPC	Reserved for future use: refer to <a href="#">Section 17</a> , <a href="#">Ref. 1</a> , chapter 6.3.2.1.2	0b	unlocked memory
	16h	EPC	Reserved for future use: refer to <a href="#">Section 17</a> , <a href="#">Ref. 1</a> , chapter 6.3.2.1.2	0b	hardwired to 0
	17h –1Fh	EPC	Numbering system indicator: refer to <a href="#">Section 17</a> , <a href="#">Ref. 1</a> , chapter 6.3.2.1.2	00h	unlocked memory
	20h - 10Fh	EPC	EPC: refer to <a href="#">Section 17</a> , <a href="#">Ref. 1</a> , chapter 6.3.2.1.2	[2]	unlocked memory
Bank 10	00h – 07h	TID	allocation class identifier: refer to <a href="#">Section 17</a> , <a href="#">Ref. 1</a> , chapter 6.3.2.1.3	1110 0010b	locked memory
	08h – 13h	TID	tag mask designer identifier: refer to <a href="#">Section 17</a> , <a href="#">Ref. 1</a> , chapter 6.3.2.1.3	0000 0000 0110b	locked memory
	14h – 1Fh	TID	tag model number: refer to <a href="#">Section 17</a> , <a href="#">Ref. 1</a> , chapter 6.3.2.1.3	TMNR	locked memory
	20h – 3Fh	TID	serial number: refer to <a href="#">Section 17</a> , <a href="#">Ref. 1</a> , chapter 6.3.2.1.3	SNR	locked memory
Bank 11 [3]	00h – 1FFh	User	user memory: refer to <a href="#">Section 17</a> , <a href="#">Ref. 1</a> , chapter 6.3.2.1.4	undefined	unlocked memory

[1] This is the initial memory content when delivered by NXP Semiconductors

[2] G2XL: HEX 3005 FB63 AC1F 3841 EC88 0467  
G2XM: HEX 3005 FB63 AC1F 3681 EC88 0468

[3] only G2XM



#### 14.1.1.1 User memory (only G2XM)

The User Memory bank contains a sequential block of 512 bits (32 words of 16 bit) ranging from address 00h to 1Fh. The user memory can be accessed via Select, Read or Write command and it may be write locked, permanently write locked, unlocked or permanently unlocked.

In addition reading of not only of the User Memory but of the whole memory including EPC and TID can be protected by using the custom ReadProtect command.

#### 14.1.1.2 Special behavior of user memory address 1Fh

WRITE or SELECT of user memory address 1Fh will falsely set an error flag. This will affect the subsequent READ or SELECT.

**The following commands will falsely set an internal error flag (without actually causing an error):**

- 1) WRITE to user memory with WordPtr=1Fh
- 2) SELECT to user memory with compare mask ending at bitaddress 1FFh (e.g. Pointer=1FEh, length=1 or Pointer=1FDh, length=2 ...)

Note: The error flag is set independent of the chip state (also chips in the e.g. Ready state are affected).

**The falsely set error flag will affect the following sub sequential commands:**

- A) READ command with WordCount=0 → falsely responds with "memory overrun" error
- B) SELECT command with Length<>0 → falsely assumes non existing memory location

**The behavior can be avoided with:**

- Turning off the RF carrier to reset the chip (This is what readers typically do!).
- Using the READ command with WordCount<>0.
- Sending other command prior to READ or SELECT (e.g. WRITE to address<>1Fh, ReqRN) or executing READ or SELECT two times.

**Remark:** The WRITE operation itself is not affected by this problem i.e. data is written properly! With commercially available readers this behavior is typically not observed.

#### 14.1.1.3 Supported EPC types

The EPC types are defined in the EPC Tag Standards document from EPCglobal.

These standards define completely that portion of EPC tag data that is standardized, including how that data is encoded on the EPC tag itself (i.e. the EPC Tag Encodings), as well as how it is encoded for use in the information systems layers of the EPC Systems Network (i.e. the EPC URI or Uniform Resource Identifier Encodings).

The EPC Tag Encodings include a Header field followed by one or more Value Fields. The Header field indicates the length of the Values Fields and contains a numbering system identifier (NSI). The Value Fields contain a unique EPC Identifier and optional Filter Value when the latter is judged to be important to encode on the tag itself.

## 14.2 Sessions, selected and inventoried flags

Session, Selected and Inventory Flags are according the EPCglobal standard. For a description refer to [Section 17, Ref. 1](#), section 6.3.2.3.

### 14.2.1 G2X States and slot counter

For a description refer to [Section 17, Ref. 1](#), section 6.3.2.4.

### 14.2.2 G2X State Diagram

The tag state are according the EPCglobal standard please refer to: [Section 17, Ref. 1](#), section 6.3.2.4 Tag states and slot counter.

A detailed tag state diagram is shown in [Section 17, Ref. 1](#), figure 6.19. Refer also to [Section 17, Ref. 1](#), Annex B for the associated state-transition tables and to [Section 17, Ref. 1](#), Annex C for the associated command-response tables.

## 14.3 Managing tag populations

For a detailed description on how to manage an UCODE G2X tag populations refer to [Section 17, Ref. 1](#), chapter 6.3.2.6.

## 14.4 Selecting tag populations

For a detailed description of the UCODE G2X tag population selection process refer to [Section 17, Ref. 1](#), section 6.3.2.7.

## 14.5 Inventorying tag populations

For a detailed description on accessing individual tags based on the UCODE G2X refer to [Section 17, Ref. 1](#), section 6.3.2.8.

## 14.6 Accessing individual tags

For a detailed description on accessing individual tags based on the UCODE G2X refer to [Section 17, Ref. 1](#), section 6.3.2.9.

An example inventory and access of a single UCODE G2X tag is shown in [Section 17, Ref. 1](#), Annex E.1.

## 14.7 Interrogator commands and tag replies

For a detailed description refer to [Section 17, Ref. 1](#), section 6.3.2.10.

### 14.7.1 Commands

An overview of interrogator to tag commands is located in [Section 17, Ref. 1](#), Table 6.16.

Note that all mandatory commands are implemented on the G2X according to the standard. Additionally the optional command Access is supported by the G2X (for details refer to [Section 14.11 "Optional Access Command"](#)). Besides also custom commands are implemented on the G2X (for details refer to [Section 14.12 "Custom Commands"](#)).

### 14.7.2 State transition tables

The G2X responses to interrogator commands are defined by State Annex B transition tables in [Section 17, Ref. 1](#). Following states are implemented on the G2X:

- Ready, for a description refer to [Section 17, Ref. 1](#), Annex B.1.
- Arbitrate, for a description refer to [Section 17, Ref. 1](#), Annex B.2.
- Reply, for a description refer to [Section 17, Ref. 1](#), Annex B.3.
- Acknowledged, for a description refer to [Section 17, Ref. 1](#), Annex B.4.
- Open, for a description refer to [Section 17, Ref. 1](#), Annex B.5.
- Secured, for a description refer to [Section 17, Ref. 1](#), Annex B.6.
- Killed, for a description refer to [Section 17, Ref. 1](#), Annex B.7.

### 14.7.3 Command response tables

The G2X responses to interrogator commands are described in following Annex C sections of [Section 17, Ref. 1](#):

- Power-up, for a description refer to [Section 17, Ref. 1](#), Annex C.1.
- Query, for a description refer to [Section 17, Ref. 1](#), Annex C.2.
- QueryRep, for a description refer to [Section 17, Ref. 1](#), Annex C.3.
- QueryAdjust, for a description refer to [Section 17, Ref. 1](#), Annex C.4.
- ACK, for a description refer to [Section 17, Ref. 1](#), Annex C.5.
- NAK, for a description refer to [Section 17, Ref. 1](#), Annex C.6.
- Req\_RN, for a description refer to [Section 17, Ref. 1](#), Annex C.7.
- Select, for a description refer to [Section 17, Ref. 1](#), Annex C.8.
- Read, for a description refer to [Section 17, Ref. 1](#), Annex C.9.
- Write, for a description refer to [Section 17, Ref. 1](#), Annex C.10.
- Kill, for a description refer to [Section 17, Ref. 1](#), Annex C.11.
- Lock, for a description refer to [Section 17, Ref. 1](#), Annex C.12.
- Access, for a description refer to [Section 17, Ref. 1](#), Annex C.13.
- T2 time-out, for a description refer to [Section 17, Ref. 1](#), Annex C.17.
- Invalid command, for a description refer to [Section 17, Ref. 1](#), Annex C.18.

### 14.7.4 Example data-flow exchange

For data flow-exchange examples refer to [Section 17, Ref. 1](#), Annex K:

- K.1 Overview of the data-flow exchange
- K.2 Tag memory contents and lock-field values
- K.3 Data-flow exchange and command sequence

## 14.8 Mandatory Select Commands

Select commands select a particular UCODE G2X tag population based on user-defined criteria.

### 14.8.1 Select

For a detailed description of the mandatory Select command refer to [Section 17](#), [Ref. 1](#), section 6.3.2.10.

## 14.9 Mandatory Inventory Commands

Inventory commands are used to run the collision arbitration protocol.

### 14.9.1 Query

For a detailed description of the mandatory Query command refer to [Section 17](#), [Ref. 1](#), section 6.3.2.10.

### 14.9.2 QueryAdjust

For a detailed description of the mandatory QueryAdjust command refer to [Section 17](#), [Ref. 1](#), section 6.3.2.10.

### 14.9.3 QueryRep

For a detailed description of the mandatory QueryRep command refer to [Section 17](#), [Ref. 1](#), section 6.3.2.10.

### 14.9.4 ACK

For a detailed description of the mandatory ACK command refer to [Section 17](#), [Ref. 1](#), section 6.3.2.10.

### 14.9.5 NAK

For a detailed description of the mandatory NAK command refer to [Section 17](#), [Ref. 1](#), section 6.3.2.10.

## 14.10 Mandatory Access Commands

Access commands are used to read or write data from or to the G2X memory. For a detailed description of the mandatory Access command refer to [Section 17, Ref. 1](#), section 6.3.2.10.

### 14.10.1 REQ\_RN

Access commands are used to read or write data from or to the G2X memory. For a detailed description of the mandatory Access command refer to [Section 17, Ref. 1](#), section 6.3.2.10.

### 14.10.2 READ

For a detailed description of the mandatory Req\_RN command refer to [Section 17, Ref. 1](#), section 6.3.2.10.

### 14.10.3 WRITE

For a detailed description of the mandatory Write command refer to [Section 17, Ref. 1](#), section 6.3.2.10.

### 14.10.4 KILL

For a detailed description of the mandatory Kill command refer to [Section 17, Ref. 1](#), section 6.3.2.10.

### 14.10.5 LOCK

For a detailed description of the mandatory Lock command refer to [Section 17, Ref. 1](#), section 6.3.2.10.

## 14.11 Optional Access Command

### 14.11.1 Access

For a detailed description of the optional Access command refer to [Section 17, Ref. 1](#), section 6.3.2.10.

14.12 Custom Commands

14.12.1 ReadProtect

The G2X ReadProtect custom command enables reliable read protection of the entire G2X memory. Executing ReadProtect from the Secured state will set the ReadProtect-bit to '1'. With the ReadProtect-Bit set the G2X will continue to work unaffected but fail its content.

Following commands will be disabled: Read, Write, Kill, Lock, Access, ReadProtect, ChangeEAS, EAS Alarm and Calibrate. The G2X will only react upon an anticollision with Select, Query, QueryRep, QueryAdjust, ACK (no truncated reply), NAK, ReqRN but reply with zeros as EPC and CRC-16 content (except PC/password). ACK will return zeros except for the PC.

The read protection can be removed by executing Reset ReadProtect. The ReadProtect-Bit will than be cleared.

Devices whose access password is zero will ignore the command. A frame-sync must be prepended the command.

After sending the ReadProtect command an interrogator shall transmit CW for the lesser of  $T_{Reply}$  or 20 ms, where  $T_{Reply}$  is the time between the interrogator's ReadProtect command and the backscattered reply. An interrogator may observe three possible responses after sending a ReadProtect, depending on the success or failure of the operation:

- ReadProtect succeeds: After completing the ReadProtect the G2X shall backscatter the reply shown in [Table 16](#) comprising a header (a 0-bit), the tag's handle, and a CRC-16 calculated over the 0-bit and handle. Immediately after this reply the G2X will render itself to this ReadProtect mode. If the interrogator observes this reply within 20 ms then the ReadProtect completed successfully.
- The G2X encounters an error: The G2X will backscatter an error code during the CW period rather than the reply shown in the EPCglobal Spec (see Annex I for error-code definitions and for the reply format).
- ReadProtect does not succeed: If the interrogator does not observe a reply within 20 ms then the ReadProtect did not complete successfully. The interrogator may issue a Req\_RN command (containing the handle) to verify that the G2X is still in the interrogation zone, and may re-initiate the ReadProtect command.

The G2X reply to the ReadProtect command will use the extended preamble shown in EPCglobal Spec (Figure 6.11 or Figure 6.15), as appropriate (i.e. a Tag shall reply as if  $TR_{ext}=1$ ) regardless of the  $TR_{ext}$  value in the Query that initiated the round.

Table 14. ReadProtect command

	Command	RN	CRC-16
# of bits	16	16	16
description	11100000 00000001	handle	-

**Table 15. G2X reply to a successful ReadProtect procedure**

	Header	RN	CRC-16
# of bits	1	16	16
description	0	handle	-

**Table 16. ReadProtect command-response table**

Starting State	Condition	Response	Next State
ready	all	–	ready
arbitrate, reply, acknowledged	all	–	arbitrate
open	all	-	open
secured	valid handle & invalid access password	–	arbitrate
	valid handle & valid non zero access password	Backscatter handle, when done	secured
	invalid handle	–	secured
killed	all	–	killed

### 14.12.2 Reset ReadProtect

Reset ReadProtect allows an interrogator to resets the ReadProtect-bit and re-enables reading of the G2X memory content according the EPCglobal specification. The G2X will execute Reset ReadProtect from the Open or Secured states.

If a G2X in the Open or Secured states receives a Reset ReadProtect with a valid CRC-16 and a valid handle but an incorrect access password, it will not reply and transit to the Arbitrate state.

If a G2X in the Open or Secured states receives a Reset ReadProtect with a valid CRC-16 and a valid handle but the ReadProtect-Bit is not set ('0'), it will not change the ReadProtect-Bit but backscatter the reply shown in [Table 19](#).

If a G2X in the Open or Secured receives a Reset ReadProtect with a valid CRC-16 but an invalid handle, or it receives a Reset ReadProtect before which the immediately preceding command was not a Req\_RN, it will ignore the Reset ReadProtect and remain in its current state.

A frame-sync must be prepended the Reset ReadProtect command.

After sending a Reset ReadProtect an interrogator shall transmit CW for the lesser of TReply or 20 ms, where TReply is the time between the interrogator's Reset ReadProtect command and the G2X backscattered reply. An interrogator may observe three possible responses after sending a Reset ReadProtect, depending on the success or failure of the operation:

- Write succeeds: After completing the Reset ReadProtect a G2X will backscatter the reply shown in [Table 19](#) comprising a header (a 0-bit), the handle, and a CRC-16 calculated over the 0-bit and handle. If the interrogator observes this reply within 20 ms then the Reset ReadProtect completed successfully.
- The G2X encounters an error: The G2X will backscatter an error code during the CW period rather than the reply shown in [Table 19](#) (see EPCglobal Spec for error-code definitions and for the reply format).
- Write does not succeed: If the interrogator does not observe a reply within 20 ms then the Reset ReadProtect did not complete successfully. The interrogator may issue a Req\_RN command (containing the handle) to verify that the G2X is still in the interrogation zone, and may reissue the Reset ReadProtect command.

The G2X reply to the Reset ReadProtect command will use the extended preamble shown in EPCglobal Spec (Figure 6.11 or Figure 6.15), as appropriate (i.e. a G2X will reply as if T<sub>RExt</sub>=1 regardless of the T<sub>RExt</sub> value in the Query that initiated the round).

The Reset ReadProtect command is structured as following:

- 16 bit command
- Password: 32 bit Access-Password XOR with 2 times current RN16
- 16 bit handle
- CRC-16 calculate over the first command-code bit to the last handle bit



**Table 17. Reset ReadProtect command**

	Command	Password	RN	CRC-16
# of bits	16	32	16	16
description	11100000 00000010	(access password) ⊗ 2*RN16	handle	-

**Table 18. G2X reply to a successful Reset ReadProtect command**

	Header	RN	CRC-16
# of bits	1	16	16
description	0	handle	-

**Table 19. Reset ReadProtect command-response table**

Starting State	Condition	Response	Next State
ready	all	–	ready
arbitrate, reply, acknowledged	all	–	arbitrate
open	ReadProtect bit is set, valid handle & valid access password	Backscatter handle, when done	open
	ReadProtect bit is set, valid handle & invalid access password	–	arbitrate
	ReadProtect bit is set, invalid handle	–	open
	ReadProtect bit is reset	–	open
secured	ReadProtect bit is set, valid handle & valid access password	Backscatter handle, when done	secured
	ReadProtect bit is set, valid handle & invalid access password	–	arbitrate
	ReadProtect bit is set, invalid handle	–	secured
	ReadProtect bit is reset	–	secured
killed	all	–	killed

**14.12.3 ChangeEAS**

A G2X equipped RFID tag can be enhanced by a stand-alone operating EAS alarm feature. With an EAS-Alarm bit set to '1' the tag will reply to an EAS\_Alarm command by backscattering a 64 bit alarm code without the need of a Select or Query. The EAS is a built-in solution so no connection to a backend database is required. As it is a custom command no Select or Query is required to detect the EAS state enabling fast, reliable and offline article surveillance.

ChangeEAS can be executed from the Secured state only. The command will be ignored if the Access Password is zero, the command will also be ignored with an invalid CRC-16 or an invalid handle, the G2X will than remain in the current state. The CRC-16 is calculated from the first command-code bit to the last handle bit. A frame-sync must be prepended the command.

The G2X reply to a successful ChangeEAS will use the extended preamble, as appropriate (i.e. a Tag shall reply as if TRext=1) regardless of the TRext value in the Query that initiated the round.

After sending a ChangeEAS an interrogator shall transmit CW for less than TReply or 20 ms, where TReply is the time between the interrogator's ChangeEAS command and the G2X backscattered reply. An interrogator may observe three possible responses after sending a ChangeEAS, depending on the success or failure of the operation

- Write succeeds: After completing the ChangeEAS a G2X will backscatter the reply shown in [Table 22](#) comprising a header (a 0-bit), the handle, and a CRC-16 calculated over the 0-bit and handle. If the interrogator observes this reply within 20 ms then the ChangeEAS completed successfully.
- The G2X encounters an error: The G2X will backscatter an error code during the CW period rather than the reply shown in [Table 22](#) (see EPCglobal Spec for error-code definitions and for the reply format).
- Write does not succeed: If the interrogator does not observe a reply within 20 ms then the ChangeEAS did not complete successfully. The interrogator may issue a Req\_RN command (containing the handle) to verify that the G2X is still in the interrogator's field, and may reissue the ChangeEAS command.

Upon receiving a valid ChangeEAS command a G2X will perform the commanded set/reset operation of the EAS\_Alarm-Bit.

If EAS-Bit is set, the EAS\_Alarm command will be available after the next power up and reply the 64 bit EAS code upon execution. Otherwise the EAS\_Alarm command will be ignored.

**Table 20. ChangeEAS command**

	Command	ChangeEas	RN	CRC-16
# of bits	16	1	16	16
description	11100000 00000011	1 ... set EAS system bit 0 ... reset EAS system bit	handle	

**Table 21. G2X reply to a successful ChangeEAS command**

	Header	RN	CRC-16
# of bits	1	16	16
description	0	handle	-

**Table 22. ChangeEAS command-response table**

Starting State	Condition	Response	Next State
ready	all	–	ready
arbitrate, reply, acknowledged	all	–	arbitrate
open	all	–	open
secured	valid handle	Backscatter handle, when done	secured
	invalid handle	–	secured
killed	all	–	killed
Starting State	Condition	Response	Next State

**14.12.4 EAS\_Alarm**

EAS\_Alarm is a custom command causing the G2X to immediately backscatter an EAS-Alarmcode, when EAS ALARM bit is set without any delay caused by Select, Query and without the need for a backend database.

The EAS feature of the G2X is available after enabling it by sending a ChangeEAS command described in [Section 14.12.3 “ChangeEAS”](#). With an EAS-Alarm bit set to '1' the G2X will reply to an EAS\_Alarm command by backscattering a fixed 64 bit alarm code. A G2X will reply to an EAS\_Alarm command from the ready state only.

If the EAS-Alarm bit is reset ('0') by sending a ChangeEAS command in the password protected Secure state the G2X will not reply to an EAS\_Alarm command.

The EAS\_Alarm command is structured as following:

- 16 bit command
- 16 bit inverted command
- DR (TRcal divide ratio) sets the T=>R link frequency as described in EPCglobal Spec. 6.3.1.2.8 and Table 6.9.
- M (cycles per symbol) sets the T=>R data rate and modulation format as shown in EPCglobal Spec. Table 6.10.
- TRext chooses whether the T=>R preamble is prepended with a pilot tone as described in EPCglobal Spec. 6.3.1.3.

A preamble must be prepended the EAS\_Alarm command according EPCglobal Spec, 6.3.1.2.8.

Upon receiving an EAS\_Alarm command the tag loads the CRC5 register with 01001b and backscatters the 64 bit alarm code accordingly. The reader is now able to calculate the CRC5 over the backscattered 64 bits received to verify the received code.

**Table 23. EAS\_Alarm command**

	Command	Inv_Command	DR	M	TRext	CRC-16
# of bits	16	16	1	2	1	16
description	11100000 <b>00000100</b>	00011111 11111011	0: DR=8 1: DR=64/3	00: M=1 01: M=2 10: M=4 11: M=8	0: No pilot tone 1: Use pilot tone	-

**Table 24. G2X reply to a successful EAS\_Alarm command**

	Header	EAS Code
# of bits	1	64
description	0	CRC5 (MSB)

**Table 25. Eas\_Alarm command-response table**

Starting State	Condition	Response	Next State
ready	EAS-bit is set and non-zero access password	Backscatter Alarm code	ready
arbitrate, reply, acknowledged	EAS-bit is set and non-zero access password	–	arbitrate
open	EAS-bit is set and non-zero access password		open
secured	EAS-bit is set and non-zero access password		secured
killed	EAS-bit is set and non-zero access password	–	killed

### 14.12.5 Calibrate

After execution of the custom Calibrate command the G2X will continuously backscatter the user memory content in an infinite loop. The G2XL will continuously backscatter zeros. This command can be used for frequency spectrum measurements. Calibrate can only be executed from the Secure state with a non-zero Access Password set otherwise the command will be ignored.

The Calibrate command includes a CRC-16 calculated over the whole command, the handle and a prepended frame-sync.

**Table 26. Calibrate command**

	Command	RN16	CRC-16
# of bits	16	16	16
description	11100000 00000101	handle	-

**Table 27. G2X reply to a successful Calibrate command**

	Header	Infinite repeat
# of bits	1	512 (looped)
description	0	User memory data <sup>[1]</sup> zeros <sup>[2]</sup>

[1] G2XM

[2] G2XL

**Table 28. Calibrate command-response table**

Starting State	Condition	Response	Next State
ready	all	–	ready
arbitrate, reply, acknowledged	all	–	arbitrate
secured	nonzero access password	Backscatter infinite	–
	access password is zero	–	secured
killed	all	–	killed

## 15. Support information

### 15.1 CRC Calculation EXAMPLE

Old RN = 3D5Bh

Table 29. Practical example of CRC calculation for a 'Req\_RN' command by the reader

CRC Calculated @ Reader						
Cmd Code for Req_RN		F	F	F	F	
	1	F	F	F	E	
	1	F	F	F	C	
	0	E	F	D	9	
	0	C	F	9	3	
	0	8	F	0	7	
	0	0	E	2	F	
	1	1	C	5	E	
First Byte of RN						
	0	5	1	3	A	
	0	A	2	7	4	
	1	4	4	E	8	
	1	9	9	F	1	
	1	3	3	E	2	
	1	7	7	E	5	
	1	D	F	9	4	
Second Byte of RN						
	0	A	F	0	9	
	1	5	E	1	2	
	0	B	C	2	4	
	1	7	8	4	8	
	1	E	0	B	1	
	0	D	1	4	3	
	1	A	2	8	6	
	1	4	5	0	C	-> ones complement:

B	A	F	3
---	---	---	---

=> Command-Sequence: C1 3D 5B BA F3 hex

Table 30. Practical example of CRC calculation for a 'Req\_RN' command by the reader

CRC Calculated @ Tag					
Cmd Code for Req_RN		F	F	F	F
	1	F	F	F	E
	1	F	F	F	C
	0	E	F	D	9
	0	C	F	9	3
	0	8	F	0	7
	0	0	E	2	F
	0	1	C	5	E
	1	<b>2</b>	<b>8</b>	<b>9</b>	<b>9</b>
First Byte of RN	0	5	1	3	A
	0	A	2	7	4
	1	4	4	E	8
	1	9	9	F	1
	1	3	3	E	2
	1	7	7	E	5
	0	E	F	C	A
	1	<b>D</b>	<b>F</b>	<b>9</b>	<b>4</b>
Second Byte of RN	0	A	F	0	9
	1	5	E	1	2
	0	B	C	2	4
	1	7	8	4	8
	1	E	0	B	1
	0	D	1	4	3
	1	A	2	8	6
	1	<b>4</b>	<b>5</b>	<b>0</b>	<b>C</b>
First Byte of CRC	1	9	A	3	9
	0	2	4	5	3
	1	5	8	8	7
	1	A	1	2	F
	1	4	2	5	E
	0	8	4	B	C
	1	0	9	7	8
	0	<b>1</b>	<b>2</b>	<b>F</b>	<b>0</b>
Second Byte of CRC	1	3	5	C	1
	1	7	B	A	3
	1	E	7	6	7
	1	C	E	C	E
	0	8	D	B	D
	0	0	B	5	B
	1	0	6	9	7
	1	<b>1</b>	<b>D</b>	<b>0</b>	<b>F</b>

-> Residue OK



## 16. Abbreviations

**Table 31. Abbreviations**

Acronym	Description
CRC	Cyclic redundancy check
CW	Continuous wave
EEPROM	Electrically Erasable Programmable Read Only Memory
EPC	Electronic Product Code (containing Header, Domain Manager, Object Class and Serial Number)
FM0	Bi phase space modulation
G2	Generation 2
HBM	Human Body Model
IC	Integrated Circuit
LSB	Least Significant Byte/Bit
MSB	Most Significant Byte/Bit
NRZ	Non-Return to Zero coding
RF	Radio Frequency
RTF	Reader Talks First
Tari	Type A Reference Interval (ISO 18000-6)
UHF	Ultra High Frequency
X <sub>xb</sub>	Value in binary notation
XX <sub>hex</sub>	Value in hexadecimal notation

## 17. References

- [1] EPCglobal: EPC Radio-Frequency Identity Protocols Class-1 Generation-2 UHF RFID Protocol for Communications at 860 MHz – 960 MHz, Version 1.1.0 (December 17, 2005)
- [2] EPCglobal: EPC Tag Data Standards
- [3] EPCglobal (2004): FMCG RFID Physical Requirements Document (draft)
- [4] EPCglobal (2004): Class-1 Generation-2 UHF RFID Implementation Reference (draft)
- [5] European Telecommunications Standards Institute (ETSI), EN 302 208: Electromagnetic compatibility and radio spectrum matters (ERM) – Radio-frequency identification equipment operating in the band 865 MHz to 868 MHz with power levels up to 2 W, Part 1 – Technical characteristics and test methods
- [6] European Telecommunications Standards Institute (ETSI), EN 302 208: Electromagnetic compatibility and radio spectrum matters (ERM) – Radio-frequency identification equipment operating in the band 865 MHz to 868 MHz with power levels up to 2 W, Part 2 – Harmonized EN under article 3.2 of the R&TTE directive
- [7] [CEPT1]: CEPT REC 70-03 Annex 1
- [8] [ETSI1]: ETSI EN 330 220-1, 2
- [9] [ETSI3]: ETSI EN 302 208-1, 2 V<1.1.1> (2004-09-Electromagnetic compatibility And Radio spectrum Matters (ERM) Radio Frequency Identification Equipment operating in the band 865 - MHz to 868 MHz with power levels up to 2 W Part 1: Technical characteristics and test methods.
- [10] [FCC1]: FCC 47 Part 15 Section 247
- [11] ISO/IEC Directives, Part 2: Rules for the structure and drafting of International Standards
- [12] ISO/IEC 3309: Information technology – Telecommunications and information exchange between systems – High-level data link control (HDLC) procedures – Frame structure
- [13] ISO/IEC 15961: Information technology, Automatic identification and data capture – Radio frequency identification (RFID) for item management – Data protocol: application interface
- [14] ISO/IEC 15962: Information technology, Automatic identification and data capture techniques – Radio frequency identification (RFID) for item management – Data protocol: data encoding rules and logical memory functions
- [15] ISO/IEC 15963: Information technology — Radio frequency identification for item management — Unique identification for RF tags
- [16] ISO/IEC 18000-1: Information technology — Radio frequency identification for item management — Part 1: Reference architecture and definition of parameters to be standardized
- [17] ISO/IEC 18000-6: Information technology automatic identification and data capture techniques — Radio frequency identification for item management air interface — Part 6: Parameters for air interface communications at 860–960 MHz
- [18] ISO/IEC 19762: Information technology AIDC techniques – Harmonized vocabulary – Part 3: radio-frequency identification (RFID)

- [19] U.S. Code of Federal Regulations (CFR), Title 47, Chapter I, Part 15: Radio-frequency devices, U.S. Federal Communications Commission.
- [20] **Data sheet** - Delivery type description – General specification for 8" wafer on UV-tape with electronic fail die marking, BL-ID document number: 1093\*\*1

---

1. \*\* ... document version number

## 18. Revision history

**Table 32. Revision history**

Document ID	Release date	Data sheet status	Change notice	Supersedes
SL3ICS1002_1202 v.3.7	20121009	Product data sheet	-	139036
Modifications:	<ul style="list-style-type: none"> <li>Update of the delivery form</li> </ul>			
139036	20110310	Product data sheet		139035
Modifications:	<ul style="list-style-type: none"> <li><a href="#">Table 4 "TSSOP8 Marking"</a>: added</li> <li><a href="#">Section 14.1.1.2 "Special behavior of user memory address 1Fh"</a>: added</li> </ul>			
139035	20091102	Product data sheet		139034
Modifications:	<ul style="list-style-type: none"> <li>Type SOT1122 added</li> <li><a href="#">Figure 2 "Wafer layout and pinning information"</a>: correction of drawing</li> </ul>			
139034	20090721	Product data sheet		139033
Modifications:	<ul style="list-style-type: none"> <li><a href="#">Table 11 "TSSOP8 characteristics"</a> and <a href="#">Table 9 "Package interface characteristics"</a>: removed "Memory characteristics"</li> </ul>			
139033	20090605	Product data sheet	-	139032 139132
Modifications:	<ul style="list-style-type: none"> <li>This data sheet is a combination of data sheets SL3ICS1002 and SL3ICS1202</li> <li>New type FCS2 Aluminum, SOT1040AB2 added</li> <li><a href="#">Section 8.1.6 "Fail die identification"</a>: added</li> <li><a href="#">Section 11 "Packing information"</a>: edited</li> </ul>			
139032	20080716	Product data sheet		139031
Modifications:	<ul style="list-style-type: none"> <li>rephrasing of <a href="#">Section 2 "Features and benefits" on page 2</a></li> <li>added "calibrate command" in <a href="#">Section 2 "Features and benefits" on page 2</a></li> <li>redesign of <a href="#">Figure 1 "Block diagram of G2X IC" on page 4</a></li> <li>merging of Fig. 2 Pinning and Fig. 3 Wafer layout - see <a href="#">Figure 2 "Wafer layout and pinning information" on page 5</a></li> <li>added type "FCS2 Polymer Strap - SOT1040AA1" in <a href="#">Section 4 "Ordering information"</a>, <a href="#">Section 6 "Wafer layout and pinning information"</a>, <a href="#">Section 7 "Package outline"</a>, <a href="#">Section 8 "Mechanical specification"</a>, <a href="#">Section 9 "Limiting values"</a>, <a href="#">Section 10 "Characteristics"</a></li> <li>added <a href="#">Section 11 "Handling information for Flip Chip Strap (FCS2, SOT1040)" on page 19</a></li> <li>added <a href="#">Section 11 "Packing information" on page 14</a></li> <li>added <a href="#">Table 10 "Symbol description" on page 16</a></li> <li>correction of <a href="#">Table 13 "Memory map" on page 24</a></li> <li>removed "ongoing" in 32 bit ongoing in <a href="#">Section 2.1</a> and <a href="#">Table 12 "G2X memory sections"</a></li> </ul>			
139031	20080428	Product data sheet		139030

Table 32. Revision history ...continued

Document ID	Release date	Data sheet status	Change notice	Supersedes
Modifications:	<ul style="list-style-type: none"> <li>• update of <a href="#">Table 1 “Ordering information” on page 3</a></li> <li>• added <a href="#">Section 7 “Package outline” on page 6</a></li> <li>• added <a href="#">Section 8.1.7 “Map file distribution” on page 11</a></li> <li>• added <a href="#">Table 9 “Limiting values TSSOP8 [1][2]” on page 14</a></li> <li>• added room temperature in <a href="#">Table 11 “Memory characteristics” on page 15</a></li> <li>• added <a href="#">Section 10.2 “TSSOP8 characteristics” on page 17</a></li> <li>• update of the “EPCglobal compliance and interoperability certification” in <a href="#">Section 12.4 “Air interface standards” on page 17</a></li> <li>• correction of “(excluding 16 bit CRC-16 and 16 bit PC) in <a href="#">Table 12 “G2X memory sections” on page 23</a></li> <li>• correction of Initials in “tag mask designer” in <a href="#">Table 13 “Memory map” on page 24</a></li> <li>• removed the sentence “The ChangeEAS custom command will toggle the state of the EAS-Alarm bit located in the EEprom” in <a href="#">Section 14.12.3 “ChangeEAS” on page 34</a>.</li> <li>• added description of ChangeEAS in <a href="#">Table 20 “ChangeEAS command” on page 34</a></li> </ul>			
139030	20071221	Product data sheet	-	139011
Modifications:	<ul style="list-style-type: none"> <li>• change of product status</li> <li>• general update</li> </ul>			
139011	20070910	Objective data sheet	-	139010
Modifications:	<ul style="list-style-type: none"> <li>• removed double section Change EAS, EAS Alarm, Chapter 12.11.7</li> <li>• changed “Reader” to “Tag”</li> </ul>			
139010	20070612	Objective data sheet	-	-
	<ul style="list-style-type: none"> <li>• initial version</li> </ul>			

## 19. Legal information

### 19.1 Data sheet status

Document status <sup>[1][2]</sup>	Product status <sup>[3]</sup>	Definition
Objective [short] data sheet	Development	This document contains data from the objective specification for product development.
Preliminary [short] data sheet	Qualification	This document contains data from the preliminary specification.
Product [short] data sheet	Production	This document contains the product specification.

[1] Please consult the most recently issued document before initiating or completing a design.

[2] The term 'short data sheet' is explained in section "Definitions".

[3] The product status of device(s) described in this document may have changed since this document was published and may differ in case of multiple devices. The latest product status information is available on the Internet at URL <http://www.nxp.com>.

### 19.2 Definitions

**Draft** — The document is a draft version only. The content is still under internal review and subject to formal approval, which may result in modifications or additions. NXP Semiconductors does not give any representations or warranties as to the accuracy or completeness of information included herein and shall have no liability for the consequences of use of such information.

**Short data sheet** — A short data sheet is an extract from a full data sheet with the same product type number(s) and title. A short data sheet is intended for quick reference only and should not be relied upon to contain detailed and full information. For detailed and full information see the relevant full data sheet, which is available on request via the local NXP Semiconductors sales office. In case of any inconsistency or conflict with the short data sheet, the full data sheet shall prevail.

**Product specification** — The information and data provided in a Product data sheet shall define the specification of the product as agreed between NXP Semiconductors and its customer, unless NXP Semiconductors and customer have explicitly agreed otherwise in writing. In no event however, shall an agreement be valid in which the NXP Semiconductors product is deemed to offer functions and qualities beyond those described in the Product data sheet.

### 19.3 Disclaimers

**Limited warranty and liability** — Information in this document is believed to be accurate and reliable. However, NXP Semiconductors does not give any representations or warranties, expressed or implied, as to the accuracy or completeness of such information and shall have no liability for the consequences of use of such information. NXP Semiconductors takes no responsibility for the content in this document if provided by an information source outside of NXP Semiconductors.

In no event shall NXP Semiconductors be liable for any indirect, incidental, punitive, special or consequential damages (including - without limitation - lost profits, lost savings, business interruption, costs related to the removal or replacement of any products or rework charges) whether or not such damages are based on tort (including negligence), warranty, breach of contract or any other legal theory.

Notwithstanding any damages that customer might incur for any reason whatsoever, NXP Semiconductors' aggregate and cumulative liability towards customer for the products described herein shall be limited in accordance with the *Terms and conditions of commercial sale* of NXP Semiconductors.

**Right to make changes** — NXP Semiconductors reserves the right to make changes to information published in this document, including without limitation specifications and product descriptions, at any time and without notice. This document supersedes and replaces all information supplied prior to the publication hereof.

**Suitability for use** — NXP Semiconductors products are not designed, authorized or warranted to be suitable for use in life support, life-critical or safety-critical systems or equipment, nor in applications where failure or malfunction of an NXP Semiconductors product can reasonably be expected to result in personal injury, death or severe property or environmental damage. NXP Semiconductors and its suppliers accept no liability for inclusion and/or use of NXP Semiconductors products in such equipment or applications and therefore such inclusion and/or use is at the customer's own risk.

**Applications** — Applications that are described herein for any of these products are for illustrative purposes only. NXP Semiconductors makes no representation or warranty that such applications will be suitable for the specified use without further testing or modification.

Customers are responsible for the design and operation of their applications and products using NXP Semiconductors products, and NXP Semiconductors accepts no liability for any assistance with applications or customer product design. It is customer's sole responsibility to determine whether the NXP Semiconductors product is suitable and fit for the customer's applications and products planned, as well as for the planned application and use of customer's third party customer(s). Customers should provide appropriate design and operating safeguards to minimize the risks associated with their applications and products.

NXP Semiconductors does not accept any liability related to any default, damage, costs or problem which is based on any weakness or default in the customer's applications or products, or the application or use by customer's third party customer(s). Customer is responsible for doing all necessary testing for the customer's applications and products using NXP Semiconductors products in order to avoid a default of the applications and the products or of the application or use by customer's third party customer(s). NXP does not accept any liability in this respect.

**Limiting values** — Stress above one or more limiting values (as defined in the Absolute Maximum Ratings System of IEC 60134) will cause permanent damage to the device. Limiting values are stress ratings only and (proper) operation of the device at these or any other conditions above those given in the Recommended operating conditions section (if present) or the Characteristics sections of this document is not warranted. Constant or repeated exposure to limiting values will permanently and irreversibly affect the quality and reliability of the device.

**Terms and conditions of commercial sale** — NXP Semiconductors products are sold subject to the general terms and conditions of commercial sale, as published at <http://www.nxp.com/profile/terms>, unless otherwise agreed in a valid written individual agreement. In case an individual agreement is concluded only the terms and conditions of the respective agreement shall apply. NXP Semiconductors hereby expressly objects to applying the customer's general terms and conditions with regard to the purchase of NXP Semiconductors products by customer.

**No offer to sell or license** — Nothing in this document may be interpreted or construed as an offer to sell products that is open for acceptance or the grant, conveyance or implication of any license under any copyrights, patents or other industrial or intellectual property rights.

**Export control** — This document as well as the item(s) described herein may be subject to export control regulations. Export might require a prior authorization from competent authorities.

**Quick reference data** — The Quick reference data is an extract of the product data given in the Limiting values and Characteristics sections of this document, and as such is not complete, exhaustive or legally binding.

**Non-automotive qualified products** — Unless this data sheet expressly states that this specific NXP Semiconductors product is automotive qualified, the product is not suitable for automotive use. It is neither qualified nor tested in accordance with automotive testing or application requirements. NXP Semiconductors accepts no liability for inclusion and/or use of non-automotive qualified products in automotive equipment or applications.

In the event that customer uses the product for design-in and use in automotive applications to automotive specifications and standards, customer (a) shall use the product without NXP Semiconductors' warranty of the product for such automotive applications, use and specifications, and (b)

whenever customer uses the product for automotive applications beyond NXP Semiconductors' specifications such use shall be solely at customer's own risk, and (c) customer fully indemnifies NXP Semiconductors for any liability, damages or failed product claims resulting from customer design and use of the product for automotive applications beyond NXP Semiconductors' standard warranty and NXP Semiconductors' product specifications.

**Translations** — A non-English (translated) version of a document is for reference only. The English version shall prevail in case of any discrepancy between the translated and English versions.

## 19.4 Trademarks

Notice: All referenced brands, product names, service names and trademarks are the property of their respective owners.

**UCODE** — is a trademark of NXP B.V.

## 20. Contact information

For more information, please visit: <http://www.nxp.com>

For sales office addresses, please send an email to: [salesaddresses@nxp.com](mailto:salesaddresses@nxp.com)

## 21. Tables

Table 1.	Ordering information G2XM	3
Table 2.	Ordering information G2XL	3
Table 3.	Pin description of TSSOP8	6
Table 4.	TSSOP8 Marking	7
Table 5.	Pin description of SOT1122	9
Table 6.	SOT1122 Marking	9
Table 7.	Limiting values <sup>[1][2]</sup>	12
Table 8.	Wafer characteristics	13
Table 9.	Package interface characteristics	13
Table 10.	Symbol description	16
Table 11.	Operating distances for UCODE G2X based tags and labels in released frequency bands	16
Table 12.	G2X memory sections	23
Table 13.	Memory map	24
Table 14.	ReadProtect command	30
Table 15.	G2X reply to a successful ReadProtect procedure	31
Table 16.	ReadProtect command-response table	31
Table 17.	Reset ReadProtect command	33
Table 18.	G2X reply to a successful Reset ReadProtect command	33
Table 19.	Reset ReadProtect command-response table	33
Table 20.	ChangeEAS command	34
Table 21.	G2X reply to a successful ChangeEAS command	35
Table 22.	ChangeEAS command-response table	35
Table 23.	EAS_Alarm command	36
Table 24.	G2X reply to a successful EAS_Alarm command	36
Table 25.	Eas_Alarm command-response table	37
Table 26.	Calibrate command	38
Table 27.	G2X reply to a successful Calibrate command	38
Table 28.	Calibrate command-response table	38
Table 29.	Practical example of CRC calculation for a 'Req_RN' command by the reader	39
Table 30.	Practical example of CRC calculation for a 'Req_RN' command by the reader	40
Table 31.	Abbreviations	41
Table 32.	Revision history	44



---

## 22. Figures

---

Fig 1.	Block diagram of G2X IC . . . . .	4
Fig 2.	Wafer layout and pinning information . . . . .	5
Fig 3.	Package TSSOP8, SOT505-1 . . . . .	6
Fig 4.	Package outline SOT1122 . . . . .	8
Fig 5.	G2X TID memory structure . . . . .	23

## 23. Contents

<b>1</b>	<b>General description</b> . . . . .	<b>1</b>	13.2.1	Modulation	19
<b>2</b>	<b>Features and benefits</b> . . . . .	<b>2</b>	13.2.2	Data encoding	19
2.1	Key features	2	13.2.2.1	FM0 baseband	19
2.2	Key benefits	2	13.2.2.2	FM0 Preamble	19
2.3	Custom commands	2	13.2.2.3	Miller-modulated sub carrier	19
<b>3</b>	<b>Applications</b> . . . . .	<b>3</b>	13.2.2.4	Miller sub carrier preamble	19
<b>4</b>	<b>Ordering information</b> . . . . .	<b>3</b>	13.2.3	Data rates	19
<b>5</b>	<b>Block diagram</b> . . . . .	<b>4</b>	13.3	Link timing	20
<b>6</b>	<b>Wafer layout and pinning information</b> . . . . .	<b>5</b>	13.3.1	Regeneration time	20
6.1	Wafer layout	5	13.3.2	Start-up time	20
<b>7</b>	<b>Package outline</b> . . . . .	<b>6</b>	13.3.3	Persistence time	20
<b>8</b>	<b>Mechanical specification</b> . . . . .	<b>10</b>	13.4	Bit and byte ordering	20
8.1	Wafer specification	10	13.5	Data integrity	21
8.1.1	Wafer	10	13.6	CRC	21
8.1.2	Wafer backside	10	<b>14</b>	<b>TAG selection, inventory and access</b>	<b>22</b>
8.1.3	Chip dimensions	10	14.1	G2X Memory	23
8.1.4	Passivation on front	10	14.1.1	Memory map	24
8.1.5	Au bump	11	14.1.1.1	User memory (only G2XM)	25
8.1.6	Fail die identification	11	14.1.1.2	Special behavior of user memory address 1Fh	25
8.1.7	Map file distribution	11	14.1.1.3	Supported EPC types	25
<b>9</b>	<b>Limiting values</b> . . . . .	<b>12</b>	14.2	Sessions, selected and inventoried flags	26
<b>10</b>	<b>Characteristics</b> . . . . .	<b>13</b>	14.2.1	G2X States and slot counter	26
10.1	Wafer characteristics	13	14.2.2	G2X State Diagram	26
10.2	Package characteristics	13	14.3	Managing tag populations	26
<b>11</b>	<b>Packing information</b> . . . . .	<b>14</b>	14.4	Selecting tag populations	26
11.1	Wafer	14	14.5	Inventoried tag populations	26
11.2	TSSOP	14	14.6	Accessing individual tags	26
11.3	SOT1122	14	14.7	Interrogator commands and tag replies	26
<b>12</b>	<b>Functional description</b> . . . . .	<b>15</b>	14.7.1	Commands	26
12.1	Power transfer	15	14.7.2	State transition tables	27
12.2	Data transfer	15	14.7.3	Command response tables	27
12.2.1	Reader to G2X Link	15	14.7.4	Example data-flow exchange	27
12.2.2	G2X to reader Link	15	14.8	Mandatory Select Commands	27
12.3	Operating distances	16	14.8.1	Select	28
12.4	Air interface standards	17	14.9	Mandatory Inventory Commands	28
<b>13</b>	<b>Physical layer and signaling</b> . . . . .	<b>18</b>	14.9.1	Query	28
13.1	Reader to G2X communication	18	14.9.2	QueryAdjust	28
13.1.1	Physical layer	18	14.9.3	QueryRep	28
13.1.2	Modulation	18	14.9.4	ACK	28
13.1.3	Data encoding	18	14.9.5	NAK	28
13.1.4	Data rates	18	14.10	Mandatory Access Commands	29
13.1.5	RF envelope for R=>T	18	14.10.1	REQ_RN	29
13.1.6	Interrogator power-up/down waveform	18	14.10.2	READ	29
13.1.7	Preamble and frame-sync	18	14.10.3	WRITE	29
13.2	G2X to reader communication	19	14.10.4	KILL	29
			14.10.5	LOCK	29
			14.11	Optional Access Command	29
			14.11.1	Access	29

continued >>

14.12 Custom Commands ..... 30

14.12.1 ReadProtect ..... 30

14.12.2 Reset ReadProtect ..... 32

14.12.3 ChangeEAS ..... 34

14.12.4 EAS\_Alarm ..... 36

14.12.5 Calibrate ..... 38

**15 Support information ..... 39**

15.1 CRC Calculation EXAMPLE ..... 39

**16 Abbreviations ..... 41**

**17 References ..... 42**

**18 Revision history ..... 44**

**19 Legal information ..... 46**

19.1 Data sheet status ..... 46

19.2 Definitions ..... 46

19.3 Disclaimers ..... 46

19.4 Trademarks ..... 47

**20 Contact information ..... 47**

**21 Tables ..... 48**

**22 Figures ..... 49**

**23 Contents ..... 50**

---

Please be aware that important notices concerning this document and the product(s) described herein, have been included in section 'Legal information'.

---

© NXP B.V. 2012.

All rights reserved.

For more information, please visit: <http://www.nxp.com>

For sales office addresses, please send an email to: [salesaddresses@nxp.com](mailto:salesaddresses@nxp.com)

Date of release: 9 October 2012  
139037