

1310/1490/1555nm Integrated Triplexer Transceiver

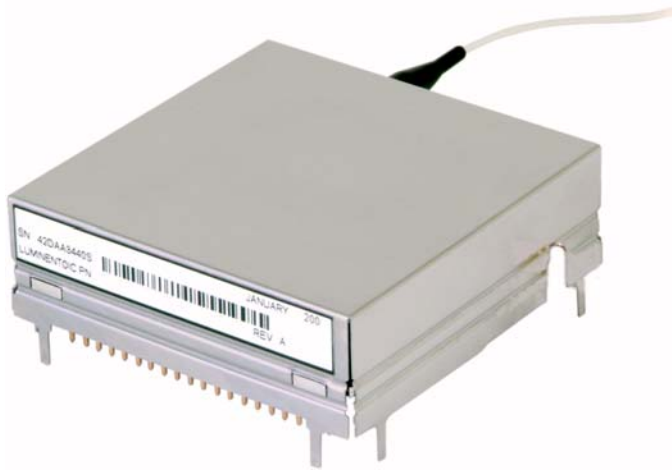

Features

- Single fiber, integrated triplexer transceiver
- Compliant to FSAN G.984.2 specifications
- Voice/Data/Video FTTx ONT/ONU applications
- 1310nm Tx, 1490nm Rx, 1555nm video Rx
- 1244Mbps Tx / 2488Mbps Rx asymmetric data rate
- Burst mode upstream transmission
- 19dBmV minimum RF output power (with mixed GPON channel plan)
- 870MHz Video Bandwidth
- -40 to 85°C Case Operation
- Feedback Video AGC Operation
- 20km reach
- 28dB power budget

- **Digital Transmitter:** A DFB laser diode is employed for upstream transmission at OC-24 (1244Mbps). The optical transmitter includes a back facet photodetector to monitor laser power for APC control.

- **Digital Receiver:** An APD with TIA is employed for downstream data reception at OC-48 (2488Mbps). A post amplifier is also included for CML output compatibility.

- **Analog Receiver:** 870MHz forward path video (CATV) receiver with multiple gain stages, automatic gain control (AGC), and status indicators.

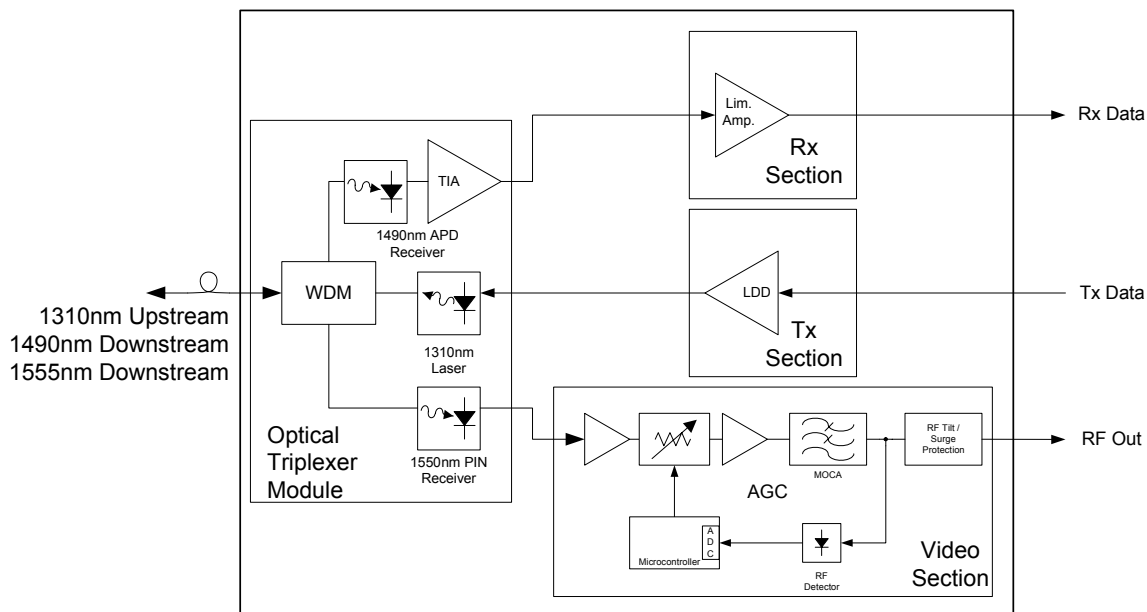

Triplexer Block Diagram

Absolute Maximum Ratings

Usage of this transceiver shall adhere to the following absolute maximum ratings. Stresses beyond those in Table 1 may cause permanent damage to the unit. These are stress ratings only, and functional operation of the unit at these or any other conditions beyond those indicated in the operational sections of the specifications is not implied. Exposure to absolute maximum rating conditions for extended periods may affect unit reliability.

Table 1 - Absolute Maximum Ratings

Parameter	Minimum	Maximum	Unit/Conditions
Ambient Storage Temperature	-40	85	°C
Operating Case Temperature	-40	85	°C
Operating Case Humidity Range	10%	90%	non-condensing
ESD Sensitivity (Human Body Model)	-	1000	V
Lead Soldering Temperature	-	260°C	10 sec
Vdd_+12V	-	15	V
Vcc_Rx	-0.4	+4.2	V
Vcc_Tx	-0.4	Vcc_Rx + 1	V
Vcc_μC	-0.4	+4.2	V

Module Characteristics

Table 2 - Module Characteristics

Parameter	Minimum	Typical	Maximum	Unit/Conditions
1555nm external to 1490 nm Rx Isolation	32	-	-	dB
1490nm external to 1555nm Rx Isolation	32	-	-	dB
1310nm external to 1555nm Video Isolation	40	-	-	dB
1310nm external to 1490nm data Isolation	30	-	-	dB
1310nm Tx to 1490nm Rx Optical Crosstalk	-	-	-47	dB
1310nm Tx to 1555nm Rx Optical Crosstalk	-	-	-47	dB
Back Reflection @ 1310nm	-	-	-6	dB
Back Reflection @ 1555nm	-	-	-32	dB
Back Reflection @ 1490nm	-	-	-20	dB
Total 3.3V Supply Current	-	-	350	mA
Total 12V Supply Current	-	-	225	mA
PSRR (Power Supply Rejection)	-	-	100	mVp-p

Functional Characteristics

The following tables list the performance specifications for the various functional blocks of the integrated optical transceiver module.

Table 3 – Digital Transmitter Specifications

Parameter	Minimum	Typical	Maximum	Unit	Notes
Operating Voltage	3.14	3.30	3.46	V	V _{CC} referenced to GND_Tx
Data Rate	-	1244.16	-	Mbps	
Average Optical Output Power, P _O	0.5	-	5	dBm	
Output Power at Transmit Off	-	-	-40	dBm	
Extinction Ratio	10	-	-	dB	PRBS 2 ²³ -1, NRZ, 50% duty cycle
Transmitter Output Eye	G.984.2 Figure 3				
Optical Rise and Fall Time	-	250	-	ps	20% to 80%
Side Mode Suppression Ration (SMSR)	30	-	-	dB	
Differential Input Voltage, V _{in}	300	-	1800	mVp-p	BEN+/- and TXD+/- DC-coupled
Input Impedance, differential	-	100	-	Ω	BEN+/-, TXD+/-
Common-Mode Input Voltage	GND_Tx + 1.4	-	V _{CC} - (V _{in} /2) - 0.1	V	DC coupled
Tx Burst Enable Time	-	-	12.86	ns	16 bits data @ 1244Mbps
Tx Burst Disable Time	-	-	12.86	ns	16 bits data @ 1244Mbps
Jitter Generation	-	-	0.2	UI	4 kHz to 10 MHz

Refer to Figure 1 which schematically describes the high speed data inputs/outputs of the optical transceiver module.

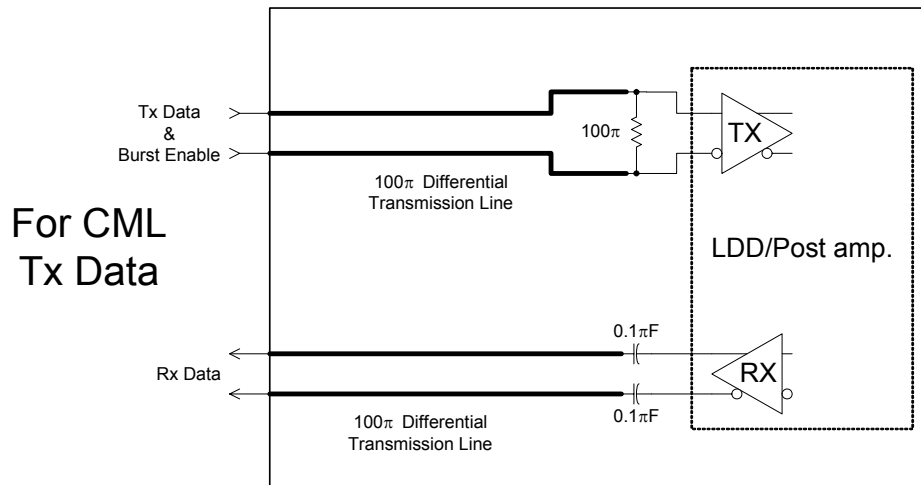

Figure 1 - Schematic representation of the module high speed inputs/outputs

Table 4 – Digital Receiver Specifications

Parameter	Minimum	Typical	Maximum	Unit	Notes
Operating Voltage	3.14	3.30	3.46	V	V _{CC} referenced to GND_RX
Data Rate	-	2488.32	-	Mbps	
Operational Wavelength Range	1480	-	1500	nm	
Received Optical Power	-28	-	-8	dBm	PRBS 2 ²³ -1, 50% duty cycle
Bit Error Rate (BER)		-	10 ⁻¹⁰		
CID	72			bits	
Data Output Rise and Fall Time	-	160	-	ps	20% to 80%
Signal Detect Assertion Level	-		-28	dBm	Transition during increasing light
Signal Detect De-Assertion Level ^a	-38	-	-	dBm	Transition during decreasing light
Signal Detect Hysteresis	0.5	-	-	dB	
Differential Output Voltage	600	-	900	mV	CML output, ac coupled (0.1μF)
Signal Detect Output HIGH Voltage	2.4	-	-	V	LVTTL with internal pull up resistor. Asserts HIGH when input data amplitude is above threshold.
Signal Detect Output LOW Voltage	-	-	0.4	V	LVTTL. De-asserts LOW when input data amplitude is below threshold .
RSSI Range ^b	-28	-	-8	dBm	
RSSI Accuracy	-3	-	+3	dB	

^a Rx outputs are squelched upon Signal Detect de-assert

^b Externally calibrated.

Table 5 – Video Receiver Specifications

Parameter	Minimum	Typical	Maximum	Unit	Notes
12V Operating Voltage Range	11.7	-	13.2	V	
Frequency Range	54	-	870	MHz	
Receiver Wavelength (Bandwidth)	1550	1555	1560	nm	
Responsivity	0.8	-	-	A/W	
Analog Channels	40	-	-		OMI = 4.3%/channel
Digital Channels	63	-	-		OMI = 2.15%/channel
Channel Bandwidth	-	4	-	MHz	
Channel Spacing	-	6	-	MHz	
Video PD Monitor Accuracy	-	-	5	%	
AGC Time Constant	0.5	-	-	s	
Received Average Optical Power	-8	-	2	dBm	
RF Channel Output Power 55 MHz ^a	19	-	23	dBmV	
RF Channel Output Power 450 MHz ^a	19.5	-	23.5	dBmV	
RF Channel Output Power 870 MHz ^{a,b}	15	-	22	dBmV	
S22 Output Return Loss	14	20	-	dB	75Ω
Distortions CSO	-	-65	-55	dBc	For digital channels, CSO max an CTB max will be 7 dB higher
CTB	-	-62	-55		
Carrier to Noise Ratio (CNR)	46	-	-	dB	

a) Valid with CW carriers with Register 32 = 00

b) 6 dB lower because these are digital channel frequencies

Table 6 – Suggested Start-up Sequence

Step	Action
1	Power up the host system, with the RESET pin pulled to ground via a $\leq 4.7k\Omega$ resistor.
2	Drive the RESET pin LOW.
3	Set the BEN control lines to disable the transmitter (BEN lines must be driven with differential logic).
4	Ensure power to the unit is on.
5	Drive the RESET pin HIGH to release the unit to become operational.
6	Wait approximately 250ms until the INTERRUPT pin goes LOW.
7	Read bytes A2.70/71/74/75 to clear the interrupt condition. Verify that byte A2.75 bit 7 was set. Use multi-byte read of bytes 70/71 and bytes 74/75.
8	Wait 50ms. Verify that the INTERRUPT pin has changed to HIGH.
9	The unit is now ready for normal operation.

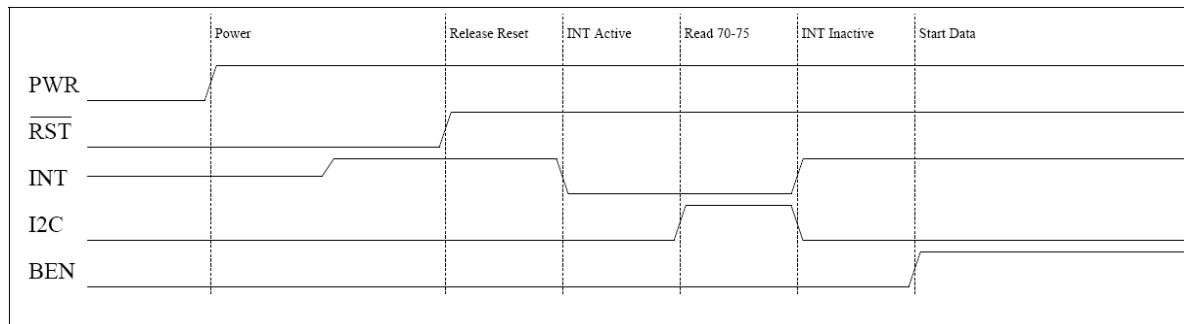

Figure 2 - Recommended transceiver module start-up sequence

Pin Definitions

Refer to Table 7 for a description of the function of each I/O pin.

Table 7 - Module Pin Definitions

Pin Number	Label	Definition
1	GND_A	Common ground
2	GND_Rx	Digital Rx ground
3	Vcc_Rx	Digital Rx Vcc
4	SD	Signal Detect output. LVTTTL with internal 3.3k Ω pull-up. Asserts HIGH when input optical signal level is above threshold.
5	RXD+	RX data output, CML. 50 Ω terminated to Vcc and AC coupled to module output (0.1 μ F)
6	RXD-	RX data bar output, CML. 50 Ω terminated to Vcc and AC coupled to module output (0.1 μ F)
7	BEN+	Burst Enable input, internally DC coupled.
8	BEN-	Burst Enable bar input, internally DC coupled.
9	GND_Tx	Digital Tx ground
10	TXD+	Tx data input, CML. Internally DC coupled. 100 Ω differential termination.
11	GND_Tx	Digital Tx ground
12	TXD-	Tx data bar input, CML. Internally DC coupled. 100 Ω differential termination.
13	Vcc_Tx	Digital Tx Vcc
14	SDA	I ² C Data input/output. LVTTTL
15	SCL	I ² C Clock input. LVTTTL
16	INT	Interrupt output. LVTTTL with internal 100k Ω pull-up. Active LOW.
17	Vdd_+12V	Video Rx 12V Vdd
18	Vcc_3.3V	Microcontroller Vcc
19	Reset	Reset input. LVTTTL. Internal pull up. Active low.
20	GND_A	Common ground
21	RF_GND	RF ground
22	RF_SIGNAL	RF signal
23	RF_GND	RF ground

Package Diagram

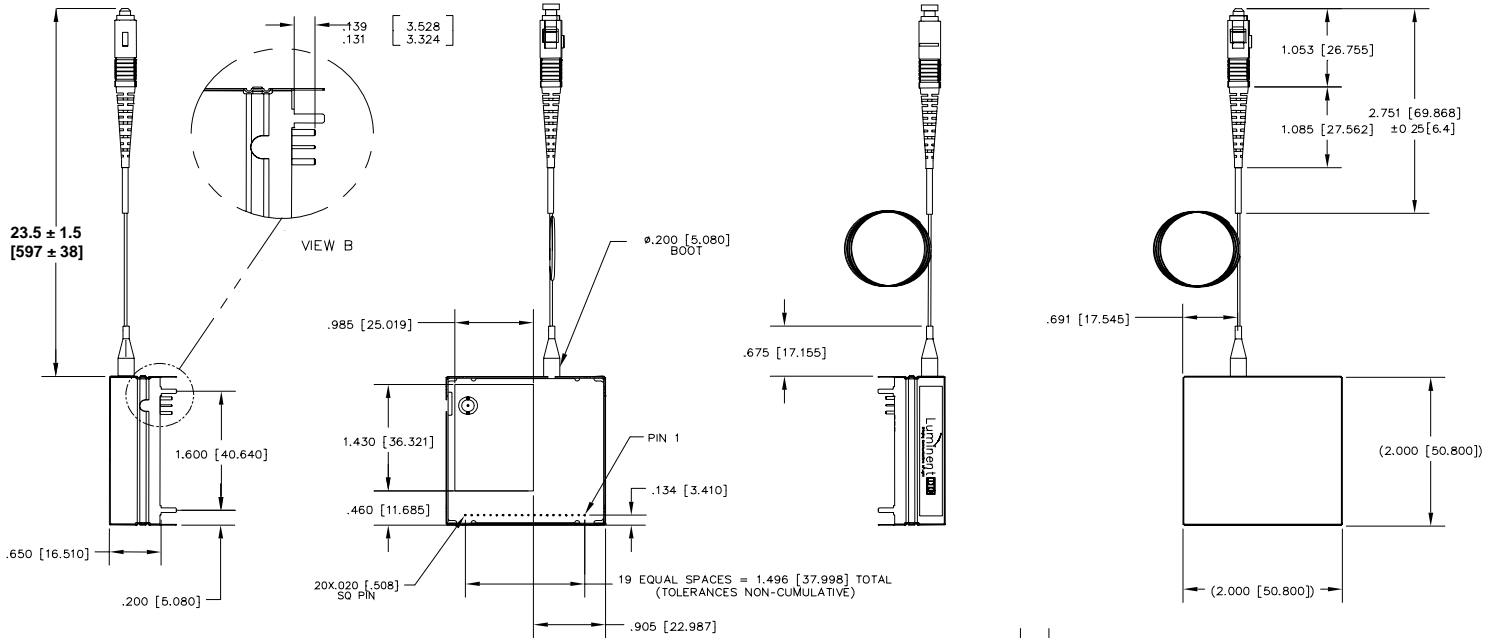

Bottom View
SEE DETAIL B

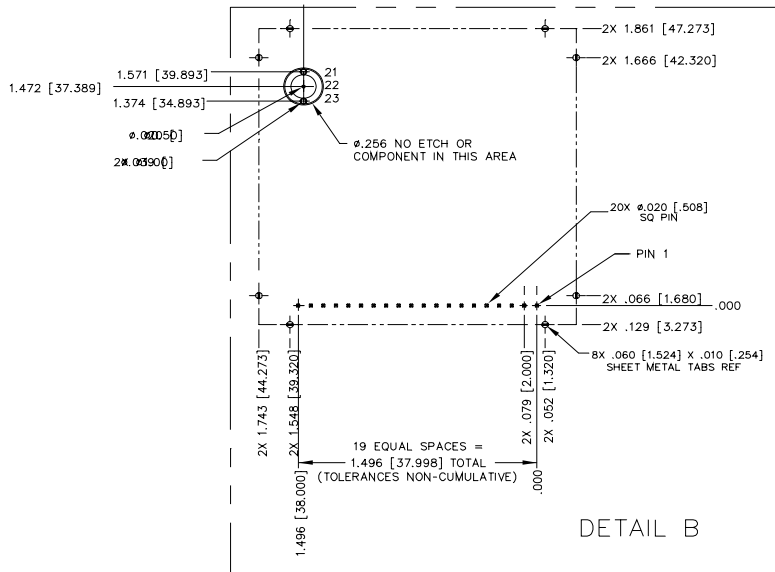
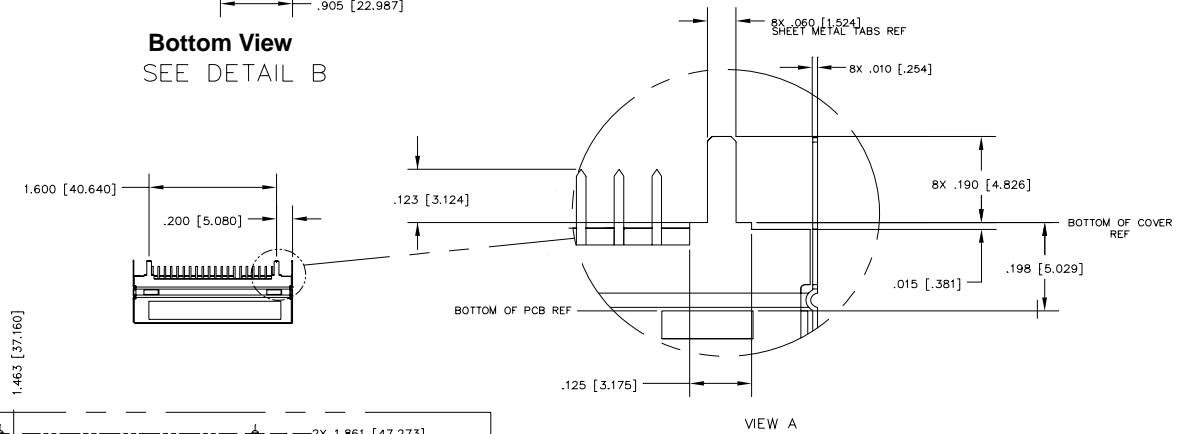

Bottom View

Notes

1. Dimensions in inches [mm]
2. Minimum fiber bend radius = 1.18 [30.00]

Ordering Information

Table 8 - Ordering Information													
ITx		xyz					xy		z		x		
x	Application Type	x	PON Standard	y	Tx Rate	z	Rx Rate	xy	Customer	z	Platform	Revision	Supplemental
R	Integrated Triplexer, Residential Application	B	BPON, Class B, SC/APC pigtail	1	155Mbps	T	2x Tx rate	SD	Standard	1	μC based; SMB RF connector	Numeric value	C Commercial temp. range (0-70C)
C	Integrated Triplexer, Curb Application	C	BPON, Class B, SC receptacle	2	622Mbps	F	4x	xy	Customer specific	2	μC based; 3-pin RF connector		
D	Integrated Triplexer, Digital Only	G	GPON, 25dB budget, SC/APC pigtail	3	1244Mbps	E	8x			3	μC based; SMB; BPON gain		
V	Integrated Triplexer, Video Only	H	GPON, 28dB Budget, SC/APC Pigtail (FP Laser)	4	2488Mbps	S	16x			5	μC based; SMB; HIGH gain		
		D	GPON, 28dB Budget, SC/APC Pigtail (DFB Laser)	5	4800Mbps					6	μC based; 3RF; HIGH gain		
										7	μC based; SMB; Next gen.		
										8	μC based; 3RF; Next gen.		

Table 12 - Device Handling/ESD Protection

The devices are static sensitive and may easily be damaged if care is not taken during handling. The following handling practices are recommended.

1	Devices should be handled on benches with conductive and grounding surfaces.
2	All personnel, test equipment and tools shall be grounded.
3	Do not handle the devices by their leads.
4	Store devices in protective foam or carriers.
5	Avoid the use of non-conductive plastics, rubber, or silk in the area where the devices are handled
6	All modules shall be packaged in materials that are anti-static to protect against adverse electrical environments.
7	Avoid applications of any voltage higher than maximum rated voltages to this part. For proper operation, any VIN or VOUT should be constrained to the range $GND \leq (VIN \text{ or } VOUT) \leq VCC$. Unused inputs must always be tied to an appropriate logic voltage (e.g. either GND or VCC). Unused outputs must be left open.

Warnings

Handling Precautions: This device is susceptible to damage as a result of electrostatic discharge (ESD). A static free environment is highly recommended. Follow guidelines according to proper ESD procedures.

Laser Safety: Radiation emitted by laser devices can be dangerous to human eyes. Avoid eye exposure to direct or indirect radiation.

Legal Notice

IMPORTANT NOTICE!

All information contained in this document is subject to change without notice, at Source Photonics' sole and absolute discretion. Source Photonics warrants performance of its products to current specifications only in accordance with the company's standard one-year warranty; however, specifications designated as "preliminary" are given to describe components only, and Source Photonics expressly disclaims any and all warranties for said products, including express, implied, and statutory warranties, warranties of merchantability, fitness for a particular purpose, and non-infringement of proprietary rights. Please refer to the company's Terms and Conditions of Sale for further warranty information.

Source Photonics assumes no liability for applications assistance, customer product design, software performance, or infringement of patents, services, or intellectual property described herein. No license, either express or implied, is granted under any patent right, copyright, or intellectual property right, and Source Photonics makes no representations or warranties that the product(s) described herein are free from patent, copyright, or intellectual property rights. Products described in this document are NOT intended for use in implantation or other life support applications where malfunction may result in injury or death to persons. Source Photonics customers using or selling products for use in such applications do so at their own risk and agree to fully defend and indemnify Source Photonics for any damages resulting from such use or sale.

© **Copyright Source Photonics, Inc. 2007~2008**

All Rights Reserved.

All information contained in this document is subject to change without notice. The products described in this document are NOT intended for use in implantation or other life support applications where malfunction may result in injury or death to persons.

The information contained in this document does not affect or change Source Photonics product specifications or warranties. Nothing in this document shall operate as an express or implied license or indemnity under the intellectual property rights of Source Photonics or third parties. All information contained in this document was obtained in specific environments, and is presented as an illustration. The results obtained in other operating environments may vary.

THE INFORMATION CONTAINED IN THIS DOCUMENT IS PROVIDED ON AN "AS IS" BASIS. In no event will Source Photonics be liable for damages arising directly from any use of the information contained in this document.

Contact

SOURCE PHOTONICS
20550 NORDHOFF ST.
CHATSWORTH, CA 91311

sales@sourcephotonics.com

Tel: 818-773-9044 Fax: 818-576-9486

Or visit our website: <http://www.sourcephotonics.com>