

## FEATURES

- True Color PWM™ Dimming Delivers Up to 3000:1 Dimming Ratio
- Built-In Gate Driver for PMOS LED Disconnect
- Three Independent Driver Channels with 750mA, 45V Internal Switches
- Operates in Buck, Boost, Buck-Boost Modes
- CTRL Pin Accurately Sets LED Current Sense Threshold Over a Range of 10mV to 100mV
- Adjustable Frequency: 330kHz to 2.1MHz
- Open LED Protection
- Wide Input Voltage Range:
  - Operation from 3V to 30V
  - Transient Protection to 40V
- Surface Mount Components
- 28-Lead (4mm × 5mm) QFN Package

## APPLICATIONS

- RGB Lighting
- Billboards and Large Displays
- Automotive and Avionic Lighting
- Constant-Current Sources

## DESCRIPTION

The LT<sup>®</sup>3496 is a triple output DC/DC converter designed to operate as a constant-current source and is ideal for driving LEDs. The LT3496 works in buck, boost or buck-boost mode. The LT3496 uses a fixed frequency, current mode architecture resulting in stable operation over a wide range of supply and output voltages. A frequency adjust pin allows the user to program switching frequency between 330kHz and 2.1MHz to optimize efficiency and external component size.

The LT3496 supports 3000:1 dimming control on each channel. Each of the three regulators is independently operated by that channel's PWM signal. The PWM feature allows precise adjustment of the color mixing or dimming ratio of the LED source. Each of the three channels has a built-in gate driver to drive an external LED-disconnect P-channel MOSFET, allowing high dimming range. The output current range of each channel of the LT3496 is programmed with an external sense resistor.

The CTRL pin is used to adjust the LED current either for analog dimming or overtemperature protection.

LT, LT, LTC and LTM are registered trademarks of Linear Technology Corporation. All other trademarks are the property of their respective owners. Patent Pending.

## TYPICAL APPLICATION

High Dimming Ratio Triple Output LED Power Supply

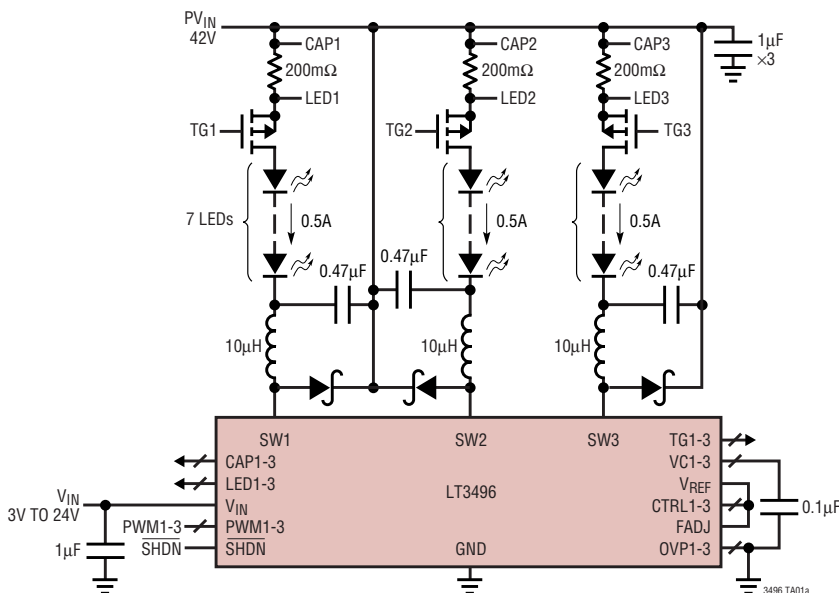

3000:1 PWM Dimming at 120Hz

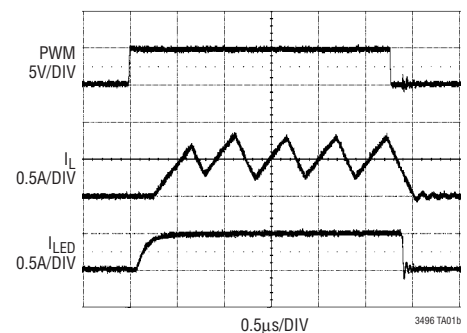

## ABSOLUTE MAXIMUM RATINGS

(Note 1)

$V_{IN}$ (Note 4).....	40V
SW1-SW3, LED1-LED3 .....	45V
TG1-TG3 .....	CAP – 10V to CAP
PWM1-PWM3.....	20V
$V_{REF}$ , CTRL1-CTRL3, FADJ, VC1-VC3, OVP1-OVP3.....	2.5V
SHDN .....	40V
Operating Junction Temperature Range (Note 2).....	-40°C to 125°C
Max Junction Temperature.....	125°C
Storage Temperature Range.....	-65°C to 150°C

## PIN CONFIGURATION

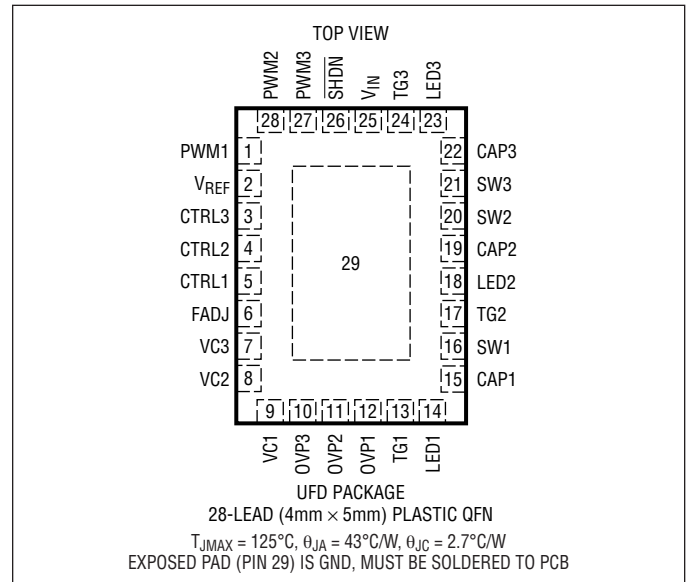

## ORDER INFORMATION

LEAD FREE FINISH	TAPE AND REEL	PART MARKING*	PACKAGE DESCRIPTION	TEMPERATURE RANGE
LTC3496EUFDF#PBF	LTC3496EUFDF#TRPBF	3496	28-Lead (4mm × 5mm) Plastic QFN	0°C to 125°C
LTC3496IUFDF#PBF	LTC3496IUFDF#TRPBF	3496	28-Lead (4mm × 5mm) Plastic QFN	-40°C to 125°C

Consult LTC Marketing for parts specified with wider operating temperature ranges. \*The temperature grade is identified by a label on the shipping container. Consult LTC Marketing for information on non-standard lead based finish parts.

\*For more information on lead free part marking, go to: <http://www.linear.com/leadfree/>  
For more information on tape and reel specifications, go to: <http://www.linear.com/tapeandreeel/>

## ELECTRICAL CHARACTERISTICS

The ● denotes the specifications which apply over the full operating temperature range, otherwise specifications are at  $T_A = 25^{\circ}\text{C}$ .  $V_{IN} = 5\text{V}$ ,  $V_{SHDN} = 5\text{V}$ ,  $CAP1-3 = 5\text{V}$ ,  $PWM1-3 = 5\text{V}$ ,  $FADJ = 0.5\text{V}$ ,  $CTRL1-3 = 1.5\text{V}$ ,  $OVP1-3 = 0\text{V}$ , unless otherwise noted.

PARAMETER	CONDITIONS	MIN	TYP	MAX	UNITS
$V_{IN}$ Operation Voltage	(Note 4)	3		30	V
$V_{IN}$ Undervoltage Lockout			2.1	2.4	V
Full-Scale LED Current Sense Voltage	CAP1-3 = 24V	● 98 97	100	103 104	mV mV
One-Tenth Scale LED Current Sense Voltage	CTRL1-3 = 100mV, CAP1-3 = 24V	● 7.5	10	12.5	mV
CAPn/LEDn Operating Voltage			2.5	45	V
$V_{REF}$ Output Voltage	$I_{REF} = 200\mu\text{A}$	● 1.96	2	2.04	V
$V_{REF}$ Line Regulation	$3\text{V} \leq V_{IN} \leq 40\text{V}$			0.03	%/V
Quiescent Current in Shutdown	SHDN = 0V		0.1	10	$\mu\text{A}$
Quiescent Current Idle	PWM1-PWM3 = 0V		6	7.5	mA
Quiescent Current Active (Not Switching)	VC1-VC3 = 0V		11	14	mA

**ELECTRICAL CHARACTERISTICS** The ● denotes the specifications which apply over the full operating temperature range, otherwise specifications are at  $T_A = 25^\circ\text{C}$ .  $V_{IN} = 5\text{V}$ ,  $V_{\overline{\text{SHDN}}} = 5\text{V}$ ,  $\text{CAP1-3} = 5\text{V}$ ,  $\text{PWM1-3} = 5\text{V}$ ,  $\text{FADJ} = 0.5\text{V}$ ,  $\text{CTRL1-3} = 1.5\text{V}$ ,  $\text{OVP1-3} = 0\text{V}$ , unless otherwise noted.

PARAMETER	CONDITIONS	MIN	TYP	MAX	UNITS
Switching Frequency	FADJ = 1.5V	1900	2100	2300	kHz
	FADJ = 0.5V		1300		kHz
	FADJ = 0.1V		330		kHz
Maximum Duty Cycle	FADJ = 1.5V (2.1MHz)	● 70	78		%
	FADJ = 0.5V (1.3MHz)		87		%
	FADJ = 0.1V (330kHz)		97		%
CTRL1-3 Input Bias Current	Current Out of Pin, CTRL1-3 = 0.1V		20	100	nA
FADJ Input Bias Current	Current Out of Pin, FADJ = 0.1V		20	100	nA
OVP1-3 Input Bias Current	Current Out of Pin, OVP1-3 = 0.1V		10	100	nA
OVP1-3 Threshold		0.95	1	1.05	V
VC1-3 Idle Input Bias Current	PWM1-3 = 0V	-20	0	20	nA
VC1-3 Output Impedance	CAP1-3 = 24V		4.5		MΩ
EAMP $g_m$ ( $\Delta I_V / \Delta V_{\text{CAP-LED}}$ )	CAP1-3 = 24V		200		μS
SW1-3 Current Limit	(Note 3)	750	1000	1250	mA
SW1-3 $V_{\text{CESAT}}$	$I_{\text{SW}} = 500\text{mA}$ (Note 3)		260		mV
SW1-3 Leakage Current	$\overline{\text{SHDN}} = 0\text{V}$ , SW = 5V			2	μA
CAP1-3 Input Bias Current			180	250	μA
CAP1-3, LED1-3 Idle Input Bias Current	PWM1-3 = 0V			1	μA
CAP1-3, LED1-3 Input Bias Current in Shutdown	$\overline{\text{SHDN}} = 0\text{V}$			1	μA
$\overline{\text{SHDN}}$ Input Low Voltage				0.3	V
$\overline{\text{SHDN}}$ Input High Voltage		1.5			V
$\overline{\text{SHDN}}$ Pin Current	$V_{\overline{\text{SHDN}}} = 5\text{V}$		65	100	μA
PWM1-3 Input Low Voltage				0.3	V
PWM1-3 Input High Voltage		1.2			V
PWM1-3 Pin Current			160	210	μA
Gate Off Voltage (CAP1-3–TG1-3)	CAP1-3 = 40V, PWM1-3 = 0V		0.1	0.3	V
Gate On Voltage (CAP1-3–TG1-3)	CAP1-3 = 40V	5.5	6.5	7.5	V
Gate Turn-On Delay	$C_{\text{LOAD}} = 300\text{pF}$ , CAP1-3 = 40V (Note 5)		110		ns
Gate Turn-Off Delay	$C_{\text{LOAD}} = 300\text{pF}$ , CAP1-3 = 40V (Note 5)		110		ns

**Note 1:** Stresses beyond those listed under Absolute Maximum Ratings may cause permanent damage to the device. Exposure to any Absolute Maximum Rating condition for extended periods may affect device reliability and lifetime.

**Note 2:** The LT3496E is guaranteed to meet performance specifications from 0°C to 125°C junction temperature. Specifications over the -40°C to 125°C operating junction temperature range are assured by design, characterization and correlation with statistical process controls. The LT3496I is guaranteed and tested over the full -40°C to 125°C operating junction temperature range.

**Note 3:** Current limit and switch  $V_{\text{CESAT}}$  is guaranteed by design and/or correlation to static test.

**Note 4:** Absolute maximum voltage at the  $V_{IN}$  and  $\overline{\text{SHDN}}$  pins is 40V for nonrepetitive 1 second transients, and 30V for continuous operation.

**Note 5:** Gate turn-on/turn-off delay is measured from 50% level of PWM voltage to 90% level of gate on/off voltage.

## TYPICAL PERFORMANCE CHARACTERISTICS ( $T_A = 25^\circ\text{C}$ unless otherwise noted)

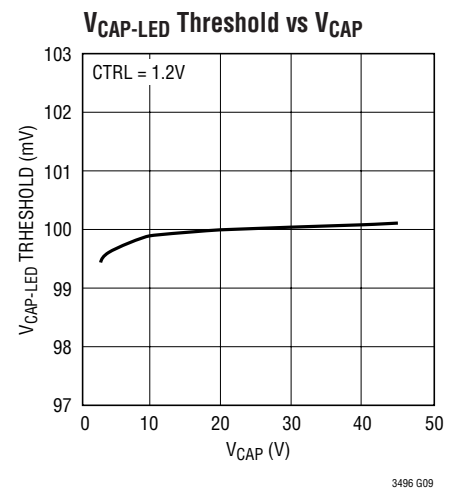
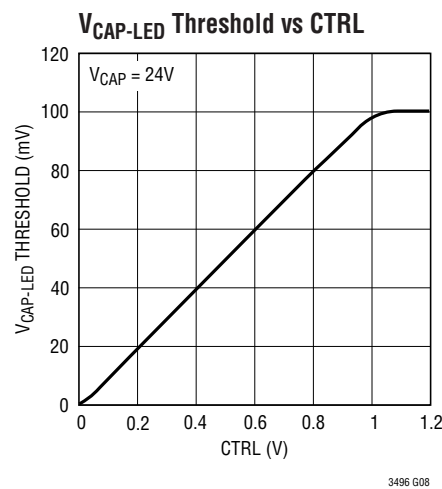
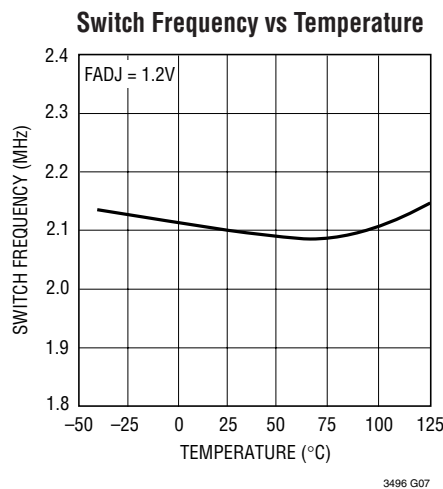
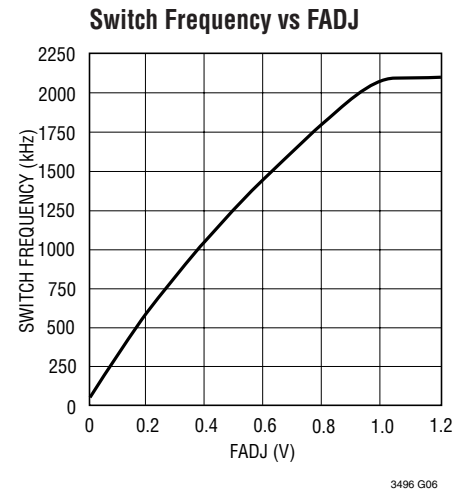
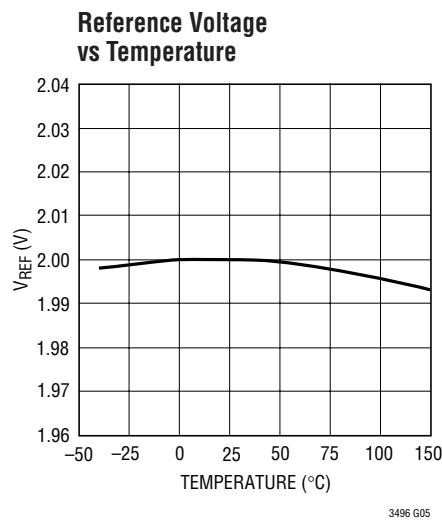
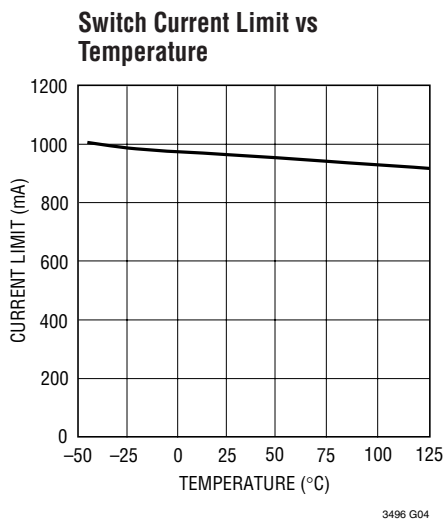
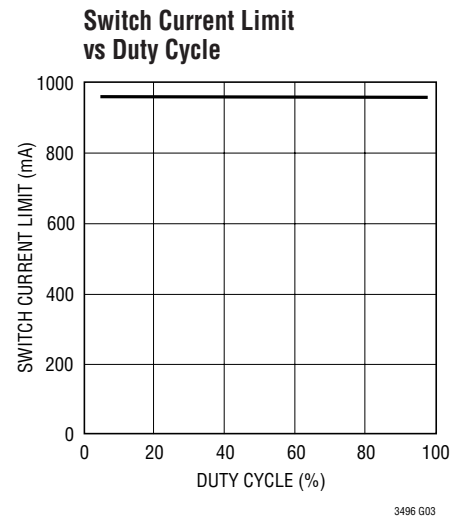
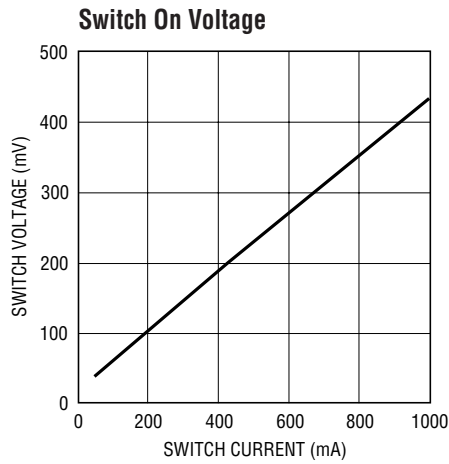
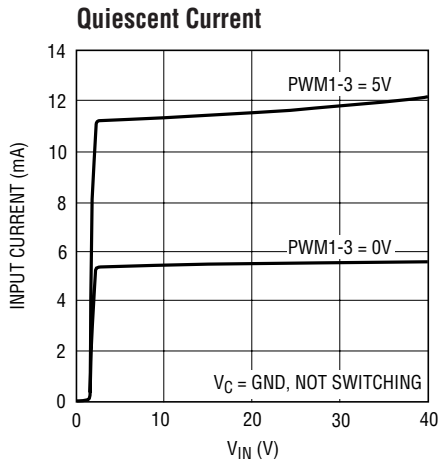

**TYPICAL PERFORMANCE CHARACTERISTICS** ( $T_A = 25^\circ\text{C}$  unless otherwise noted)

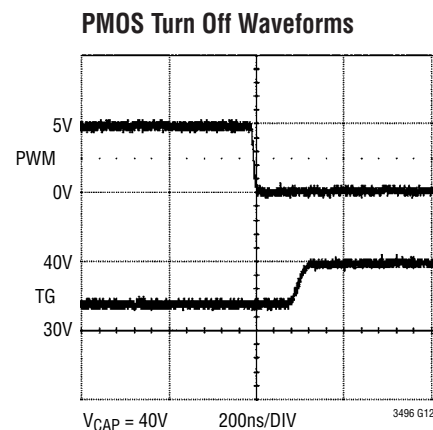
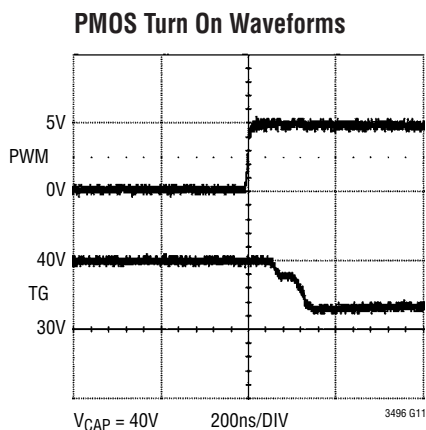
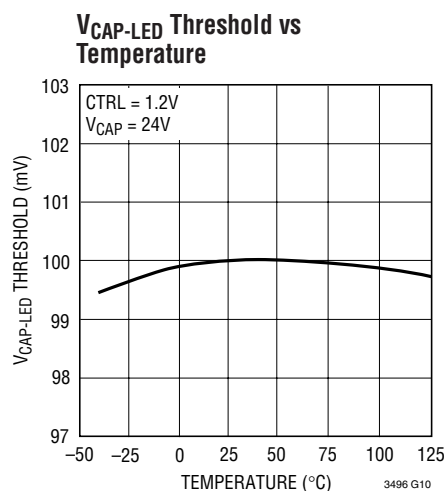

**PIN FUNCTIONS**

**PWM1, PWM2, PWM3 (Pins 1, 28, 27):** Pulse Width Modulated Input. Signal low turns off the respective converter, reduces quiescent supply current and causes the VC pin for that converter to become high impedance. PWM pin must not be left floating; tie to  $V_{REF}$  if not used.

**$V_{REF}$  (Pin 2):** Reference Output Pin. Can supply up to  $200\mu\text{A}$ . The nominal Output Voltage is 2V.

**CTRL1, CTRL2, CTRL3 (Pins 5, 4, 3):** LED Current Adjustment Pins. Sets voltage across external sense resistor between CAP and LED pins of the respective converter. Setting CTRL voltage to be less than 1V will control the current sense voltage to be one-tenth of CTRL voltage. If CTRL voltage is higher than 1V, the default current sense voltage is 100mV. The CTRL pin must not be left floating.

**FADJ (Pin 6):** Switching Frequency Adjustment Pin. Setting FADJ voltage to be less than 1V will adjust switching frequency up to 2.1MHz. If FADJ voltage is higher than 1V, the default switching frequency is 2.1MHz. The FADJ pin must not be left floating.

**VC1, VC2, VC3 (Pins 9, 8, 7):** Error Amplifier Compensation Pins. Connect a series RC from these pins to GND.

**OVP1, OVP2, OVP3 (Pins 12, 11, 10):** Open LED Protection Pins. A voltage higher than 1V on OVP turns off the internal main switch of the respective converter. Tie to ground if not used.

**TG1, TG2, TG3 (Pins 13, 17, 24):** The Gate Driver Output Pin for Disconnect P-Channel MOSFET. One for each converter. When the PWM pin is low, the TG pin pulls up to CAP to turn off the external MOSFET. When the PWM pin is high, the external MOSFET turns on. CAPn-TGn is limited to 7V to protect the MOSFET. Leave open if the external MOSFET is not used.

**LED1, LED2, LED3 (Pins 14, 18, 23):** Noninverting Input of Current Sense Error Amplifier. Connect directly to LED current sense resistor terminal for current sensing of the respective converter

**CAP1, CAP2, CAP3 (Pins 15, 19, 22):** Inverting Input of Current Sense Error Amplifier. Connect directly to other terminal of LED current sense resistor terminal of the respective converter.

**SW1, SW2, SW3 (Pins 16, 20, 21):** Switch Pins. Collector of the internal NPN power switch of the respective converter. Connect to external inductor and anode of external Schottky rectifier of the respective converter. Minimize the metal trace area connected to this pin to minimize electromagnetic interference.

**$V_{IN}$  (Pin 25):** Input Supply Pin. Must be locally bypassed. Powers the internal control circuitry.

## PIN FUNCTIONS

**SHDN (Pin 26):** Shutdown Pin. Used to shut down the switching regulator and the internal bias circuits for all three converters. Tie to 1.5V or greater to enable the device. Tie below 0.3V to turn off the device.

**Exposed Pad (Pin 29):** Signal Ground and Power Ground. Solder paddle directly to ground plane.

## BLOCK DIAGRAM

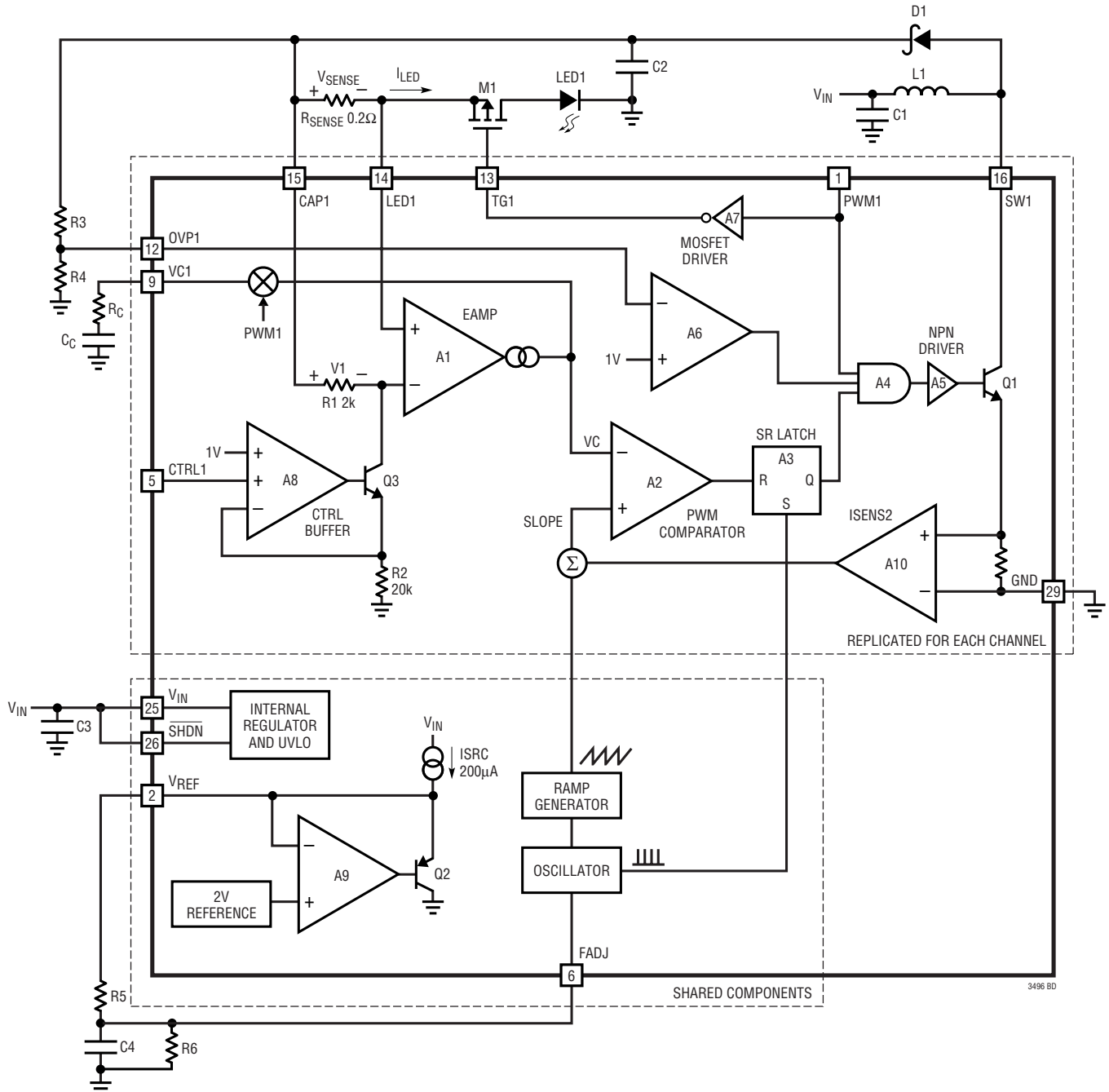

Figure 1. LT3496 Block Diagram Working in Boost Configuration

## APPLICATIONS INFORMATION

### Operation

The LT3496 uses a fixed frequency, current mode control scheme to provide excellent line and load regulation. Operation can be best understood by referring to the Block Diagram in Figure 1. The oscillator, ramp generator, reference, internal regulator and UVLO are shared among the three converters. The control circuitry, power switch etc., are replicated for each of the three converters. Figure 1 shows the shared circuits and only converter 1 circuits.

If the  $\overline{\text{SHDN}}$  pin is tied to ground, the LT3496 is shut down and draws minimal current from  $V_{\text{IN}}$ . If the  $\overline{\text{SHDN}}$  pin exceeds 1.5V, the internal bias circuits turn on. The switching regulators start to operate when their respective PWM signal goes high.

The main control loop can be understood by following the operation of converter 1. The start of each oscillator cycle sets the SR latch, A3, and turns on power switch Q1. The signal at the noninverting input (SLOPE node) of the PWM comparator A2 is proportional to the sum of the switch current and oscillator ramp. When SLOPE exceeds VC (the output of the error amplifier A1), A2 resets the latch and turns off the power switch Q1 through A4 and A5. In this manner, A10 and A2 set the correct peak current level to keep the output in regulation. Amplifier A8 has two noninverting inputs, one from the 1V internal voltage reference and the other one from the CTRL1 pin. Whichever input is lower takes precedence. A8, Q3 and R1 force V1, the voltage across R1, to be one tenth of either 1V or the voltage of CTRL1 pin, whichever is lower.  $V_{\text{SENSE}}$  is the voltage across the sensing resistor,  $R_{\text{SENSE}}$ , which is connected in series with the LEDs.  $V_{\text{SENSE}}$  is compared to V1 by A1. If  $V_{\text{SENSE}}$  is higher than V1, the output of A1 will decrease, thus reducing the amount of current delivered to LEDs. In this manner the current sensing voltage  $V_{\text{SENSE}}$  is regulated to V1.

Converter 2 and converter 3 operate identical to converter 1.

### PWM Dimming Control

LED1 can be dimmed with pulse width modulation using the PWM1 pin and an external P-channel MOSFET, M1. If the PWM1 pin is pulled high, M1 is turned on by internal driver A7 and converter 1 operates nominally. If the PWM1 pin is pulled low, Q1 is turned off. Converter 1 stops operating, M1 is turned off, disconnects LED1 and stops current draw from output capacitor C2. The VC1 pin is also disconnected from the internal circuitry and draws minimal current from the compensation capacitor  $C_C$ . The VC1 pin and the output capacitor store the state of the LED1 current until PWM1 is pulled up again. This leads to a highly linear relationship between pulse width and output light, and allows for a large and accurate dimming range. To optimize the PWM control of all the three channels, the rising edge of all the three PWM signals should be synchronized.

In the applications where high dimming ratio is not required, the external MOSFET M1 can be omitted to reduce cost. In these conditions, TG1 should be left open.

The PWM dimming range can be further increased by using CTRL1 pin to linearly adjust the current sense threshold during the PWM1 high state.

### Open-LED Protection

The LT3496 has open-LED protection for all the three converters. As shown in Figure 1, the OVP1 pin receives the output voltage (the voltage across the output capacitor) feedback signal from an external resistor divider. OVP1 voltage is compared with a 1V internal voltage reference by comparator A6. In the event the LED string is disconnected or fails open, converter 1 output voltage will increase, causing OVP1 voltage to increase. When OVP1 voltage exceeds 1V, the power switch Q1 will turn off, and cause the output voltage to decrease. Eventually, OVP1 will be regulated to 1V and the output voltage will be limited. In the event one of the converters has an open-LED protection, the other converters will continue functioning properly.

## APPLICATIONS INFORMATION

### Switching Frequency and Soft-Start

The LT3496 switching frequency is controlled by FADJ pin voltage. Setting FADJ voltage to be less than 1V will reduce switching frequency.

If FADJ voltage is higher than 1V, the default switching frequency is 2.1MHz. In general, a lower switching frequency should be used where either very high or very low switch duty cycle is required or higher efficiency is desired. Selection of a higher switching frequency will allow use of low value external components and yield a smaller solution size and profile.

Connecting FADJ pin to a lowpass filter (R5 and C4 in Figure 1) from the REF pin provides a soft-start function. During start-up, FADJ voltage increases slowly from 0V to the setting voltage. As a result, the switching frequency increases slowly to the setting frequency. This function limits the inrush current during start-up.

### Undervoltage Lockout

The LT3496 has an undervoltage lockout circuit that shuts down all the three converters when the input voltage drops below 2.4V. This prevents the converter from switching in an erratic mode when powered from a low supply voltage.

### Input Capacitor Selection

For proper operation, it is necessary to place a bypass capacitor to GND close to the  $V_{IN}$  pin of the LT3496. A 1 $\mu$ F or greater capacitor with low ESR should be used. A ceramic capacitor is usually the best choice.

In the buck mode configuration, the capacitor at  $PV_{IN}$  has large pulsed currents due to the current returned through the Schottky diode when the switch is off. For the best reliability, this capacitor should have low ESR and ESL and have an adequate ripple current rating. The RMS input current is:

$$I_{IN(RMS)} = I_{LED} \cdot \sqrt{(1-D) \cdot D}$$

where D is the switch duty cycle. A 1 $\mu$ F ceramic type capacitor placed close to the Schottky diode and the ground plane is usually sufficient for each channel.

### Output Capacitor Selection

The selection of output filter capacitor depends on the load and converter configuration, i.e., step-up or step-down. For LED applications, the equivalent resistance of the LED is typically low, and the output filter capacitor should be large enough to attenuate the current ripple.

To achieve the same LED ripple current, the required filter capacitor value is larger in the boost and buck-boost mode applications than that in the buck mode applications. For the LED buck mode applications, a 0.22 $\mu$ F ceramic capacitor is usually sufficient for each channel. For the LED boost and buck-boost applications, a 1 $\mu$ F ceramic capacitor is usually sufficient for each channel.

Use only ceramic capacitors with X7R or X5R dielectric, as they are good for temperature and DC bias stability of the capacitor value. All ceramic capacitors exhibit loss of capacitance value with increasing DC voltage bias, so it may be necessary to choose a higher value capacitor to get the required capacitance at the operation voltage. Always check that the voltage rating of the capacitor is sufficient. Table 1 shows some recommended capacitor vendors.

**Table 1. Ceramic Capacitor Manufacturers**

VENDOR	TYPE	SERIES
Taiyo Yuden	Ceramic	X5R, X7R
AVX	Ceramic	X5R, X7R
Murata	Ceramic	X5R, X7R
Kemet	Ceramic	X5R, X7R



## APPLICATIONS INFORMATION

### Inductor Selection

Several inductors that work well with the LT3496 are listed in Table 2. However, there are many other manufacturers and devices that can be used. Consult each manufacturer for more detailed information and their entire range of parts. Ferrite core inductors should be used to obtain the best efficiency. Choose an inductor that can handle the necessary peak current without saturating, and ensure that the inductor has a low DCR (copper-wire resistance) to minimize  $I^2R$  power losses. An inductor with a magnetic shield should be used to prevent noise radiation and cross coupling among the three channels.

**Table 2. Surface Mount Inductors**

PART NUMBER	VALUE (μH)	DCR (Ω MAX)	I <sub>RMS</sub> (A)	SIZE W × L × H (mm3)
<b>Sumida</b>				
CMD4D06	2.2	0.116	0.95	3.5 × 4.3 × 0.8
	3.3	0.174	0.77	
CDRH3D16	2.2	0.072	1.20	3.8 × 3.8 × 1.8
	3.3	0.085	1.10	
	4.7	0.105	0.90	
CDRH4D28	10	0.128	1.00	5.0 × 5.0 × 3.0
	15	0.149	0.76	
CDRH5D28	22	0.122	0.9	6.0 × 6.0 × 3.0
	33	0.189	0.75	
<b>CooperET</b>				
SD3112	2.2	0.140	0.97	3.1 × 3.1 × 1.2
	3.3	0.165	0.90	
	4.7	0.246	0.74	
SD14	10	0.2058	1.1	5.0 × 5.0 × 1.4
SD20	15	0.1655	1.25	5.0 × 5.0 × 2.0
	22	0.2053	1.12	
SD25	33	0.2149	1.11	5.0 × 5.0 × 2.5
<b>Taiyo Yuden</b>				
NR3015	2.2	0.06	1.48	3.0 × 3.0 × 1.5
	4.7	0.12	1.02	
NP04SZB	4.7	0.075	1.6	4.0 × 4.0 × 1.8
	10	0.100	1.2	
	15	0.180	0.95	
	22	0.210	0.77	

### Diode Selection

The Schottky diode conducts current during the interval when the switch is turned off. Select a diode  $V_R$  rated for the maximum SW voltage. It is not necessary that the forward current rating of the diode equal the switch current limit. The average current,  $I_F$ , through the diode is a function of the switch duty cycle. Select a diode with forward current rating of:

$$I_F = I_L \cdot (1 - D)$$

where  $I_L$  is the inductor current.

If using the PWM feature for dimming, it is important to consider diode leakage, which increases with the temperature from the output during the PWM low interval. Therefore, choose the Schottky diode with sufficient low leakage current. Table 3 shows several Schottky diodes that work well with the LT3496.

**Table 3. Schottky Diodes**

PART NUMBER	V <sub>R</sub> (V)	I <sub>F</sub> (A)	PACKAGE
<b>ZETEX</b>			
ZLLS350	40	0.38	SOD523
ZLLS400	40	0.52	SOD323

### Programming the LED Current

The LED current of each channel is programmed by connecting an external sense resistor  $R_{SENSE}$  in series with the LED load, and setting the voltage regulation threshold across that sense resistor using CTRL input. If the CTRL voltage,  $V_{CTRL}$ , is less than 1V, the LED current is:

$$I_{LED} = \frac{V_{CTRL}}{10 \cdot R_{SENSE}}$$

If  $V_{CTRL}$  is higher than 1V, the LED current is:

$$I_{LED} = \frac{100mV}{R_{SENSE}}$$

## APPLICATIONS INFORMATION

The CTRL pins should not be left open. The CTRL pin can also be used in conjunction with a PTC thermistor to provide overtemperature protection for the LED load as shown in Figure 2.

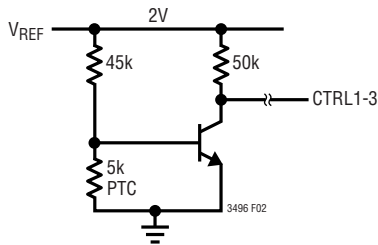

Figure 2

### Thermal Considerations

The LT3496 is rated to a maximum input voltage of 30V for continuous operation, and 40V for nonrepetitive one second transients. Careful attention must be paid to the internal power dissipation of the LT3496 at higher input voltages to ensure that a junction temperature of 125°C is not exceeded. This is especially important when operating at high ambient temperatures. The Exposed Pad on the bottom of the package must be soldered to a ground plane. This ground should then be connected to an internal copper ground plane with thermal vias placed directly under the package to spread out the heat dissipated by the LT3496.

### Board Layout

The high speed operation of the LT3496 demands careful attention to board layout and component placement. The Exposed Pad of the package is the only GND terminal of the IC and is important for thermal management of the IC. Therefore, it is crucial to achieve a good electrical and thermal contact between the Exposed Pad and the ground plane of the board. Also, in boost configuration, the Schottky rectifier and the capacitor between GND and the cathode of the Schottky are in the high frequency switching path where current flow is discontinuous. These elements should be placed so as to minimize the path between SW and the GND of the IC. To reduce electromagnetic interference (EMI), it is important to minimize the area of the SW node. Use the GND plane under SW to minimize interplane coupling to sensitive signals. To obtain good current regulation accuracy and eliminate sources of channel to channel coupling, the CAP and LED inputs of each channel of the LT3496 should be run as separate lines back to the terminals of the sense resistor. Any resistance in series with CAP and LED inputs should be minimized. Finally, the bypass capacitor on the  $V_{IN}$  supply to the LT3496 should be placed as close as possible to the  $V_{IN}$  terminal of the device.

# TYPICAL APPLICATIONS

## Minimum BOM Buck Mode LED Driver

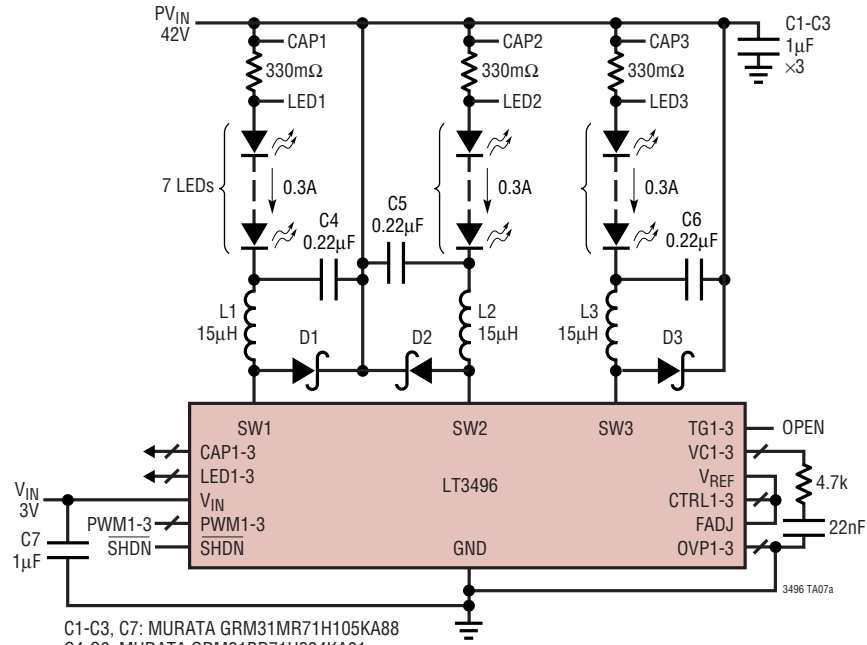

C1-C3, C7: MURATA GRM31MR71H105KA88  
 C4-C6: MURATA GRM21BR71H224KA01  
 D1-D3: DIODES DFLS160  
 L1-L3: TAIYO YUDEN NP04SZB 150M

300:1 PWM Dimming at 120Hz

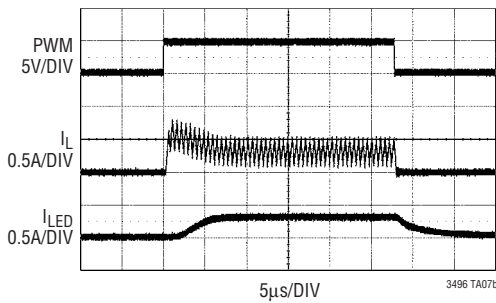

Efficiency

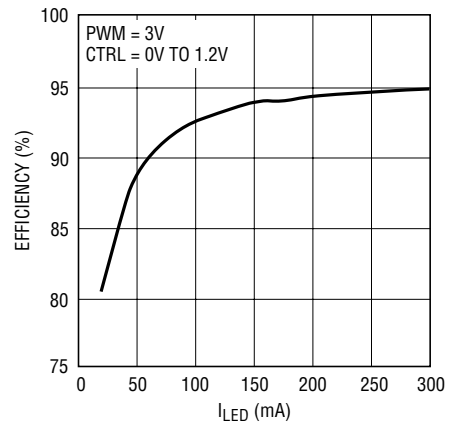

3496 TA07c

TYPICAL APPLICATIONS

Triple Boost 100mA × 10 LED Driver

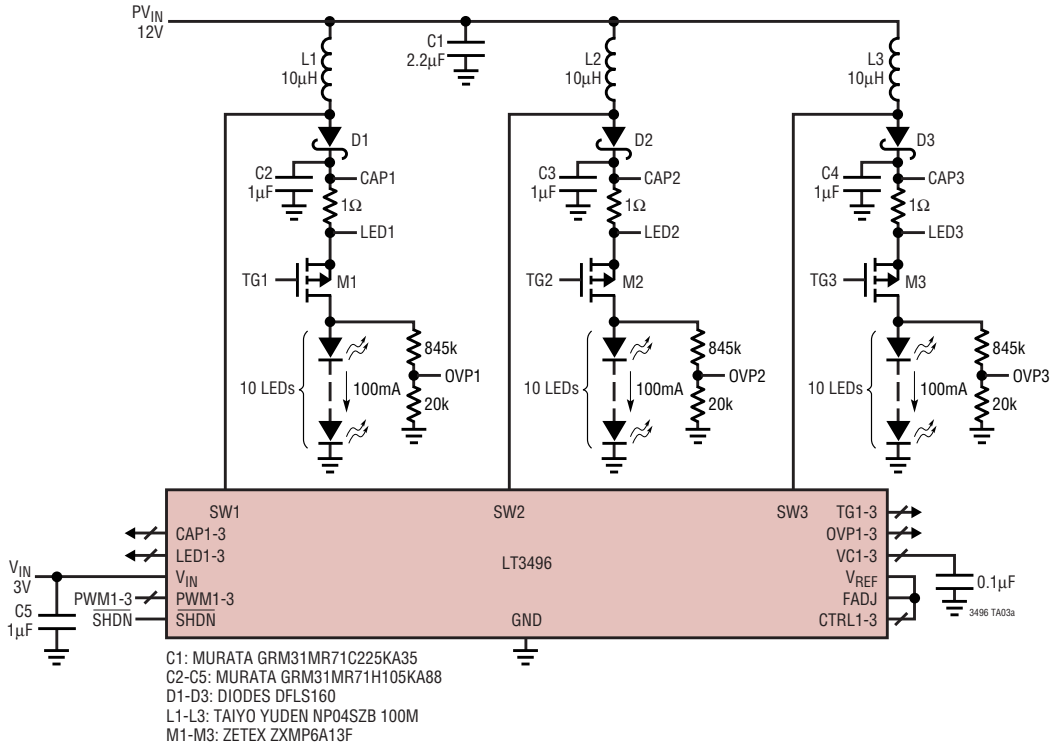

3000:1 PWM Dimming at 120Hz

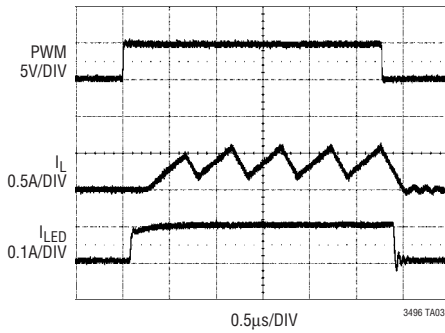

Efficiency vs I\_LED

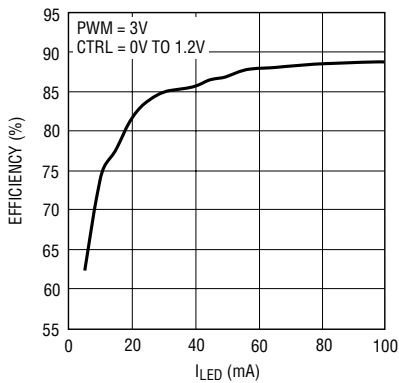

Efficiency vs PWM Duty Cycle

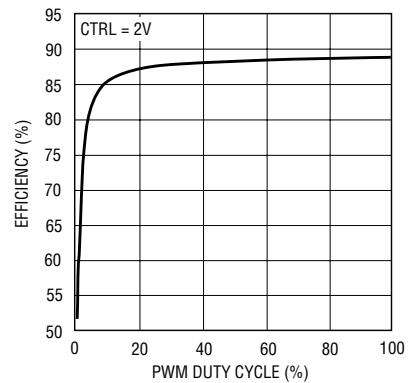

TYPICAL APPLICATIONS

Dual Boost LED Driver

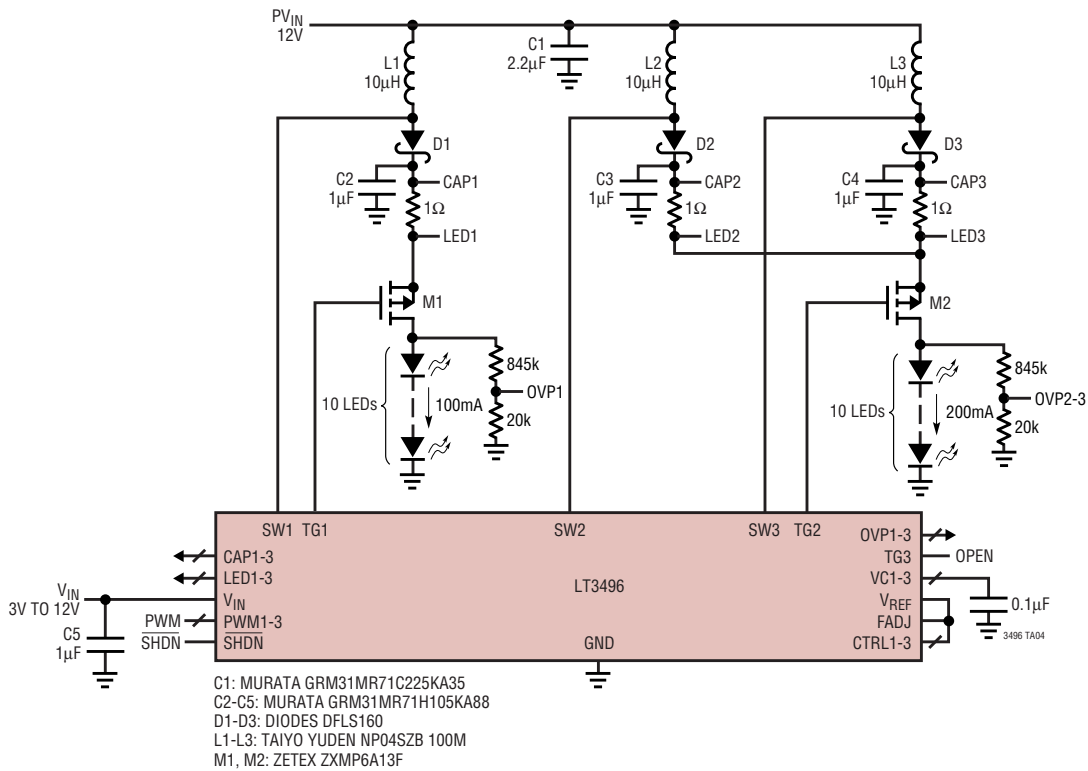

Triple Boost 20mA × 8 LED Driver

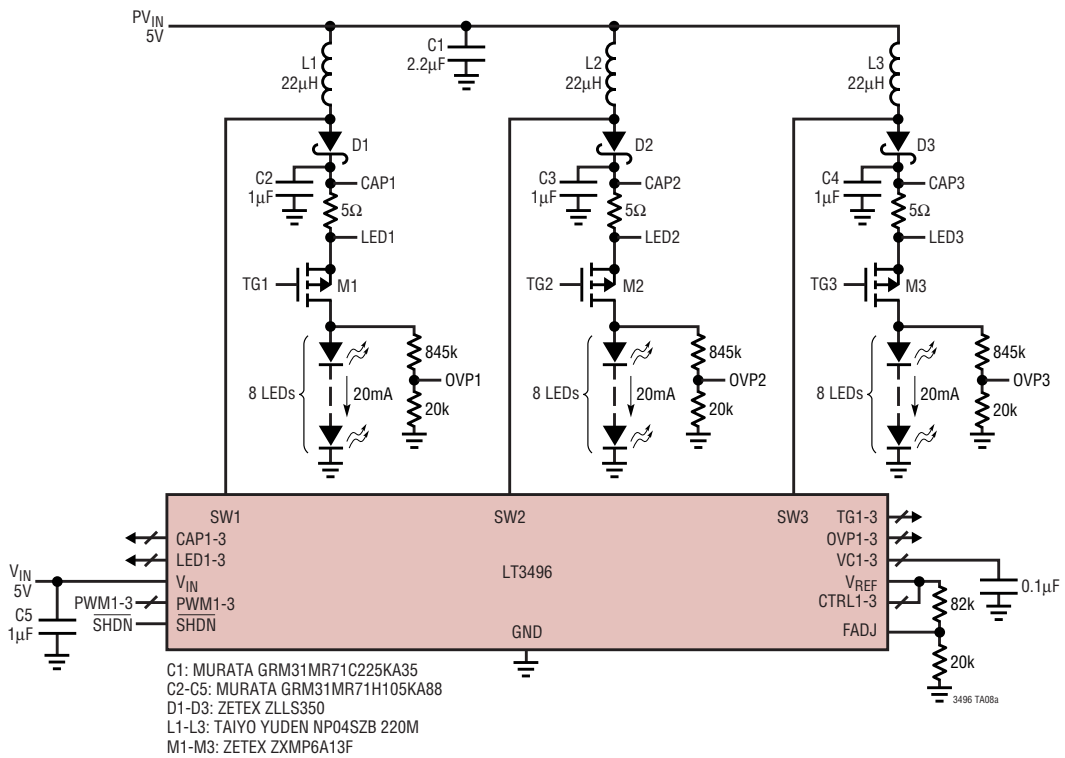

## TYPICAL APPLICATIONS

### Buck-Boost Mode 300mA × 6 LED Driver

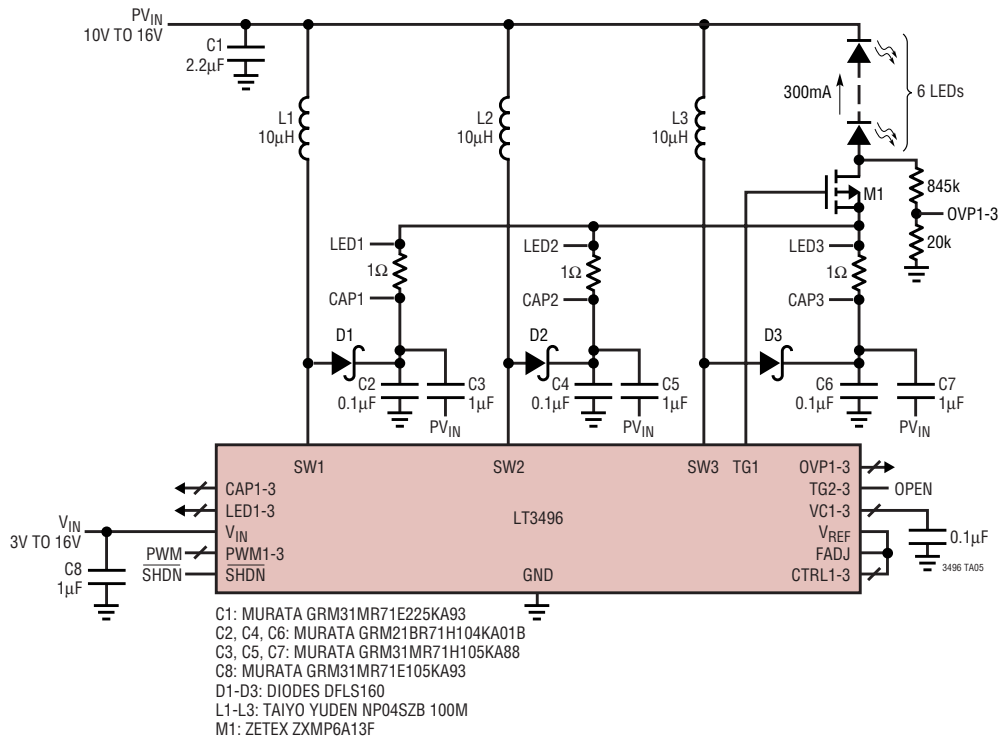

### Triple Buck Mode LED Driver with Open LED Protection

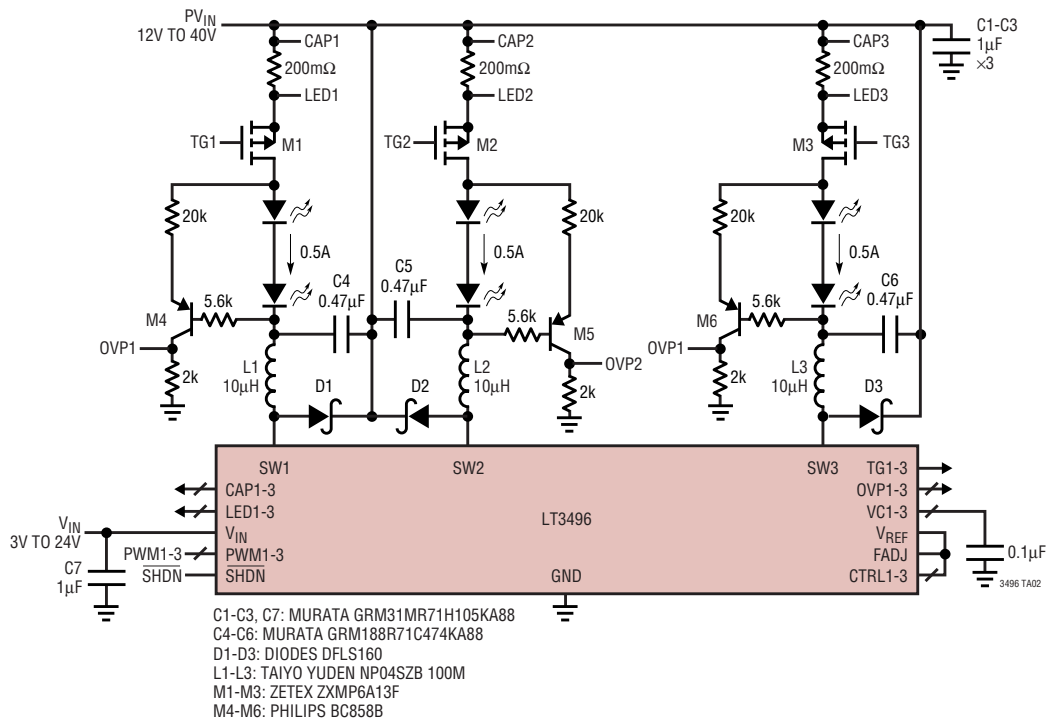



## TYPICAL APPLICATION

### Triple Buck-Boost Mode 100mA × 6 LED Driver

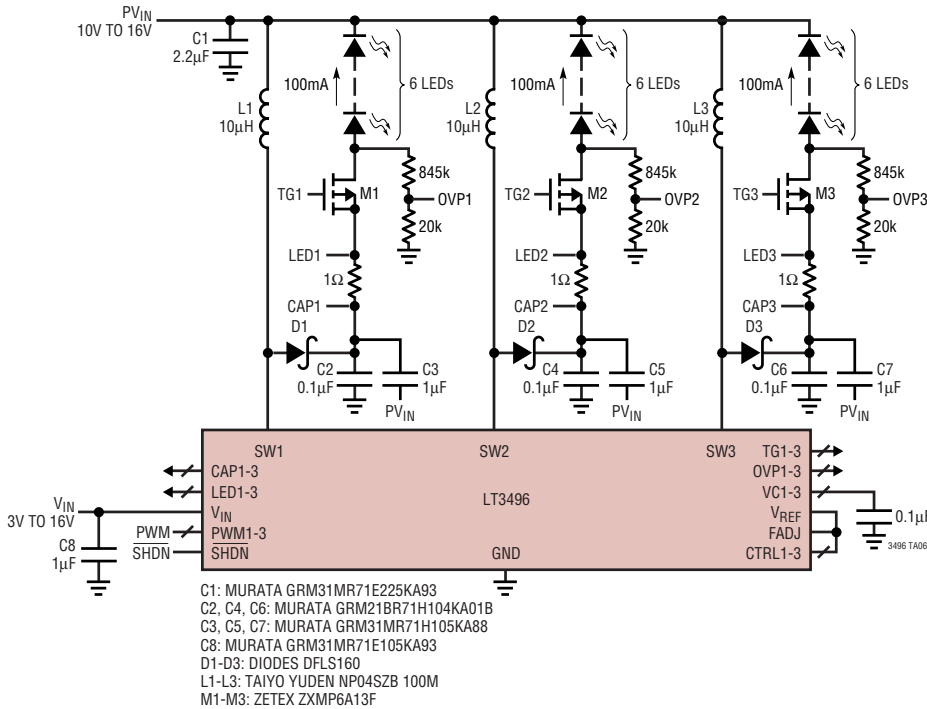

### 3000:1 PWM Dimming at 120Hz

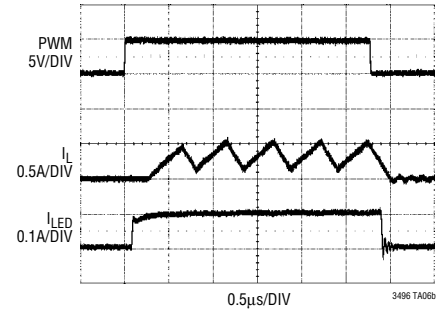

## RELATED PARTS

PART NUMBER	DESCRIPTION	COMMENTS
LT1618	Constant Current, 1.4MHz, 1.5A Boost Converter	$V_{IN}$ : 1.6V to 18V, $V_{OUT(MAX)}$ = 36V, $I_Q$ = 1.8mA, $I_{SD}$ < 1µA, 10-Pin MS Package
LT3453	1MHz, 800mA Synchronous Buck-Boost High Power LED Driver	$V_{IN}$ : 2.7V to 5.5V, $V_{OUT(MAX)}$ = 5.5V, $I_Q$ = 2.5mA, $I_{SD}$ < 6µA, QFN Package
LT3466	Dual Constant Current, 2MHz, High Efficiency White LED Boost Regulator with Integrated Schottky Diode	$V_{IN}$ : 2.7V to 24V, $V_{OUT(MAX)}$ = 40V, $I_Q$ = 5mA, $I_{SD}$ < 16µA, DFN Package
LT3467/LT3467A	1.1A (ISW), 1.3MHz/2.1MHz, High Efficiency Step-Up DC/DC Converters with Integrated Soft-Start	$V_{IN}$ : 2.4V to 16V, $V_{OUT(MAX)}$ = 40V, $I_Q$ = 1.2mA, $I_{SD}$ < 1µA, ThinSOT™ Package
LT3474	Step-Down 1A 2MHz LED Driver	$V_{IN}$ : 4V to 36V, $V_{OUT(MAX)}$ = 15V, $I_Q$ = 2.6mA, $I_{SD}$ < 1µA, TSSOP Package
LT3475	Dual Step-Down 1.5A, 2mV LED Driver	$V_{IN}$ : 4V to 36V, $I_Q$ = 6mA, $I_{SD}$ < 1µA, 20-Lead TSSOPE Package
LT3476	High Current 2MHz Quad 1.5A Output LED Driver	$V_{IN}$ : 2.8V to 16V, $V_{OUT(MAX)}$ = 33.5V, $I_Q$ = 5.5mA, $I_{SD}$ < 1µA, 38-Lead 5mm × 7mm QFN Package
LT3477	3A, 42V, 3MHz Step-Up Regulator with Dual Rail-to-Rail Current Sense	$V_{IN}$ : 2.5V to 2.5V, $V_{OUT(MAX)}$ = 40V, $I_Q$ = 5mA, $I_{SD}$ < 1µA, QFN, 16-Pin TSSOPE Packages
LT3478/LT3478-1	4.5A, 2.25MHz LED Driver with 3000:1 True Color PWM™ Dimming	$V_{IN}$ : 2.8V to 36V, $V_{OUT(MAX)}$ = 40V, $I_Q$ = 6.1mA, $I_{SD}$ < 3µA, 16-Pin TSSOPE Package
LT3479	3A, Full-Featured DC/DC Converter with Soft-Start and Inrush Current Protection	$V_{IN}$ : 2.5V to 24V, $V_{OUT(MAX)}$ = 40V, $I_Q$ = 6.5mA, $I_{SD}$ < 1µA, DFN, TSSOP Packages

ThinSOT and True Color PWM are trademarks of Linear Technology Corporation.