

\*This is tentative specification.

### DESCRIPTION

RT8H042C is composed by NPN transistors, PNP transistors and resistors. This product has the reset function, and controls the backup function of the memory of SRAM and the microcomputer (internal organs RAM)

The reset signal( $\overline{\text{RES}}$ ) is output to the microcomputer when the down of power and the power supply are abnormal. At the same time, RAM is switched from the main power supply to the backup power supply, the signal ( $\overline{\text{CS}}$ ) that becomes a stand-by state is output, and RAM is switched to the backup circuit.

### FEATURES

- Miniaturization of a set.
- Detecting voltage (Power supply watch voltage)  
Standard: 1.23V
- Chip selection signal output ( $\overline{\text{CS}}$ )
- Reset output ( $\overline{\text{RES}}$ )

### APPLICATION

- Backup of memories of 3V faction microcomputer systems such as electronic office equipment, industrial equipment, and home electrical appliances
- Control system of power supply where switch of external source and battery like SRAM board with built-in backup function is needed

### OUTLINE DRAWING

Unit: mm

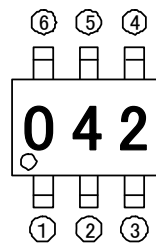
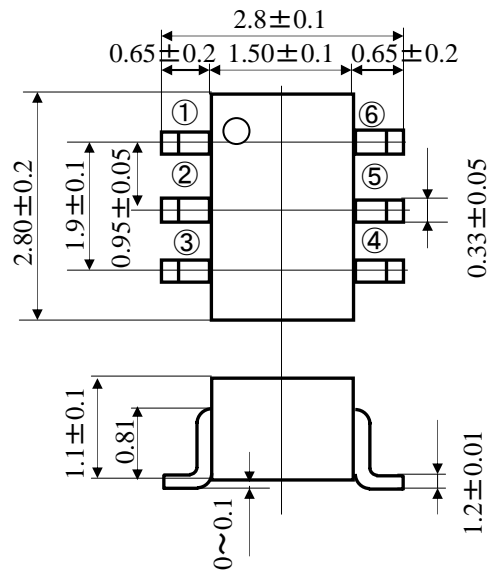

Pin layout

- ①  $\overline{\text{CS}}$
- ② CT
- ③ R
- ④ VIN
- ⑤ GND
- ⑥  $\overline{\text{RES}}$

### BLOCK DIAGRAM

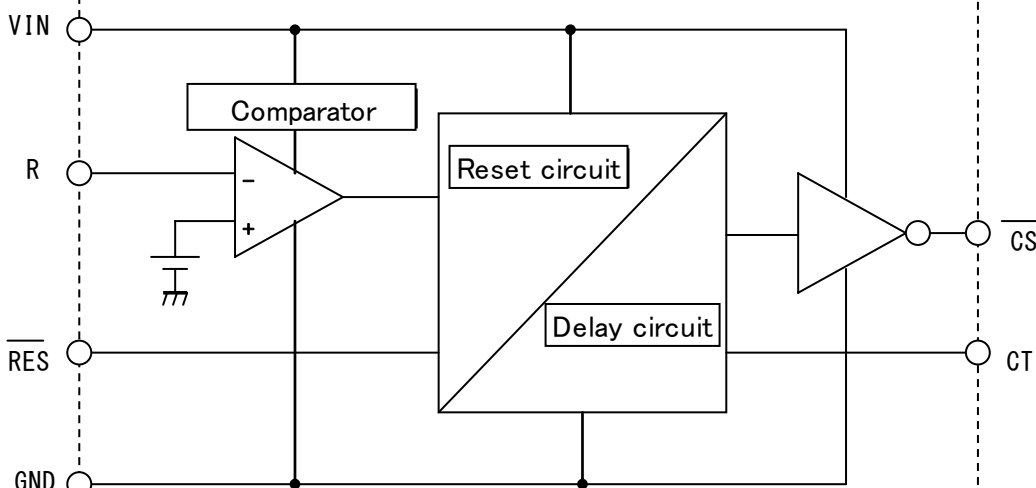

\*This is tentative specification.

### ABSOLUTE MAXIMUM RATINGS (Ta=25°C)

Symbol	Parameter	Test conditions	Ratings	Unit
VIN	Operating supply voltage range		12	V
Pd	Internal power dissipation	Ta ≥ 25°C	200	mW
Kθ	Thermal derating		1.6	mW/°C
Tj	Junction temperature		150	°C
Tstg	Storage temperature	(keep dry)	-40~150	°C
Topr	Operating temperature	(keep dry)	-20~75	°C

### ELECTRICAL CHARACTERISTIC (Ta=25°C, VCC=3V unless otherwise noted.)

Symbol	Parameter	Test conditions	Designed value			Unit
			Min	Typ	Max	
VIN	Operating supply voltage range		2	-	10	V
IIN	Circuit current	RES-VIN: 10kΩ pullup CS: 10kΩ, 3Vpullup, R: 0V	-	700	1050	μA
VRTH	R threshold voltage	R: H⇒L, RES-VIN: 10kΩ pullup CS: 10kΩ, 3Vpullup, CT: OPEN	1.18	1.23	1.28	V
ΔVRTH	Hysteresis	R: H⇒L, RES-VIN: 10kΩ pullup CS: 10kΩ, 3Vpullup	50	104	200	mV
CTH	Output voltage (Terminal CT in level HI)	R: 2V, RES-VIN: 10kΩ pullup CS: 10kΩ, 3Vpullup	0.65	1.32	2	V
CTL	Output voltage (Terminal CT in level Low)	R: 1V, RES-VIN: 10kΩ pullup CS: 10kΩ, 3Vpullup	-	-	0.3	V
RRESL	Output voltage (RES in level Low)	R: 2V, RES-VIN: 10kΩ pullup CS: 10kΩ, 3Vpullup	-	-	VIN	V
RRESH	Output voltage (RES in level HI)	RES: 1mA(SINK) R: 1V, CS: 10kΩ, 3Vpullup	-	-	0.5	V
CSH	Output voltage (CS in level HI)	R: 1V, RES-VIN: 10kΩ pullup CS: 10kΩ, 3Vpullup	-	-	VIN	V
CSL	Output voltage (CS in level Low)	CS: 1mA(SINK) R: 2V, RES-VIN: 10kΩ pullup	-	-	0.5	V
TPD	Delay time	R: L⇒H, RES-VIN: 10kΩ pullup CS: 10kΩ, 3Vpullup, CT: 0.047μF	9.0	18.0	27.0	ms
CSLEAK	CS leak current (VIN in level Low)	RES-VIN: 10kΩ pullup R: LOW(1V), CS: 10kΩ, 3Vpullup	-	-	0.5	μA

Delay time =  $3.83 \times 10^5 \times Ct$

# Preliminary

\*This is tentative specification.

## APPLICATION CIRCUIT EXAMPLES

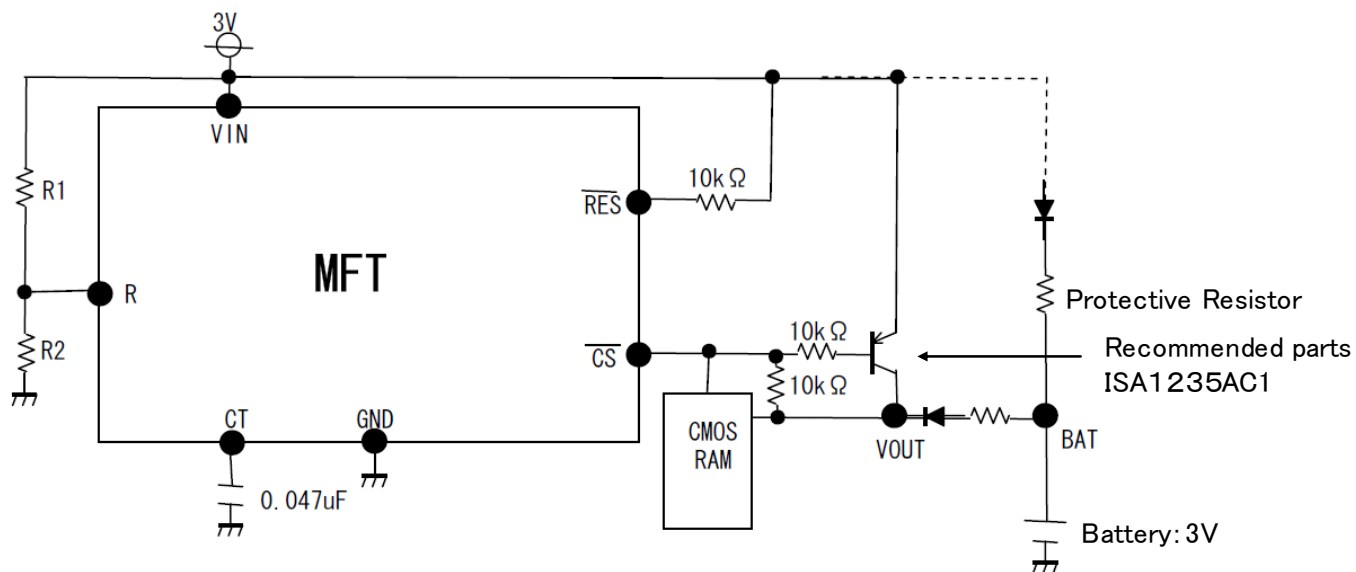



6-41 Tsukuba, Isahaya, Nagasaki, 854-0065 Japan

**Keep safety first in your circuit designs!**

•ISAHAYA Electronics Corporation puts the maximum effort into making semiconductor products better and more reliable, but there is always the possibility that trouble may occur with them. Trouble with semiconductors may lead to personal injury, fire or property damage. Remember to give due consideration to safety when making your circuit designs, with appropriate measures such as (1) placement of substitutive, auxiliary, (2) use of non-flammable material or (3) prevention against any malfunction or mishap.

**Notes regarding these materials**

- These materials are intended as a reference to our customers in the selection of the ISAHAYA products best suited to the customer's application; they don't convey any license under any intellectual property rights, or any other rights, belonging ISAHAYA or third party.
- ISAHAYA Electronics Corporation assumes no responsibility for any damage, or infringement of any third party's rights, originating in the use of any product data, diagrams, charts or circuit application examples contained in these materials.
- All information contained in these materials, including product data, diagrams and charts, represent information on products at the time of publication of these materials, and are subject to change by ISAHAYA Electronics Corporation without notice due to product improvements or other reasons. It is therefore recommended that customers contact ISAHAYA Electronics Corporation or an authorized ISAHAYA products distributor for the latest product information before purchasing product listed herein.
- ISAHAYA Electronics Corporation products are not designed or manufactured for use in a device or system that is used under circumstances in which human life is potentially at stake. Please contact ISAHAYA electronics corporation or an authorized ISAHAYA products distributor when considering the use of a product contained herein for any specific purposes, such as apparatus or systems for transportation, vehicular, medical, aerospace, nuclear, or undersea repeater use.
- The prior written approval of ISAHAYA Electronics Corporation is necessary to reprint or reproduce in whole or in part these materials.
- If these products or technologies are subject to the Japanese export control restrictions, they must be exported under a license from the Japanese government and cannot be imported into a country other than the approved destination. Any diversion or re-export contrary to the export control laws and regulations of Japan and/or the country of destination is prohibited.
- Please contact ISAHAYA Electronics Corporation or authorized ISAHAYA products distributor for further details on these materials or the products contained therein.