

MPO-100S Series

Single Output, 100W Miniature, Open Frame AC/DC Power Supplies

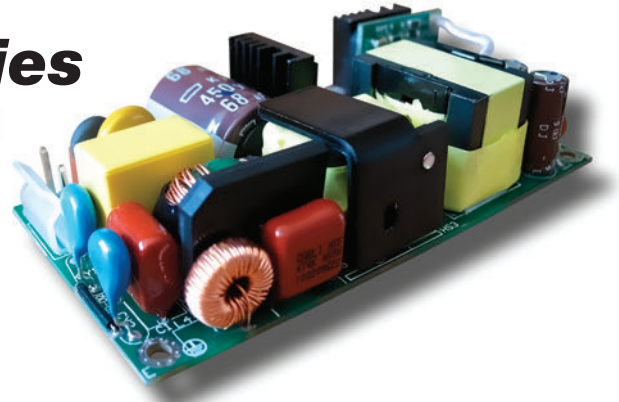

Key Features:

- 100W Output Power
- PFC to EN 61000-3-2,3 "D"
- Universal 90-264 AC Input
- EN 60950 Approved (UL)
- Miniature 2 x 4 In Package
- Meets EN 55022 B
- Meets EN 61000-4
- >200 kHour MTBF



MicroPower Direct

292 Page Street
Suite D
Stoughton, MA 02072
USA

T: (781) 344-8226
F: (781) 344-8481
E: sales@micropowerdirect.com
W: www.micropowerdirect.com



Electrical Specifications

Specifications typical @ +25°C, nominal input voltage & rated output current, unless otherwise noted. Specifications subject to change without notice.

Input

Parameter	Conditions	Min.	Typ.	Max.	Units
Input Voltage Range	Universal	90		264	VAC
		127		373	VDC
Input Frequency		47		63	Hz
Input Filter	Meets EN 55022 Class B; FCC Class B				
Input Current	See Model Selection Guide				
Inrush Current	Cold Start, 115 VAC			40.0	A Pk
	Cold Start, 230 VAC			90.0	
Safety Ground Leakage Current	264 VAC			3.5	mA

Output

Parameter	Conditions	Min.	Typ.	Max.	Units
Output Voltage/Current	See Model Selection Guide				
Output Voltage Tolerance	See Note 1		±1.0		%
Line Regulation	Vin = Min to Max		±0.5		%
Load Regulation	Iout = 10% to 100%		±1.0		%
Ripple & Noise (20 MHz)	See Note 2		±1.0		%
Hold-Up Time	115 VAC		10		mSec
	230 VAC		18		
Temperature Coefficient			±0.05		%/°C
Short Circuit Protection	Continuous (Autorecovery)				
Over Voltage Protection	See Note 3		130		%

General

Parameter	Conditions	Min.	Typ.	Max.	Units
Isolation Voltage	Input to Output	3,000			VAC
Isolation Resistance	500 VDC		1,000		MΩ
Isolation Capacitance			3,300		pF
EMI/RFI	Conducted		EN 55022; EN 61000-3-2, -3		
	Electrostatic Discharge (ESD)		IEC/EN 61000-4-2, -6, -8, -11		
	RF Field Susceptibility		IEC/EN 61000-4-3		
EMC Compliance	Electrical Fast Transients/Bursts On Mains		IEC/EN 61000-4-4		
	Surge		IEC/EN 61000-4-5		
Switching Frequency	Fixed		100		kHz

Environmental

Parameter	Conditions	Min.	Typ.	Max.	Units
Operating Temperature Range	Ambient	0	+25	+40	°C
Storage Temperature Range		-20		+85	°C
Cooling	Free Air Convection (See Derating Curve)				
Humidity	RH, Non-condensing			93	%

Physical

Size	4.00 x 2.00 x 1.10 Inches (101.60 x 50.08 x 27.94 mm)				
Weight	5.99 Oz (0.170 kg)				

Reliability Specifications

Parameter	Conditions	Min.	Typ.	Max.	Units
MTBF	MIL HDBK 217F, 25°C, Gnd Benign	200			kHours
Safety Standards	UL 60950, EN 60950				
Vibration	Sinusoidal 15~2,000 Hz, 4.0 Grms, Period of 60 min each along X, Y & Z Axis				

www.micropowerdirect.com

Model Number	Input		Voltage (VDC)	Output		Max Output Power (W)	Max Output Capacitance (µF)	Efficiency (% Typ)
	Current (A)			Current (A)				
	115 VAC	230 VAC	Rated	% Min.				
MPO-100S-12	1.05	0.60	12.0	8.40	0.00	100	6,000	87
MPO-100S-15	1.05	0.60	15.0	6.70	0.00	100	6,000	87
MPO-100S-20	1.05	0.60	20.0	5.00	0.00	100	4,450	88
MPO-100S-24	1.05	0.60	24.0	4.20	0.00	100	4,450	88
MPO-100S-48	1.05	0.60	48.0	2.10	0.00	100	3,700	89

Notes:

1. Output voltage tolerance is measured at nominal input and 100% load.
2. Output ripple is measured at 20 MHz bandwidth using 0.1 µF and 10 µF capacitors connected in parallel as close to the power supply terminals as possible.
3. These units will operate at no load without damage. For most applications however, MPD recommends that a minimum load always be used. Contact the factory for more information.
4. Each unit includes an input fuse (250V/2A). Since this fuse is not field replaceable, it is recommended that an external fuse of the same size be used on the input of the power supply for protection.

Derating Curve

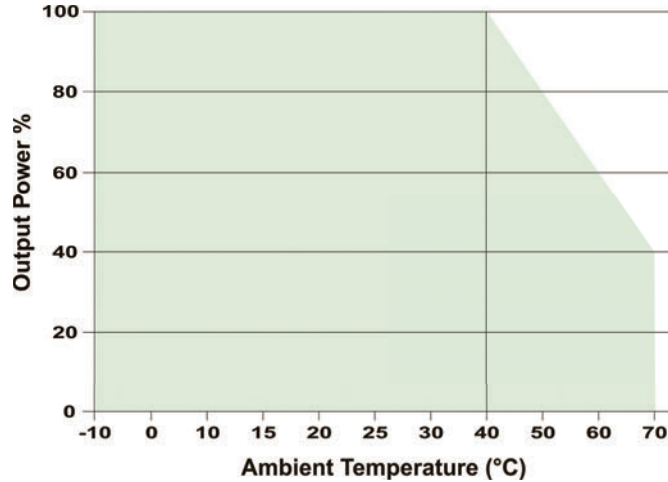

Mechanical Dimensions

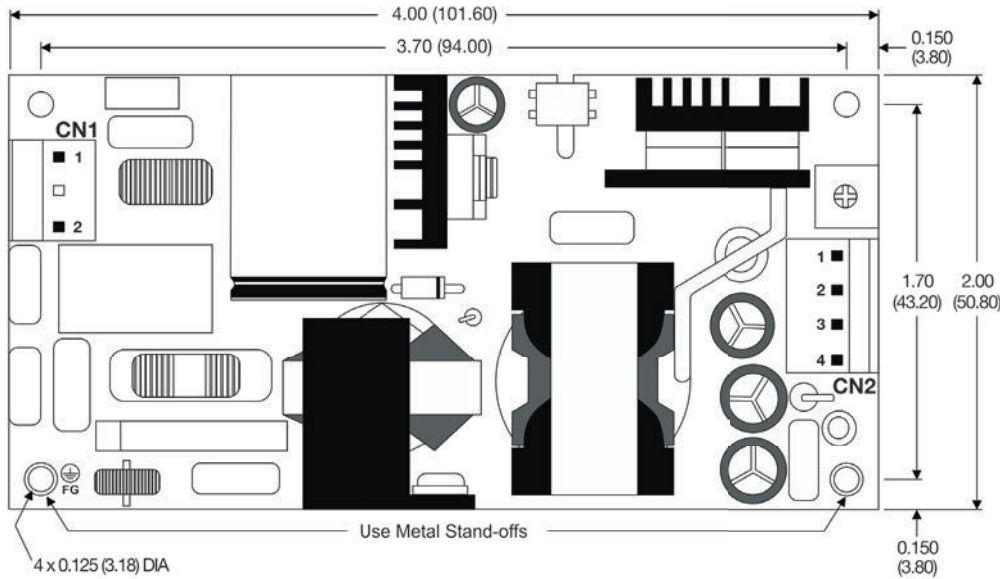

Connections

Input Connector (CN1):

- Molex 5273-03A or equivalent (one pin removed)
- Mating Housing: Molex 5195-03 or equivalent
- Mating Terminal: Molex 5293 or equivalent

Pin	Function
1	AC-Neutral
2	Removed
3	AC-Line

Safety Ground:

The mounting holes marked "Use metal standoffs" should be connected to the system earth ground via metal spacers or a cable. The input side mounting hole marked "FG" provides the safety earth ground for the unit. This connection should be locked to prevent possible loosening. Connecting the output side mounting hole improves EMI.

Output Connector (CN2):

- Molex 5273-04A or equivalent
- Mating Housing: Molex 5195-04 or equivalent
- Mating Terminal: Molex 5293 or equivalent

Pin	Function
1	+V _{OUT}
2	+V _{OUT}
3	-V _{OUT}
4	-V _{OUT}

Notes:

- All dimensions are typical in inches (mm)
- Tolerance x.xx = ±0.02 (±0.50)



MicroPower Direct
We Power Your Success - For Less!