



## UR5516B

## LINEAR INTEGRATED CIRCUIT

### 3A BUS TERMINATION REGULATOR

#### DESCRIPTION

The UTC UR5516B is a low cost linear regulator designed to provide a desired output voltage or termination voltage for various applications by converting voltage supplies ranging from 1V to 6.0V. The desired output voltage could be programmable by two external voltage divider resistors.

The UR5516B is capable of sourcing or sinking up to 2A of current while regulating an output VOUT voltage to within 2% (DDR-I), 3% (DDR-II) or less.

The UR5516B provides low profile 8-pin SOIC package to save system space.

#### FEATURES

- \* Provide bi-direction current
  - Sourcing or sinking current up to 3A
- \* 1.25V/0.9V output for DDR I/II applications
- \* Fast transient response
- \* High output accuracy
  - $\pm 20\text{mv}$  over load,  $V_{\text{OUT}}$  offset and temperature
- \* Adjustable output voltage by external resistors
- \* Current-limit protection
- \* On-chip thermal shutdown
- \* Shutdown for standby or suspend mode

#### ORDERING INFORMATION

Ordering Number		Package	Packing
Normal	Lead Free Plating		
UR5516B-S08-R	UR5516BL-S08-R	SOP-8	Tape Reel
UR5516B-S08-T	UR5516BL-S08-T	SOP-8	Tube

<p>U5516BL-S08-R</p> <p>(1)Packing Type (2)Package Type (3)Lead Plating</p>	<p>(1) R: Tape Reel, T: Tube (2) S08: SOP-8,, (3) L: Lead Free Plating, Blank: Pb/Sn</p>
---	--

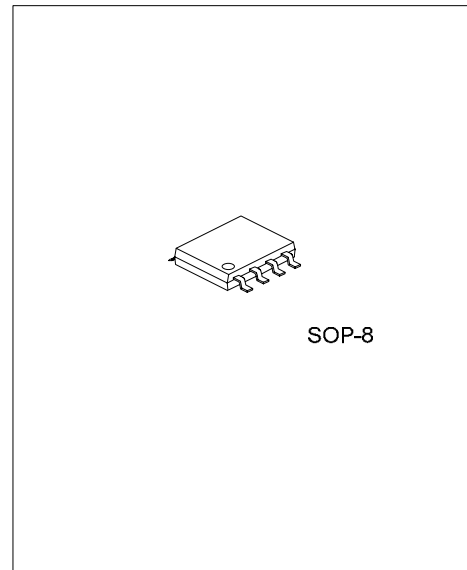

\*Pb-free plating product number: UR5516BL

### ■ PIN CONFIGURATION

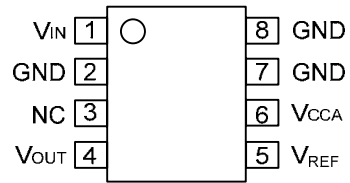

### ■ PIN DESCRIPTION

PIN NO.	PIN NAME	DESCRIPTION
1	V <sub>IN</sub>	Input Power
3	NC	No Connection
4	V <sub>OUT</sub>	Output Voltage
5	V <sub>REF</sub>	Reference Voltage Input and Chip Enable
6	V <sub>CCA</sub>	Voltage supply for internal circuits
2,7,8	GND	Ground

### ■ THERMAL DATA

PARAMETER	SYMBOL	RATINGS	UNIT
Thermal Resistance	$\theta_{JC}$	14	°C/W

■ BLOCK DIAGRAM

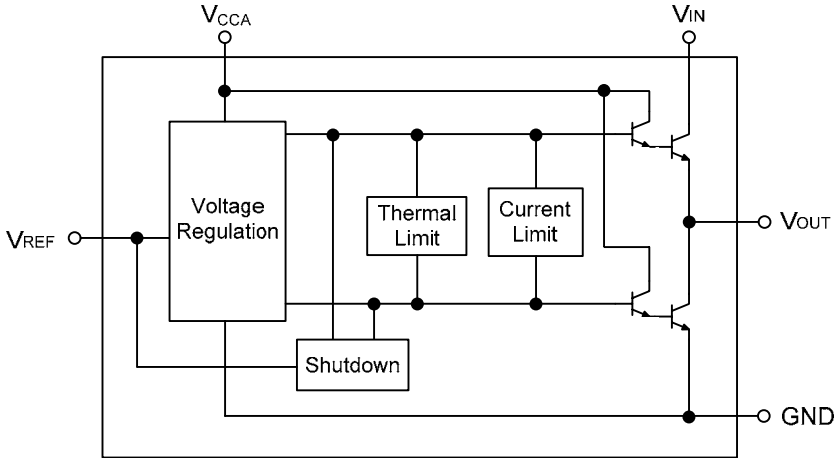

### ■ ABSOLUTE MAXIMUM RATINGS

PARAMETER	SYMBOL	RATINGS	UNIT
V <sub>CCA</sub> Supply Voltage, V <sub>CCA</sub> to GND	V <sub>CCA</sub>	-0.2 ~ 7	V
V <sub>IN</sub> Supply Voltage, V <sub>IN</sub> to GND	V <sub>IN</sub>	-0.2 ~ 3.9	V
Power Dissipation	P <sub>D</sub>	Internally Limited	W
Junction Temperature	T <sub>J</sub>	+150	°C
Storage Temperature	T <sub>STG</sub>	-40 ~ +150	°C

Note Absolute maximum ratings are those values beyond which the device could be permanently damaged. Absolute maximum ratings are stress ratings only and functional device operation is not implied.

### ■ RECOMMENDED OPERATING CONDITIONS

PARAMETER	SYMBOL	RANGES	UNIT
V <sub>CCA</sub> Supply Voltage (Note 1)	V <sub>CCA</sub>	3.1 ~ 6	V
V <sub>IN</sub> Supply Voltage (Note 2)	V <sub>IN</sub>	1.2 ~ 3.5	V
V <sub>REF</sub> Input Voltage	V <sub>REF</sub>	0.85 ~ 1.75	V
V <sub>OUT</sub> Output Voltage (Note 3)	V <sub>OUT</sub>	V <sub>REF</sub> ± 0.02	V
V <sub>OUT</sub> Output Current (Note 4,5)	I <sub>OUT</sub>	-3 ~ +3	A
Junction Temperature	T <sub>J</sub>	0 ~ +125	°C

Note: 1. Please always keep V<sub>CCA</sub> -V<sub>OUT</sub>>1.9V for good regulation.

2. Please supply enough voltage to V<sub>IN</sub> for sourcing desired maximum output current. Please refer to the V<sub>IN</sub> Dropout Voltage vs. Output Current in the Typical Characteristics.
3. The V<sub>OUT</sub> is regulated to the V<sub>REF</sub> with additional voltage offset and load regulation except over-load conditions.
4. The symbol "+" means the V<sub>OUT</sub> sources current to load; the symbol "-" means the V<sub>OUT</sub> sinks current to GND.
5. The max. I<sub>OUT</sub> varies with the T<sub>J</sub> and the voltages of V<sub>IN</sub>-V<sub>OUT</sub> and V<sub>OUT</sub>. Please refer to the Typical Characteristics.

- ELECTRICAL CHARACTERISTICS ( $T_J=25^\circ\text{C}$ ,  $V_{\text{CCA}}=3.3\text{V}$ ,  $V_{\text{IN}}=2.5\text{V}/1.8\text{V}$ ,  $V_{\text{REF}}=0.5V_{\text{IN}}$ , unless otherwise specified)

PARAMETER	SYMBOL	TEST CONDITIONS	MIN	TYP	MAX	UNIT	
Output Voltage	$V_{\text{OUT}}$	$I_{\text{OUT}}=0\text{A}$		$V_{\text{REF}}$		V	
System Accuracy		Over temperature, $V_{\text{OUT}}$ offset, and load regulation	-20		20	mV	
Offset Voltage ( $V_{\text{OUT}}-V_{\text{REF}}$ )	$V_{\text{O(OFF)}}$	$I_{\text{OUT}}=+10\text{mA}$ $I_{\text{OUT}}=-10\text{mA}$	-20		20	mV	
Load Regulation	$\Delta V_{\text{OUT}}$	$I_{\text{OUT}}=+10\text{mA} \sim +3\text{A}$ $I_{\text{OUT}}=-10\text{mA} \sim -3\text{A}$			2 2	%	
Current Limit	$I_{\text{LIMIT}}$	Sourcing Current ( $V_{\text{IN}}=2.5\text{V}$ )	$T_J=25^\circ\text{C}$	+3	+3.6		A
			$T_J=125^\circ\text{C}$		+3.1		
		Sinking Current ( $V_{\text{IN}}=2.5\text{V}$ )	$T_J=25^\circ\text{C}$	-3	-3.6		
			$T_J=125^\circ\text{C}$		-3.1		
		Sourcing Current ( $V_{\text{IN}}=1.8\text{V}$ )	$T_J=25^\circ\text{C}$	+2.9	+3.2		
			$T_J=125^\circ\text{C}$		+2.6		
Sinking Current ( $V_{\text{IN}}=1.8\text{V}$ )	$T_J=25^\circ\text{C}$	-2.9	-3.2				
	$T_J=125^\circ\text{C}$		-2.6				
Thermal Shutdown Temperature	$T_{\text{SHDN}}$	Rising $T_J$		183		$^\circ\text{C}$	
Thermal Shutdown Hysteresis	$T_{\text{HYS}}$			42		$^\circ\text{C}$	
$V_{\text{CCA}}$ Supply Current	$I_{\text{CCA}}$	$I_{\text{OUT}}=0\text{A}$	1	2	3	mA	
		$I_{\text{OUT}}=\pm 3\text{A}$ (Normal Operation)		50	110		
		$V_{\text{REF}}=\text{GND}$ (Shutdown)		2.0			
$V_{\text{REF}}$ Bias Current (The current flows out of $V_{\text{REF}}$ )	$I_{\text{BIAS}}$	$V_{\text{REF}}=1.25\text{V}/0.9\text{V}$ (Normal Operation)		200	500	nA	
		$V_{\text{REF}}=\text{GND}$ (Shutdown)		20	40	$\mu\text{A}$	
Shutdown Threshold Voltage	$V_{\text{SHDN}}$		0.2	0.35	0.65	V	

## ■ APPLICATIONS CIRCUIT

### 1. General Application

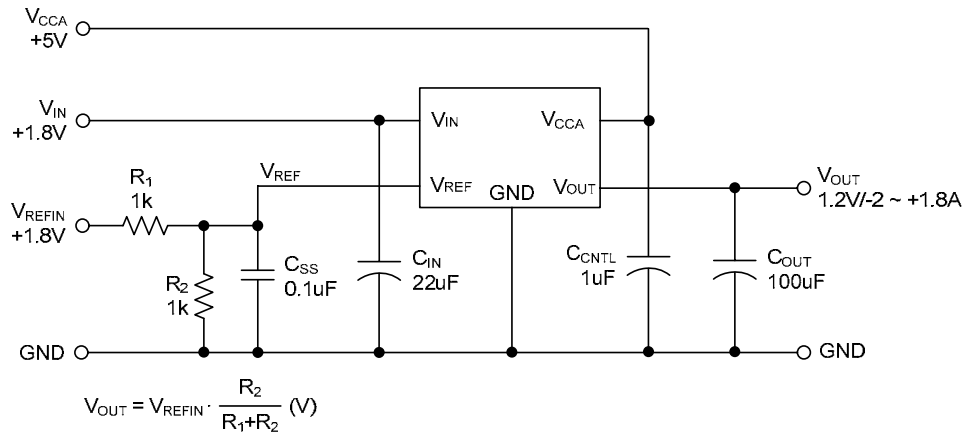

### 2. For V<sub>OUT</sub>=1.25V/0.9V

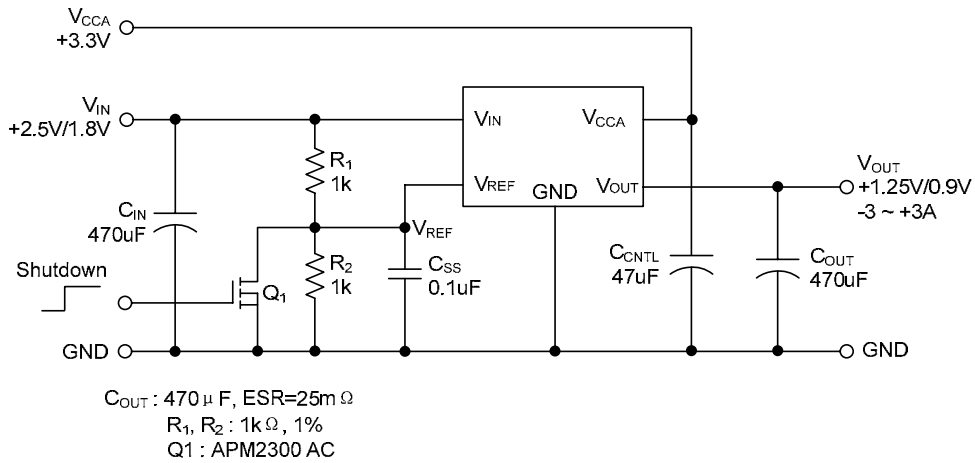

Note : Since R1 and R2 are very small, the voltage offset caused by the bias current of V<sub>REF</sub> can be ignore.

### 3. For V<sub>OUT</sub>=1.4V

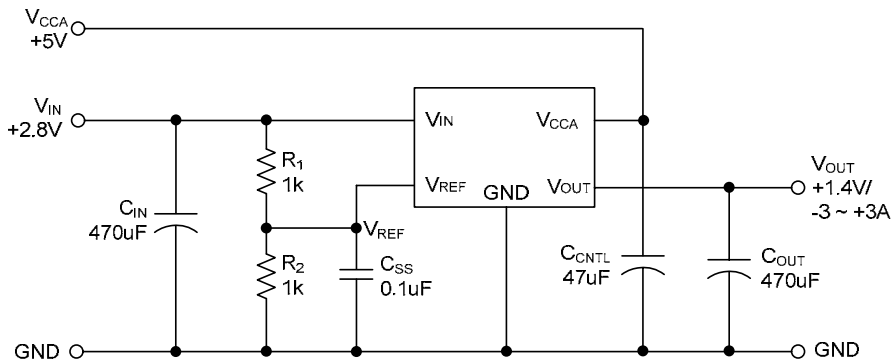

### ■ OPERATING WAVEFORMS

#### 1. Load Transient Response: $I_{OUT} = +10mA \rightarrow +3A \rightarrow +10mA$

- $V_{IN} = 2.5V$ ,  $V_{CNTL} = 3.3V$
- $V_{REF}$  is 1.250V supplied by a regulator
- $C_{OUT} = 470\mu F/10V$ ,  $ESR = 30m\Omega$
- $I_{OUT}$  slew rate =  $\pm 3A/\mu S$

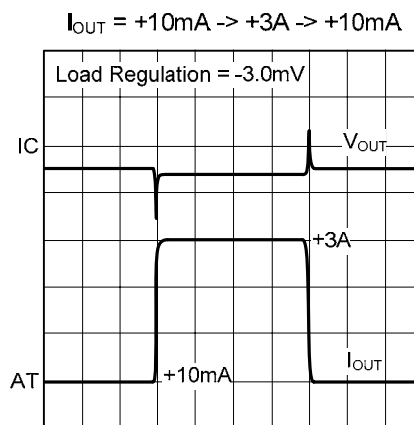

Ch1 :  $V_{OUT}$ , 20mV/Div, DC,  
Offset = 1.250V

Ax1 :  $I_{OUT}$ , 1A/Div  
Time : 20  $\mu$  S/Div

#### 2. Load Transient Response: $I_{OUT} = -10mA \rightarrow -3A \rightarrow -10mA$

- $V_{IN} = 2.5V$ ,  $V_{CCA} = 3.3V$
- $V_{REF}$  is 1.250V supplied by a regulator
- $C_{OUT} = 470\mu F/10V$ ,  $ESR = 30m\Omega$
- $I_{OUT}$  slew rate =  $\pm 3A/\mu S$

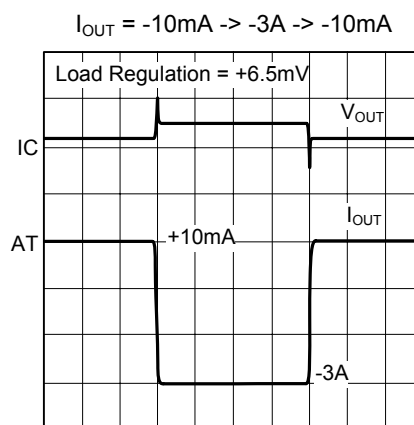

Ch1 :  $V_{OUT}$ , 20mV/Div, DC,  
Offset = 1.250V

Ax1 :  $I_{OUT}$ , 1A/Div  
Time : 20  $\mu$  S/Div

## ■ OPERATING WAVEFORMS(Cont.)

### 3. Load Transient Response: $I_{OUT} = +3A \rightarrow -3A \rightarrow +3A$

- $V_{IN} = 2.5V$ ,  $V_{CCA} = 3.3V$
- $V_{REF}$  is 1.250V supplied by a regulator
- $C_{OUT} = 470\mu F/10V$ ,  $ESR = 30m\Omega$
- $I_{OUT}$  slew rate =  $\pm 3A/\mu S$

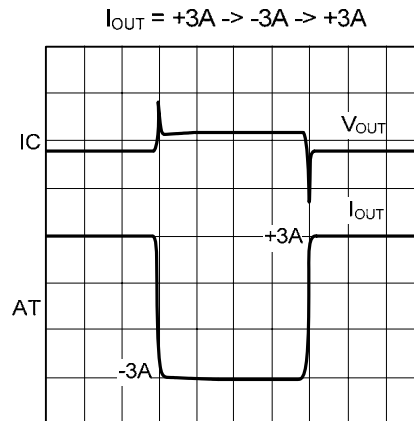

Ch1 :  $V_{OUT}$ , 50mV/Div, DC,  
Offset = 1.250V  
Ax1 :  $I_{OUT}$ , 2A/Div  
Time : 20  $\mu$  S/Div

### 4. Short-Circuit Test

- $V_{IN} = 2.5V$ ,  $V_{CCA} = 3.3V$

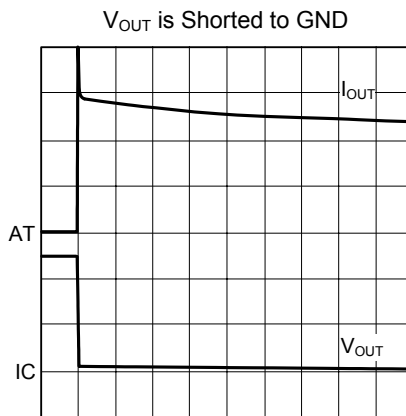

Ch1 :  $V_{OUT}$ , 500mV/Div, DC,  
Offset = 1.250V  
Ax1 :  $I_{OUT}$ , 2A/Div  
Time : 5mS/Div

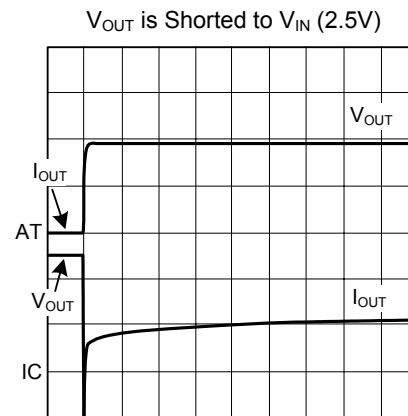

Ch1 :  $V_{OUT}$ , 500mV/Div, DC,  
Offset = 1.250V  
Ax1 :  $I_{OUT}$ , 2A/Div  
Time : 5mS/Div



### ■ TYPICAL CHARACTERISTICS

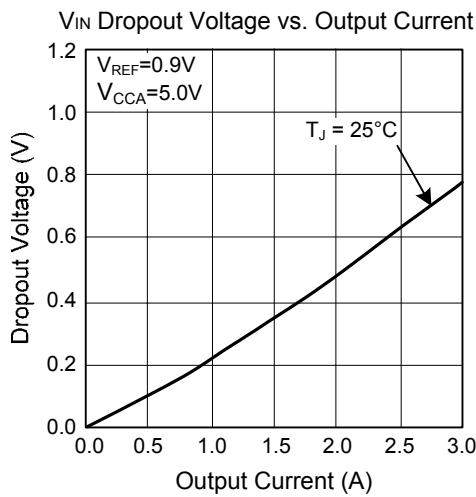
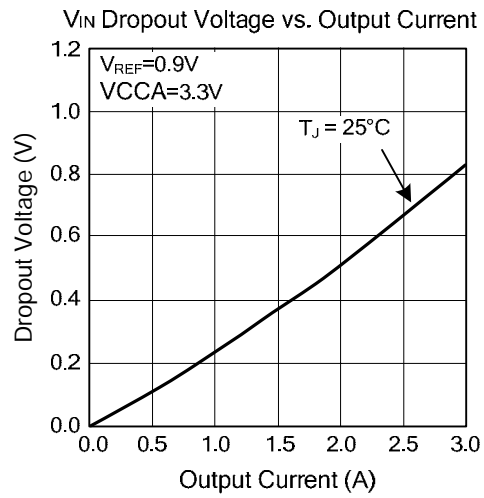
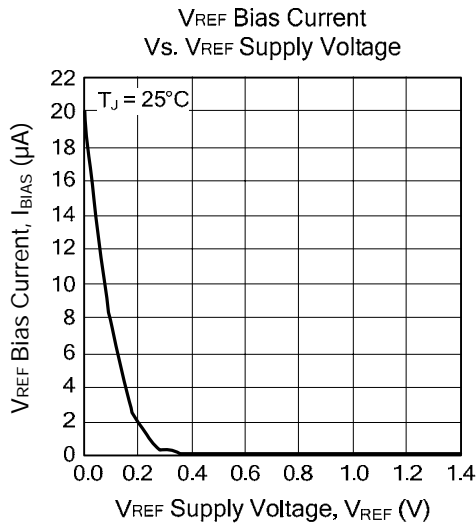

UTC assumes no responsibility for equipment failures that result from using products at values that exceed, even momentarily, rated values (such as maximum ratings, operating condition ranges, or other parameters) listed in products specifications of any and all UTC products described or contained herein. UTC products are not designed for use in life support appliances, devices or systems where malfunction of these products can be reasonably expected to result in personal injury. Reproduction in whole or in part is prohibited without the prior written consent of the copyright owner. The information presented in this document does not form part of any quotation or contract, is believed to be accurate and reliable and may be changed without notice.