

4HEAD PLAYBACK AND RECORD AMPLIFIER FOR VCR

PRELIMINARY DATA

GENERAL

- ONE 5V POWER SUPPLY
- PLAYBACK/RECORD MODE SELECTION THROUGH A LOGIC INPUT
- COMPATIBLE WITH ROTARY TRANSFORMERS WITHOUT ISOLATION RINGS

PLAY-BACK MODE

- LOW NOISE AND WIDE BAND AMPLIFIERS FOR 4 HEADS
- AUTOMATIC OFFSET CANCELLATION BETWEEN THE 2 SELECTED HEADS
- ONE PLAY-BACK OUTPUT WITHOUT AGC
- ONE PLAY-BACK OUTPUT INCLUDING AGC
- OUTPUT FOR TRACKING VIDEO INFORMATION (TRIV) WITH ADJUSTABLE GAIN
- SHORT PLAY/LONG PLAY ENVELOPE COMPARATOR WITH SCHMIDT TRIGGER OUTPUT
- AUTOMATIC SEARCH MODE AVAILABLE
- SHORT CIRCUIT SWITCHES FOR UNUSED HEADS

RECORD MODE

- RECORD AGC AMPLIFIER SAMPLED BY CSYNC
- RECORD MUTE
- SHORT CIRCUIT SWITCHES FOR UNUSED HEADS

DESCRIPTION

The TEA5725 is an advanced four head record and play-back amplifier for VCR.

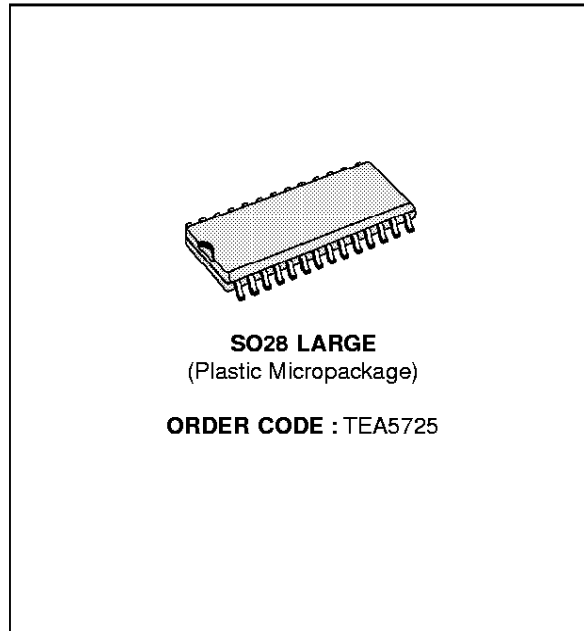

PIN DESCRIPTION

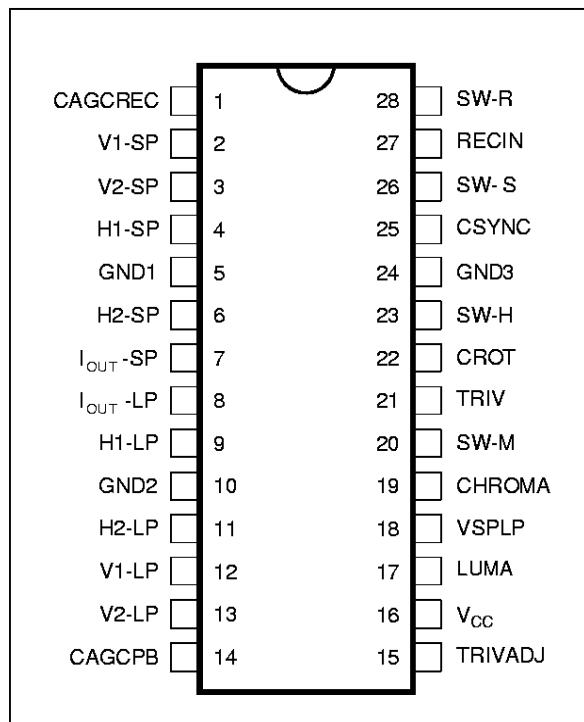

5725-01 EPS

BLOCK DIAGRAM

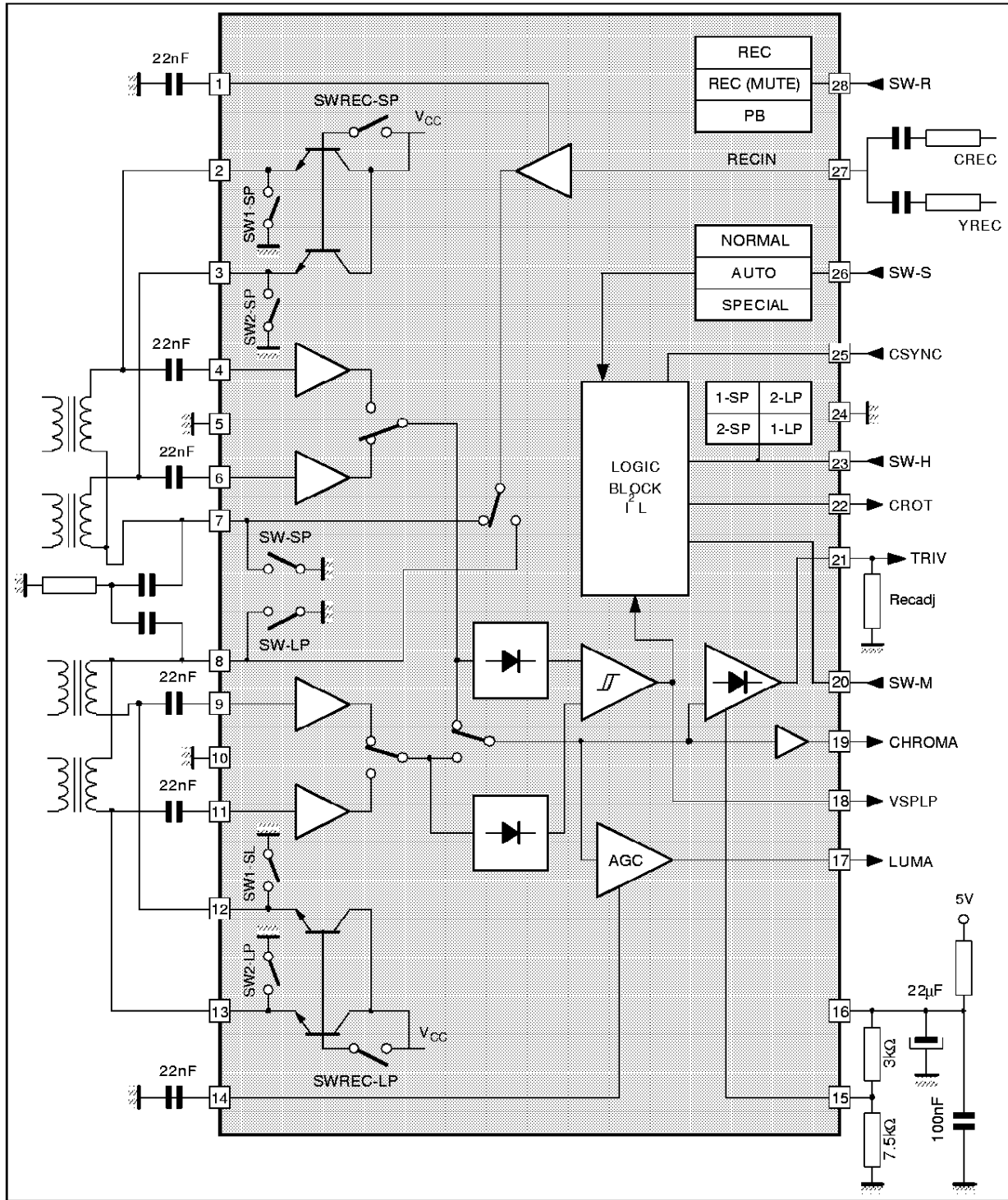

5725-02.EPS

FUNCTIONAL DESCRIPTION

TEA5725 is intended for 4 heads VCR applications. It includes all the electrical functions necessary to achieve play-back and record processing for VHS. High performance technology allows very low noise levels (current and voltage), which are frequency independent in all the frequency range. Optimized play-back output stage gives to the TEA5725 large capability to drive directly a coaxial cable in order to reduce number of external components.

Two play-back outputs are available : one, dedicated to Chroma processing, is a 60dB voltage amplifier output, the other, dedicated to Luma processing, is phase opposite signal with a constant AC output level of 200mV_{PP} at 3.8MHz signal.

A tracking information for video signal (TRIV) is Luma amplitude proportional and allows automatic phase correction. The transfer function has a gain of 2.5dB higher when a LP channel is selected. Adding to this, a gain control bloc allows to modify the gain (± 6 dB) of the TRIV function for all the channels by applying a bias on pin TRIVADJ.

The record amplifier is an AGC sampled by CSYNC input. The output amplitude is adjustable by modifying Recadj resistor value. The unused record amplifier channel inputs are grounded.

During play-back mode, record outputs are grounded through internal transistors.

In play-back normal mode, the unused channel inputs are grounded (ie : LP inputs if mode is SP).

In play-back auto mode, all channels are on and the SP/LP envelope comparator automatically switches between heads (SP or LP one). The color rotation signal is then available to the signal processing IC's.

In play-back special mode, the behaviour is similar to auto mode but channels must be selected through SW-M (and SW-H).

Only one power supply is necessary for play-back and record modes. The mode can be chosen through a logic input. A special care has been taken to avoid current peaks through the rotary transformer.

TEA5725 is fully protected against ESD.

ABSOLUTE MAXIMUM RATINGS

Symbol	Parameter	Value	Unit
V _{CC}	Power Supply Voltage	6	V
T _J	Junction Temperature	+150	°C
T _{oper}	Operating Temperature	0, +70	°C

5725-01.TBL

THERMAL DATA

Symbol	Parameter	Value	Unit
R _{th (j-a)}	Junction-ambient Thermal Resistance	Typ. 70	°C/W

5725-02.TBL

RECOMMENDED OPERATING CONDITIONS (T_{amb} = 25°C)

Symbol	Parameter	Min.	Typ.	Max.	Unit
V _{CC}	Power Supply Voltage	4.75	5	5.25	V
CAGCREC	Capacitance at Pin CAGCREC	4.7			nF
CAGCPB	Capacitance at Pin CAGCPB	4.7			nF

5725-03.TBL

ELECTRICAL OPERATING CHARACTERISTICS (T_{amb} = 25°C unless otherwise specified)

Power Consumption

Symbol	Parameter	Play-Back		Record	
		Typ.	Max.	Typ.	Max.
V _{CC}	Power Supply Voltage	55mA	70mA	70mA	80mA

5725-04.TBL

ELECTRICAL OPERATING CHARACTERISTICS ($T_{amb} = 25^{\circ}\text{C}$ unless otherwise specified)**Play-back Mode** $V_{CC} = 5\text{V}$, no load on Pins CHROMA, LUMA

Symbol	Parameter	Test Conditions	Min.	Typ.	Max.	Unit
I_{CC1}	Supply Current		45	55	70	mA

CHROMA OUTPUT (no AGC)

G_{PB}	Pre-amplification Gain	Sinewave 600 kHz, 400mV _{PP} on output Input on Pin H1-SP or H2-SP, H1-LP or H2-LP	58.5	60	61.5	dB
ΔG_{PB1}	Difference of Output Signal on Pin CHROMA between Channel 1 and Channel 2 in SP Mode	Sinewave 600kHz 0.4mV _{PP} on inputs H1-SP and H2-SP	-1	0	1	dB
ΔG_{PB2}	Difference of Output Signal on Pin CHROMA between Channel 1 and Channel 2 in LP Mode	Sinewave 600kHz 0.4mV _{PP} on inputs H1-LP and H2-LP	-1	0	1	dB
e_N	Equivalent Input Voltage Noise Level	Input grounded via switching transistor on Pins H1-SP, H2-SP, H1-LP, H2-LP, F = 600kHz		0.6		nV/ $\sqrt{\text{Hz}}$
i_N	Equivalent Input Current Noise	Pins H1-SP, H2-SP, H1-LP, H2-LP		1.7		pA/ $\sqrt{\text{Hz}}$
CRT	Crosstalk	Sine wave 3.8MHz 400 μV_{PP} on input, All the other inputs loaded with $R_g = 15\Omega$		-45	-40	dB
R_{PB}	Playback Switch-on Resistance	$\Delta I = 10\text{mA}$		3.0	5.0	Ω
F_{LCPB1} F_{HCPB1}	Bandwidth Cut-off Frequency	-3dB attenuation 50 Ω in parallel on the input, 0dB at 600kHz Low High	8	13.5	0.1	MHz
C_{IN}	Input Capacitance Pins H1-SP, H2-SP, H1-LP, H2-LP	At 5MHz	20	25	30	pF
R_{IN}	Pre-amplifier Input Resistance Pins H1-SP, H2-SP, H1-LP, H2-LP	At 3.8MHz	400	600	900	Ω
Z_{CPB}	Output Impedance Pin CHROMA	DC		24	50	Ω
V_{DCPB1}	DC Level at Play-back Output on Pin CHROMA		1.5	1.9	2.3	V
ΔV_{DCSP} ΔV_{DCLP}	Head Switch Offset Pin CHROMA		-100 -100	0 0	100 100	mV mV
SH_{PB1}	Second Harmonic Play-back Output Pin CHROMA	Sinus wave 3.8MHz 400 μV_{PP} on input		-45	-40	dB

LUMA- OUTPUT (with AGC)

Z_{LPB}	Output Impedance	DC		30	50	Ω
V_{DCPB2}	DC Level		1.1	1.5	2.1	V
F_{LCPB2} F_{HCPB2}	Bandwidth Cut-off Frequency	-3dB attenuation 50 Ω in parallel on the input, AGC locked, 0dB at 3.8MHz Low High	10	12.5	0.1	MHz
V_{LPB}	Output Amplitude	Input signal 200 μV_{PP} at 3.8MHz on Pins H1-SP, H2-SP, H1-LP, H2-LP	158	200	250	mV _{PP}
ΔV_{LPB}	AGC Control Sensitivity	Input signal 200 μV_{PP} at +6dB or -5dB on Pins H1-SP, H2-SP, H1-LP, H2-LP	-2		+1	dB
SH_{PB2}	Second Harmonic Play-back Output	Input Signal 3.8MHz 400 μV_{PP} on Pins H1-SP, H2-SP, H1-LP, H2-LP		-44	-40	dB

CAGCPB

I+	Positive Output Current	Input Signal 3.8MHz 200 μV_{PP} on H1-SP	15	30	45	μA
I-	Negative Output Current	Input Signal 3.8MHz 200 μV_{PP} on H1-SP	-45	-30	-15	μA

5725-05.TBL

ELECTRICAL OPERATING CHARACTERISTICS ($T_{amb} = 25^{\circ}\text{C}$ unless otherwise specified) (continued)**Play-back Mode** $V_{CC} = 5\text{V}$, no load on Pins CHROMA, LUMA

Symbol	Parameter	Test Conditions	Min.	Typ.	Max.	Unit
TRIV						
I_{TRIV}	Downloading Current		200	300	400	μA
V_{TRIV1}	Output Level (1)	With no signal, $V_{TRIVADJ} = 2.5\text{V}$ Mode LP (SW-M = high)	0.3	0.6	1	V
V_{TRIV2}	Output Level (2)	$V_{CHROMA} = 100\text{mV}_{PP}$ at 4MHz $V_{TRIVADJ} = 2.5\text{V}$, Mode LP (SW-M = high)	1.91	2.31	2.71	V
V_{TRIV3}	Output Level (3)	$V_{CHROMA} = 400\text{mV}_{PP}$ at 4MHz $V_{TRIVADJ} = 2.5\text{V}$, Mode LP (SW-M = high)	3.525	3.725	3.925	V
V_{TRIV4}	Output Level (4)	$V_{CHROMA} = 100\text{mV}_{PP}$ at 4MHz $V_{TRIVADJ} = 1\text{V}$, Mode LP (SW-M = high)	1.11	1.61	2.11	V
V_{TRIV5}	Output Level (5)	$V_{CHROMA} = 100\text{mV}_{PP}$ at 4MHz $V_{TRIVADJ} = 4\text{V}$, Mode LP (SW-M = high)	2.875	3.075	3.275	V
V_{TRIV6}	Output Level (6)	$V_{CHROMA} = 400\text{mV}_{PP}$ at 4MHz $V_{TRIVADJ} = 2.5\text{V}$, Mode SP (SW-M = low)	3.215	3.415	3.615	V
f_{TRIV1}	Response Lower Frequency	$V_{CHROMA} = 360\text{mV}_{PP}$ at 4MHz and 1MHz $V_{TRIVADJ} = 2.5\text{V}$, Mode LP (SW-M = high)	-10	-6	-3	dB
f_{TRIV2}	Response Higher Frequency	$V_{CHROMA} = 360\text{mV}_{PP}$ at 8MHz and 4MHz $V_{TRIVADJ} = 2.5\text{V}$, Mode LP (SW-M = high)	-2.5	-1	-0	dB
G_{TRIV}	High Level Input	LP : $V_{CHROMA} = 100\text{mV}_{PP}$, 300mV_{PP} at 4MHz, $V_{TRIVADJ} = 2.5\text{V}$	4	5.5	7	V/V

SP/LP ENVELOPE DETECTOR

R_{OH} R_{OL}	Output Resistance on Pin VSPLP	Output high Output low	7.5 1.5	12.5 2.5	17.5 3.5	$\text{k}\Omega$ $\text{k}\Omega$
R_{CH} R_{CL}	Output Resistance on Pin CROT	Output high Output low	7.5 1.5	12.5 2.5	17.5 3.5	$\text{k}\Omega$ $\text{k}\Omega$

6726-06.TBL

Record Mode $V_{CC} = 5\text{V}$, Ready = $12\text{k}\Omega$, SW-R = 5V, $R_{load} = 50\Omega$, CAGCREC = 22nF, $R_{YCREC} = 1500\Omega$

Symbol	Parameter	Test Conditions	Min.	Typ.	Max.	Unit
I_{CC2}	Current Supply		60	70	80	mA
I_{H0}	DC Current Output on I_{OUT-SP} or I_{OUT-LP}		13	16	19	mA
I_{H1}	Fundamental I_{OUT-SP} or I_{OUT-LP}	$f = 3.8\text{MHz}$, $V_{IN} = 300\text{mV}_{PP}$, CSYNC = 5V	19	20	21	mA_{PP}
I_{H2}	2nd Harmonic I_{OUT-SP} or I_{OUT-LP}	$f = 3.8\text{MHz}$, $V_{IN} = 300\text{mV}_{PP}$, CSYNC = 5V	-50	-40	-35	dB
FLCR	Bandwidth Low Cut-off Frequency Pin I_{OUT-SP} or I_{OUT-LP}	$V_{IN} = 300\text{mV}_{PP}$, AGC locked	50	80	100	kHz
FHCR	Bandwidth High Cut-off Frequency Pin I_{OUT-SP} or I_{OUT-LP}	$V_{IN} = 300\text{mV}_{PP}$, AGC locked	8	10	12	MHz
ΔV_{LREC}	REcord AGC Sensitivity	$V_{IN} = 300\text{mV}_{PP}$, $f = 3.8\text{MHz}$, -3dB, +3dB	-1	0	+1	dB
MR	Muting Ratio	SW-R = 2.5V, $V_{IN} = 300\text{mV}_{PP}$	-60	-45	-40	dB
RSW	Switch Resistance Pin V1-SP, V2-SP, V1-LP, V2-LP	$\Delta I = 10\text{mA}$		3	5	Ω

CAGCREC

I_{AGCR+}	Positive Output Current		15	30	45	μA
I_{AGCR-}	Negative Output Current		-45	-30	-15	μA

6726-07.TBL

ELECTRICAL OPERATING CHARACTERISTICS ($T_{amb} = 25^{\circ}\text{C}$ unless otherwise specified) (continued)

Switching Levels

Symbol	Parameter	Test Conditions	Min.	Typ.	Max.	Unit
V _{SWHH}	Head Selection Pin SW-H	Head number 1 in SP mode, 2 in LP mode (high level)	2.4		V _{CC}	V
V _{SWHL}		Head number 2 in SP mode, 1 in LP mode (low level)	0		1.5	V
I _{SWHH}		Input current (high level)	5	15	50	μA
I _{SWHL}		Output current (low level)	5	20	50	μA
V _{SWMH}	Mode Selection Pin SW-M (Record mode and play-back mode)	LP Mode (high level)	2.4		5	V
V _{SWML}		SP mode (low level)	0		1.5	V
I _{SWMH}		Input current (high level)	5	15	50	μA
I _{SWML}		Output current (low level)	5	20	50	μA
t _{ON} t _{OFF}	Selection Pin SW-H or SW-M Transient Response	Output signal appears on Pin CHROMA Delay time selection ON Delay time selection OFF		100 100	500 500	ns
t ₁	Selection Pin SW-R Transient Response	Delay from play-back to record (signal disappears on Pin CHROMA)		10		μs
t ₂		Delay from record to play-back (signal appears on Pin CHROMA)		2		ms
t ₃		Delay from play-back to record (signal appears on Pin Iout-SP, Iout-LP)		0.2		ms
t ₄		Delay from record to play-back (signal disappears on Pin Iout-SP, Iout-LP)		2		ms
V _{SWR1}	PB/REC Mode Selection	PB mode	0		1.0	V
V _{SWR2}		Record mute mode	1.5		3.5	V
V _{SWR3}		Record mode	4.0		V _{CC}	V
V _{SWRO}	Bias when input open		2	2.5	3	V
R _{SWRO}	Input Resistance when open		30	45	60	kΩ
V _{SWS1}	Special Mode Selection	Special mode	0		1.0	V
V _{SWS2}		Auto mode	1.5		3.5	V
V _{SWS3}		Normal mode	4.0		V _{CC}	V
V _{SWSO}	Bias when input open		2	2.5	3	V
R _{SWRO}	Input Resistance when open		30	45	60	kΩ
V _{SYNL}	Record AGC Sampling Signal Input	AGC measurement on	2.4		V _{CC}	V
V _{SYNH}		AGC measurement off	0		1.5	V
I _{CYNH}				20	50	μA
I _{SYNL}				20	50	μA

5725-08 TBL

INPUT/OUTPUTS EQUIVALENT INTERNAL DIAGRAM

Pins : SW-H, SW-M, SW-S, SW-R, CSYNL

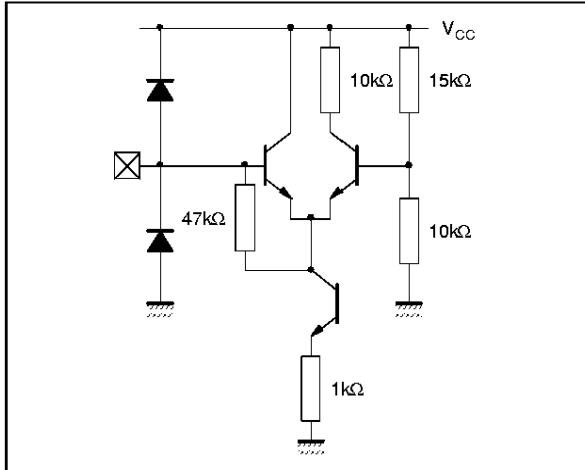

5725-03.EPS

Pins : Chroma, Luma

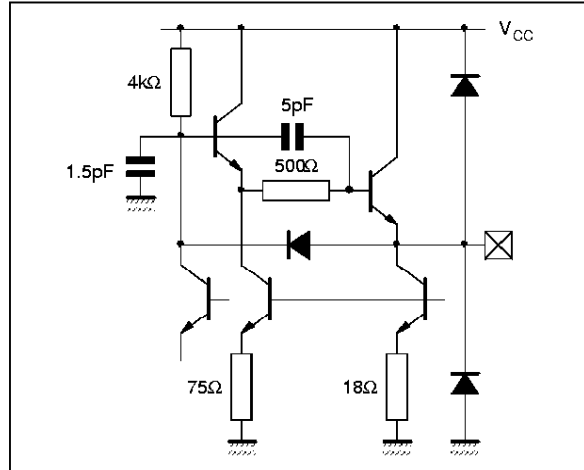

5725-04.EPS

Pins : H1-SP, H2-SP, H1-LP, H2-LP

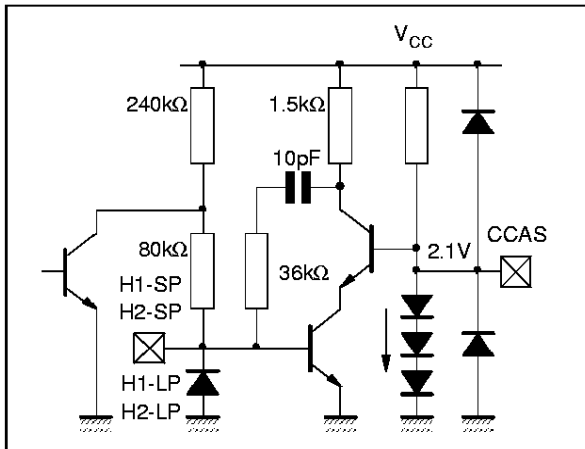

5725-05.EPS

Pin : CAGCPB, CAGCREC

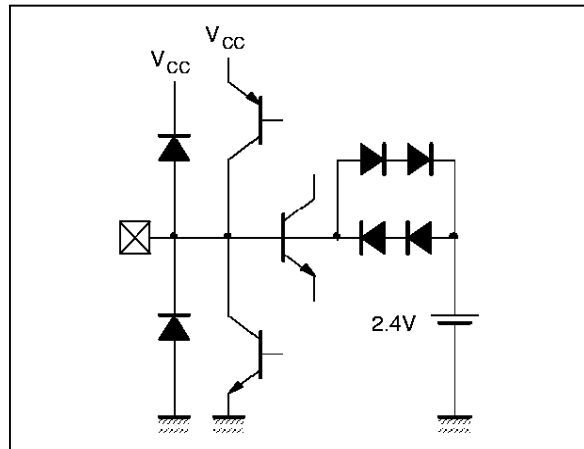

5725-06.EPS

Pin : TRIV

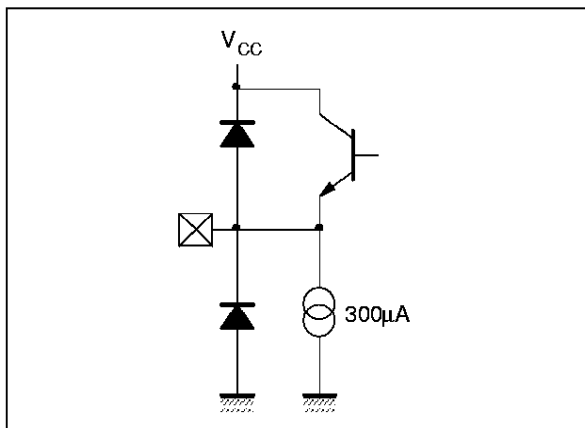

5725-07.EPS

Pin : TRIVADJ

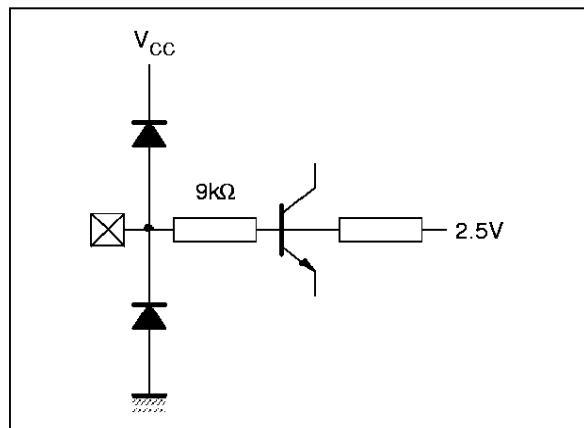

5725-08.EPS

INPUT/OUTPUTS EQUIVALENT INTERNAL DIAGRAM (continued)

Pin : Vcc

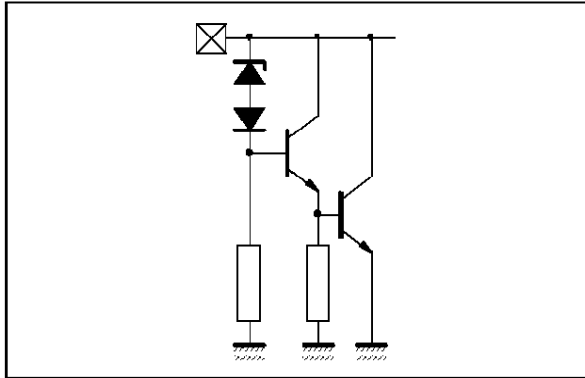

5725-09.EPS

Pin : IOUT-SP, IOUT-LP

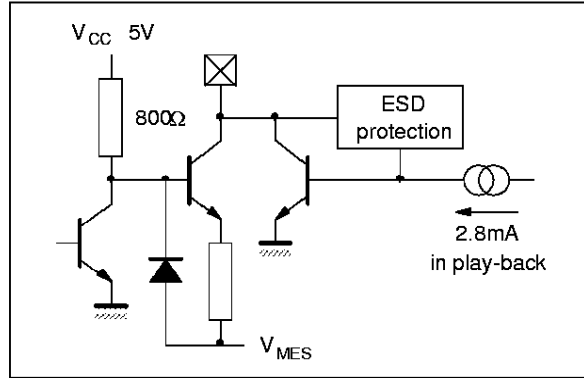

5725-10.EPS

Pin : VSPLP, CROT

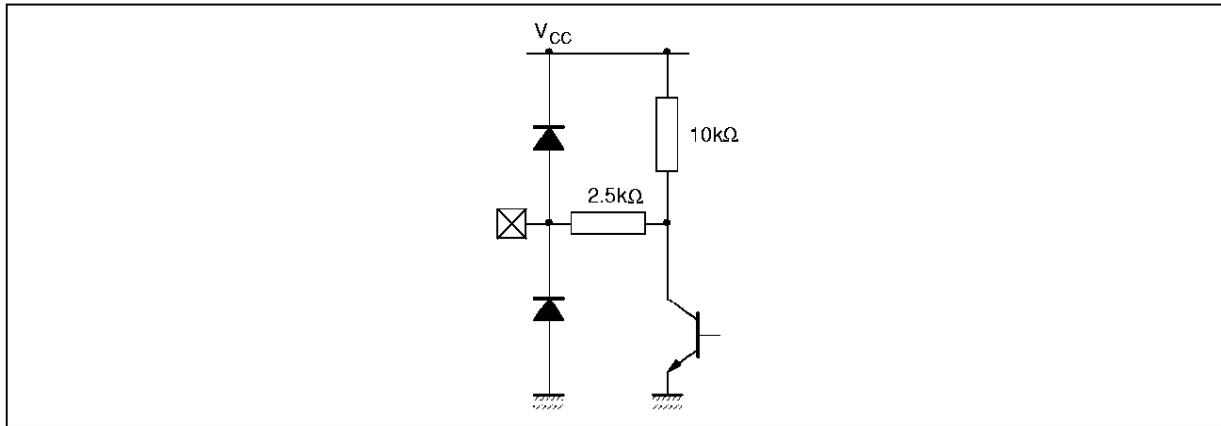

5725-11.EPS

Pin : V1-SP, V2-SP, V1-LP, V2-LP

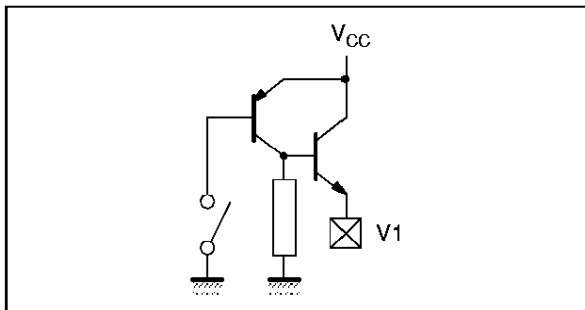

5725-12.EPS

Pin : RECIN

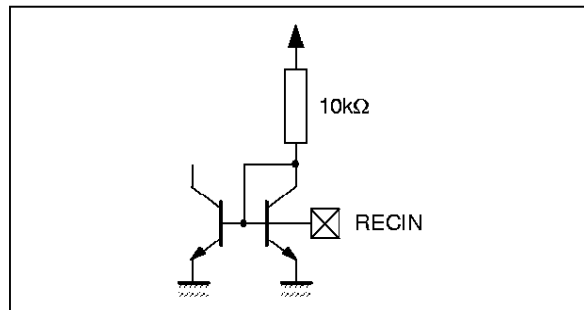

5725-13.EPS

PACKAGE MECHANICAL DATA
28 PINS - PLASTIC MICROPACKAGE

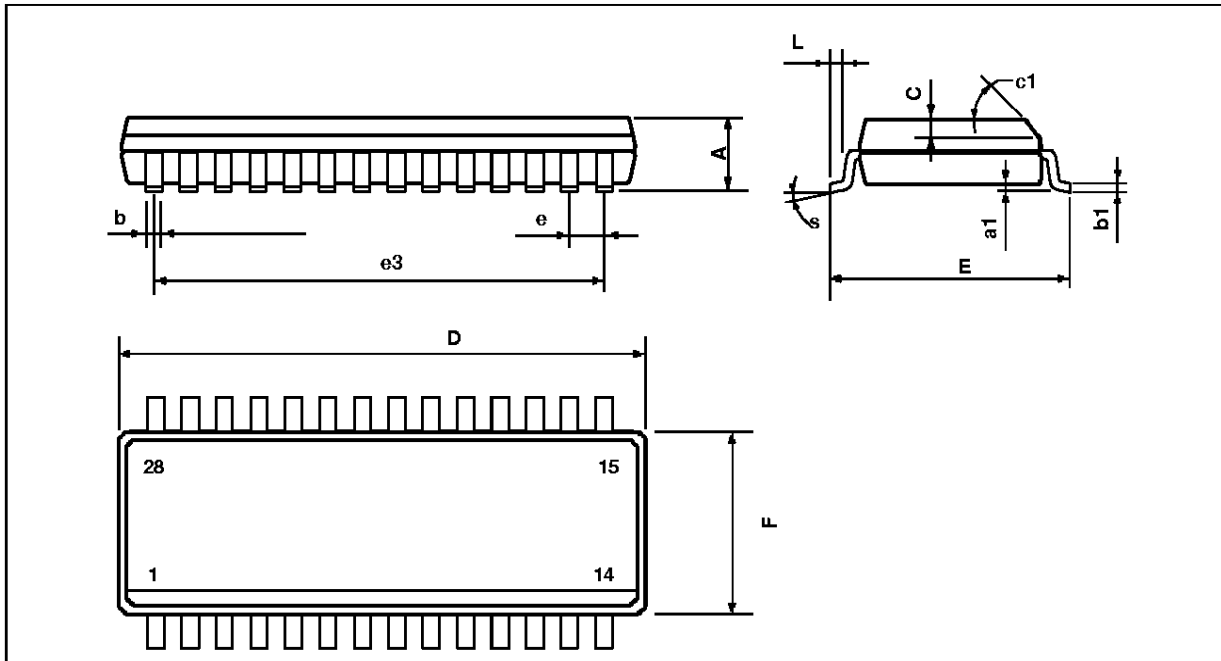

PM-S08 EPS

Dimensions	Millimeters			Inches		
	Min.	Typ.	Max.	Min.	Typ.	Max.
A			2.59			0.102
a1	0.05		0.20	0.002		0.008
b	0.31	0.41	0.51	0.012	0.016	0.020
b1	0.15		0.25	0.006		0.010
C		0.33			0.013	
D			18.13			0.714
E	10.11	10.31	10.51	0.399	0.406	0.414
e		1.27			0.050	
e3		16.51			0.65	
F	7.42	7.52	7.62	0.292	0.296	0.300
L	0.48	0.58	0.68	0.019	0.023	0.027
S	8° (max.)					

S02BB TBL

Information furnished is believed to be accurate and reliable. However, SGS-THOMSON Microelectronics assumes no responsibility for the consequences of use of such information nor for any infringement of patents or other rights of third parties which may result from its use. No licence is granted by implication or otherwise under any patent or patent rights of SGS-THOMSON Microelectronics. Specifications mentioned in this publication are subject to change without notice. This publication supersedes and replaces all information previously supplied. SGS-THOMSON Microelectronics products are not authorized for use as critical components in life support devices or systems without express written approval of SGS-THOMSON Microelectronics.

© 1994 SGS-THOMSON Microelectronics - All Rights Reserved

Purchase of I²C Components of SGS-THOMSON Microelectronics, conveys a license under the Philips I²C Patent. Rights to use these components in a I²C system, is granted provided that the system conforms to the I²C Standard Specifications as defined by Philips.

SGS-THOMSON Microelectronics GROUP OF COMPANIES

Australia - Brazil - China - France - Germany - Hong Kong - Italy - Japan - Korea - Malaysia - Malta - Morocco
The Netherlands - Singapore - Spain - Sweden - Switzerland - Taiwan - Thailand - United Kingdom - U.S.A.