

THIS DRAWING IS UNPUBLISHED. RELEASED FOR PUBLICATION
 © COPYRIGHT - By - ALL RIGHTS RESERVED.

LOC		DIST		REVISIONS			
P	LTR	DESCRIPTION		DATE	DWN	APVD	
	L1	REVISED PER ECO-11-004587		11MAR11	RK	HMR	

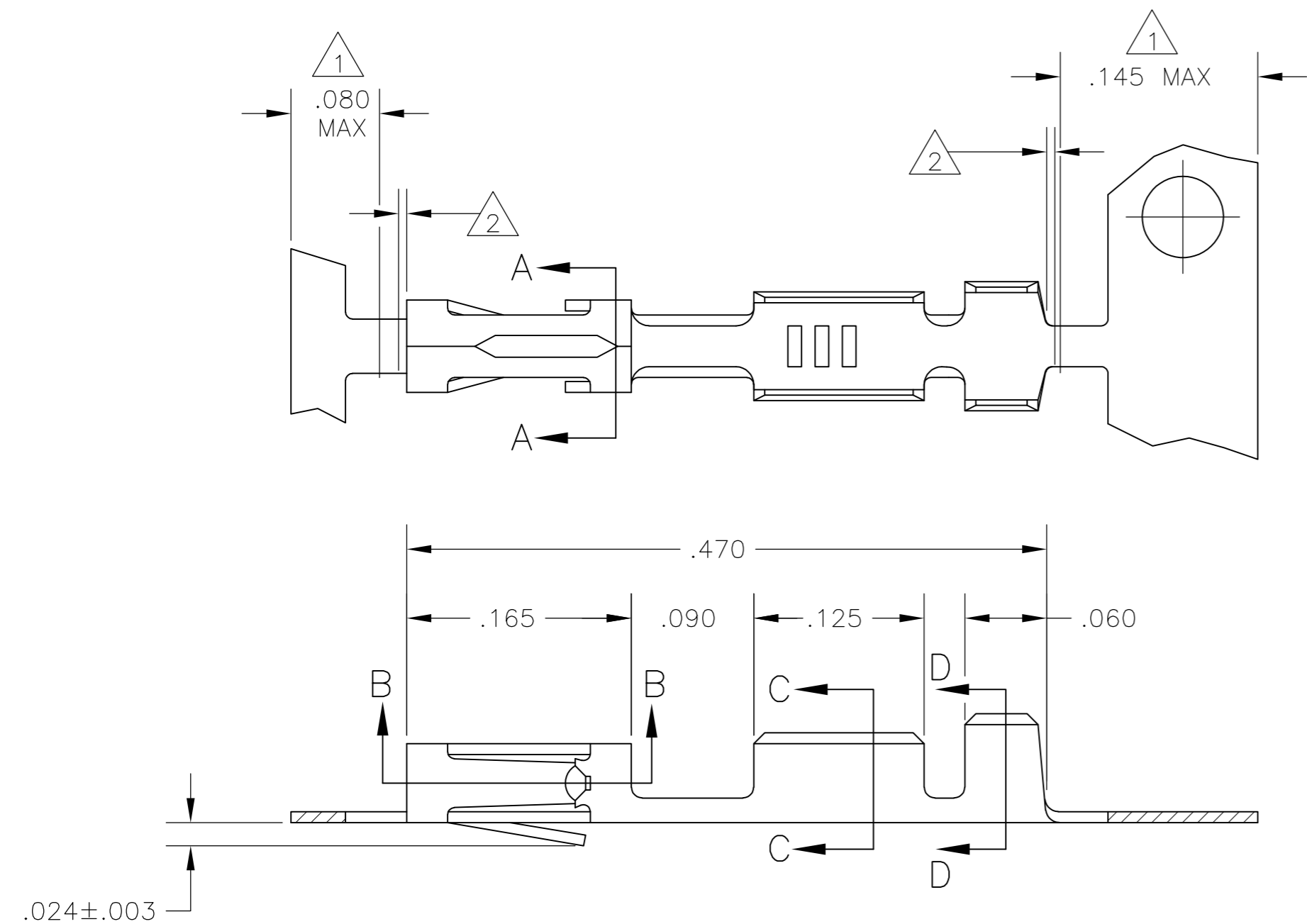

- 1 PLATING IS NOT REQUIRED IN THIS AREA.
- 2 .006 MAX LOOSE PIECE CUT-OFF.
- 3 POINT OF MEASUREMENT FOR PLATING THICKNESS, INSIDE BEAMS
- 4 .000050-.000150 PREPLATED BRIGHT TIN.
- 5 .000030 GOLD IN CONTACT AREA, GOLD FLASH ON THE REMAINDER, ALL OVER .000050 NICKEL.
- 6 .000030 GOLD OVER .000050 NICKEL ENTIRE TERMINAL.
- 7 .000050 GOLD OVER .000050 NICKEL ENTIRE TERMINAL.
- 8 .000015 GOLD IN CONTACT AREA, GOLD FLASH ON THE REMAINDER, ALL OVER .000050 NICKEL.
- 9 SHEAR EDGE ARE PERMITTED TO BE UNPLATED.
- 10 .000015 GOLD IN CONTACT AREA, .000050 NICKEL ON ENTIRE TERMINAL.
- 11 OBSOLETE PART NUMBER.

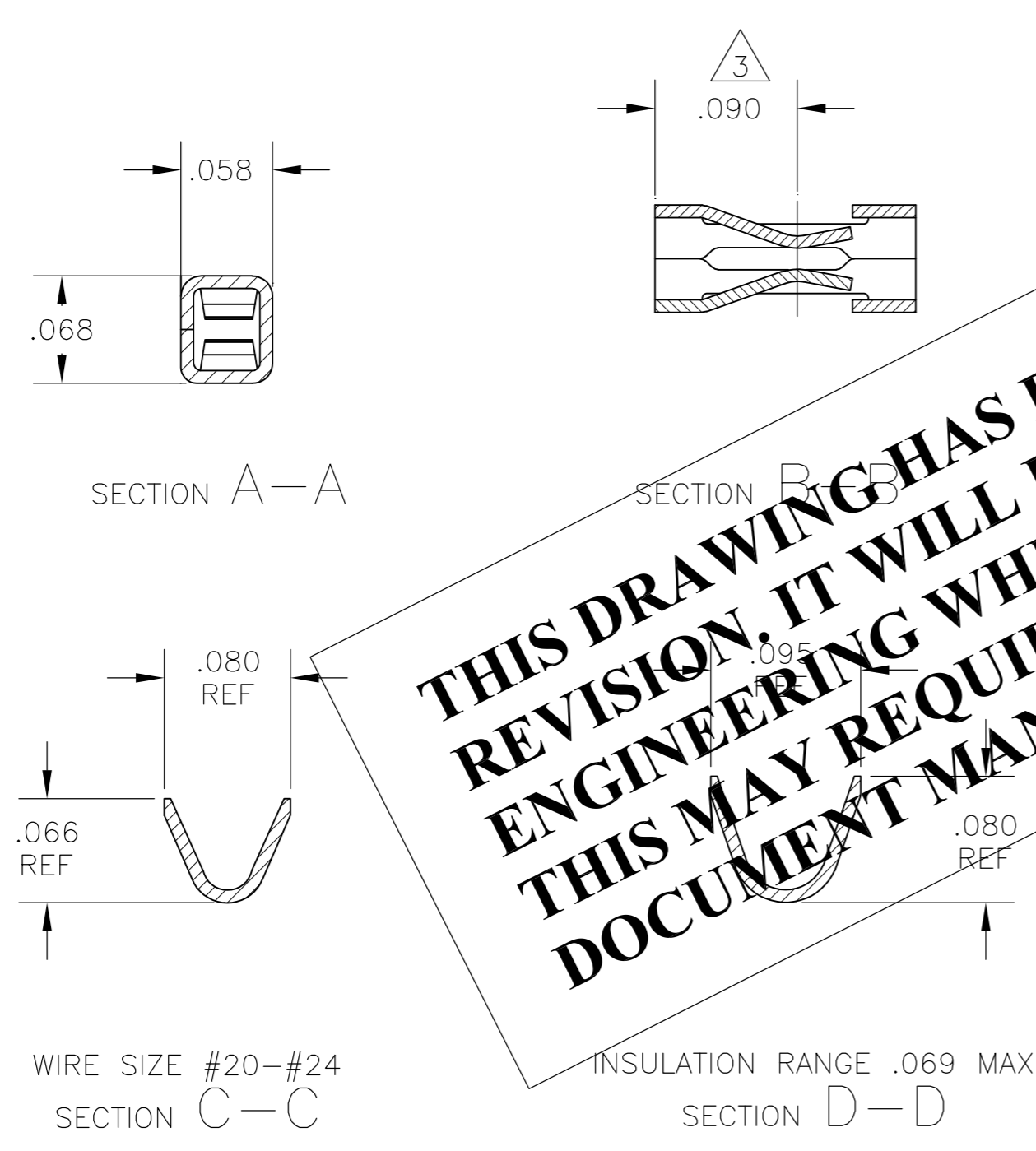

THIS DRAWING HAS BEEN TRANSLATED AND REFLECTS THE PREVIOUS REVISION. IT WILL REQUIRE A COMPLETE DRAWING CHECK BY PRODUCT ENGINEERING WHEN THE NEXT ECO CHANGE IS WRITTEN - THIS MAY REQUIRE A CHANGE TO THE REVISION OF THE DOCUMENT MANAGER FOLDER AND THIS DRAWING.

2-87309-5	OBSOLETE	2-87309-4
2- -3	OBSOLETE	2- -1
2- 11 -0	1- 11 -8	1 11 -9
1- 11 -7	11 -6	1 11 -2
1- 11 -6	11 -5	1 11 -1
1- 11 -5	11 -4	1 11 -0
1- -4	-3	-9
1-87309-3	87309-2	87309-8
LOOSE PIECE PART NUMBER	STANDARD APPLICATOR PART NUMBER	MINI APPLICATOR PART NUMBER
	FINISH	

DIMENSIONS:		TOLERANCES UNLESS OTHERWISE SPECIFIED:		DWN		TE Connectivity	
INCHES		0 PLC	± -	L D RINGLEY	28JAN85	NAME CONTACT, MOD V CRIMP SNAP-IN	
		1 PLC	± -	R J DAVIS	30JAN85		
		2 PLC	± -	APVD R J DAVIS	30JAN85	SIZE A2 CAGE CODE 00779 DRAWING NO C=87309	
		3 PLC	± .005	PRODUCT SPEC			
		4 PLC	± -	APPLICATION SPEC		RESTRICTED TO	
		ANGLES	± -				
MATERIAL	FINISH	WEIGHT		CUSTOMER DRAWING		SCALE 10:1	SHEET 1 of 1
PHOS. BRONZE .008 THICK	SEE TABLE						REV L1