

Unibal rod ends and spherical bearings are available in a variety of types and a full range of sizes. Following is a summary of types available.

- Standard
- Chromed ball
- Stainless Steel
- High Strength
- High Performance
- UNIFLON lined - self lubricating

4

This range of high quality components is manufactured by Schaublin SA in Switzerland, a company long associated with precision engineering, and for 35 years the design, development and manufacture of Unibal rod ends and spherical bearings. The Unibal trade mark has become synonymous with the best in quality and reliability, a reputation which derives from sound technical support based on extensive testing, close involvement with customers and the monitoring of quality at each stage of manufacture.

These are basic descriptions only. For further details of characteristics and selection please refer to the tables on pages 27 and 28.

selection

To ensure optimum life and reliability it is clearly important to select a rod end or spherical bearing suited to the application. The technical information which follows is provided as a guide to selection only, although it will be adequate for simple applications involving low loads, speeds, frequencies etc. For more demanding applications please contact our technical sales staff who will always be pleased to assist. Given sufficient information we can readily advise which Unibal product will be best suited to the application, and we can also provide an indication of the life expectancy.

A comprehensive Unibal catalogue containing full technical details is available on request.

The product information contained in this catalogue relates to components in standard production. In addition to these standard types, Schaublin are able to manufacture special versions to suit customers' requirements, and enquiries for such are welcome.



Table 1

SERIES	ROD ENDS	SPHERICALS	TYPE REFERENCE	CHARACTERISTICS	BEARING SURFACES	TABLE 2 REFERENCE
Standard Series	*	*	SMG, SFG SS	Simple mechanical applications with no special demands.	Steel / Bronze	1
Series 10	* *	*	SMG.10 SFG.10 SS.10	As standard but with chrome plated ball for reduced wear, corrosion resistance and higher operating speeds.	Steel / Bronze	2
Series 20	* *		SMG.20 SFG.20	As standard but offering a range of alternative threads including CETOP.	Steel / Bronze	3
Series 40	* *		SMG.40 SFG.40	High tensile steel housing to withstand high static loads.	Steel / Bronze	4
Series 45	* *	*	SMG.45 SFG.45 SS.45	Stainless steel housing and ball for use in corrosive environments	Steel / Bronze	5
Series 50/51/52	*		SMGM.50 /51/52	High performance series, for high resistance to static loads and vibration. Not suitable for high speeds.	Steel / Steel	6
Series 50/51/52 + UNIFLON®E	*		SMEM.50 /51/52	High performance series with UNIFLON®E lining. Self lubricating.	Steel / UNIFLON®E	7
UNIFLON®VV	*	*	SMVV, SFVV SSVV	UNIFLON®VV lining with polished ball for high operating speeds (8M/min). Self lubricating.	Steel / UNIFLON®VV	8
UNIFLON®E	*	*	SME, SFE SSE	UNIFLON®E lining with polished ball. Rated higher for loads and speeds (6m/min). Self lubricating.	Steel / UNIFLON®E	9
Series 40 + UNIFLON®E	* *		SME.40 SFE.40	High tensile steel, UNIFLON®E lined for high static & high dynamic loads. Self lubricating.	Steel / UNIFLON®E	10
Series 45 +UNIFLON®E	* *	*	SME.45 SFE.45 SSE.45	Stainless steel, UNIFLON®E lined for higher loads/speeds in corrosive environments.	St.steel / UNIFLON®E	11
Steel Spherical		*	SSA	Standard steel/steel bearings; good resistance to shockloads, static loads, vibrations.	Steel / Steel	12
Steel Spherical Series 10		*	SSA.10	As SSA but with chrome ball for reduced wear, corrosion resistance and higher operating speeds.	Steel / Steel	13
St. Steel Spherical Series 45		*	SSA.45	Stainless steel bearing with good resistance to static loads.	St.steel / St.steel	14
Steel Spherical Series 50		*	SSA.50	High performance series, no play for high resistance to static loads and improved dynamic performance.	Steel / Steel	15
Steel Spherical Series 50 + UNIFLON®E		*	SSE.50	High strength, no play, UNIFLON®E lined for exceptional load resistance and high speeds (9m/min). Self lubricating.	Steel / UNIFLON®E	16

Table 2 compares various types of rod end and spherical bearings under different operating conditions, and will enable an initial selection to be made. Size and load considerations should then be checked by reference to the product tables on the following pages.





The suitability and life expectancy of the chosen component can be checked by calculation if required; please contact the Huco sales office for assistance.

4

key

- Excellent, very well suited to indicated conditions.
- Average
- Not recommended for indicated conditions
- * Self-lubricating - maintenance free

Table 2

	Constant dynamic load	Alternating and/or pulsatory load	Shock loads vibration	Axial loads Axial shock loads	High operating speed	Frequent lubrication	No lubrication no maintenance	Temperature 100 – 250°C	Corrosive environment	Neoprene rubber seals sizes 6 – 22	Table 1 Reference
  	SMG, SFG	○	●	○	●	○	○	●	○	●	1
	SMG.10, SFG.10	○	●	○	●	○	○	●	○	●	2
	SMG.20, SFG.20	○	●	○	●	○	○	●	○	●	3
	SMG.40, SFG.40	○	●	●	●	○	○	●	○	●	4
	SMG.45, SFG.45	○	●	○	●	○	○	●	●	●	5
	SMGM.50/51/52	●	●	●	●	○	○	●	○	●	6
	SMEM.50/51/52	●	●	●	○	○	*	○	○	●	7
	SMVV, SFVV	●	○	○	○	●	*	○	○	●	8
	SME, SFE	●	○	○	○	●	*	○	○	●	9
	SME.40, SFE.40	●	○	○	○	○	*	○	○	●	10
	SME.45, SFE.45	●	○	○	○	●	*	○	○	●	11
	SS	○	●	○	●	○	○	●	○	○	1
	SS.10	○	●	○	●	○	○	●	○	○	2
	SS.45	○	●	○	●	○	○	●	○	○	5
	SSA	●	●	●	●	○	○	●	○	○	12
	SSA.10	●	●	●	●	○	○	●	○	○	13
	SSA.45	●	●	●	●	○	○	●	○	○	14
	SSA.50	●	●	●	●	○	○	●	○	○	15
	SSVV	●	○	○	●	○	*	○	○	○	8
	SSE	●	○	○	●	○	*	○	○	○	9
	SSE.45	●	○	○	●	○	*	○	○	○	11
	SSE.50	●	○	○	○	○	*	○	○	○	16

static loads

The product tables on the following pages refer to axial and radial static loads. The loads indicated are the maximum allowable.

safety factor

The allowable static loads given in our tables have been determined by dividing the static load at failure by 2.5

$$\text{Maximum allowable load} = \frac{\text{load at failure}}{2.5}$$

Axial and Radial static loads are defined in the following diagrams.

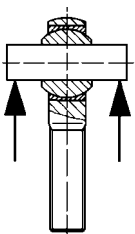

Radial static loads

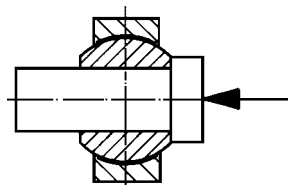

Axial static loads

axial static loads

Allowable axial loads are not stated for rod ends as in most circumstances the limiting condition will be determined not by the strength of the head, but by the resistance of the shank to bending. Where significant, axial loads should be determined and referred to us for advice.

bearing clearances

The clearances in rod ends and spherical bearings are related to size, as indicated in the following table. In all cases, the clearances indicated are the maximum to be expected.

Clearance mm	2 – 6	8 – 12	14 – 18	20 – 22	25 – 30	35 – 50
axial	0.09	0.10	0.12	0.15	0.18	0.20
radial	0.03	0.04	0.05	0.06	0.08	0.09

This table does not apply to the types listed below which are produced with minimum clearance to provide a tight fit.

SMG.40, SFG.40
SMGM.50/51/52
SSA.50

SMEM.50/51/52
SMVV, SFVV
SME, SFE
SME.40, SFE.40
SSVV
SSE
SSE.50

angles of misalignment

The angles of misalignment (α) shown are valid for all rod end and spherical bearings.

The angle (α) varies depending upon the type of assembly. Table 3 indicates the maximum angular misalignment possible for the three assemblies encountered most frequently. Angles shown are rounded to the nearest whole number.

The formulæ shown in Table 4 may be used to calculate the angle α for other types of assembly

Table 3

Size	Value of α angle		
	α_1	α_2	α_3
2	8°	16°	33°
3	8°	15°	33°
4	8°	14°	31°
5	8°	13°	30°
6	8°	13°	30°
8	8°	14°	25°
10	8°	14°	25°
12	8°	13°	25°
14	10°	16°	24°
16	9°	15°	24°
18	9°	15°	24°
20	9°	15°	24°
22	10°	15°	23°
25	10°	15°	23°
30	11°	17°	24°
35	8°	14°	23°
40	8°	14°	22°
45	7°	12°	22°
50	7°	12°	22°

Table 4

Calculation formulæ

$$\alpha_1 = \tan^{-1} \left(\frac{W - H}{D} \right)$$

$$\alpha_2 = \cos^{-1} \left(\frac{H}{E} \right) - \tan^{-1} \left(\frac{O}{W} \right)$$

$$\alpha_3 = \cos^{-1} \left(\frac{H}{E} \right) - \sin^{-1} \left(\frac{B}{E} \right)$$

Unibal NEOPRENE PROTECTIVE COVERS

Material : Neoprene, to NF T 46-018 Standard.

Temperature range : -30°C to +120°C

Good resistance to : oil, grease, chemical agents, sea water, tropical climate

Not recommended for : permanent contact with rust agents.
Application where the ball is completely rotated or where there are high running speeds.



Protective Covers

Order Code	Rod End Size
SPR1	6 - 8
SPR2	10 - 12
SPR3	14 - 18
SPR4	20 - 25

Spacers

Order Code	ØA	ØB	ØC	D	E	α
SBD 06	11	6	8.7	6	4	13°
SBD 08	12	8	10.3	6	4	14°
SBD 10	14	10	12.5	6	4	14°
SBD 12	17	12	15	8	6	13°
SBD 14	19	14	16.8	8	6	16°
SBD 18	25	18	21.8	8	6	15°

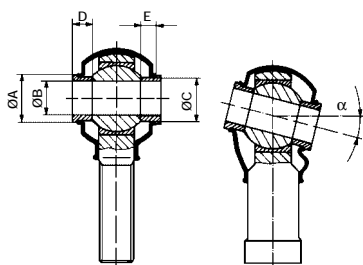

Unibal MALE ROD ENDS

For left-handed threads, please add the suffix "L" to the order code e.g., SMG.00.12.L.

The letter 'G' in the order code indicates that a lubrication nipple is fitted.

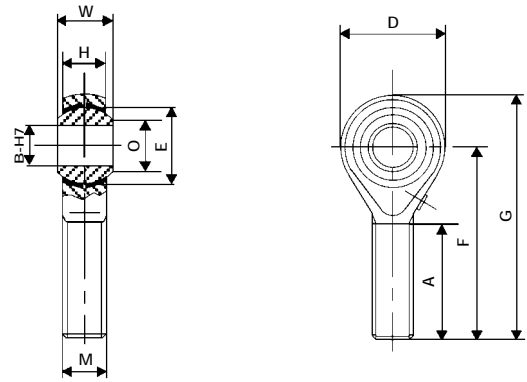

4

Series : Standard

Requires Lubrication

Order Code	Size	Static Load (kN)	Thread	×	Pitch	A	B	D	F	G	H	O	W	Ball dia E	Weight (g)
SMF.00.02	02	0.40	M2	×	0.4	9	2	9	18	22.5	3.6	3.60	4.8	6.00	2
SMF.00.03	03	1.20	M3	×	0.5	15	3	12	27	33	4.5	5.18	6	7.93	5
SMF.00.04	04	2.00	M4	×	0.7	18	4	14	30	37	5.25	6.46	7	9.52	9
SMF.00.05	05	3.40	M5	×	0.8	20	5	16	33	41	6	7.71	8	11.11	12
SMF.00.06	06	4.90	M6	×	1	22	6	18	36	45	6.75	8.96	9	12.70	18
SMG.00.08	08	8.30	M8	×	1.25	25	8	22	42	53	9	10.40	12	15.88	35
SMG.00.10	10	12.70	M10	×	1.5	29	10	26	48	61	10.5	12.92	14	19.05	57
SMG.00.12	12	16.70	M12	×	1.75	33	12	30	54	69	12	15.43	16	22.23	87
SMG.00.14	14	20.60	M14	×	2	36	14	34	60	77	13.5	16.86	19	25.40	120
SMG.00.16	16	25.00	M16	×	2	40	16	38	66	85	15	19.39	21	28.58	170
SMG.00.18	18	29.40	M18	×	1.5	44	18	42	72	93	16.5	21.89	23	31.75	240
SMG.00.20	20	34.30	M20	×	1.5	47	20	46	78	101	18	24.38	25	34.92	320
SMG.00.22	22	41.20	M22	×	1.5	51	22	50	84	109	20	25.84	28	38.10	420
SMG.00.25	25	50.00	M24	×	2	57	25	56	94	122	22	29.60	31	42.85	580
SMG.00.30	30	66.70	M30	×	2	66	30	66	110	143	25	34.80	37	50.80	980

Series : 10 Chromed Ball

Requires Lubrication

Order Code	Size	Static Load (kN)	Thread	×	Pitch	A	B	D	F	G	H	O	W	Ball dia E	Weight (g)
SMF.10.03	03	1.20	M3	×	0.5	15	3	12	27	33	4.5	5.18	6	7.93	5
SMF.10.04	04	2.00	M4	×	0.7	18	4	14	30	37	5.25	6.46	7	9.52	9
SMF.10.05	05	3.40	M5	×	0.8	20	5	16	33	41	6	7.71	8	11.11	12
SMF.10.06	06	4.90	M6	×	1	22	6	18	36	45	6.75	8.96	9	12.70	18
SMG.10.08	08	8.30	M8	×	1.25	25	8	22	42	53	9	10.40	12	15.88	35
SMG.10.10	10	12.70	M10	×	1.5	29	10	26	48	61	10.5	12.92	14	19.05	57
SMG.10.12	12	16.70	M12	×	1.75	33	12	30	54	69	12	15.43	16	22.23	87
SMG.10.14	14	20.60	M14	×	2	36	14	34	60	77	13.5	16.86	19	25.40	120
SMG.10.16	16	25.00	M16	×	2	40	16	38	66	85	15	19.39	21	28.58	170
SMG.10.18	18	29.40	M18	×	1.5	44	18	42	72	93	16.5	21.89	23	31.75	240
SMG.10.20	20	34.30	M20	×	1.5	47	20	46	78	101	18	24.38	25	34.92	320
SMG.10.22	22	41.20	M22	×	1.5	51	22	50	84	109	20	25.84	28	38.10	420
SMG.10.25	25	50.00	M24	×	2	57	25	56	94	122	22	29.60	31	42.85	580
SMG.10.30	30	66.70	M30	×	2	66	30	66	110	143	25	34.80	37	50.80	980

Materials:

Housing: Sizes 2 - 12 - C22 or C35 Pb steel, zinc plated and passivated
 Sizes 14 - 30 - C35 steel, zinc plated and passivated

Ball: Standard - hardened ground, polished 100 Cr6 ball bearing steel
 Series 10 - hardened ground, hard chrome plated 100 Cr6 ball bearing steel

Inserts: Sizes 2 - 16 - Cu Zn 40 Mn Pb bronze
 Sizes 18 - 30 - Gc - Cu Sn7 Zn Pb bronze

Unibal MALE ROD ENDS

For left-handed threads, please add the suffix "L" to the order code e.g., SMG.40.08.L.

The letter 'G' in the order code indicates that a lubrication nipple is fitted.

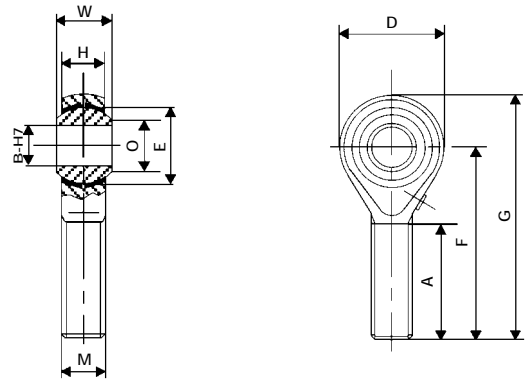

Series : 20 - As Standard - With Alternative Thread Pitch

Requires Lubrication

Order Code	Size	Static Load (kN)	Thread	×	Pitch	A	B	D	F	G	H	O	W	Ball dia E	Weight (g)
SMG.20.08	08	8.30	M8	×	1	25	8	22	42	53	9	10.40	12	15.88	35
SMG.20.10	10	12.70	M10	×	1	29	10	26	48	61	10.5	12.92	14	19.05	57
SMG.22.10	10	12.70	Cetop M10	×	1.25	29	10	26	48	61	10.5	12.92	14	19.05	57
SMG.22.12	12	16.70	Cetop M12	×	1.25	33	12	30	54	69	12	15.43	16	22.23	87
SMG.20.12	12	16.70	M12	×	1.5	33	12	30	54	69	12	15.43	16	22.23	87
SMG.20.14	14	20.60	M14	×	1.5	36	14	34	60	77	13.5	16.86	19	25.40	120
SMG.20.16	16	25.00	M16	×	1.5	40	16	38	66	85	15	19.39	21	28.58	170
SMG.20.18	18	29.40	M18	×	2.5	44	18	42	72	93	16.5	21.89	23	31.75	240
SMG.20.20	20	34.30	M20	×	2.5	47	20	46	78	101	18	24.38	25	34.92	320
SMG.20.22	22	41.20	M22	×	2.5	51	22	50	84	109	20	25.84	28	38.10	420
SMG.20.25	25	50.00	M24	×	3	57	25	56	94	122	22	29.60	31	42.85	580
SMG.20.30	30	66.70	M30	×	3.5	66	30	66	110	143	25	34.80	37	50.80	980

Materials: As Standard series.

Series : 40 High Strength - Tight Bearing Fit

Requires Lubrication

Order Code	Size	Static Load (kN)	Thread	×	Pitch	A	B	D	F	G	H	O	W	Ball dia E	Weight (g)
SMF.40.05	05	6.90	M5	×	0.8	20	5	16	33	41	6	7.71	8	11.11	12
SMF.40.06	06	9.80	M6	×	1	22	6	18	36	45	6.75	8.96	9	12.70	18
SMG.40.08	08	16.70	M8	×	1.25	25	8	22	42	53	9	10.40	12	15.88	35
SMG.40.10	10	25.50	M10	×	1.5	29	10	26	48	61	10.5	12.92	14	19.05	57
SMG.40.12	12	33.30	M12	×	1.75	33	12	30	54	69	12	15.43	16	22.23	87
SMG.40.14	14	41.20	M14	×	2	36	14	34	60	77	13.5	16.86	19	25.40	120
SMG.40.16	16	50.00	M16	×	2	40	16	38	66	85	15	19.39	21	28.58	170
SMG.40.18	18	58.90	M18	×	1.5	44	18	42	72	93	16.5	21.89	23	31.75	240
SMG.40.20	20	68.70	M20	×	1.5	47	20	46	78	101	18	24.38	25	34.92	320
SMG.40.22	22	82.40	M22	×	1.5	51	22	50	84	109	20	25.84	28	38.10	420
SMG.40.25	25	100.10	M24	×	2	57	25	56	94	122	22	29.60	31	42.85	580
SMG.40.30	30	133.40	M30	×	2	66	30	66	110	143	25	34.80	37	50.80	980

Materials:

Housing: C45 treated (or similar) steel, zinc plated and yellow passivated

Ball: Hardened ground, polished 100 Cr 6 ball bearing steel

Inserts: Gc-Cu Sn7 Zn Pb bronze

Unibal MALE ROD ENDS

- High performance
- Magnaflux control

For left-handed threads, please add the suffix "L" to the order code e.g., SMG.50.08.L.

The letter 'G' in the order code indicates that a lubrication nipple is fitted.

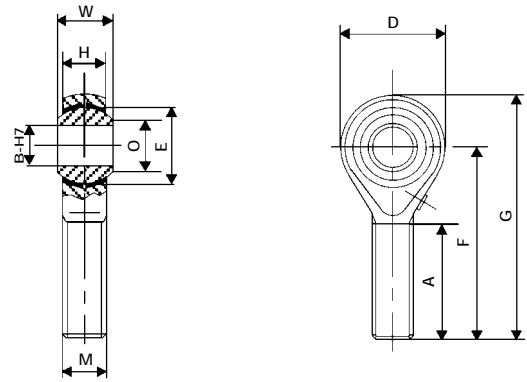

4

Series : 50 Standard - High Performance Model

Requires Lubrication

Order Code	Size	Static Load (kN)	Thread × Pitch	A	B	D	F	G	H	O	W	Ball dia E	Weight (g)
SMG.50.05	05	8.1	M5 × 0.8	20	5	16	33	41	6	7.71	8	11.11	12
SMG.50.06	06	11.2	M6 × 1	22	6	18	36	45	6.75	8.96	9	12.70	18
SMG.50.08	08	20.6	M8 × 1.25	25	8	22	42	53	9	10.40	12	15.88	35
SMG.50.10	10	31.4	M10 × 1.5	29	10	26	48	61	10.5	12.92	14	19.05	57
SMG.50.12	12	39.2	M12 × 1.75	33	12	30	54	69	12	15.43	16	22.23	87
SMG.50.14	14	48.1	M14 × 2	36	14	34	60	77	13.5	16.86	19	25.40	120
SMG.50.16	16	58.9	M16 × 2	40	16	38	66	85	15	19.39	21	28.58	170
SMG.50.18	18	70.6	M18 × 1.5	44	18	42	72	93	16.5	21.89	23	31.75	240

Series : 51 High Performance Model - Fine Thread Series

Requires Lubrication

Order Code	Size	Static Load (kN)	Thread × Pitch	A	B	D	F	G	H	O	W	Ball dia E	Weight (g)
SMG.51.05	05	8.1	M5 × 0.5	20	5	16	33	41	6	7.71	8	11.11	12
SMG.51.06	06	11.2	M6 × 0.75	22	6	18	36	45	6.75	8.96	9	12.70	18
SMG.51.08	08	20.6	M8 × 1	25	8	22	42	53	9	10.40	12	15.88	35
SMG.51.10	10	31.4	M10 × 1	29	10	26	48	61	10.5	12.92	14	19.05	57
SMG.51.12	12	39.2	M12 × 1.5	33	12	30	54	69	12	15.43	16	22.23	87
SMG.51.14	14	48.1	M14 × 1.5	36	14	34	60	77	13.5	16.86	19	25.40	120
SMG.51.16	16	58.9	M16 × 1.5	40	16	38	66	85	15	19.39	21	28.58	170

Series : 52 High Performance Model - Small Bore Ball/Fine Threads*

Requires Lubrication

Order Code	Size	Static Load (kN)	Thread × Pitch	A	B	D	F	G	H	O	W	Ball dia E	Weight (g)
SMG.52.10	10	31.4	M10 × 1	29	8	26	48	61	10.5	12.92	14	19.05	62
SMG.52.12	12	39.2	M12 × 1.5	33	10	30	54	69	12	15.43	16	22.23	90
SMG.52.14	14	48.1	M14 × 1.5	36	12	34	60	77	13.5	16.86	19	25.40	130
SMG.52.16	16	58.9	M16 × 1.5	40	14	38	66	85	15	19.39	21	28.58	185
SMG.52.18	18	70.6	M18 × 1.5	44	16	42	72	93	16.5	21.89	23	31.7	250

*bore of ball is 2mm less than diameter of the thread

Materials:

Housing: High performance 34 Cr Ni Mo 6 steel, carbonised and oiled

Ball: Hardened ground, polished hard chrome plated 100 Cr6 ball bearing steel

Inserts: Stainless steel x 10 Cr Ni S 189
Manufactured with reduced play and Magnaflux control

- High performance
- Magnaflux control
- Uniflon®E self-lubricating

For left-handed threads, please add the suffix "L" to the order code e.g., SME.50.08.L.

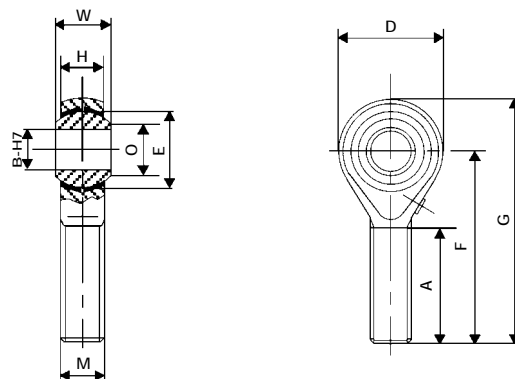

Series : 50 Standard - High Performance Model

Order Code	Size	Static Load (kN)	Thread × Pitch	A	B	D	F	G	H	O	W	Self-Lubricating	
												Ball dia E	Weight (g)
SME.50.05	05	6.1	M5 × 0.8	20	5	16	33	41	6	7.71	8	11.11	12
SME.50.06	06	8.6	M6 × 1	22	6	18	36	45	6.75	8.96	9	12.70	18
SME.50.08	08	15.2	M8 × 1.25	25	8	22	42	53	9	10.40	12	15.88	35
SME.50.10	10	23.2	M10 × 1.5	29	10	26	48	61	10.5	12.92	14	19.05	57
SME.50.12	12	29.0	M12 × 1.75	33	12	30	54	69	12	15.43	16	22.23	87
SME.50.14	14	35.5	M14 × 2	36	14	34	60	77	13.5	16.86	19	25.40	120
SME.50.16	16	43.5	M16 × 2	40	16	38	66	85	15	19.39	21	28.58	170
SME.50.18	18	52.2	M18 × 1.5	44	18	42	72	93	16.5	21.89	23	31.75	240

Series : 51 High Performance Model - Fine Thread Series

Order Code	Size	Static Load (kN)	Thread × Pitch	A	B	D	F	G	H	O	W	Self-Lubricating	
												Ball dia E	Weight (g)
SME.51.05	05	6.1	M5 × 0.5	20	5	16	33	41	6	7.71	8	11.11	12
SME.51.06	06	8.6	M6 × 0.75	22	6	18	36	45	6.75	8.96	9	12.70	18
SME.51.08	08	15.2	M8 × 1	25	8	22	42	53	9	10.40	12	15.88	35
SME.51.10	10	23.2	M10 × 1	29	10	26	48	61	10.5	12.92	14	19.05	57
SME.51.12	12	29.0	M12 × 1.5	33	12	30	54	69	12	15.43	16	22.23	87
SME.51.14	14	35.5	M14 × 1.5	36	14	34	60	77	13.5	16.86	19	25.40	120
SME.51.16	16	43.5	M16 × 1.5	40	16	38	66	85	15	19.39	21	28.58	170

Series : 52 High Performance Model - Small Bore Ball/Fine Threads*

Order Code	Size	Static Load (kN)	Thread × Pitch	A	B	D	F	G	H	O	W	Self-Lubricating	
												Ball dia E	Weight (g)
SME.52.10	10	23.2	M10 × 1	29	8	26	48	61	10.5	12.92	14	19.05	62
SME.52.12	12	29.0	M12 × 1.5	33	10	30	54	69	12	15.43	16	22.23	90
SME.52.14	14	35.5	M14 × 1.5	36	12	34	60	77	13.5	16.86	19	25.40	130
SME.52.16	16	43.5	M16 × 1.5	40	14	38	66	85	15	19.39	21	28.58	185
SME.52.18	18	52.2	M18 × 1.5	44	16	42	72	93	16.5	21.89	23	31.75	250

*bore of ball is 2mm less than diameter of the thread

Materials:

Housing: High performance 34 Cr Ni Mo 6 (or similar) steel, carbonised and oiled or zinc plated and yellow passivated

Ball: Hardened ground, polished hard chrome plated 100 Cr6 ball bearing steel

Inserts: Stainless steel x 10 Cr Ni S 189 Uniflon®E
Manufactured with reduced play and Magnaflux control

Unibal MALE ROD ENDS

Uniflon liners between the ball and race eliminate the need for lubrication.

For left-handed threads, please add the suffix "L" to the order code e.g., SME.40.06.L.

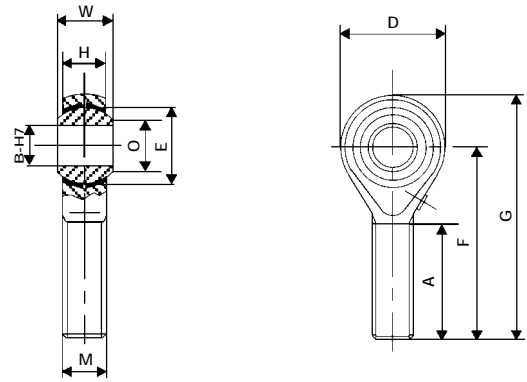

4

Series : Uniflon®E (Max Speed 6m/min)

Self-Lubricating

Order Code	Size	Static Load (kN)	Thread × Pitch	A	B	D	F	G	H	O	W	Ball dia E	Weight (g)
SME.00.03	03	0.90	M3 × 0.5	15	3	12	27	33	4.5	5.18	6	7.93	5
SME.00.04	04	1.50	M4 × 0.7	18	4	14	30	37	5.25	6.46	7	9.52	9
SME.00.05	05	2.60	M5 × 0.8	20	5	16	33	41	6	7.71	8	11.11	12
SME.00.06	06	3.70	M6 × 1	22	6	18	36	45	6.75	8.96	9	12.70	18
SME.00.08	08	6.40	M8 × 1.25	25	8	22	42	53	9	10.40	12	15.88	35
SME.00.10	10	9.70	M10 × 1.5	29	10	26	48	61	10.5	12.92	14	19.05	57
SME.00.12	12	12.80	M12 × 1.75	33	12	30	54	69	12	15.43	16	22.23	87
SME.00.14	14	15.80	M14 × 2	36	14	34	60	77	13.5	16.86	19	25.40	120
SME.00.16	16	19.20	M16 × 2	40	16	38	66	85	15	19.39	21	28.58	170
SME.00.18	18	22.60	M18 × 1.5	44	18	42	72	93	16.5	21.89	23	31.75	240
SME.00.20	20	26.40	M20 × 1.5	47	20	46	78	101	18	24.38	25	34.92	320
SME.00.22	22	31.70	M22 × 1.5	51	22	50	84	109	20	25.84	28	38.10	420
SME.00.25	25	38.50	M24 × 2	57	25	56	94	122	22	29.60	31	42.85	580
SME.00.30	30	51.30	M30 × 2	66	30	66	110	143	25	34.80	37	50.80	980

Series : Uniflon®VV (Max Speed 8m/min)

Self-Lubricating

Sizes and ratings as Uniflon®E Series

To specify VV series, change order code to SMV, eg SMV.00.08

Materials:

Housing: Sizes 3 - 12 - C35 Pb steel, zinc plated and passivated
 Sizes 14 - 30 - C35 steel, zinc plated and passivated

Ball: Hardened ground, polished 100 Cr6 ball bearing steel

Inserts: Sizes 3 - 16 - Cu Zu 40 Mn Pb bronze, Uniflon E or Uniflon VV
 Sizes 14 - 30 - Cu Zu 40 Pb 3 bronze, Uniflon E or Uniflon VV

Series : 40 Uniflon®E High Strength - Tight Bearing Fit

Self-Lubricating

Order Code	Size	Static Load (kN)	Thread × Pitch	A	B	D	F	G	H	O	W	Ball dia E	Weight (g)
SME.40.05	05	5.30	M5 × 0.8	20	5	16	33	41	6	7.71	8	11.11	12
SME.40.06	06	7.50	M6 × 1	22	6	18	36	45	6.75	8.96	9	12.70	18
SME.40.08	08	10.30	M8 × 1.25	25	8	22	42	53	9	10.40	12	15.88	35
SME.40.10	10	19.60	M10 × 1.5	29	10	26	48	61	10.5	12.92	14	19.05	57
SME.40.12	12	25.60	M12 × 1.75	33	12	30	54	69	12	15.43	16	22.23	87
SME.40.14	14	31.70	M14 × 2	36	14	34	60	77	13.5	16.86	19	25.40	120
SME.40.16	16	38.50	M16 × 2	40	16	38	66	85	15	19.39	21	28.58	170
SME.40.18	18	45.30	M18 × 1.5	44	18	42	72	93	16.5	21.89	23	31.75	240
SME.40.20	20	52.80	M20 × 1.5	47	20	46	78	101	18	24.38	25	34.92	320
SME.40.22	22	63.40	M22 × 1.5	51	22	50	84	109	20	25.84	28	38.10	420
SME.40.25	25	77.00	M24 × 2	57	25	56	94	122	22	29.60	31	42.85	580
SME.40.30	30	102.70	M30 × 2	66	30	66	110	143	25	34.80	37	50.80	980

Materials:

Housing: C45 treated steel, zinc plated and yellow passivated

Ball: Hardened ground, polished 100 Cr6 ball bearing steel

Rack: C35 Pb steel, zinc plated and passivated Uniflon®E

Unibal MALE ROD ENDS

- Stainless steel series

For left-handed threads, please add the suffix "L" to the order code e.g., SME.45.08.L.

The letter 'G' in the order code indicates that a lubrication nipple is fitted.

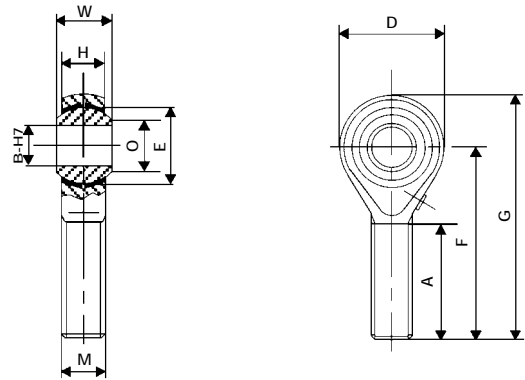

Series : 45 Stainless Steel, Standard

Requires Lubrication

Order Code	Size	Static Load (kN)	Thread	×	Pitch	A	B	D	F	G	H	O	W	Ball dia E	Weight (g)
SMF.45.03	03	0.70	M3	×	0.5	15	3	12	27	33	4.5	5.18	6	7.93	5
SMF.45.04	04	1.20	M4	×	0.7	18	4	14	30	37	5.25	6.46	7	9.52	9
SMF.45.05	05	2.00	M5	×	0.8	20	5	16	33	41	6	7.71	8	11.11	13
SMF.45.06	06	2.80	M6	×	1	22	6	18	36	45	6.75	8.96	9	12.70	18
SMG.45.08	08	5.20	M8	×	1.25	25	8	22	42	53	9	10.40	12	15.88	35
SMG.45.10	10	7.80	M10	×	1.5	29	10	26	48	61	10.5	12.92	14	19.05	57
SMG.45.12	12	10.00	M12	×	1.75	33	12	30	54	69	12	15.43	16	22.23	87
SMG.45.14	14	12.30	M14	×	2	36	14	34	60	77	13.5	16.86	19	25.40	120
SMG.45.16	16	14.90	M16	×	2	40	16	38	66	85	15	19.39	21	28.58	170
SMG.45.18	18	17.80	M18	×	1.5	44	18	42	72	93	16.5	21.89	23	31.75	240
SMG.45.20	20	20.90	M20	×	1.5	47	20	46	78	101	18	24.38	25	34.92	320
SMG.45.22	22	24.60	M22	×	1.5	51	22	50	84	109	20	25.84	28	38.10	420
SMG.45.25	25	30.00	M24	×	2	57	25	56	94	122	22	29.60	31	42.85	580
SMG.45.30	30	39.70	M30	×	2	66	30	66	110	143	25	34.80	37	50.80	980

Series : 45 Uniflon®E Stainless Steel

Self-Lubricating

Order Code	Size	Static Load (kN)	Thread	×	Pitch	A	B	D	F	G	H	O	W	Ball dia E	Weight (g)
SME.45.03	03	0.50	M3	×	0.5	15	3	12	27	33	4.5	5.18	6	7.93	5
SME.45.04	04	0.90	M4	×	0.7	18	4	14	30	37	5.25	6.46	7	9.52	9
SME.45.05	05	1.50	M5	×	0.8	20	5	16	33	41	6	7.71	8	11.11	13
SME.45.06	06	2.10	M6	×	1	22	6	18	36	45	6.75	8.96	9	12.70	18
SME.45.08	08	4.00	M8	×	1.25	25	8	22	42	53	9	10.40	12	15.88	35
SME.45.10	10	6.00	M10	×	1.5	29	10	26	48	61	10.5	12.92	14	19.05	57
SME.45.12	12	7.70	M12	×	1.75	33	12	30	54	69	12	15.43	16	22.23	87
SME.45.14	14	9.40	M14	×	2	36	14	34	60	77	13.5	16.86	19	25.40	120
SME.45.16	16	11.40	M16	×	2	40	16	38	66	85	15	19.39	21	28.58	170
SME.45.18	18	13.70	M18	×	1.5	44	18	42	72	93	16.5	21.89	23	31.75	240
SME.45.20	20	16.00	M20	×	1.5	47	20	46	78	101	18	24.38	25	34.92	320
SME.45.22	22	18.90	M22	×	1.5	51	22	50	84	109	20	25.84	28	38.10	420
SME.45.25	25	23.10	M24	×	2	57	25	56	94	122	22	29.60	31	42.85	580
SME.45.30	30	30.50	M30	×	2	66	30	66	110	143	25	34.80	37	50.80	980

Materials:

Housing: Stainless steel x 10 Cr Ni S 189 (A151 303)

Ball: Stainless steel x 46 Cr 13 (A141 420)

Inserts: Standard type : Gc Cu Sn 7 Zn Pb bronze

Race: Self-lubricating type : x 10 Cr Ni S 189 (A151 303) Uniflon®E

Unibal FEMALE ROD ENDS

For left-handed threads, please add the suffix "L" to the order code e.g., SFG.10.08.L.

The letter 'G' in the order code indicates that a lubrication nipple is fitted.

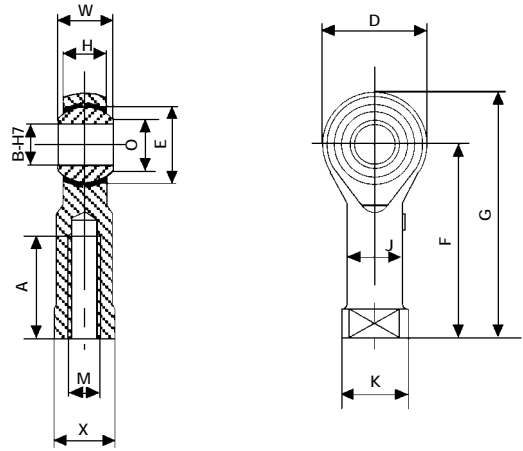

4

Series : Standard

Requires Lubrication

Order Code	Size	Static Load (kN)	Thread	×	Pitch	A	B	D	F	G	H	J	K	L	O	W	X	Ball dia Weight	
																		E	(g)
SFF.00.02	02	1.90	M2	×	0.4	7	2	9	16	20.5	3.6	3.8	4.5	2.5	3.60	4.8	4.5	6.00	3
SFF.00.03	03	3.60	M3	×	0.5	10	3	12	21	27	4.5	5	6.5	3	5.18	6	5.5	7.93	7
SFF.00.04	04	4.50	M4	×	0.7	12	4	14	24	31	5.25	6.5	8.5	3.5	6.46	7	7	9.52	11
SFF.00.05	05	5.60	M5	×	0.8	14	5	16	27	35	6	7.5	9.5	4	7.71	8	8	11.11	14
SFF.00.06	06	6.90	M6	×	1	14	6	18	30	39	6.75	9.5	12	5	8.96	9	10	12.70	22
SFG.00.08	08	9.80	M8	×	1.25	17	8	22	36	47	9	12.5	16	5	10.40	12	13	15.88	38
SFG.00.10	10	13.20	M10	×	1.5	20	10	26	43	56	10.5	15	19	6.5	12.92	14	16	19.05	70
SFG.00.12	12	16.70	M12	×	1.75	22	12	30	50	65	12	17.5	22	6.5	15.43	16	18	22.23	120
SFG.00.14	14	20.60	M14	×	2	27	14	34	57	74	13.5	20	25	8	16.86	19	21	25.40	150
SFG.00.16	16	25.00	M16	×	2	33	16	38	64	83	15	22	27	8	19.39	21	24	28.58	200
SFG.00.18	18	29.40	M18	×	1.5	36	18	42	71	92	16.5	25	31	10	21.89	23	27	31.75	280
SFG.00.20	20	34.30	M20	×	1.5	40	20	46	77	100	18	27.5	34	10	24.38	25	30	34.92	370
SFG.00.22	22	41.20	M22	×	1.5	43	22	50	84	109	20	30	37	12	25.84	28	34	38.10	480
SFG.00.25	25	50.00	M24	×	2	48	25	56	94	122	22	33.5	42	12	29.60	31	36	42.85	670
SFG.00.30	30	66.70	M30	×	2	56	30	66	110	143	25	40	50	15	34.80	37	46	50.80	1080

Series : 10 Chromed Ball

Requires Lubrication

Order Code	Size	Static Load (kN)	Thread	×	Pitch	A	B	D	F	G	H	J	K	L	O	W	X	Ball dia Weight	
																		E	(g)
SFF.10.03	03	3.60	M3	×	0.5	10	3	12	21	27	4.5	5	6.5	3	5.18	6	5.5	7.93	7
SFF.10.04	04	4.50	M4	×	0.7	12	4	14	24	31	5.25	6.5	8.5	3.5	6.46	7	7	9.52	11
SFF.10.05	05	5.60	M5	×	0.8	14	5	16	27	35	6	7.5	9.5	4	7.71	8	8	11.11	14
SFF.10.06	06	6.90	M6	×	1	14	6	18	30	39	6.75	9.5	12	5	8.96	9	10	12.70	22
SFG.10.08	08	9.80	M8	×	1.25	17	8	22	36	47	9	12.5	16	5	10.40	12	13	15.88	38
SFG.10.10	10	13.20	M10	×	1.5	20	10	26	43	56	10.5	15	19	6.5	12.92	14	16	19.05	70
SFG.10.12	12	16.70	M12	×	1.75	22	12	30	50	65	12	17.5	22	6.5	15.43	16	18	22.23	120
SFG.10.14	14	20.60	M14	×	2	27	14	34	57	74	13.5	20	25	8	16.86	19	21	25.40	150
SFG.10.16	16	25.00	M16	×	2	33	16	38	64	83	15	22	27	8	19.39	21	24	28.58	200
SFG.10.18	18	29.40	M18	×	1.5	36	18	42	71	92	16.5	25	31	10	21.89	23	27	31.75	280
SFG.10.20	20	34.30	M20	×	1.5	40	20	46	77	100	18	27.5	34	10	24.38	25	30	34.92	370
SFG.10.22	22	41.20	M22	×	1.5	43	22	50	84	109	20	30	37	12	25.84	28	34	38.10	480
SFG.10.25	25	50.00	M24	×	2	48	25	56	94	122	22	33.5	42	12	29.60	31	36	42.85	670
SFG.10.30	30	66.70	M30	×	2	56	30	66	110	143	25	40	50	15	34.80	37	46	50.80	1080

Materials:

Housing: Sizes 2 - 12 - C22 or C35 Pb steel, zinc plated and passivated
 Sizes 14 - 30 - C35 steel, zinc plated and passivated

Ball: Standard - hardened ground, polished 100 Cr6 ball bearing steel
 Series 10 - hardened ground, hard chrome plated 100 Cr6 ball bearing steel

Inserts: Sizes 2 - 16 - Cu Zn 40 Mn Pb bronze
 Sizes 18 - 30 - Gc - Cu Su7 Zn Pb bronze

Unibal FEMALE ROD ENDS

For left-handed threads, please add the suffix "L" to the order code e.g., SFG.40.08.L.

The letter 'G' in the order code indicates that a lubrication nipple is fitted.

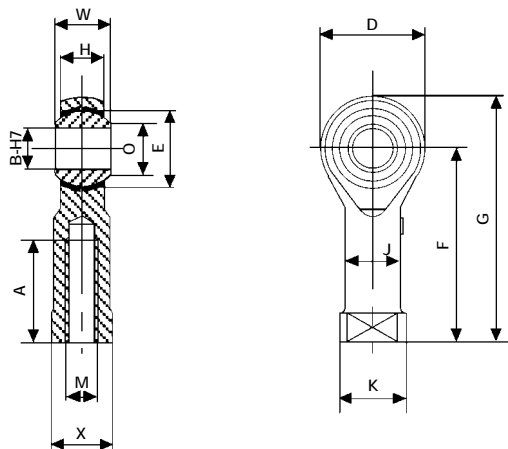

Series : 20 - As Standard - With Alternative Thread Pitch

Requires Lubrication

Order Code	Size	Static Load (kN)	Thread	×	Pitch	A	B	D	F	G	H	J	K	L	O	W	X	Ball dia E	Weight (g)
SFG.20.08	08	9.80	M8	×	1	17	8	22	36	47	9	12.5	16	5	10.40	12	13	15.88	38
SFG.20.10	10	13.20	M10	×	1	20	10	26	43	56	10.5	15	19	6.5	12.92	14	16	19.05	70
SFG.22.10	10	13.20	Cetop M10	×	1.25	20	10	26	43	56	10.5	15	19	6.5	12.92	14	16	19.05	70
SFG.22.12	12	16.70	Cetop M12	×	1.25	22	12	30	50	65	12	17.5	22	6.5	15.43	16	18	22.23	120
SFG.20.12	12	16.70	M12	×	1.5	22	12	30	50	65	12	17.5	22	6.5	15.43	16	18	22.23	120
SFG.20.14	14	20.60	M14	×	1.5	27	14	34	57	74	13.5	20	25	8	16.86	19	21	25.40	150
SFG.20.16	16	25.00	M16	×	1.5	33	16	38	64	83	15	22	27	8	19.39	21	24	28.58	200
SFG.20.18	18	29.40	M18	×	2.5	36	18	42	71	92	16.5	25	31	10	21.89	23	27	31.75	280
SFG.20.20	20	34.30	M20	×	2.5	40	20	46	77	100	18	27.5	34	10	24.38	25	30	34.92	370
SFG.20.22	22	41.20	M22	×	2.5	43	22	50	84	109	20	30	37	12	25.84	28	34	38.10	480
SFG.20.25	25	50.00	M24	×	3	48	25	56	94	122	22	33.5	42	12	29.60	31	36	42.85	670
SFG.20.30	30	66.70	M30	×	3.5	56	30	66	110	143	25	40	50	15	34.80	37	46	50.80	1080

Materials: As Standard series.

Series : 40 High Strength - Tight Bearing Fit

Requires Lubrication

Order Code	Size	Static Load (kN)	Thread	×	Pitch	A	B	D	F	G	H	J	K	L	O	W	X	Ball dia E	Weight (g)
SFF.40.05	05	11.20	M5	×	0.8	14	5	16	27	35	6	7.5	9.5	4	7.71	8	8	11.11	14
SFF.40.06	06	13.70	M6	×	1	14	6	18	30	39	6.75	9.5	12	5	8.96	9	10	12.70	22
SFG.40.08	08	19.60	M8	×	1.25	17	8	22	36	47	9	12.5	16	5	10.40	12	13	15.88	38
SFG.40.10	10	26.50	M10	×	1.5	20	10	26	43	56	10.5	15	19	6.5	12.92	14	16	19.05	70
SFG.40.12	12	33.30	M12	×	1.75	22	12	30	50	65	12	17.5	22	6.5	15.43	16	18	22.23	110
SFG.40.14	14	41.20	M14	×	2	27	14	34	57	74	13.5	20	25	8	16.86	19	21	25.40	150
SFG.40.16	16	50.00	M16	×	2	33	16	38	64	83	15	22	27	8	19.39	21	24	28.58	200
SFG.40.18	18	58.90	M18	×	1.5	36	18	42	71	92	16.5	25	31	10	21.89	23	27	31.75	280
SFG.40.20	20	68.70	M20	×	1.5	40	20	46	77	100	18	27.5	34	10	24.38	25	30	34.92	370
SFG.40.22	22	82.40	M22	×	1.5	43	22	50	84	109	20	30	37	12	25.84	28	34	38.10	480
SFG.40.25	25	100.10	M24	×	2	48	25	56	94	122	22	33.5	42	12	29.60	31	36	42.85	670
SFG.40.30	30	133.40	M30	×	2	56	30	66	110	143	25	40	50	15	34.80	37	46	50.80	1080

Materials:

Housing: C45 treated (or similar) steel, zinc plated and yellow passivated

Ball: Hardened ground, polished 100 Cr 6 ball bearing steel

Inserts: Gc-Cu Su7 Zn Pb bronze

Uniflon FEMALE ROD ENDS

Uniflon liners between the ball and race eliminate the need for lubrication.

For left-handed threads, please add the suffix "L" to the order code e.g., SFE.40.06.L.

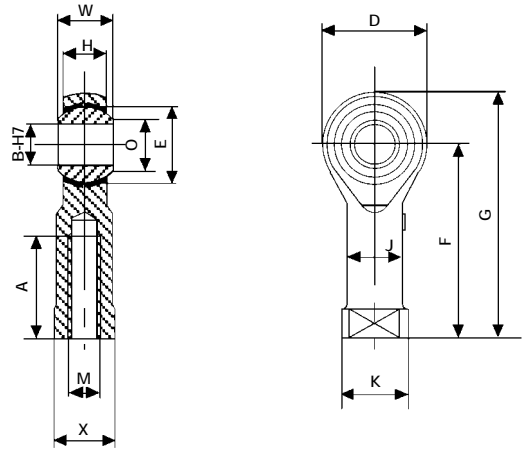

4

Series : Uniflon®E (Max Speed 6m/min)

Self-Lubricating

Order Code	Size	Static Load (kN)	Thread	×	Pitch	A	B	D	F	G	H	J	K	L	O	W	X	Ball dia Weight	
																		E	(g)
SFE.00.03	03	2.70	M3	×	0.5	10	3	12	21	27	4.5	5	6.5	3	5.18	6	5.5	7.93	7
SFE.00.04	04	3.50	M4	×	0.7	12	4	14	24	31	5.25	6.5	8.5	3.5	6.46	7	7	9.52	11
SFE.00.05	05	4.30	M5	×	0.8	14	5	16	27	35	6	7.5	9.5	4	7.71	8	8	11.11	14
SFE.00.06	06	5.30	M6	×	1	14	6	18	30	39	6.75	9.5	12	5	8.96	9	10	12.70	22
SFE.00.08	08	7.50	M8	×	1.25	17	8	22	36	47	9	12.5	16	5	10.40	12	13	15.88	38
SFE.00.10	10	10.10	M10	×	1.5	20	10	26	43	56	10.5	15	19	6.5	12.92	14	16	19.05	70
SFE.00.12	12	12.80	M12	×	1.75	22	12	30	50	65	12	17.5	22	6.5	15.43	16	18	22.23	110
SFE.00.14	14	15.80	M14	×	2	27	14	34	57	74	13.5	20	25	8	16.86	19	21	25.40	150
SFE.00.16	16	19.20	M16	×	2	33	16	38	64	83	15	22	27	8	19.39	21	24	28.58	200
SFE.00.18	18	22.60	M18	×	1.5	36	18	42	71	92	16.5	25	31	10	21.89	23	27	31.75	280
SFE.00.20	20	26.40	M20	×	1.5	40	20	46	77	100	18	27.5	34	10	24.38	25	30	34.92	370
SFE.00.22	22	31.70	M22	×	1.5	43	22	50	84	109	20	30	37	12	25.84	28	34	38.10	480
SFE.00.25	25	38.50	M24	×	2	48	25	56	94	122	22	33.5	42	12	29.60	31	36	42.85	670
SFE.00.30	30	51.30	M30	×	2	56	30	66	110	143	25	40	50	15	34.80	37	46	50.80	1080

Series : Uniflon VV (Max Speed 8m/min)

Self-Lubricating

Sizes and ratings as Uniflon®E Series

To specify VV series, change order code to SFV, eg SFV.00.08

Materials:

Housing: Sizes 3 - 12 - C35 Pb steel, zinc plated and passivated
 Sizes 14 - 30 - C35 steel, zinc plated and passivated

Ball: Hardened ground, polished 100 Cr6 ball bearing steel

Inserts: Sizes 3 - 12 - Cu Zu 40 Mn Pb bronze, Uniflon®E or Uniflon®VV
 Sizes 14 - 30 - Cu Zu 40 Pb 3 bronze, Uniflon®E or Uniflon®VV

Series : 40 Uniflon®E High Strength - Tight Bearing Fit

Self-Lubricating

Order Code	Size	Static Load (kN)	Thread	×	Pitch	A	B	D	F	G	H	J	K	L	O	W	X	Ball dia Weight	
																		E	(g)
SFE.40.05	05	7.80	M5	×	0.8	14	5	16	27	35	6	7.5	9.5	4	7.71	8	8	15.88	14
SFE.40.06	06	9.30	M6	×	1	14	6	18	30	39	6.75	9.5	12	5	8.96	9	10	19.05	22
SFE.40.08	08	10.30	M8	×	1.25	17	8	22	36	47	9	12.5	16	5	10.40	12	13	19.05	38
SFE.40.10	10	20.10	M10	×	1.5	20	10	26	43	56	10.5	15	19	6.5	12.92	14	16	22.23	70
SFE.40.12	12	25.60	M12	×	1.75	22	12	30	50	65	12	17.5	22	6.5	15.43	16	18	22.23	110
SFE.40.14	14	31.70	M14	×	2	27	14	34	57	74	13.5	20	25	8	16.86	19	21	25.40	150
SFE.40.16	16	38.50	M16	×	2	33	16	38	64	83	15	22	27	8	19.39	21	24	28.58	200
SFE.40.18	18	45.30	M18	×	1.5	36	18	42	71	92	16.5	25	31	10	21.89	23	27	31.75	280
SFE.40.20	20	52.80	M20	×	1.5	40	20	46	77	100	18	27.5	34	10	24.38	25	30	34.92	370
SFE.40.22	22	63.40	M22	×	1.5	43	22	50	84	109	20	30	37	12	25.84	28	34	38.10	480
SFE.40.25	25	77.00	M24	×	2	48	25	56	94	122	22	33.5	42	12	29.60	31	36	42.85	670
SFE.40.30	30	102.70	M30	×	2	56	30	66	110	143	25	40	50	15	34.80	37	46	50.80	1080

Materials:

Housing: C45 treated steel, zinc plated and yellow passivated

Ball: Hardened ground, polished 100 Cr6 ball bearing steel

Rack: C35 Pb steel, zinc plated and passivated Uniflon®E

Unibal FEMALE ROD ENDS

- Stainless steel series

For left-handed threads, please add the suffix "L" to the order code e.g., SFE.45.08.L.

The letter 'G' in the order code indicates that a lubrication nipple is fitted.

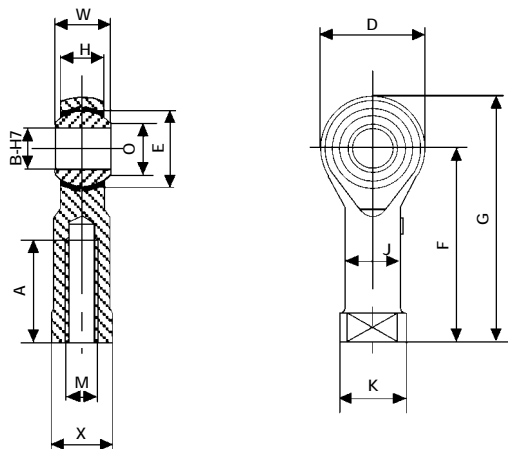

Series : 45 Stainless Steel, Standard

Requires Lubrication

Order Code	Size	Static Load (kN)	Thread × Pitch	A	B	D	F	G	H	J	K	L	O	W	X	Ball dia Weight	
																E	(g)
SFF.45.03	03	2.2	M3 × 0.5	10	3	12	21	27	4.5	5	6.5	3	5.18	6	5.5	7.93	7
SFF.45.04	04	2.7	M4 × 0.7	12	4	14	24	31	5.25	6.5	8.5	3.5	6.46	7	7	9.52	11
SFF.45.05	05	3.3	M5 × 0.8	14	5	16	27	35	6	7.5	9.5	4	7.71	8	8	11.11	14
SFF.45.06	06	4.0	M6 × 1	14	6	18	30	39	6.75	9.5	12	5	8.96	9	10	12.70	22
SFG.45.08	08	5.9	M8 × 1.25	17	8	22	36	47	9	12.5	16	5	10.40	12	13	15.88	38
SFG.45.10	10	7.8	M10 × 1.5	20	10	26	43	56	10.5	15	19	6.5	12.92	14	16	19.05	70
SFG.45.12	12	10.0	M12 × 1.75	22	12	30	50	65	12	17.5	22	6.5	15.43	16	18	22.23	110
SFG.45.14	14	12.3	M14 × 2	27	14	34	57	74	13.5	20	25	8	16.86	19	21	25.40	150
SFG.45.16	16	14.9	M16 × 2	33	16	38	64	83	15	22	27	8	19.39	21	24	28.58	200
SFG.45.18	18	17.8	M18 × 1.5	36	18	42	71	92	16.5	25	31	10	21.89	23	27	31.75	280
SFG.45.20	20	20.9	M20 × 1.5	40	20	46	77	100	18	27.5	34	10	24.38	25	30	34.92	370
SFG.45.22	22	24.6	M22 × 1.5	43	22	50	84	109	20	30	37	12	25.84	28	34	38.10	480
SFG.45.25	25	30.0	M24 × 2	48	25	56	94	122	22	33.5	42	12	29.60	31	36	42.85	670
SFG.45.30	30	39.7	M30 × 2	56	30	66	110	143	25	40	50	15	34.80	37	46	50.80	1080

Series : 45 Uniflon®E Stainless Steel

Self-Lubricating

Order Code	Size	Static Load (kN)	Thread × Pitch	A	B	D	F	G	H	J	K	L	O	W	X	Ball dia Weight	
																E	(g)
SFE.45.03	03	1.6	M3 × 0.5	10	3	12	21	27	4.5	5	6.5	3	5.18	6	5.5	7.93	7
SFE.45.04	04	2.0	M4 × 0.7	12	4	14	24	31	5.25	6.5	8.5	3.5	6.46	7	7	9.52	11
SFE.45.05	05	2.5	M5 × 1	14	5	16	27	35	6	7.5	9.5	4	7.71	8	8	11.11	14
SFE.45.06	06	3.0	M6 × 1.25	14	6	18	30	39	6.75	9.5	12	5	8.96	9	10	12.70	22
SFE.45.08	08	4.5	M8 × 1.5	17	8	22	36	47	9	12.5	16	5	10.40	12	13	15.88	38
SFE.45.10	10	6.0	M10 × 1.75	20	10	26	43	56	10.5	15	19	6.5	12.92	14	16	19.05	70
SFE.45.12	12	7.7	M12 × 2	22	12	30	50	65	12	17.5	22	6.5	15.43	16	18	22.23	110
SFE.45.14	14	9.4	M14 × 2	27	14	34	57	74	13.5	20	25	8	16.86	19	21	25.40	150
SFE.45.16	16	11.4	M16 × 1.5	33	16	38	64	83	15	22	27	8	19.39	21	24	28.58	200
SFE.45.18	18	13.7	M18 × 1.5	36	18	42	71	92	16.5	25	31	10	21.89	23	27	31.75	280
SFE.45.20	20	16.0	M20 × 1.5	40	20	46	77	100	18	27.5	34	10	24.38	25	30	34.92	370
SFE.45.22	22	18.9	M22 × 2	43	22	50	84	109	20	30	37	12	25.84	28	34	38.10	480
SFE.45.25	25	23.1	M24 × 2	48	25	56	94	122	22	33.5	42	12	29.60	31	36	42.85	670
SFE.45.30	30	30.5	M30 × 2	56	30	66	110	143	25	40	50	15	34.80	37	46	50.80	1080

Materials:

Housing: Stainless steel x 10 Cr Ni S 189 (A151 303)

Ball: Stainless steel x 46 Cr 13 (A141 420)

Inserts: Standard type : Gc Cu Sn 7 Zn Pb bronze

Race: Self-lubricating type : x 10 Cr Ni S 189 (A151 303) Uniflon®E

Note:

The spherical size is part of the specification (i.e. SSF.00.12 = size 12, SSF.10.16 = size 16).
 The size corresponds with the bore Ø (B - H7)
 The tables below give the maximum allowable radial and axial loads in kN.

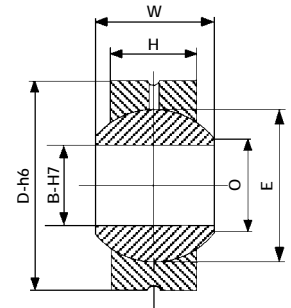

4

Series : Standard				Bearing Surface : Steel/Bronze						Requires Lubrication	
Order Code	Size	Static Loads		B	D	H	O	W	Ball Dia E	Weight (g)	
		Radial (kN)	Axial (kN)								
SSF.00.02	02	2.4	0.5	2	9	3.6	3.60	4.8	6.00	3	
SSF.00.03	03	4.2	1	3	12	4.5	5.18	6	7.93	4	
SSF.00.04	04	5.9	1.4	4	14	5.25	6.46	7	9.52	6	
SSF.00.05	05	7.8	1.9	5	16	6	7.71	8	11.11	9	
SSF.00.06	06	9.8	2.4	6	18	6.75	8.96	9	12.70	12	
SSF.00.08	08	16.7	4	8	22	9	10.40	12	15.88	24	
SSF.00.10	10	25.3	5.7	10	26	10.5	12.92	14	19.05	38	
SSF.00.12	12	31.4	7.5	12	30	12	15.43	16	22.23	57	
SSF.00.14	14	40.2	9.7	14	34	13.5	16.86	19	25.40	83	
SSF.00.16	16	50	12.2	16	38	15	19.39	21	28.58	110	
SSF.00.18	18	61.8	14.8	18	42	16.5	21.89	23	31.75	150	
SSF.00.20	20	73.6	17.8	20	46	18	24.38	25	34.92	200	
SSF.00.22	22	88.3	21.6	22	50	20	25.84	28	38.10	250	
SSF.00.25	25	110.8	26.7	25	56	22	29.60	31	42.85	360	
SSF.00.30	30	147.1	35.9	30	66	25	34.80	37	50.80	570	

Series : 10 Chromed Ball				Bearing Surface : Steel/Bronze						Requires Lubrication	
Order Code	Size	Static Loads		B	D	H	O	W	Ball Dia E	Weight (g)	
		Radial (kN)	Axial (kN)								
SSF.10.02	02	2.4	0.5	2	9	3.6	3.60	4.8	6.00	3	
SSF.10.03	03	4.2	1	3	12	4.5	5.18	6	7.93	4	
SSF.10.04	04	5.9	1.4	4	14	5.25	6.46	7	9.52	6	
SSF.10.05	05	7.8	1.9	5	16	6	7.71	8	11.11	9	
SSF.10.06	06	9.8	2.4	6	18	6.75	8.96	9	12.70	12	
SSF.10.08	08	16.7	4	8	22	9	10.40	12	15.88	24	
SSF.10.10	10	25.3	5.7	10	26	10.5	12.92	14	19.05	38	
SSF.10.12	12	31.4	7.5	12	30	12	15.43	16	22.23	57	
SSF.10.14	14	40.2	9.7	14	34	13.5	16.86	19	25.40	83	
SSF.10.16	16	50	12.2	16	38	15	19.39	21	28.58	110	
SSF.10.18	18	61.8	14.8	18	42	16.5	21.89	23	31.75	150	
SSF.10.20	20	73.6	17.8	20	46	18	24.38	25	34.92	200	
SSF.10.22	22	88.3	21.6	22	50	20	25.84	28	38.10	250	
SSF.10.25	25	110.8	26.7	25	56	22	29.60	31	42.85	360	
SSF.10.30	30	147.1	35.9	30	66	25	34.80	37	50.80	570	

Materials:

Housing: Sizes 2 - 16 - C35 steel, zinc plated and passivated
 Sizes 18 - 30 - 100 Cr6 ball bearing steel, carbonised

Ball: Standard - hardened ground, polished 100 Cr6 ball bearing steel
 Series 10 - hardened ground, polished, hard chrome plated 100 Cr6 ball bearing steel

Inserts: Sizes 2 - 16 - Cu Zn 40 Mn Pb bronze
 Sizes 18 - 30 - Gc - Cu Sn7 Zn Pb bronze

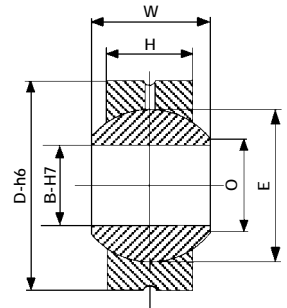

Series : Heavy Duty **Bearing Surface : Steel/Steel** **Requires Generous Lubrication**

Order Code	Size	Static Loads		B	D	H	O	W	Ball Dia	Weight
		Radial (kN)	Axial (kN)						E	(g)
SSA.00.02	02	6	1.3	2	9	3.6	3.60	4.8	6	3
SSA.00.03	03	10.3	2.4	3	12	4.5	5.18	6	7.93	4
SSA.00.04	04	14.7	3.4	4	14	5.25	6.46	7	9.52	6
SSA.00.05	05	19.6	4.6	5	16	6	7.71	8	11.11	9
SSA.00.06	06	25.5	6.1	6	18	6.75	8.96	9	12.70	12
SSA.00.08	08	41.2	10	8	22	9	10.40	12	15.88	24
SSA.00.10	10	58.9	14.2	10	26	10.5	12.92	14	19.05	38
SSA.00.12	12	78.5	18.8	12	30	12	15.43	16	22.23	57
SSA.00.14	14	98.1	24.2	14	34	13.5	16.86	19	25.40	83
SSA.00.16	16	122.6	30.4	16	38	15	19.39	21	28.58	110
SSA.00.18	18	153	37	18	42	16.5	21.89	23	31.75	150
SSA.00.20	20	183.4	44.6	20	46	18	24.38	25	34.92	200
SSA.00.22	22	220.7	54	22	50	20	25.84	28	38.10	250
SSA.00.25	25	274.7	66.7	25	56	22	29.60	31	42.85	360
SSA.00.30	30	363	89.8	30	66	25	34.80	37	50.80	570
SSA.00.35	35	510.1	125.1	35	80	30	41.44	42	59	1020
SSA.00.40	40	657.3	159.4	40	90	34	47.75	47	67	1440
SSA.00.45	45	833.8	201.1	45	100	38	54.99	51	75	1940
SSA.00.50	50	981	245.2	50	110	42	61.26	56	83	2630

Series : 10 Heavy Duty Chromed Ball **Bearing Surface : Steel/Steel** **Requires Generous Lubrication**

Order Code	Size	Static Loads		B	D	H	O	W	Ball Dia	Weight
		Radial (kN)	Axial (kN)						E	(g)
SSA.10.02	02	6	1.3	2	9	3.6	3.60	4.8	6	3
SSA.10.03	03	10.3	2.4	3	12	4.5	5.18	6	7.93	4
SSA.10.04	04	14.7	3.4	4	14	5.25	6.46	7	9.52	6
SSA.10.05	05	19.6	4.6	5	16	6	7.71	8	11.11	9
SSA.10.06	06	25.5	6.1	6	18	6.75	8.96	9	12.70	12
SSA.10.08	08	41.2	10	8	22	9	10.40	12	15.88	24
SSA.10.10	10	58.9	14.2	10	26	10.5	12.92	14	19.05	38
SSA.10.12	12	78.5	18.8	12	30	12	15.43	16	22.23	57
SSA.10.14	14	98.1	24.2	14	34	13.5	16.86	19	25.40	83
SSA.10.16	16	122.6	30.4	16	38	15	19.39	21	28.58	110
SSA.10.18	18	153	37	18	42	16.5	21.89	23	31.75	150
SSA.10.20	20	183.4	44.6	20	46	18	24.38	25	34.92	200
SSA.10.22	22	220.7	54	22	50	20	25.84	28	38.10	250
SSA.10.25	25	274.7	66.7	25	56	22	29.60	31	42.85	360
SSA.10.30	30	363	89.8	30	66	25	34.80	37	50.80	570
SSA.10.35	35	510.1	125.1	35	80	30	41.44	42	59	1020
SSA.10.40	40	657.3	159.4	40	90	34	47.75	47	67	1440
SSA.10.45	45	833.8	201.1	45	100	38	54.99	51	75	1940
SSA.10.50	50	981	245.2	50	110	42	61.26	56	83	2630

Materials:

Housing: Sizes 2 - 16 - C35 Pb steel, zinc and clear passivated
 Sizes 18 - 50 - Ck35 steel, zinc and clear passivated

Ball: SSA.00 - hardened ground, polished 100 Cr6 ball bearing steel
 SSA.10 - hardened ground, polished hard chrome plated 100 Cr6 ball bearing steel

- Stainless steel

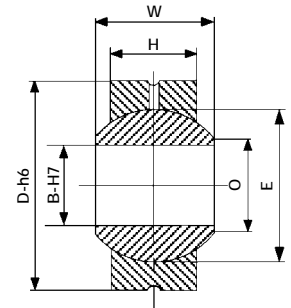

4

Series : Stainless Steel				Bearing Surface : Steel/Bronze					Requires Lubrication	
Order Code	Size	Static Loads		B	D	H	O	W	Ball Dia E	Weight (g)
		Radial (kN)	Axial (kN)							
SSF.45.03	03	4.2	1	3	12	4.5	5.18	6	7.93	4
SSF.45.05	05	7.8	1.9	5	16	6	7.71	8	11.11	9
SSF.45.06	06	9.8	2.4	6	18	6.75	8.96	9	12.70	12
SSF.45.08	08	16.7	4	8	22	9	10.40	12	15.88	24
SSF.45.10	10	25.3	5.7	10	26	10.5	12.92	14	19.05	38
SSF.45.12	12	31.4	7.5	12	30	12	15.43	16	22.23	57
SSF.45.14	14	40.2	9.7	14	34	13.5	16.86	19	25.40	83
SSF.45.16	16	50	12.2	16	38	15	19.39	21	28.58	110
SSF.45.18	18	61.8	14.8	18	42	16.5	21.89	23	31.75	150
SSF.45.20	20	73.6	17.8	20	46	18	24.38	25	34.92	200
SSF.45.22	22	88.3	21.6	22	50	20	25.84	28	38.10	250
SSF.45.25	25	110.8	26.7	25	56	22	29.60	31	42.85	360
SSF.45.30	30	147.1	35.9	30	66	25	34.80	37	50.80	570

Series : 45 Stainless Steel				Bearing Surface : St.Steel/St.Steel					Requires Generous Lubrication	
Order Code	Size	Static Loads		B	D	H	O	W	Ball Dia E	Weight (g)
		Radial (kN)	Axial (kN)							
SSA.45.03	03	6.1	1.7	3	12	4.5	5.18	6	7.93	4
SSA.45.05	05	10.8	2.3	5	16	6	7.71	8	11.11	9
SSA.45.06	06	13.7	4.1	6	18	6.75	8.96	9	12.70	12
SSA.45.08	08	23.5	6.8	8	22	9	10.40	12	15.88	24
SSA.45.10	10	34.3	9.6	10	26	10.5	12.92	14	19.05	38
SSA.45.12	12	45.1	12.7	12	30	12	15.43	16	22.23	57
SSA.45.14	14	57.9	16.5	14	34	13.5	16.86	19	25.40	83
SSA.45.16	16	72.6	20.6	16	38	15	19.39	21	28.58	110
SSA.45.18	18	89.3	25	18	42	16.5	21.89	23	31.75	150
SSA.45.20	20	106.9	30.3	20	46	18	24.38	25	34.92	200
SSA.45.22	22	128.5	36.7	22	50	20	25.84	28	38.10	250
SSA.45.25	25	160.9	45.3	25	56	22	29.60	31	42.85	360
SSA.45.30	30	213.9	61	30	66	25	34.80	37	50.80	570

Materials:

Housing: Stainless steel x 10 Cr Ni S 189 (A151 303)

Ball: Hardened ground polished stainless steel x 46 Cr 13 (A141 420)

Inserts: SSF.45 : Gc Cu Sn 7 Zn Pb bronze

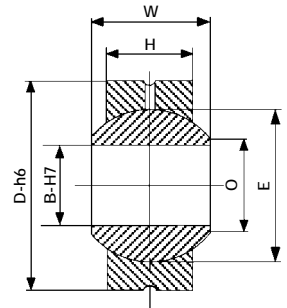

Series : Uniflon [®] E		Bearing Surface : Steel/Uniflon							Self-Lubricating	
Order Code	Size	Static Loads		B	D	H	O	W	Ball Dia E	Weight (g)
		Radial (kN)	Axial (kN)							
SSE.00.03	03	10.3	2.5	3	12	4.5	5.18	6	7.93	4
SSE.00.04	04	14.7	3.5	4	14	5.25	6.46	7	9.52	6
SSE.00.05	05	19.6	4.4	5	16	6	7.71	8	11.11	9
SSE.00.06	06	22.5	5	6	18	6.75	8.96	9	12.70	12
SSE.00.08	08	41.2	6.2	8	22	9	10.40	12	15.88	24
SSE.00.10	10	58.9	7.5	10	26	10.5	12.92	14	19.05	38
SSE.00.12	12	78.5	8.8	12	30	12	15.43	16	22.23	57
SSE.00.14	14	98.1	10	14	34	13.5	16.86	19	25.40	83
SSE.00.16	16	122.6	11.3	16	38	15	19.39	21	28.58	110
SSE.00.18	18	153	12.5	18	42	16.5	21.89	23	31.75	150
SSE.00.20	20	183.4	13.8	20	46	18	24.38	25	34.92	200
SSE.00.22	22	220.7	15	22	50	20	25.84	28	38.10	250
SSE.00.25	25	274.7	16.9	25	56	22	29.60	31	42.85	360
SSE.00.30	30	363	20.1	30	66	25	34.80	37	50.80	570

Materials:

Housing: Sizes 3 - 16 - C35 Pb steel, zinc plated and clear passivated
 Sizes 18 - 30 - Ck35 steel, zinc plated and clear passivated

Ball: Hardened ground, polished 100 Cr6 ball bearing steel

Series : High Strength		Bearing Surface : Steel/Uniflon [®] E							Self-Lubricating	
Order Code	Size	Static Loads		B	D	H	O	W	Ball Dia E	Weight (g)
		Radial (kN)	Axial (kN)							
SSE.50.05	05	29.4	4.4	5	16	6	7.71	8	11.11	9
SSE.50.06	06	36.3	5	6	18	6.75	8.96	9	12.70	12
SSE.50.08	08	58.9	6.2	8	22	9	10.40	12	15.88	24
SSE.50.10	10	88.3	7.5	10	26	10.5	12.92	14	19.05	38
SSE.50.12	12	117.7	8.8	12	30	12	15.43	16	22.23	57
SSE.50.14	14	147.1	10	14	34	13.5	16.86	19	25.40	83
SSE.50.16	16	176.6	11.3	16	38	15	19.39	21	28.58	110
SSE.50.18	18	225.6	12.5	18	42	16.5	21.89	23	31.75	150
SSE.50.20	20	274.7	13.8	20	46	18	24.38	25	34.92	200
SSE.50.22	22	323.7	15	22	50	20	25.84	28	38.10	250

Materials:

Housing: High tensile steel, similar to 45 S 20, zinc plated and yellow passivated

Ball: Hardened ground, polished hard chrome plated 100 Cr6 ball bearing steel Uniflon[®]E

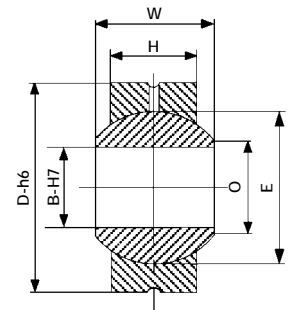

4

Series : Uniflon [®] VV		Bearing Surface : Steel/Uniflon [®]							Self-Lubricating	
Order Code	Size	Static Loads		B	D	H	O	W	Ball Dia E	Weight (g)
		Radial (kN)	Axial (kN)							
SSV.00.02	02	5.1	1.8	2	9	3.6	3.60	4.8	6	3
SSV.00.03	03	7.3	2.5	3	12	4.5	5.18	6	7.93	4
SSV.00.04	04	11.0	3.5	4	14	5.25	6.46	7	9.52	6
SSV.00.05	05	14.7	4.4	5	16	6	7.71	8	11.11	9
SSV.00.06	06	18.6	5.0	6	18	6.75	8.96	9	12.70	12
SSV.00.08	08	31.4	6.2	8	22	9	10.40	12	15.88	24
SSV.00.10	10	44.1	7.5	10	26	10.5	12.92	14	19.05	38
SSV.00.12	12	58.9	8.8	12	30	12	15.43	16	22.23	57
SSV.00.14	14	74.5	10.0	14	34	13.5	16.86	19	25.40	83
SSV.00.16	16	92.2	11.3	16	38	15	19.39	21	28.58	110
SSV.00.18	18	114.8	12.5	18	42	16.5	21.89	23	31.75	150
SSV.00.20	20	137.3	13.8	20	46	18	24.38	25	34.92	200
SSV.00.22	22	166.8	15.0	22	50	20	25.84	28	38.10	250
SSV.00.25	25	206.0	16.9	25	56	22	29.60	31	42.85	360
SSV.00.30	30	274.7	20.1	30	66	25	34.80	37	50.80	570

Materials:

Housing: Sizes 2 - 16 - C35 Pb steel, zinc plated and clear passivated
 Sizes 18 - 30 - Ck35 steel, zinc plated and clear passivated

Ball: Hardened ground, polished 100 Cr6 ball bearing steel Uniflon[®]VV

Series : 45 Uniflon [®] E Stainless Steel		Bearing Surface : St.Steel/Uniflon [®]							Self-Lubricating	
Order Code	Size	Static Loads		B	D	H	O	W	Ball Dia E	Weight (g)
		Radial (kN)	Axial (kN)							
SSE.45.03	03	7.9	2.5	3	12	4.5	5.18	6	7.93	4
SSE.45.04	04	11.3	3.5	4	14	5.25	6.46	7	9.52	6
SSE.45.05	05	15	4.4	5	16	6	7.71	8	11.11	9
SSE.45.06	06	19.6	5	6	18	6.75	8.96	9	12.70	12
SSE.45.08	08	31.7	6.2	8	22	9	10.40	12	15.88	24
SSE.45.10	10	45.3	7.5	10	26	10.5	12.92	14	19.05	38
SSE.45.12	12	60.4	8.8	12	30	12	15.43	16	22.23	57
SSE.45.14	14	75.5	10	14	34	13.5	16.86	19	25.40	83
SSE.45.16	16	94.4	11.3	16	38	15	19.39	21	28.58	110
SSE.45.18	18	117.8	12.5	18	42	16.5	21.89	23	31.75	150
SSE.45.20	20	141.2	13.8	20	46	18	24.38	25	34.92	200
SSE.45.22	22	169.9	15	22	50	20	25.84	28	38.10	250
SSE.45.25	25	211.5	16.9	25	56	22	29.60	31	42.85	360
SSE.45.30	30	279.5	20.1	30	66	25	34.80	37	50.80	570

Materials:

Housing: Stainless steel x 10 Cr Ni S 189 (A151 303)

Ball: Hardened ground, polished stainless steel x 46 Cr13 (A151 420) Uniflon[®]E

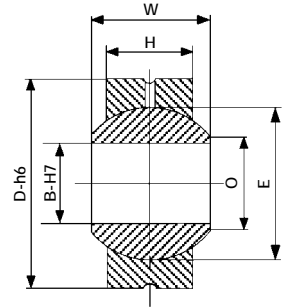

Series : 50 High Performance

Bearing Surface : Steel/Steel

Requires Generous Lubrication

Order Code	Size	Static Loads		B	D	H	O	W	Ball Dia	Weight
		Radial (kN)	Axial (kN)						E	(g)
SSA.50.03	03	14.7	3.6	3	12	4.5	5.18	6	7.93	4
SSA.50.05	05	29.4	6.9	5	16	6	7.71	8	11.11	9
SSA.50.06	06	36.3	8.8	6	18	6.75	8.96	9	12.70	12
SSA.50.08	08	58.9	14.7	8	22	9	10.40	12	15.88	24
SSA.50.10	10	88.3	20.6	10	26	10.5	12.92	14	19.05	38
SSA.50.12	12	117.7	27.5	12	30	12	15.43	16	22.23	57
SSA.50.14	14	147.1	36.3	14	34	13.5	16.86	19	25.40	83
SSA.50.16	16	176.6	45.1	16	38	15	19.39	21	28.58	110
SSA.50.18	18	225.6	54.9	18	42	16.5	21.89	23	31.75	150
SSA.50.20	20	274.7	66.7	20	46	18	24.38	25	34.92	200
SSA.50.22	22	323.7	80.4	22	50	20	25.84	28	38.10	250

Materials:

Housing: High tensile steel, similar to 45 S20, zinc plated and yellow passivated

Ball: Hardened ground, polished, hard chrome plated 100 Cr6 ball bearing steel

Great care should be taken when mounting and installing Unibal rod ends and spherical bearings, to ensure that they operate under optimum conditions.

Incorrect mounting will considerably reduce the life of the product. The examples of installation shown here illustrate some suitable mounting methods.

4

Fig 1. Classic mounting of rod end housings: fastened together by means of a threaded rod to span two supports, secured with a locknut. As a general rule, the ball is held in place by shouldered supports, sleeves, or by means of a set screw + washer as the illustration shows.

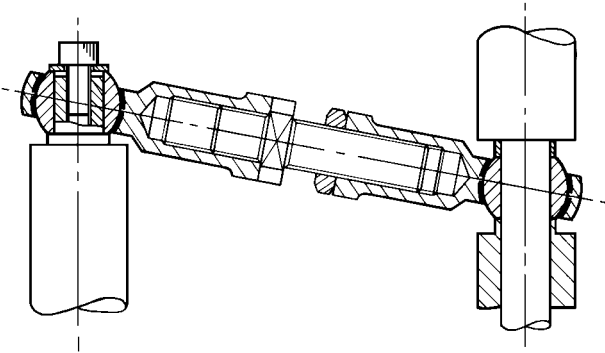

Fig 2. The ball is held in a clamping fork, with a shouldered screw passing through the two lateral spacers, allowing a maximum misalignment angle.

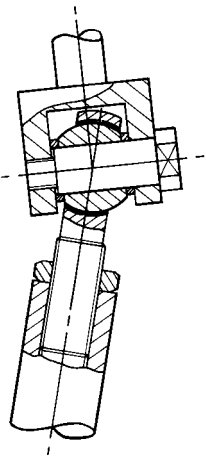

Fig 3. The spherical bearings are pressed into bores machined to the correct size. One of the balls is held by material set: swaging of the shaft end. Driving the ball on to the shaft is not good practice; the sliding moment will increase and the ball may even become locked into the housing.

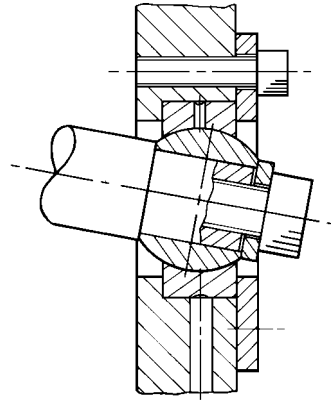
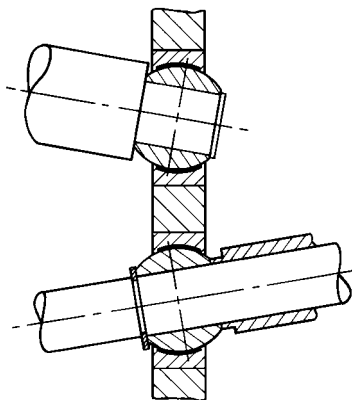

Fig 4. This method of installation ensures that the housing is not subjected to stress. It is particularly appropriate to applications involving high ball speeds as the sliding moment is unaffected during installation. This rigid construction is suitable for high axial and radial loads.

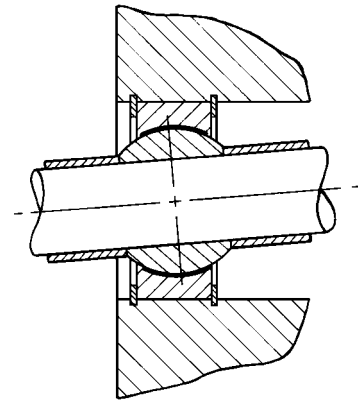

Fig 5. A simple installation can be achieved using internal circlips. However, this installation method is not suitable for applications involving high axial loads.

lubrication & maintenance

- Components with steel/steel or steel/bronze bearing surfaces require regular lubrication for optimum life expectancy.
- Components with steel/UNIFLON bearing surfaces do not require any lubrication or maintenance.

standard lubricant

Mobiplex 47 lubricant (ISO 3498 × M2) is applied to all Unibal products which require regular lubrication. It is available all over the world and is ideal for the purpose:

- Base: calcium compound
- Drop point: 260°C
- Working temperature: -25°C to 125°C
- Excellent wear properties
- Resists shearing

special lubricants

Available on request for enhanced performance in especially demanding applications. Eg. very high loads/speeds or infrequent operation.

self lubricating bearings

Rod ends and spherical bearings with UNIFLON liners are designed to operate without lubrication; no lubricant is applied during assembly. However, lubrication will reduce the sliding moment and enhance life expectancy, but it may also modify the operating characteristic of the bearing.

Please contact us for assistance or advice regarding lubrication.

ECONOMY ROD ENDS

- Self-lubricating
- Maintenance free
- Wear resistant bearing surfaces
- Low constant rotational resistance
- Conformity with DIN 648 series K
- Operating temperature range
-30°C to +150°C

materials

Bearing surfaces : steel on bronze

Ball : bearing steel 100 Cr 6, hardened,
ground and polished

Inserts : special bronze cold formed on to
the ball

Housing : sizes 5-12 - low carbon steel
: sizes 16-35 - high carbon alloy steel



4

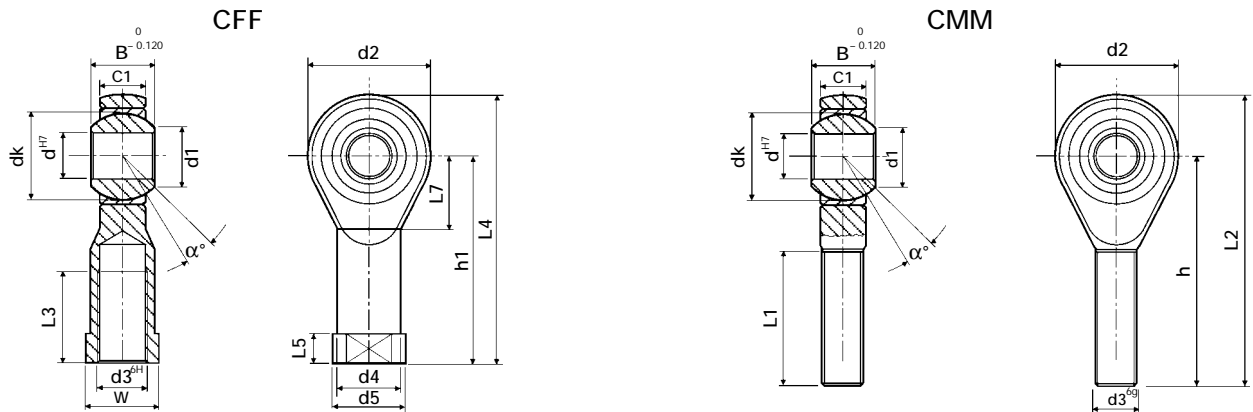

Series : Standard

Order Code ^①	d	d3	B	C1	d1	d2	d4	d5	dk	h1	L3	L4	L5	L7	W	static load α° movement		weight
																Fs (daN)	angle	
CFF.00.05	5	M5	8	6.00	7.7	18	9.0	11	11.112	27	10	36	4.0	10	9	600	13	0.019
CFF.00.06	6	M6	9	6.75	8.9	20	10.0	13	12.700	30	12	40	5.0	11	11	700	13	0.026
CFF.00.08	8	M8	12	9.00	10.4	24	12.5	16	15.875	36	16	48	5.0	13	14	1200	14	0.046
CFF.00.10	10	M10	14	10.50	12.9	28	15.0	19	19.050	43	20	57	6.5	15	17	1400	13	0.076
CFF.00.12	12	M12	16	12.00	15.4	32	17.5	22	22.225	50	22	66	6.5	17	19	1900	13	0.110
CFF.00.16	16	M16	21	15.00	19.3	42	22.0	27	28.575	64	28	85	8.0	23	22	4800	15	0.220
CFF.00.30	30	M30 x 2	37	25.00	34.8	70	40.0	50	50.800	110	51	145	15.0	36	41	10800	17	1.140
CFF.00.35	35	M36 x 2	43	28.00	37.7	80	46.0	58	57.150	125	56	165	17.0	41	50	12400	19	1.600

① For left-handed thread add L (example CFF.00.05L)

Series : Cetop

Conformity with ISO/CETOP RP 103 P/DIN 24335 - for use with pneumatic cylinders

Order Code ^①	d	d3	B	C1	d1	d2	d4	d5	dk	h1	L3	L4	L5	L7	W	static load α° movement		weight
																Fs (daN)	angle	
CFF.00.05.C	5	M4	8	6.00	7.7	18	9.0	11	11.112	27	10	36	4.0	10	9	600	13	0.018
CFF.00.10.C	10	M10 x 1.25	14	10.50	12.9	28	15.0	19	19.050	43	20	57	6.5	15	17	1400	13	0.076
CFF.00.12.C	12	M12 x 1.25	16	12.00	15.4	32	17.5	22	22.225	50	22	66	6.5	17	19	1900	13	0.110
CFF.00.16.C	16	M16 x 1.5	21	15.00	19.3	42	22.0	27	28.575	64	28	85	8.0	23	22	1800	15	0.220
CFF.00.20.C	20	M20 x 1.5	25	18.00	24.3	50	27.5	34	34.925	77	33	102	10.0	27	30	5200	14	0.409
CFF.00.30.C	30	M27 x 2	37	25.00	34.8	70	40.0	50	50.800	110	51	145	15.0	36	41	10800	17	1.200

① For left-handed thread add L (example CFF.00.05.CL)

Order Code ^①	d	d3	B	C1	d1	d2	dk	h	L1	L2	static load α° movement		weight
											Fs (daN)	angle	
CMM.00.05	5	M5	8	6.00	7.7	18	11.112	33	19	42	300	13	0.015
CMM.00.06	6	M6	9	6.75	8.9	20	12.700	36	21	46	400	13	0.022
CMM.00.08	8	M8	12	9.00	10.4	24	15.875	42	25	54	800	14	0.038
CMM.00.10	10	M10	14	10.50	12.9	28	19.050	48	28	62	1300	13	0.063
CMM.00.12	12	M12	16	12.00	15.4	32	22.225	54	32	70	1700	13	0.100
CMM.00.16	16	M16	21	15.00	19.3	42	28.575	66	37	84	4800	15	0.195
CMM.00.20	20	M20 x 1.5	25	18.00	24.3	50	34.925	78	45	103	5200	14	0.370

① For left-handed thread add L (example CMM.00.05L)

ECONOMY SPHERICAL BEARINGS

- Maintenance free
- High load capacity
- Wear resistant
- Low constant rotational resistance
- Stick slip free
- Operating temperature range
-30°C to +150°C

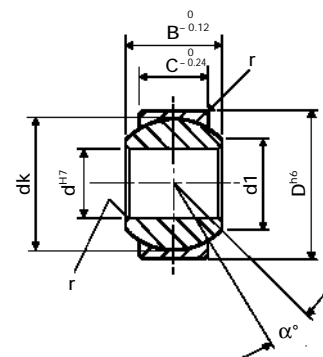

A unique steel on steel self-lubricating bearing conforming with DIN 648 series K.

4

Order Code	d	B	C	D	d1	dk	r	static load Co (daN)	α° tilting angle	weight (kg)
CSS.00.05	5	8	6.00	13	7.7	11.112	0.3	1300	13	0.006
CSS.00.06	6	9	6.75	16	8.9	12.700	0.3	1700	13	0.009
CSS.00.08	8	12	9.00	19	10.4	15.875	0.3	2800	14	0.016
CSS.00.10	10	14	10.50	22	12.9	19.050	0.3	4000	13	0.025
CSS.00.12	12	16	12.00	26	15.4	22.225	0.3	5300	13	0.040
CSS.00.16	16	21	15.00	32	19.3	28.575	0.3	8500	15	0.080
CSS.00.20	20	25	18.00	40	24.3	34.925	0.3	12500	14	0.150
CSS.00.30	30	37	25.00	55	34.8	50.800	0.6	25400	17	0.380
CSS.00.35	35	43	28.00	62	37.7	57.150	0.6	32000	19	0.490

materials

Ball : bearing steel 100 Cr 6, hardened, ground and polished.

External ring : special steel, self-lubricating, cold formed on to the ball.

BALL & SOCKET JOINTS

Manufactured to DIN 71802, these ball & socket joints feature induction hardened balls to resist wear. Security clips retain the threaded ball studs in their sockets and spanner flats are provided on the stud. Spanner flats can be provided on the sockets to order. Available in mild steel - zinc plated and clear passivated or in stainless steel, from stock.

Maximum static push/pull values are valid for both radial and axial loads but do not apply to stainless steel versions.

Supplied with appropriate lock nut.



4

Order Code	Material	Thread	Size	Ball Ø d1	Thread d2	D4	L1	L2	L3	L4	L5	L6	R	Spanner flats A/F	Max static push/pull (kp)
373.05.C	Mild Steel	RH	5	8	M5	8	28.5	22	10.5	25.0	10.2	9	6.4	7	30
373.06.C	Mild Steel	RH	6	10	M6	10	32.5	25	11.5	30.0	12.5	11	7.5	8	70
373.08.C	Mild Steel	RH	8	13	M8	13	39.5	30	14.0	38.0	16.5	13	9.7	11	150
373.10.C	Mild Steel	RH	10	16	M10	16	47.0	35	15.5	47.5	20.0	16	12.0	13	200
373.12.C	Mild Steel	RH	12	16	M12	16	47.0	35	15.5	47.5	20.0	16	12.0	13	200
374.05.C	Mild Steel	LH	5	8	M5	8	28.5	22	10.5	25.0	10.2	9	6.4	7	30
374.06.C	Mild Steel	LH	6	10	M6	10	32.5	25	11.5	30.0	12.5	11	7.5	8	70
374.08.C	Mild Steel	LH	8	13	M8	13	39.5	30	14.0	38.0	16.5	13	9.7	11	150
374.10.C	Mild Steel	LH	10	16	M10	16	47.0	35	15.5	47.5	20.0	16	12.0	13	200
374.12.C	Mild Steel	LH	12	16	M12	16	47.0	35	15.5	47.5	20.0	16	12.0	13	200
373.05.C.S	Stainless Steel	RH	5	8	M5	8	28.5	22	10.5	25.0	10.2	9	6.4	-	-
373.06.C.S	Stainless Steel	RH	6	10	M6	10	32.5	25	11.5	30.0	12.5	11	7.5	-	-
373.08.C.S	Stainless Steel	RH	8	13	M8	13	39.5	30	14.0	38.0	16.5	13	9.7	-	-
373.10.C.S	Stainless Steel	RH	10	16	M10	16	47.0	35	15.5	47.5	20.0	16	12.0	-	-
373.12.C.S	Stainless Steel	RH	12	16	M12	16	47.0	35	15.5	47.5	20.0	16	12.0	-	-
374.05.C.S	Stainless Steel	LH	5	8	M5	8	28.5	22	10.5	25.0	10.2	9	6.4	-	-
374.06.C.S	Stainless Steel	LH	6	10	M6	10	32.5	25	11.5	30.0	12.5	11	7.5	-	-
374.08.C.S	Stainless Steel	LH	8	13	M8	13	39.5	30	14.0	38.0	16.5	13	9.7	-	-
374.10.C.S	Stainless Steel	LH	10	16	M10	16	47.0	35	15.5	47.5	20.0	16	12.0	-	-
374.12.C.S	Stainless Steel	LH	12	16	M12	16	47.0	35	15.5	47.5	20.0	16	12.0	-	-

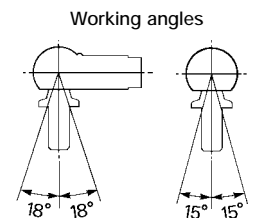
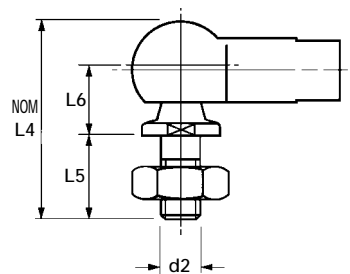
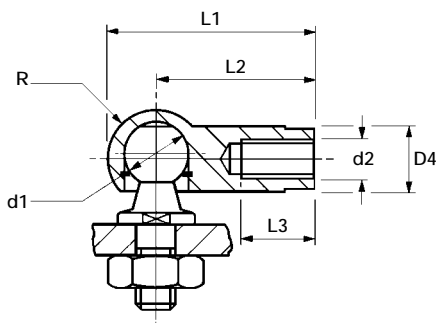

CLEVIS ASSEMBLIES

Short Series: Manufactured to DIN standard 71752, this series spans M4–M16.

Long Series: Manufactured with proportionately longer forks for greater reach or higher working angles, this series spans M4–M16 and conforms to DIN standard 71752.

Cetop Series: Manufactured with fine threads associated with pneumatic cylinders



Short Series
Code 351

Long Series
Code 352

Cetop Series
Code 353

Finish: The standard protective finish for all components in this range is zinc and clear passivate. Other finishes are available to order.

4

Material : Steel

Order Code	Series	Size	A	B	C	D	E	H9			h11						h10				+0.2 Y						
								øF	G	øH	J	K	L	øM	øN	øP	Q	øR	S	T		øU	øV	W	X		
351.04.C	Short Clevis	4	M4 × 0.7	21	8	8	4.14 / 4.26	4	6.0	8	16	-	-	-	-	-	-	-	-	-	-	-	-	-	-	-	-
351.05.C	Short Clevis	5	M5 × 0.8	26	10	10	5.14 / 5.26	5	7.5	9	20	-	-	-	-	-	-	-	-	-	-	-	-	-	-	-	-
351.06.C	Short Clevis	6	M6 × 1.0	31	12	12	6.14 / 6.26	6	9.0	10	24	-	-	-	-	-	-	-	-	-	-	-	-	-	-	-	-
351.08.C	Short Clevis	8	M8 × 1.25	42	16	16	8.15 / 8.30	8	12.0	14	32	-	-	-	-	-	-	-	-	-	-	-	-	-	-	-	-
351.10.C	Short Clevis	10	M10 × 1.50	52	20	20	10.15 / 10.30	10	15.0	18	40	-	-	-	-	-	-	-	-	-	-	-	-	-	-	-	-
351.12.C	Short Clevis	12	M12 × 1.75	62	24	24	12.15 / 12.33	12	18.0	20	48	-	-	-	-	-	-	-	-	-	-	-	-	-	-	-	-
351.16.C	Short Clevis	16	M16 × 2.00	83	32	32	16.15 / 16.33	16	24.0	26	64	-	-	-	-	-	-	-	-	-	-	-	-	-	-	-	-
355.04.C	Short Spring Clip Pin	4	-	-	-	-	-	-	-	-	-	15	9	4	-	-	-	-	-	-	-	-	-	-	-	-	-
355.05.C	Short Spring Clip Pin	5	-	-	-	-	-	-	-	-	-	19	12	5	-	-	-	-	-	-	-	-	-	-	-	-	-
355.06.C	Short Spring Clip Pin	6	-	-	-	-	-	-	-	-	-	23	14	6	-	-	-	-	-	-	-	-	-	-	-	-	-
355.08.C	Short Spring Clip Pin	8	-	-	-	-	-	-	-	-	-	31	19	8	-	-	-	-	-	-	-	-	-	-	-	-	-
355.10.C	Short Spring Clip Pin	10	-	-	-	-	-	-	-	-	-	39	23	10	-	-	-	-	-	-	-	-	-	-	-	-	-
355.12.C	Short Spring Clip Pin	12	-	-	-	-	-	-	-	-	-	47	28	12	-	-	-	-	-	-	-	-	-	-	-	-	-
355.16.C	Short Spring Clip Pin	16	-	-	-	-	-	-	-	-	-	62	36	16	-	-	-	-	-	-	-	-	-	-	-	-	-
357.05.C	Clevis Pin	5	-	-	-	-	-	-	-	-	-	-	-	-	5	1.5	12.0	8	1.5	15	-	-	-	-	-	-	-
357.06.C	Clevis Pin	6	-	-	-	-	-	-	-	-	-	-	-	-	6	2.0	15.0	9	1.5	18	-	-	-	-	-	-	-
357.08.C	Clevis Pin	8	-	-	-	-	-	-	-	-	-	-	-	-	8	2.0	19.5	12	2.0	23	-	-	-	-	-	-	-
357.10.C	Clevis Pin	10	-	-	-	-	-	-	-	-	-	-	-	-	10	3.0	24.5	14	2.0	29	-	-	-	-	-	-	-
357.12.C	Clevis Pin	12	-	-	-	-	-	-	-	-	-	-	-	-	12	3.0	29.5	16	3.0	35	-	-	-	-	-	-	-
357.16.C	Clevis Pin	16	-	-	-	-	-	-	-	-	-	-	-	-	16	4.0	37.5	20	3.0	45	-	-	-	-	-	-	-
358.10.C	Clevis Pin	10	-	-	-	-	-	-	-	-	-	-	-	-	-	-	-	-	-	-	-	10	9.6	1.1	25	20	
358.12.C	Clevis Pin	12	-	-	-	-	-	-	-	-	-	-	-	-	-	-	-	-	-	-	-	12	11.5	1.1	30	24	
358.16.C	Clevis Pin	16	-	-	-	-	-	-	-	-	-	-	-	-	-	-	-	-	-	-	-	16	15.2	1.1	39	32	
352.05.C	Long Clevis	5	M5 × 0.80	36	20	10	5.14 / 5.26	5	7.5	9	30	-	-	-	-	-	-	-	-	-	-	-	-	-	-	-	-
352.06.C	Long Clevis	6	M6 × 1.00	43	24	12	6.14 / 6.26	6	9.0	10	36	-	-	-	-	-	-	-	-	-	-	-	-	-	-	-	-
352.08.C	Long Clevis	8	M8 × 1.25	58	32	16	8.15 / 8.30	8	12.0	14	48	-	-	-	-	-	-	-	-	-	-	-	-	-	-	-	-
352.10.C	Long Clevis	10	M10 × 1.50	72	40	20	10.15 / 10.30	10	15.0	18	60	-	-	-	-	-	-	-	-	-	-	-	-	-	-	-	-
352.12.C	Long Clevis	12	M12 × 1.75	86	48	24	12.15 / 12.33	12	18.0	20	72	-	-	-	-	-	-	-	-	-	-	-	-	-	-	-	-
356.05.C	Long Spring Clip Pin	5	-	-	-	-	-	-	-	-	-	29	12	5	-	-	-	-	-	-	-	-	-	-	-	-	-
356.06.C	Long Spring Clip Pin	6	-	-	-	-	-	-	-	-	-	35	14	6	-	-	-	-	-	-	-	-	-	-	-	-	-
356.08.C	Long Spring Clip Pin	8	-	-	-	-	-	-	-	-	-	47	19	8	-	-	-	-	-	-	-	-	-	-	-	-	-
356.10.C	Long Spring Clip Pin	10	-	-	-	-	-	-	-	-	-	59	23	10	-	-	-	-	-	-	-	-	-	-	-	-	-
356.12.C	Long Spring Clip Pin	12	-	-	-	-	-	-	-	-	-	71	28	12	-	-	-	-	-	-	-	-	-	-	-	-	-
353.10.C	Cetop Clevis	10	M10 × 1.25	52	20	20	10.15 / 10.30	10	15.0	18	40	-	-	-	-	-	-	-	-	-	-	-	-	-	-	-	-
353.12.C	Cetop Clevis	12	M12 × 1.25	62	24	24	12.15 / 12.33	12	18.0	20	48	-	-	-	-	-	-	-	-	-	-	-	-	-	-	-	-
353.16.C	Cetop Clevis	16	M16 × 1.50	83	32	32	16.15 / 16.33	16	24.0	26	64	-	-	-	-	-	-	-	-	-	-	-	-	-	-	-	-
353.20.C	Cetop Clevis	20	M20 × 1.50	105	40	40	20.16 / 30.37	20	30.0	34	80	-	-	-	-	-	-	-	-	-	-	-	-	-	-	-	-
353.24.C	Cetop Clevis	24	M24 × 2.00	132	50	50	25.16 / 25.37	25	36.0	42	100	-	-	-	-	-	-	-	-	-	-	-	-	-	-	-	-

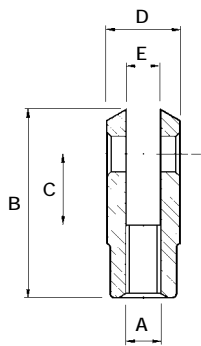

clevis

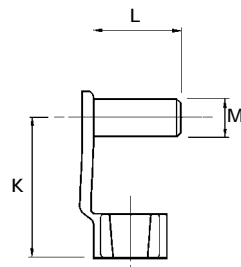
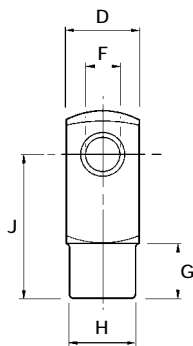

clevis pin - spring clip retention
Short Series Code 355
Long Series Code 356

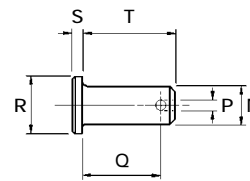

clevis pin - split pin retention
Code 357
DIN 1434

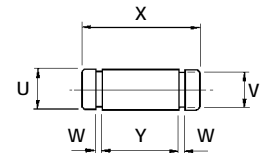

clevis pin - circlip retention
Code 358

STAINLESS STEEL

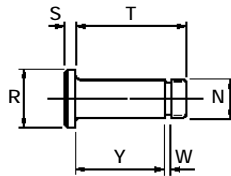
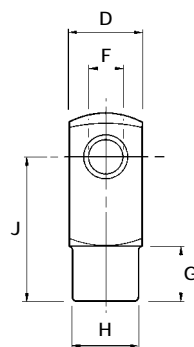
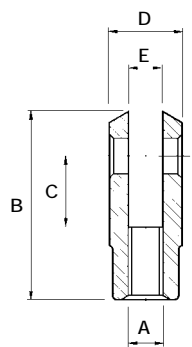

Material : Stainless Steel A ISI 303

Order Code	Series	Size	A	B	C	D	E	H9 øF	G	øH	J	h11 øN	øR	S	T	W	+0.2 Y
351.04.S	Short Clevis Assembly	4	M4 × 0.7	21	8	8	4.1 / 4.8	4	6.0	8	16	4	6	1	10	0.5	8
351.05.S	Short Clevis Assembly	5	M5 × 0.8	26	10	10	5.1 / 5.8	5	7.5	9	20	5	8	1.5	13	0.7	10
351.06.S	Short Clevis Assembly	6	M6 × 1.0	31	12	12	6.1 / 6.8	6	9.0	10	24	6	9	1.5	15	0.8	12
351.08.S	Short Clevis Assembly	8	M8 × 1.25	42	16	16	8.1 / 8.8	8	12.0	14	32	8	12	2	19.5	0.9	16
351.10.S	Short Clevis Assembly	10	M10 × 1.5	52	20	20	10.1 / 10.8	10	15.0	18	40	10	14	2	24.5	1.1	20
351.12.S	Short Clevis Assembly	12	M12 × 1.75	62	24	24	12.1 / 12.8	12	18.0	20	48	12	17	3	29	1.1	24
351.14.S	Short Clevis Assembly	14	M14 × 2.0	72	28	28	14.1 / 14.8	14	22.5	24	56	14	19	3	32.5	1.1	28
351.16.S	Short Clevis Assembly	16	M16 × 2.00	83	32	32	16.1 / 16.8	16	24.0	26	64	16	21	3	38	1.1	32
352.04.S	Long Clevis Assembly	4	M4 × 0.7	29	16	8	4.1 / 4.8	4	6.0	8	24	4	6	1	10	0.5	8
352.05.S	Long Clevis Assembly	5	M5 × 0.8	36	20	10	5.1 / 5.8	5	7.5	9	30	5	8	1.5	13	0.7	10
352.06.S	Long Clevis Assembly	6	M6 × 1.0	43	24	12	6.1 / 6.8	6	9.0	10	36	6	9	1.5	15	0.8	12
352.08.S	Long Clevis Assembly	8	M8 × 1.25	58	32	16	8.1 / 8.8	8	12.0	14	48	8	12	2	19.5	0.9	16
352.10.S	Long Clevis Assembly	10	M10 × 1.5	72	40	20	10.1 / 10.8	10	15.0	18	60	10	14	2	24.5	1.1	20
352.12.S	Long Clevis Assembly	12	M12 × 1.75	86	48	24	12.1 / 12.8	12	18.0	20	72	12	17	3	29	1.1	24
352.14.S	Long Clevis Assembly	14	M14 × 2.0	101	56	28	14.1 / 14.8	14	22.5	24	85	14	19	3	32.5	1.1	28
352.16.S	Long Clevis Assembly	16	M16 × 2.00	115	64	32	16.1 / 16.8	16	24.0	26	96	16	21	3	38	1.1	32

INTERESTED IN
OUR PRECISION
COUPLERS?

CALL OUR SALES
TEAM FOR MORE
INFORMATION AND
CATALOGUE

+44 (0)1992 509888