

# LF155/LF156/LF157 Series Monolithic JFET Input Operational Amplifiers

## General Description

These are the first monolithic JFET input operational amplifiers to incorporate well matched, high voltage JFETs on the same chip with standard bipolar transistors (BI-FET™ Technology). These amplifiers feature low input bias and offset currents/low offset voltage and offset voltage drift, coupled with offset adjust which does not degrade drift or common-mode rejection. The devices are also designed for high slew rate, wide bandwidth, extremely fast settling time, low voltage and current noise and a low 1/f noise corner.

## Advantages

- Replace expensive hybrid and module FET op amps
- Rugged JFETs allow blow-out free handling compared with MOSFET input devices
- Excellent for low noise applications using either high or low source impedance—very low 1/f corner
- Offset adjust does not degrade drift or common-mode rejection as in most monolithic amplifiers
- New output stage allows use of large capacitive loads (5,000 pF) without stability problems
- Internal compensation and large differential input voltage capability

## Applications

- Precision high speed integrators
- Fast D/A and A/D converters
- High impedance buffers
- Wideband, low noise, low drift amplifiers
- Logarithmic amplifiers

- Photocell amplifiers
- Sample and Hold circuits

## Common Features

(LF155A, LF156A, LF157A)

- Low input bias current 30 pA
- Low Input Offset Current 3 pA
- High input impedance  $10^{12}\Omega$
- Low input offset voltage 1 mV
- Low input offset voltage temp. drift  $3 \mu V/^{\circ}C$
- Low input noise current 0.01 pA/ $\sqrt{Hz}$
- High common-mode rejection ratio 100 dB
- Large dc voltage gain 108 dB

## Uncommon Features

|   | LF155A | LF156A | LF157A<br>( $A_V = 5$ ) | Units           |
|---|--------|--------|-------------------------|-----------------|
| ■ Extremely fast settling time to 0.01% | 4      | 1.5    | 1.5                     | $\mu s$         |
| ■ Fast slew rate                        | 5      | 12     | 50                      | V/ $\mu s$      |
| ■ Wide gain bandwidth                   | 2.5    | 5      | 20                      | MHz             |
| ■ Low input noise voltage               | 20     | 12     | 12                      | nV/ $\sqrt{Hz}$ |

## Simplified Schematic

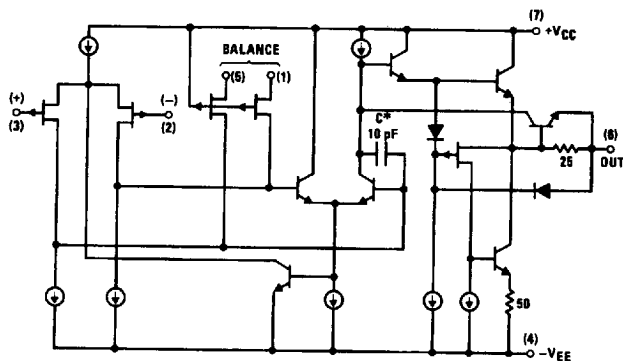

\*3 pF in LF157 series.

TL/H/5646-1

1

## Absolute Maximum Ratings

If Military/Aerospace specified devices are required, contact the National Semiconductor Sales Office/Distributors for availability and specifications.

(Note 8)

|   | LF155A/6A/7A    | LF155/6/7       | LF355B/6B/7B<br>LF255/6/7 | LF355/6/7<br>LF355A/6A/7A |
|---|-----------------|-----------------|---------------------------|---------------------------|
| Supply Voltage  | ±22V            | ±22V            | ±22V                      | ±18V                      |
| Differential Input Voltage  | ±40V            | ±40V            | ±40V                      | ±30V                      |
| Input Voltage Range (Note 2)  | ±20V            | ±20V            | ±20V                      | ±16V                      |
| Output Short Circuit Duration   | Continuous      | Continuous      | Continuous                | Continuous                |
| $T_{JMAX}$  |                 |                 |                           |                           |
| H-Package   | 150°C           | 150°C           | 115°C                     | 115°C                     |
| N-Package   |                 |                 | 100°C                     | 100°C                     |
| M-Package   |                 |                 | 100°C                     | 100°C                     |
| Power Dissipation at $T_A = 25^\circ\text{C}$ (Notes 1 and 9)   |                 |                 |                           |                           |
| H-Package (Still Air)   | 560 mW          | 560 mW          | 400 mW                    | 400 mW                    |
| H-Package (400 LF/Min Air Flow)   | 1200 mW         | 1200 mW         | 1000 mW                   | 1000 mW                   |
| N-Package   |                 |                 | 670 mW                    | 670 mW                    |
| M-Package   |                 |                 | 380 mW                    | 380 mW                    |
| Thermal Resistance (Typical) $\theta_{JA}$  |                 |                 |                           |                           |
| H-Package (Still Air)   | 160°C/W         | 160°C/W         | 160°C/W                   | 160°C/W                   |
| H-Package (400 LF/Min Air Flow)   | 65°C/W          | 65°C/W          | 65°C/W                    | 65°C/W                    |
| N-Package   |                 |                 | 130°C/W                   | 130°C/W                   |
| M-Package   |                 |                 | 195°C/W                   | 195°C/W                   |
| (Typical) $\theta_{JC}$   |                 |                 |                           |                           |
| H-Package   | 23°C/W          | 23°C/W          | 23°C/W                    | 23°C/W                    |
| Storage Temperature Range   | -65°C to +150°C | -65°C to +150°C | -65°C to +150°C           | -65°C to +150°C           |
| Soldering Information (Lead Temp.)  |                 |                 |                           |                           |
| Metal Can Package   |                 |                 |                           |                           |
| Soldering (10 sec.)   | 300°C           | 300°C           | 300°C                     | 300°C                     |
| Dual-In-Line Package  |                 |                 |                           |                           |
| Soldering (10 sec.)   |                 | 260°C           | 260°C                     | 260°C                     |
| Small Outline Package   |                 |                 |                           |                           |
| Vapor Phase (60 sec.)   |                 |                 | 215°C                     | 215°C                     |
| Infrared (15 sec.)  |                 |                 | 220°C                     | 220°C                     |
| See AN-450 "Surface Mounting Methods and Their Effect on Product Reliability" for other methods of soldering surface mount devices. |                 |                 |                           |                           |
| ESD tolerance   |                 |                 |                           |                           |
| (100 pF discharged through 1.5 k $\Omega$ )   | 1000V           | 1000V           | 1000V                     | 1000V                     |

## DC Electrical Characteristics (Note 3) $T_A = T_J = 25^\circ\text{C}$

| Symbol                    | Parameter                                 | Conditions  | LF155A/6A/7A |                  |          | LF355A/6A/7A |                  |          | Units                                  |
|---------------------------|---|---|--------------|------------------|----------|--------------|------------------|----------|--|
|                           |   |   | Min          | Typ              | Max      | Min          | Typ              | Max      |  |
| $V_{OS}$                  | Input Offset Voltage                      | $R_S = 50\Omega$ , $T_A = 25^\circ\text{C}$<br>Over Temperature   |              | 1                | 2<br>2.5 |              | 1                | 2<br>2.3 | mV<br>mV                               |
| $\Delta V_{OS}/\Delta T$  | Average TC of Input Offset Voltage        | $R_S = 50\Omega$  |              | 3                | 5        |              | 3                | 5        | $\mu\text{V}/^\circ\text{C}$           |
| $\Delta TC/\Delta V_{OS}$ | Change in Average TC with $V_{OS}$ Adjust | $R_S = 50\Omega$ , (Note 4)   |              | 0.5              |          |              | 0.5              |          | $\mu\text{V}/^\circ\text{C}$<br>per mV |
| $I_{OS}$                  | Input Offset Current                      | $T_J = 25^\circ\text{C}$ , (Notes 3, 5)<br>$T_J \leq T_{HIGH}$  |              | 3                | 10<br>10 |              | 3                | 10<br>1  | pA<br>nA                               |
| $I_B$                     | Input Bias Current                        | $T_J = 25^\circ\text{C}$ , (Notes 3, 5)<br>$T_J \leq T_{HIGH}$  |              | 30               | 50<br>25 |              | 30               | 50<br>5  | pA<br>nA                               |
| $R_{IN}$                  | Input Resistance                          | $T_J = 25^\circ\text{C}$  |              | 10 <sup>12</sup> |          |              | 10 <sup>12</sup> |          | $\Omega$                               |
| $A_{VOL}$                 | Large Signal Voltage Gain                 | $V_S = \pm 15\text{V}$ , $T_A = 25^\circ\text{C}$<br>$V_O = \pm 10\text{V}$ , $R_L = 2\text{k}$<br>Over Temperature | 50<br>25     | 200              |          | 50<br>25     | 200              |          | V/mV<br>V/mV                           |
| $V_O$                     | Output Voltage Swing                      | $V_S = \pm 15\text{V}$ , $R_L = 10\text{k}$<br>$V_S = \pm 15\text{V}$ , $R_L = 2\text{k}$                           | ±12<br>±10   | ±13<br>±12       |          | ±12<br>±10   | ±13<br>±12       |          | V<br>V                                 |

### DC Electrical Characteristics (Note 3) $T_A = T_j = 25^\circ\text{C}$ (Continued)

| Symbol   | Parameter                       | Conditions             | LF155A/6A/7A |              |     | LF355A/6A/7A |              |     | Units  |
|----------|---------------------------------|------------------------|--------------|--------------|-----|--------------|--------------|-----|--------|
|          |                                 |                        | Min          | Typ          | Max | Min          | Typ          | Max |        |
| $V_{CM}$ | Input Common-Mode Voltage Range | $V_S = \pm 15\text{V}$ | $\pm 11$     | +15.1<br>-12 |     | $\pm 11$     | +15.1<br>-12 |     | V<br>V |
| CMRR     | Common-Mode Rejection Ratio     |                        | 85           | 100          |     | 85           | 100          |     | dB     |
| PSRR     | Supply Voltage Rejection Ratio  | (Note 6)               | 85           | 100          |     | 85           | 100          |     | dB     |

### AC Electrical Characteristics $T_A = T_j = 25^\circ\text{C}$ , $V_S = \pm 15\text{V}$

| Symbol   | Parameter                      | Conditions   | LF155A/355A |              |     | LF156A/356A |              |     | LF157A/357A |              |     | Units  |
|----------|--------------------------------|--|-------------|--------------|-----|-------------|--------------|-----|-------------|--------------|-----|--|
|          |                                |  | Min         | Typ          | Max | Min         | Typ          | Max | Min         | Typ          | Max |  |
| SR       | Slew Rate                      | LF155A/6A; $A_V = 1$ ,<br>LF157A; $A_V = 5$                      | 3           | 5            |     | 10          | 12           |     | 40          | 50           |     | V/ $\mu\text{s}$<br>V/ $\mu\text{s}$             |
| GBW      | Gain Bandwidth Product         |  |             | 2.5          |     | 4           | 4.5          |     | 15          | 20           |     | MHz  |
| $t_s$    | Settling Time to 0.01%         | (Note 7)   |             | 4            |     |             | 1.5          |     |             | 1.5          |     | $\mu\text{s}$                                    |
| $e_n$    | Equivalent Input Noise Voltage | $R_S = 100\Omega$<br>$f = 100\text{ Hz}$<br>$f = 1000\text{ Hz}$ |             | 25<br>20     |     |             | 15<br>12     |     |             | 15<br>12     |     | nV/ $\sqrt{\text{Hz}}$<br>nV/ $\sqrt{\text{Hz}}$ |
| $i_n$    | Equivalent Input Noise Current | $f = 100\text{ Hz}$<br>$f = 1000\text{ Hz}$                      |             | 0.01<br>0.01 |     |             | 0.01<br>0.01 |     |             | 0.01<br>0.01 |     | pA/ $\sqrt{\text{Hz}}$<br>pA/ $\sqrt{\text{Hz}}$ |
| $C_{IN}$ | Input Capacitance              |  |             | 3            |     |             | 3            |     |             | 3            |     | pF   |

### DC Electrical Characteristics (Note 3)

| Symbol                    | Parameter                                 | Conditions  | LF155/6/7            |                      |           | LF255/6/7<br>LF355B/6B/7B |                      |          | LF355/6/7            |                      |          | Units                                  |
|---------------------------|---|---|----------------------|----------------------|-----------|---------------------------|----------------------|----------|----------------------|----------------------|----------|--|
|                           |   |   | Min                  | Typ                  | Max       | Min                       | Typ                  | Max      | Min                  | Typ                  | Max      |  |
| $V_{OS}$                  | Input Offset Voltage                      | $R_S = 50\Omega$ , $T_A = 25^\circ\text{C}$<br>Over Temperature   |                      | 3                    | 5<br>7    |                           | 3                    | 5<br>6.5 |                      | 3                    | 10<br>13 | mV<br>mV                               |
| $\Delta V_{OS}/\Delta T$  | Average TC of Input Offset Voltage        | $R_S = 50\Omega$  |                      | 5                    |           |                           | 5                    |          |                      | 5                    |          | $\mu\text{V}/^\circ\text{C}$           |
| $\Delta TC/\Delta V_{OS}$ | Change in Average TC with $V_{OS}$ Adjust | $R_S = 50\Omega$ , (Note 4)   |                      | 0.5                  |           |                           | 0.5                  |          |                      | 0.5                  |          | $\mu\text{V}/^\circ\text{C}$<br>per mV |
| $I_{OS}$                  | Input Offset Current                      | $T_j = 25^\circ\text{C}$ , (Notes 3, 5)<br>$T_j \leq T_{HIGH}$  |                      | 3                    | 20<br>20  |                           | 3                    | 20<br>1  |                      | 3                    | 50<br>2  | pA<br>nA                               |
| $I_B$                     | Input Bias Current                        | $T_j = 25^\circ\text{C}$ , (Notes 3, 5)<br>$T_j \leq T_{HIGH}$  |                      | 30                   | 100<br>50 |                           | 30                   | 100<br>5 |                      | 30                   | 200<br>8 | pA<br>nA                               |
| $R_{IN}$                  | Input Resistance                          | $T_j = 25^\circ\text{C}$  |                      | 10 <sup>12</sup>     |           |                           | 10 <sup>12</sup>     |          |                      | 10 <sup>12</sup>     |          | $\Omega$                               |
| $A_{VOL}$                 | Large Signal Voltage Gain                 | $V_S = \pm 15\text{V}$ , $T_A = 25^\circ\text{C}$<br>$V_O = \pm 10\text{V}$ , $R_L = 2\text{k}$<br>Over Temperature | 50                   | 200                  |           | 50                        | 200                  |          | 25                   | 200                  |          | V/mV<br>V/mV                           |
| $V_O$                     | Output Voltage Swing                      | $V_S = \pm 15\text{V}$ , $R_L = 10\text{k}$<br>$V_S = \pm 15\text{V}$ , $R_L = 2\text{k}$                           | $\pm 12$<br>$\pm 10$ | $\pm 13$<br>$\pm 12$ |           | $\pm 12$<br>$\pm 10$      | $\pm 13$<br>$\pm 12$ |          | $\pm 12$<br>$\pm 10$ | $\pm 13$<br>$\pm 12$ |          | V<br>V                                 |
| $V_{CM}$                  | Input Common-Mode Voltage Range           | $V_S = \pm 15\text{V}$  | $\pm 11$             | +15.1<br>-12         |           | $\pm 11$                  | $\pm 15.1$<br>-12    |          | +10                  | +15.1<br>-12         |          | V<br>V                                 |
| CMRR                      | Common-Mode Rejection Ratio               |   | 85                   | 100                  |           | 85                        | 100                  |          | 80                   | 100                  |          | dB                                     |
| PSRR                      | Supply Voltage Rejection Ratio            | (Note 6)  | 85                   | 100                  |           | 85                        | 100                  |          | 80                   | 100                  |          | dB                                     |



6501124 0094328 T31

### DC Electrical Characteristics $T_A = T_j = 25^\circ\text{C}, V_S = \pm 15\text{V}$

| Parameter      | LF155A/155, LF255, LF355A/355B |     | LF355 |     | LF156A/156, LF256/356B |     | LF356A/356 |     | LF157A/157, LF257/357B |     | LF357A/357 |     | Units |
|----------------|--------------------------------|-----|-------|-----|------------------------|-----|------------|-----|------------------------|-----|------------|-----|-------|
|                | Typ                            | Max | Typ   | Max | Typ                    | Max | Typ        | Max | Typ                    | Max | Typ        | Max |       |
| Supply Current | 2                              | 4   | 2     | 4   | 5                      | 7   | 5          | 10  | 5                      | 7   | 5          | 10  | mA    |

### AC Electrical Characteristics $T_A = T_j = 25^\circ\text{C}, V_S = \pm 15\text{V}$

| Symbol   | Parameter                      | Conditions   | LF155/255/355/355B | LF156/256, LF356B | LF156/256/356/356B | LF157/257, LF357B | LF157/257/357/357B | Units  |
|----------|--------------------------------|--|--------------------|-------------------|--------------------|-------------------|--------------------|--|
|          |                                |  | Typ                | Min               | Typ                | Min               | Typ                |  |
| SR       | Slew Rate                      | LF155/6: $A_V = 1$ ,<br>LF157: $A_V = 5$                         | 5                  | 7.5               | 12                 | 30                | 50                 | V/ $\mu\text{s}$<br>V/ $\mu\text{s}$             |
| GBW      | Gain Bandwidth Product         |  | 2.5                |                   | 5                  |                   | 20                 | MHz  |
| $t_s$    | Settling Time to 0.01%         | (Note 7)   | 4                  |                   | 1.5                |                   | 1.5                | $\mu\text{s}$                                    |
| $e_n$    | Equivalent Input Noise Voltage | $R_S = 100\Omega$<br>$f = 100\text{ Hz}$<br>$f = 1000\text{ Hz}$ | 25<br>20           |                   | 15<br>12           |                   | 15<br>12           | nV/ $\sqrt{\text{Hz}}$<br>nV/ $\sqrt{\text{Hz}}$ |
| $i_n$    | Equivalent Input Current Noise | $f = 100\text{ Hz}$<br>$f = 1000\text{ Hz}$                      | 0.01<br>0.01       |                   | 0.01<br>0.01       |                   | 0.01<br>0.01       | pA/ $\sqrt{\text{Hz}}$<br>pA/ $\sqrt{\text{Hz}}$ |
| $C_{IN}$ | Input Capacitance              |  | 3                  |                   | 3                  |                   | 3                  | pF   |

### Notes for Electrical Characteristics

**Note 1:** The maximum power dissipation for these devices must be derated at elevated temperatures and is dictated by  $T_{jMAX}$ ,  $\theta_{JA}$ , and the ambient temperature,  $T_A$ . The maximum available power dissipation at any temperature is  $P_d = (T_{jMAX} - T_A) / \theta_{JA}$  or the  $25^\circ\text{C}$   $P_{dMAX}$ , whichever is less.

**Note 2:** Unless otherwise specified the absolute maximum negative input voltage is equal to the negative power supply voltage.

**Note 3:** Unless otherwise stated, these test conditions apply:

|                       | LF155A/6A/7A<br>LF155/6/7                            | LF255/6/7   | LF355A/6A/7A                                      | LF355B/6B/7B                                      | LF355/6/7   |
|-----------------------|--|---|---|---|---|
| Supply Voltage, $V_S$ | $\pm 15\text{V} \leq V_S \leq \pm 20\text{V}$        | $\pm 15\text{V} \leq V_S \leq \pm 20\text{V}$       | $\pm 15\text{V} \leq V_S \leq \pm 18\text{V}$     | $\pm 15\text{V} \leq V_S \leq \pm 20\text{V}$     | $V_S = \pm 15\text{V}$                            |
| $T_A$                 | $-55^\circ\text{C} \leq T_A \leq +125^\circ\text{C}$ | $-25^\circ\text{C} \leq T_A \leq +85^\circ\text{C}$ | $0^\circ\text{C} \leq T_A \leq +70^\circ\text{C}$ | $0^\circ\text{C} \leq T_A \leq +70^\circ\text{C}$ | $0^\circ\text{C} \leq T_A \leq +70^\circ\text{C}$ |
| $T_{HIGH}$            | $+125^\circ\text{C}$                                 | $+85^\circ\text{C}$                                 | $+70^\circ\text{C}$                               | $+70^\circ\text{C}$                               | $+70^\circ\text{C}$                               |

and  $V_{OS}$ ,  $I_B$  and  $I_{OS}$  are measured at  $V_{CM} = 0$ .

**Note 4:** The Temperature Coefficient of the adjusted input offset voltage changes only a small amount ( $0.5\mu\text{V}/^\circ\text{C}$  typically) for each mV of adjustment from its original unadjusted value. Common-mode rejection and open loop voltage gain are also unaffected by offset adjustment.

**Note 5:** The input bias currents are junction leakage currents which approximately double for every  $10^\circ\text{C}$  increase in the junction temperature,  $T_j$ . Due to limited voltage at the inverting input pin on the amplifier) to settle to within 0.01% of its final value from the time a 10V step input is applied to the inverter. For the LF157,  $A_V = -5$ , the feedback resistor from output to input is  $2\text{ k}\Omega$  and the output step is 10V (See Settling Time Test Circuit).

**Note 6:** Supply Voltage Rejection is measured for both supply magnitudes increasing or decreasing simultaneously, in accordance with common practice.

**Note 7:** Settling time is defined here, for a unity gain inverter connection using  $2\text{ k}\Omega$  resistors for the LF155/6. It is the time required for the error voltage (the voltage at the inverting input pin on the amplifier) to settle to within 0.01% of its final value from the time a 10V step input is applied to the inverter. For the LF157,  $A_V = -5$ , the feedback resistor from output to input is  $2\text{ k}\Omega$  and the output step is 10V (See Settling Time Test Circuit).

**Note 8:** Refer to RETS155AX for LF155A, RETS155X for LF155, RETS156AX for LF156A, RETS156X for LF156, RETS157A for LF157A and RETS157X for LF157 military specifications.

**Note 9:** Max. Power Dissipation is defined by the package characteristics. Operating the part near the Max. Power Dissipation may cause the part to operate outside guaranteed limits.

# Typical DC Performance Characteristics

Curves are for LF155, LF156 and LF157 unless otherwise specified.

**Input Bias Current**

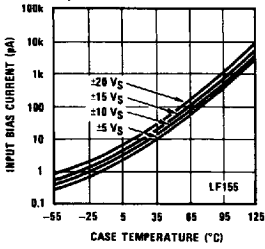

**Input Bias Current**

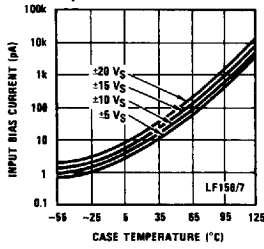

**Input Bias Current**

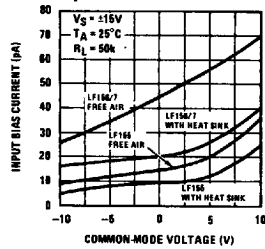

**Voltage Swing**

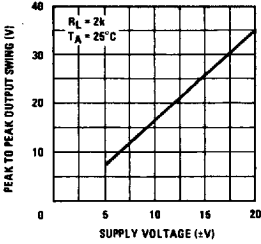

**Supply Current**

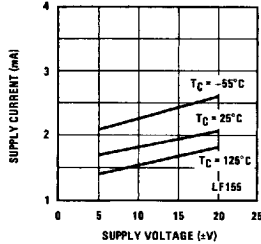

**Supply Current**

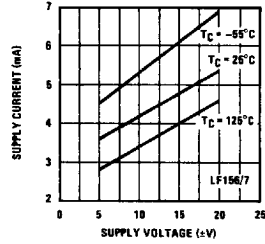

**Negative Current Limit**

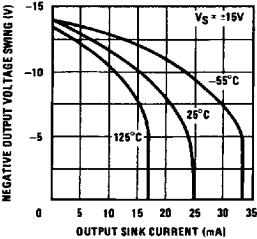

**Positive Current Limit**

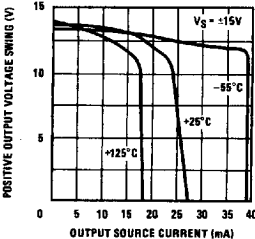

**Positive Common-Mode Input Voltage Limit**

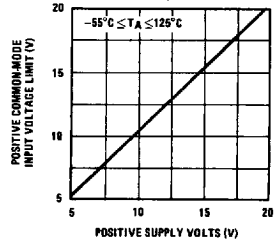

**Negative Common-Mode Input Voltage Limit**

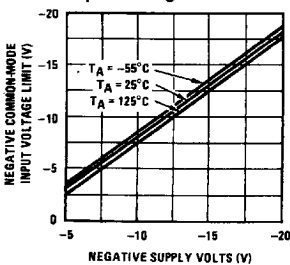

**Open Loop Voltage Gain**

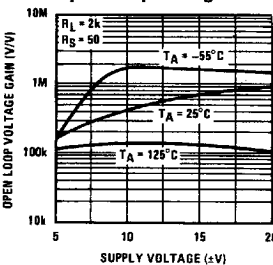

**Output Voltage Swing**

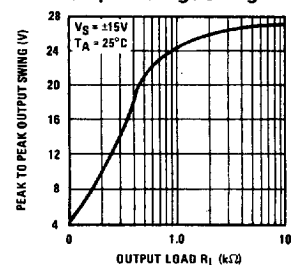

TL/H/5646-2

TL/H/5646-3

# Typical AC Performance Characteristics

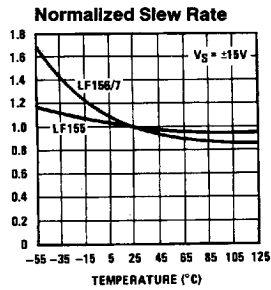
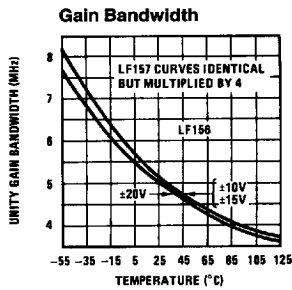
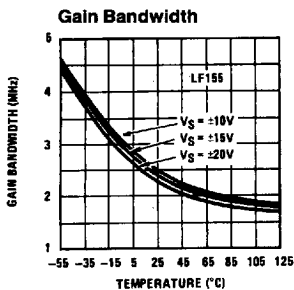

TL/H/5646-4

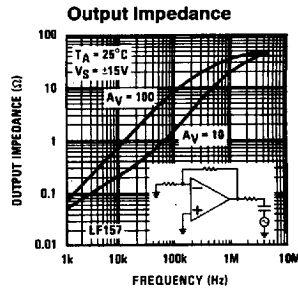
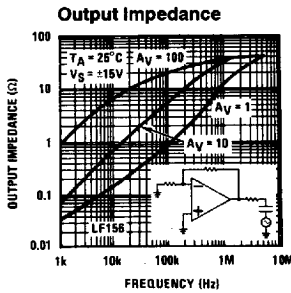
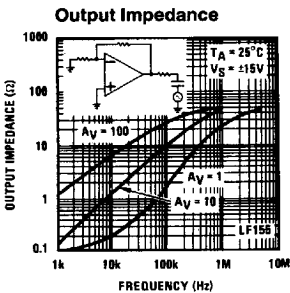

TL/H/5646-12

**LF155 Small Signal Pulse Response,  $A_V = +1$**

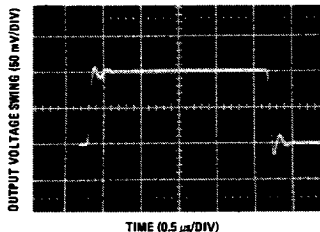

TL/H/5646-5

**LF156 Small Signal Pulse Response,  $A_V = +1$**

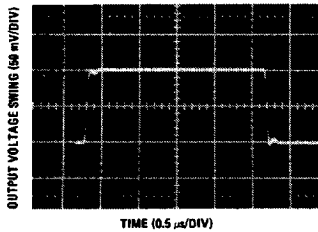

TL/H/5646-6

**Small Signal Pulse Response,  $A_V = +5$**

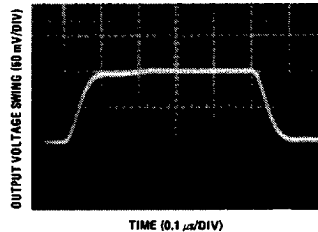

TL/H/5646-7

**LF155 Large Signal Pulse Response,  $A_V = +1$**

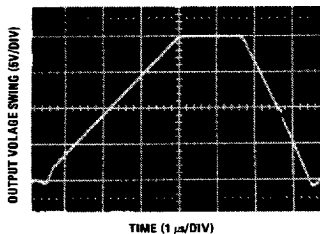

TL/H/5646-8

**LF156 Large Signal Pulse Response,  $A_V = +1$**

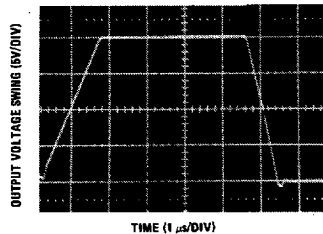

TL/H/5646-9

**LF157 Large Signal Pulse Response,  $A_V = +5$**

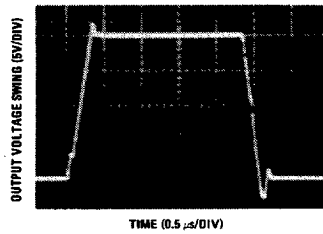

TL/H/5646-10

# Typical AC Performance Characteristics (Continued)

LF155/LF156/LF157

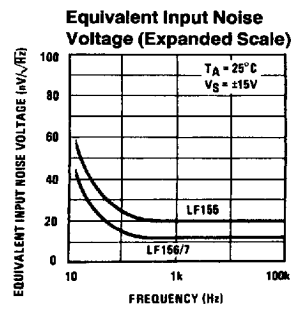
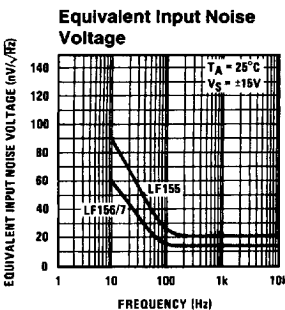
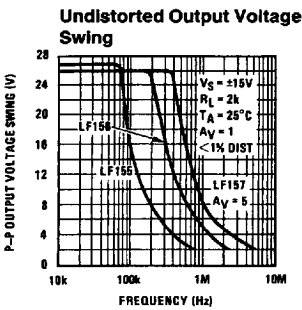
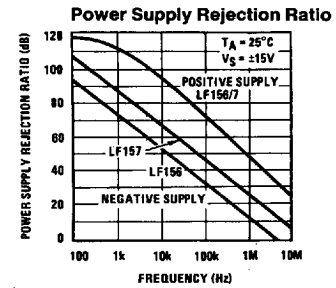
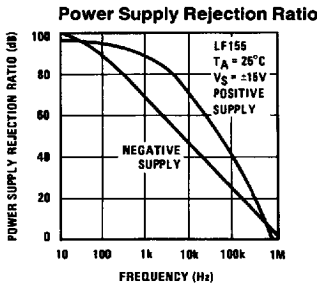
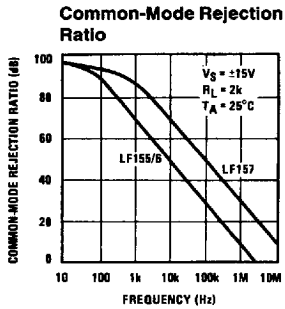
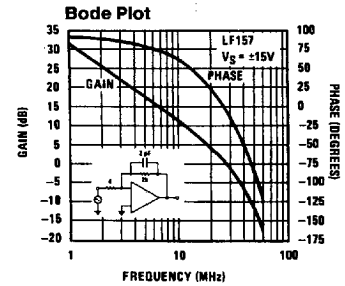
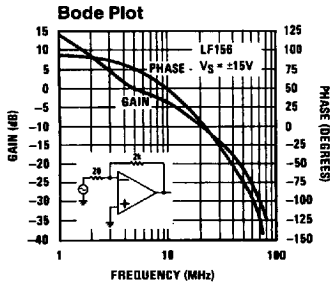
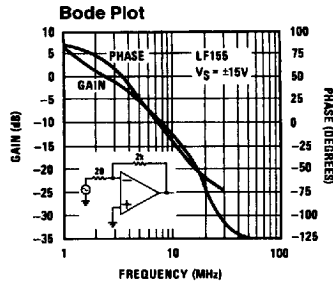
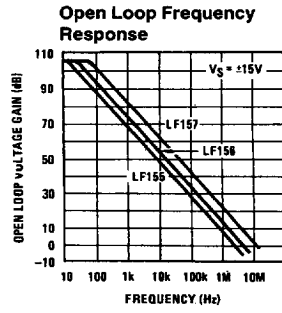
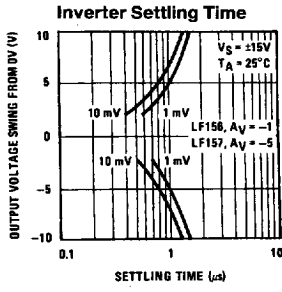
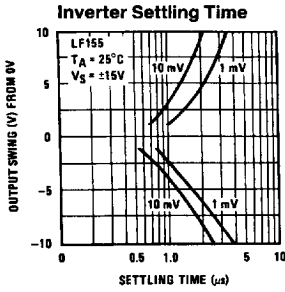

TL/H/5646-11

# Detailed Schematic

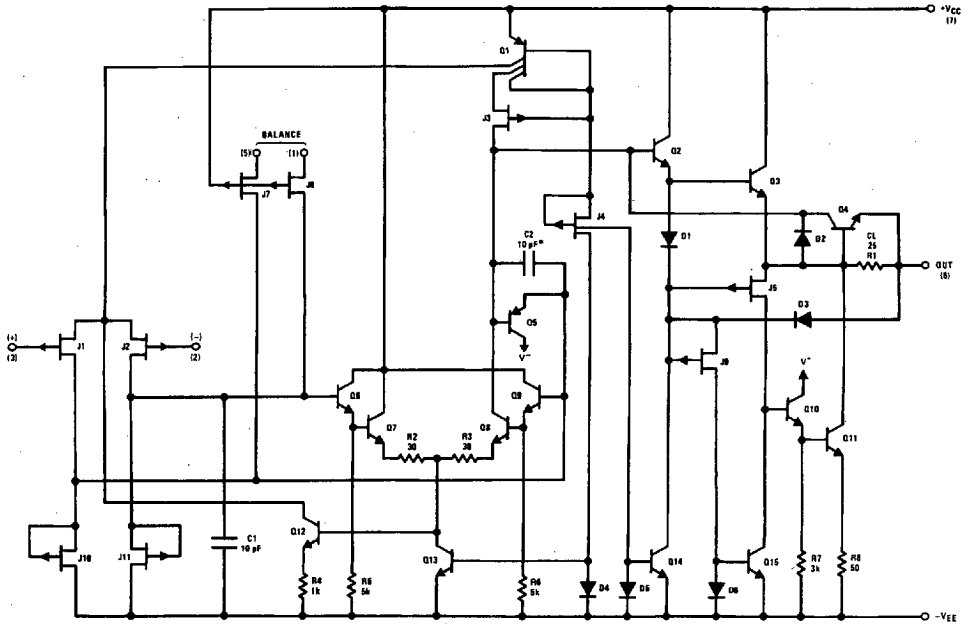

\*C = 3 pF in LF157 series.

TL/H/5646-13

## Connection Diagrams (Top Views)

### Metal Can Package (H)

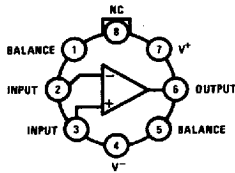

TL/H/5646-14

Order Number LF156AH, LF155H, LF156H, LF255H, LF256H, LF257H, LF355AH, LF356AH, LF357AH, LF356BH, LF355H, LF356H, LF357H, LM155AH/883, LM155H/883, LM156AH/883, LM156H/883, LM157AH/883 or LM157H/883\*  
See NS Package Number H08C

### Dual-In-Line Package (M and N)

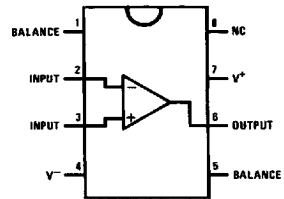

TL/H/5646-29

Order Number LF355M, LF356M, LF357M, LF355BM, LF356BM, LF355BN, LF356BN, LF357BN, LF355N, LF356N or LF357N  
See NS Package Number M08A or N08E

\*Available per JM38510/11401 or JM38510/11402

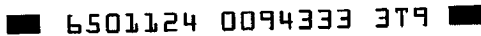



## Application Hints

The LF155/6/7 series are op amps with JFET input devices. These JFETs have large reverse breakdown voltages from gate to source and drain eliminating the need for clamps across the inputs. Therefore large differential input voltages can easily be accommodated without a large increase in input current. The maximum differential input voltage is independent of the supply voltages. However, neither of the input voltages should be allowed to exceed the negative supply as this will cause large currents to flow which can result in a destroyed unit.

Exceeding the negative common-mode limit on either input will force the output to a high state, potentially causing a reversal of phase to the output. Exceeding the negative common-mode limit on both inputs will force the amplifier output to a high state. In neither case does a latch occur since raising the input back within the common-mode range again puts the input stage and thus the amplifier in a normal operating mode.

Exceeding the positive common-mode limit on a single input will not change the phase of the output however, if both inputs exceed the limit, the output of the amplifier will be forced to a high state.

These amplifiers will operate with the common-mode input voltage equal to the positive supply. In fact, the common-mode voltage can exceed the positive supply by approximately 100 mV independent of supply voltage and over the full operating temperature range. The positive supply can therefore be used as a reference on an input as, for example, in a supply current monitor and/or limiter.

Precautions should be taken to ensure that the power supply for the integrated circuit never becomes reversed in polarity or that the unit is not inadvertently installed backwards in a socket as an unlimited current surge through the resulting forward diode within the IC could cause fusing of the internal conductors and result in a destroyed unit.

All of the bias currents in these amplifiers are set by FET current sources. The drain currents for the amplifiers are therefore essentially independent of supply voltage.

As with most amplifiers, care should be taken with lead dress, component placement and supply decoupling in order to ensure stability. For example, resistors from the output to an input should be placed with the body close to the input to minimize "pickup" and maximize the frequency of the feedback pole by minimizing the capacitance from the input to ground.

A feedback pole is created when the feedback around any amplifier is resistive. The parallel resistance and capacitance from the input of the device (usually the inverting input) to ac ground set the frequency of the pole. In many instances the frequency of this pole is much greater than the expected 3 dB frequency of the closed loop gain and consequently there is negligible effect on stability margin. However, if the feedback pole is less than approximately six times the expected 3 dB frequency a lead capacitor should be placed from the output to the input of the op amp. The value of the added capacitor should be such that the RC time constant of this capacitor and the resistance it parallels is greater than or equal to the original feedback pole time constant.

## Typical Circuit Connections

V<sub>OS</sub> Adjustment

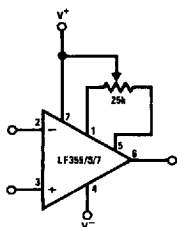

- V<sub>OS</sub> is adjusted with a 25k potentiometer
- The potentiometer wiper is connected to V<sup>+</sup>
- For potentiometers with temperature coefficient of 100 ppm/°C or less the additional drift with adjust is  $\approx 0.5 \mu\text{V}/^\circ\text{C}/\text{mV}$  of adjustment
- Typical overall drift:  $5 \mu\text{V}/^\circ\text{C} \pm (0.5 \mu\text{V}/^\circ\text{C}/\text{mV}$  of adj.)

Driving Capacitive Loads

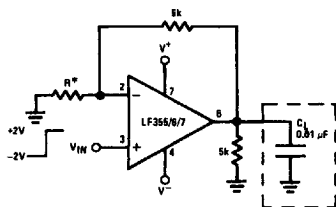

\*LF155/6 R = 5k  
LF157 R = 1.25k

Due to a unique output stage design, these amplifiers have the ability to drive large capacitive loads and still maintain stability.  $C_{L(\text{MAX})} \approx 0.01 \mu\text{F}$ .

Overshoot  $\leq 20\%$   
Settling time ( $t_s$ )  $\approx 5 \mu\text{s}$

LF157. A Large Power BW Amplifier

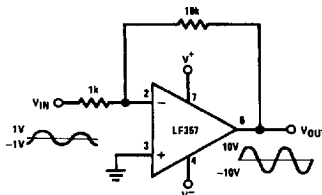

TL/H/5646-15  
For distortion  $\leq 1\%$  and a 20 Vp-p V<sub>OUT</sub> swing, power bandwidth is: 500 kHz.

1

# Typical Applications

## Settling Time Test Circuit

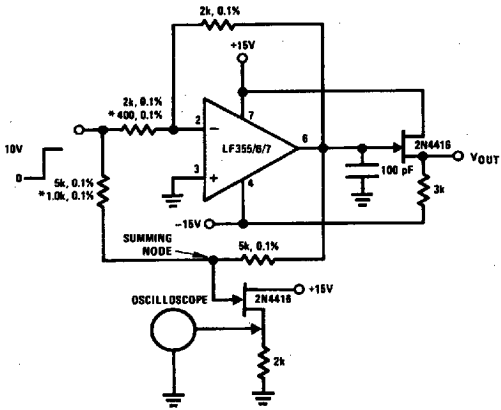

- Settling time is tested with the LF155/6 connected as unity gain inverter and LF157 connected for  $A_v = -5$
- FET used to isolate the probe capacitance
- Output = 10V step
- $A_v = -5$  for LF157

TL/H/5646-16

## Large Signal Inverter Output, $V_{OUT}$ (from Settling Time Circuit)

LF355

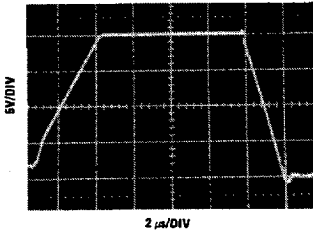

TL/H/5646-17

LF356

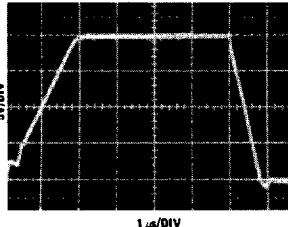

TL/H/5646-18

LF357

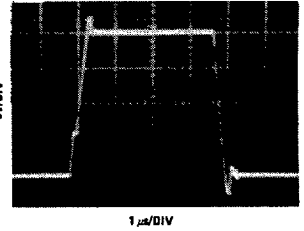

TL/H/5646-19

## Low Drift Adjustable Voltage Reference

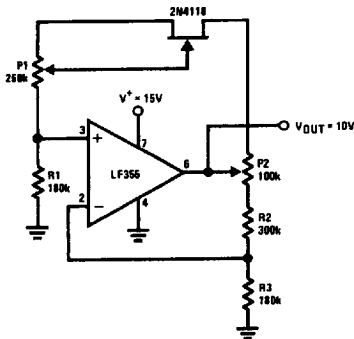

TL/H/5646-20

- $\Delta V_{OUT}/\Delta T = \pm 0.002\%/^{\circ}\text{C}$
- All resistors and potentiometers should be wire-wound
- P1: drift adjust
- P2:  $V_{OUT}$  adjust
- Use LF155 for
  - Low  $I_B$
  - Low drift
  - Low supply current

Typical Applications (Continued)

Fast Logarithmic Converter

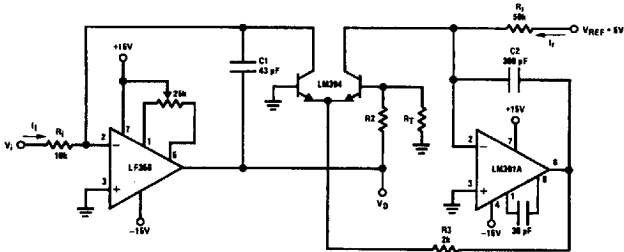

TL/H/5646-21

$$|V_{OUT}| = \left[ 1 + \frac{R_2}{R_T} \right] \frac{kT}{q} \ln V_i \left[ \frac{R_T}{V_{REF} R_1} \right] = \log V_i \frac{1}{R_1 R_T} R_2 = 15.7k, R_T = 1k, 0.3\%/^{\circ}C \text{ (for temperature compensation)}$$

- Dynamic range:  $100 \mu A \leq I_i \leq 1 \text{ mA}$  (5 decades),  $|V_O| = 1V/\text{decade}$
- Transient response:  $3 \mu s$  for  $\Delta I_i = 1 \text{ decade}$
- C1, C2, R2, R3: added dynamic compensation
- $V_{OS}$  adjust the LF156 to minimize quiescent error
- $R_T$ : Tel Labs type Q81 + 0.3%/°C

Precision Current Monitor

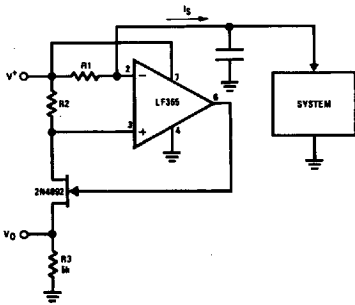

TL/H/5646-31

- $V_O = 5 R_1/R_2$  (V/mA of  $I_B$ )
- R1, R2, R3: 0.1% resistors
- Use LF155 for
  - Common-mode range to supply range
  - Low  $I_B$
  - Low  $V_{OS}$
  - Low Supply Current

8-Bit D/A Converter with Symmetrical Offset Binary Operation

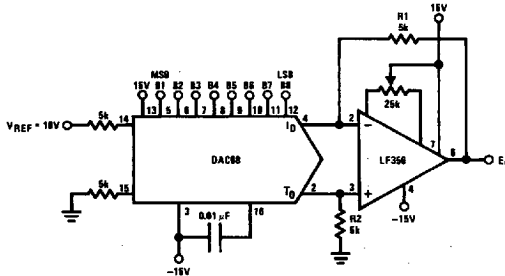

TL/H/5646-32

- R1, R2 should be matched within  $\pm 0.05\%$
- Full-scale response time:  $3 \mu s$

| $E_0$  | B1 | B2 | B3 | B4 | B5 | B6 | B7 | B8 | Comments            |
|--------|----|----|----|----|----|----|----|----|---------------------|
| +9.920 | 1  | 1  | 1  | 1  | 1  | 1  | 1  | 1  | Positive Full-Scale |
| +0.040 | 1  | 0  | 0  | 0  | 0  | 0  | 0  | 0  | (+) Zero-Scale      |
| -0.040 | 0  | 1  | 1  | 1  | 1  | 1  | 1  | 1  | (-) Zero-Scale      |
| -9.920 | 0  | 0  | 0  | 0  | 0  | 0  | 0  | 0  | Negative Full-Scale |

## Typical Applications (Continued)

### Wide BW Low Noise, Low Drift Amplifier

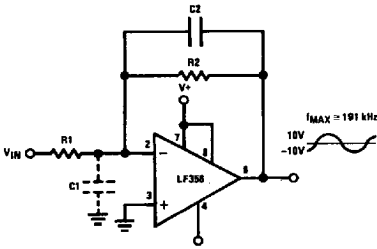

- Power BW:  $f_{MAX} = \frac{S_r}{2\pi V_P} \approx 191 \text{ kHz}$
- Parasitic input capacitance  $C_1 \approx (3 \text{ pF for LF155, LF156 and LF157 plus any additional layout capacitance})$  interacts with feedback elements and creates undesirable high frequency pole. To compensate add  $C_2$  such that:  $R_2 C_2 \approx R_1 C_1$ .

### Boosting the LF156 with a Current Amplifier

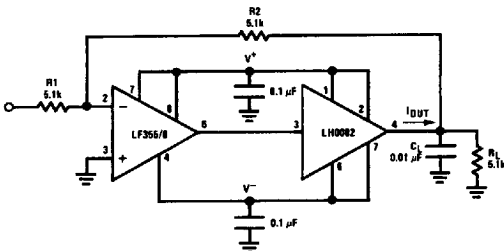

- $I_{OUT(MAX)} \approx 150 \text{ mA}$  (will drive  $R_L \geq 100\Omega$ )
- $\frac{\Delta V_{OUT}}{\Delta T} = \frac{0.15}{10^{-2}} \text{ V}/\mu\text{s}$  (with  $C_L$  shown)
- No additional phase shift added by the current amplifier

### 3 Decades VCO

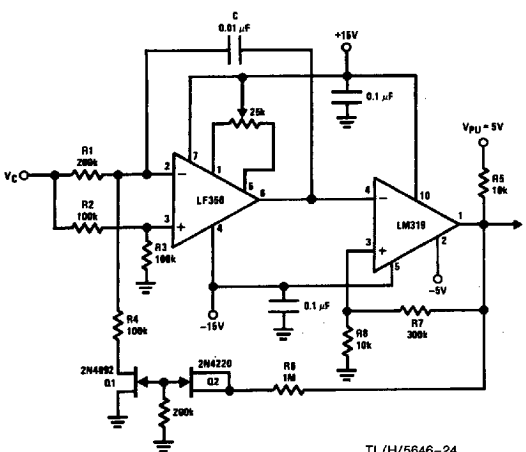

TL/H/5646-24

$$f = \frac{V_C (R_8 + R_7)}{(8 V_{PU} R_8 R_1) C} \quad 0 \leq V_C \leq 30\text{V}, 10 \text{ Hz} \leq f \leq 10 \text{ kHz}$$

$R_1, R_4$  matched. Linearity 0.1% over 2 decades.

### Isolating Large Capacitive Loads

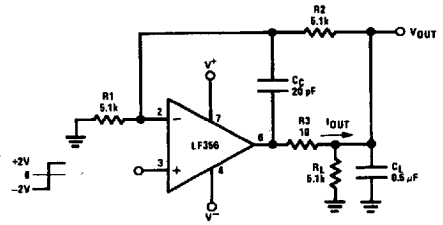

- Overshoot 6%
- $t_s \approx 10 \mu\text{s}$
- When driving large  $C_L$ , the  $V_{OUT}$  slew rate determined by  $C_L$  and  $I_{OUT(MAX)}$ :

$$\frac{\Delta V_{OUT}}{\Delta T} = \frac{I_{OUT}}{C_L} \approx \frac{0.02}{0.5} \text{ V}/\mu\text{s} = 0.04 \text{ V}/\mu\text{s} \text{ (with } C_L \text{ shown)}$$

TL/H/5646-22

### Low Drift Peak Detector

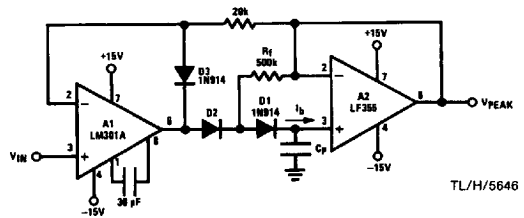

TL/H/5646

- By adding  $D_1$  and  $R_f$ ,  $V_{D1} = 0$  during hold mode. Leakage of  $D_2$  provided by feedback path through  $R_f$ .
- Leakage of circuit is essentially  $I_b$  (LF155, LF156) plus capacitor leakage of  $C_p$ .
- Diode  $D_3$  clamps  $V_{OUT}$  (A1) to  $V_{IN} - V_{D3}$  to improve speed and to limit reverse bias of  $D_2$ .
- Maximum input frequency should be  $\ll \frac{1}{2\pi R_f C_{D2}}$  where  $C_{D2}$  is the shunt capacitance of  $D_2$ .

### Non-Inverting Unity Gain Operation for LF157

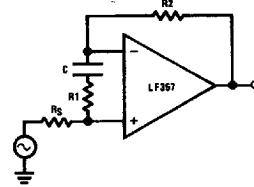

$$R1C \geq \frac{1}{(2\pi) (5 \text{ MHz})}$$

$$R1 = \frac{R2 + R_S}{4}$$

$$A_{V(DC)} = 1$$

$$f_{-3 \text{ dB}} \approx 5 \text{ MHz}$$

### Inverting Unity Gain for LF157

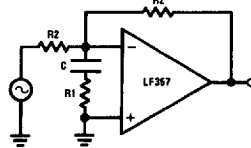

$$R1C \geq \frac{1}{(2\pi) (5 \text{ MHz})}$$

$$R1 = \frac{R_2}{4}$$

$$A_{V(DC)} = -1$$

$$f_{-3 \text{ dB}} \approx 5 \text{ MHz}$$

TL/H/5646-25

# Typical Applications (Continued)

LF155/LF156/LF157

## High Impedance, Low Drift Instrumentation Amplifier

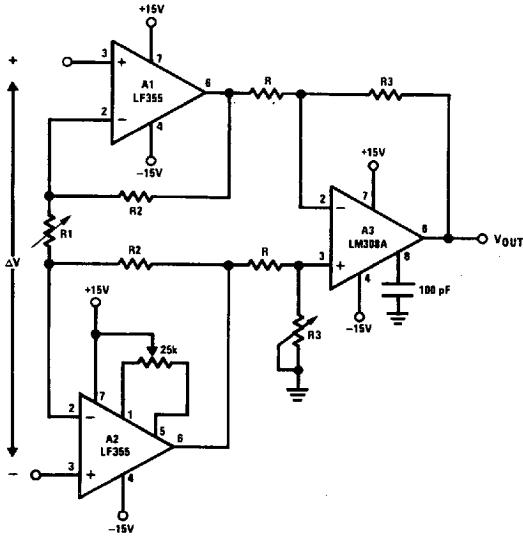

TL/H/5646-26

- $V_{OUT} = \frac{R_3}{R} \left[ \frac{2R_2}{R_1} + 1 \right] \Delta V, V^- + 2V \leq V_{IN \text{ common-mode}} \leq V^+$
- System  $V_{OS}$  adjusted via A2  $V_{OS}$  adjust
- Trim  $R_3$  to boost up CMRR to 120 dB. Instrumentation amplifier resistor array recommended for best accuracy and lowest drift

1

## Typical Applications (Continued)

### Fast Sample and Hold

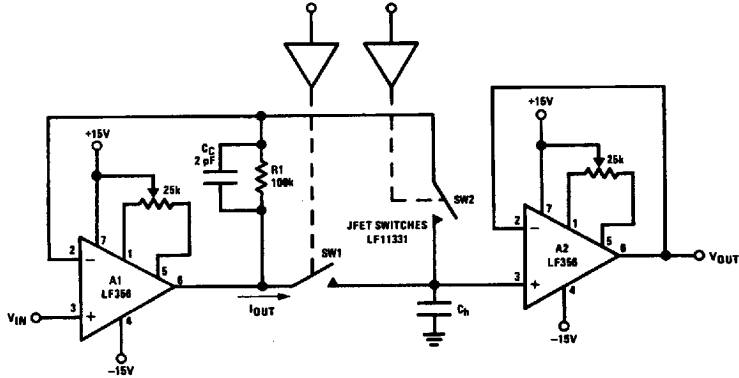

TL/H/5646-33

- Both amplifiers (A1, A2) have feedback loops individually closed with stable responses (overshoot negligible)
- Acquisition time  $T_A$ , estimated by:

$$T_A \approx \left[ \frac{2R_{ON} V_{IN} C_H}{S_r} \right]^{1/2} \text{ provided that:}$$

$$V_{IN} < 2\pi S_r R_{ON} C_H \text{ and } T_A > \frac{V_{IN} C_H}{I_{OUT(MAX)}} \text{, } R_{ON} \text{ is of SW1}$$

$$\text{If inequality not satisfied: } T_A \approx \frac{V_{IN} C_H}{20 \text{ mA}}$$

- LF156 develops full  $S_r$  output capability for  $V_{IN} \geq 1V$
- Addition of SW2 improves accuracy by putting the voltage drop across SW1 inside the feedback loop
- Overall accuracy of system determined by the accuracy of both amplifiers, A1 and A2

### High Accuracy Sample and Hold

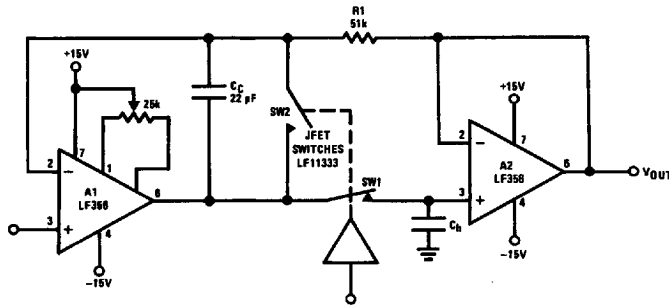

TL/H/5646-27

- By closing the loop through A2, the  $V_{OUT}$  accuracy will be determined uniquely by A1. No  $V_{OS}$  adjust required for A2.
- $T_A$  can be estimated by same considerations as previously but, because of the added propagation delay in the feedback loop (A2) the overshoot is not negligible.
- Overall system slower than fast sample and hold
- $R1, C_C$ : additional compensation
- Use LF156 for
  - Fast settling time
  - Low  $V_{OS}$

Typical Applications (Continued)

High Q Band Pass Filter

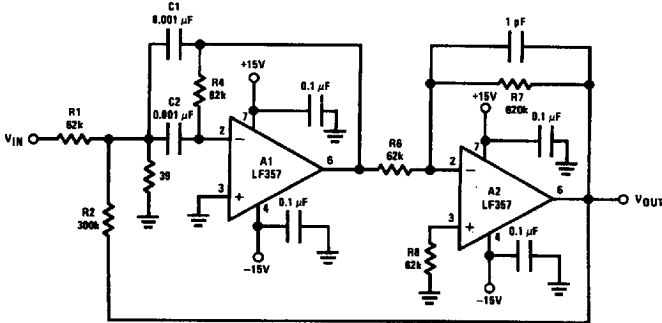

TL/H/5646-28

- By adding positive feedback (R2) Q increases to 40
- $f_{BP} = 100 \text{ kHz}$

$$\frac{V_{OUT}}{V_{IN}} = 10\sqrt{Q}$$

- Clean layout recommended
- Response to a 1 Vp-p tone burst: 300  $\mu\text{s}$

High Q Notch Filter

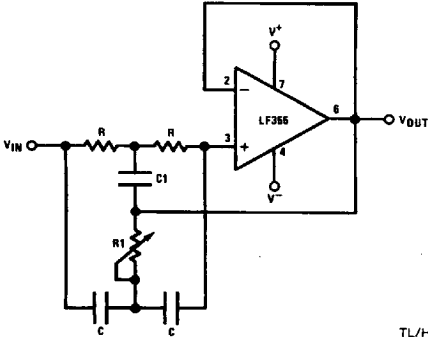

TL/H/5646-34

- $2R1 = R = 10 \text{ M}\Omega$
- $2C = C1 = 300 \text{ pF}$
- Capacitors should be matched to obtain high Q
- $f_{NOTCH} = 120 \text{ Hz}$ , notch = -55 dB,  $Q > 100$
- Use LF155 for
  - Low  $I_B$
  - Low supply current