

2SK3402

■ Features

- Low on-resistance
 $R_{DS(on)1} = 15 \text{ m}\Omega \text{ MAX. (} V_{GS} = 10 \text{ V, } I_D = 18 \text{ A)}$
 $R_{DS(on)2} = 22 \text{ m}\Omega \text{ MAX. (} V_{GS} = 4.0 \text{ V, } I_D = 18 \text{ A)}$
- Low C_{iss} : $C_{iss} = 3200 \text{ pF TYP.}$
- Built-in gate protection diode

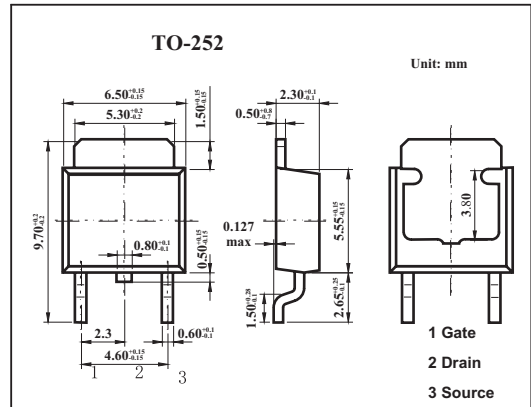

■ Absolute Maximum Ratings $T_a = 25^\circ\text{C}$

Parameter	Symbol	Rating	Unit
Drain to source voltage	V_{DSS}	60	V
Gate to source voltage	V_{GSS}	± 20	V
Drain current	I_D	± 36	A
	I_{dp}^*	± 144	A
Power dissipation	P_D	$T_c=25^\circ\text{C}$	40
		$T_a=25^\circ\text{C}$	1.0
Channel temperature	T_{ch}	150	$^\circ\text{C}$
Storage temperature	T_{stg}	-55 to +150	$^\circ\text{C}$

* $PW \leq 10 \mu\text{s}$, Duty Cycle $\leq 1\%$

■ Electrical Characteristics $T_a = 25^\circ\text{C}$

Parameter	Symbol	Testconditions	Min	Typ	Max	Unit
Drain cut-off current	I_{DSS}	$V_{DS}=60\text{V}, V_{GS}=0$			10	μA
Gate leakage current	I_{GSS}	$V_{GS}=\pm 20\text{V}, V_{DS}=0$			± 10	μA
Gate cutoff voltage	$V_{GS(off)}$	$V_{DS}=10\text{V}, I_D=1\text{mA}$	1.5	2.0	2.5	V
Forward transfer admittance	$ Y_{fs} $	$V_{DS}=10\text{V}, I_D=18\text{A}$	13	27		S
Drain to source on-state resistance	$R_{DS(on)1}$	$V_{GS}=10\text{V}, I_D=18\text{A}$		12	15	$\text{m}\Omega$
	$R_{DS(on)2}$	$V_{GS}=4.0\text{V}, I_D=18\text{A}$		15	22	$\text{m}\Omega$
Input capacitance	C_{iss}	$V_{DS}=10\text{V}, V_{GS}=0, f=1\text{MHz}$		3200		pF
Output capacitance	C_{oss}				520	pF
Reverse transfer capacitance	C_{rss}			270		pF
Turn-on delay time	t_{on}	$I_D=18\text{A}, V_{GS(on)}=10\text{V}, R_G=10\Omega, V_{DD}=30\text{V}$		36		ns
Rise time	t_r			310		ns
Turn-off delay time	t_{off}			170		ns
Fall time	t_f			180		ns
Total Gate Charge	Q_G	$I_D=36\text{A}, V_{DD}=48\text{V}, V_{GS}=10\text{V}$		61		nC
Gate to Source Charge	Q_{GS}			8.2		nC
Gate to Drain Charge	Q_{GD}			17		nC