

## Applications

- CATV Broadcast Networks
- Networks with Limited Fiber
- Architectures Using Separate Optical Wavelengths to Carry Targeted Services

## Features

- Standard ITU Grid Wavelengths
- Advanced Analog Chip Design
- Reduced Equipment Requirements in the Hub
- OC-48 Pin Out
- Telcordia Technologies™ 468 Compliant
- Wide Temperature Range – Stable Even in Harsh Environments
- RoHS Compliant

The 1754C laser module is a Dense Wavelength Division Multiplexing (DWDM) laser for analog CATV applications. It features a distributed-feedback (DFB) device that has been designed specifically for radio frequency (RF) and CATV applications. The 1754C laser module has a wide temperature range for reliable performance in harsh node environments and narrow transmitter designs. It also features low adiabatic chirp to maximize signal quality in short and long lengths of fiber. The laser's excellent inherent linearity minimizes degradation of the broadcast signals caused by quadrature amplitude modulated (QAM) channels.

The 1754C is available in all C-band ITU grid wavelengths.

## Performance Highlights

	Min	Typical	Max	Units
Available Wavelengths	See page 3			nm
Operating Temperature Range	-40	25	+85	°C
Optical Output Power	6 - 16	-	-	mW
Adiabatic Chirp (measured at 500 MHz)	40	-	100	MHz/mA
Composite Second-Order Distortion (CSO)	-	-	-55	dBc
Composite Triple Beat Distortion (CTB)	-	-	-64	dBc
Carrier-to-Noise Ratio (CNR)	52	-	-	dB
Frequency Range	5	-	2700	MHz
RF Return Loss	16	-	-	dB

Noise and distortion performance above assume 79 channel NTSC loading with no QAM, 0 dBm received optical power. See following pages for complete specifications and operating/test conditions.

## Absolute Maximum Ratings

Stresses in excess of the absolute maximum ratings can cause permanent damage to the device. These are absolute stress ratings only. Functional operation of the device is not implied at these or any other conditions in excess of those given in the operational sections of the data sheet. Exposure to absolute maximum ratings for extended periods can adversely affect device reliability.

Parameter	Symbol	Condition	Min	Max	Unit
Operating Temperature Range	$T_C$	Continuous	-40	+85	°C
Storage Temperature Range	$T_{STG}$	Continuous	-40	+85	°C
Average RF Input Power	-	60 seconds	-	62	dBmV
Laser Forward DC Current	-	Continuous	-	150	mA
Photodiode Reverse Voltage	$V_{MPD}$	Continuous	-	10	V
Laser Reverse Voltage, DC	-	Continuous	-	1	V
ESD	-	HBM: R = 1500 Ohm, C = 100pF	-500	500	V
TEC Current	$I_{TEC}$	Continuous	-1.5	1.5	A

## Electrical/Optical Characteristics

Laser Temperature (TL) = 25°C,  $I_F = I_{OP}$ , Beginning of Life (BOL)

Parameter	Symbol	Condition	Min	Typ	Max	Unit
Operating Case Temperature	$T_C$	-	-40	25	+85	°C
Optical Output Power	$P_O$	6 mW version* 8 mW version* 10 mW version 16 mW version	6 8 10 16	- - - -	7.9 9.9 15.9 19.9	mW
Threshold Current	$I_{TH}$	25°C, BOL	-	-	20	mA
Slope Efficiency	$\eta$		.07	-	-	W/A
Operating Current	$I_{OP}$	BOL	-	-	120	mA
Operating Voltage	$V_{OP}$	25°C, BOL	-	-	2.5	V
Wavelength	$\lambda$	ITU Grid	See page 3			nm
$\lambda$ Drift over $T_C$ Range	$\Delta\lambda_{OP}$	$I_F = 60$ mA, $T = T_{OP}$	-	-	40	pm
Laser Adiabatic Chirp	FM	$I_F = 60$ mA, $T_{OP} = 25^\circ\text{C}$ @ 500 MHz	40	-	100	MHz/mA
Optical Return Loss	ORL	-	40	-	-	dB
Sidemode Suppression Ratio	SMSR		30	-	-	dB
Optical Isolation	ISO	25°C	30	-	-	dB
Relative Intensity Noise	RIN	$I_F = I_{TH} + 70$ mA		-	-155	dB/Hz
Nominal Input Impedance	$Z_{IN}$	-	22	25	27	$\Omega$
MPD Responsivity	$r_{PD}$	$V_{RM} = 5$ V	10	-	200	$\mu\text{A/mW}$
MPD Dark Current	$I_D$	$I_{OP} = 0$ mA $V_{RM} = 5$ V, $T_{OP} = 25^\circ\text{C}$			0.2	$\mu\text{A}$
MPD Current Relative to Output Power	-	$V_{RM} = 5$ V, $T_{OP} = 25^\circ\text{C}$	10	-	200	mA/W
Thermistor Resistance	$R_{TH}$	$T_{OP} = 25^\circ\text{C}$	9.5	10	10.5	k $\Omega$
Thermistor Temp. Coefficient	$TC_{TH}$	$T_{OP} = 25^\circ\text{C}$	-	-4.4	-	% / °C
TEC Voltage	$V_{TEC}$	-	-2.5	-	3.8	V

\*For 6 and 8 mW option, lossy splice may be applied.

## RF Characteristic

Laser Temperature (TL) = 25°C, I<sub>F</sub>=I<sub>OP</sub>, Beginning of Life (BOL)

Parameter	Symbol	Condition	Min	Typ	Max	Units
Carrier-to-Noise Ratio <sup>(1)</sup>	CNR	79 NTSC, 3.3% OMI 1 m fiber min, 4.2 MHz NBW	52	-	-	dB
Composite Second-Order <sup>(1)</sup>	CSO	79 NTSC, 3.3% OMI 1 m fiber min			-55	dBm
Composite Triple Beat <sup>(1)</sup>	CTB	79 NTSC, 3.3% OMI 1 m fiber min	-		-64	dBc
Frequency Response Flatness	S21	40 MHz to 890 MHz I <sub>F</sub> = 60 mA, T <sub>OP</sub> = 25°C	-	-	1	dB <sub>p-p</sub>
		5 MHz to 2700 MHz I <sub>F</sub> = 60 mA, T <sub>OP</sub> = 25°C			4	dB <sub>p-p</sub>
RF Return Loss resistive match 50Ω to 25Ω pad	S11	5 MHz to 2700 MHz I <sub>F</sub> = 60 mA, T <sub>OP</sub> = 25°C	16	-	-	dB
Carrier-to-Noise Ratio <sup>(2)</sup>	CNR	Channel Loading: Frequencies set at 7, 13, 19, 25, 31, and 37 MHz	51	-	-	dB
Composite Second-Order <sup>(2)</sup>	CSO	Receiver thermal noise 8 pA*Hz <sup>-0.5</sup> Photodiode responsivity ~1.1 A/W	-	-	-50	dBm
Composite Triple Beat <sup>(2)</sup>	CTB	Noise Bandwidth 4.2 MHz	-	-	-60	dBc

(1). Broadband Forward Path

(2). Return Path. Guaranteed by design, not to test in production.

In order to prevent reflection-induced distortion, the laser must be connected to an optical cable having a return loss of at least 55 dB for discrete reflections and 30 dB for distributed reflections.

## ITU Grid Channel Numbering

Channel	Wavelength (nm)	Channel	Wavelength (nm)	Channel	Wavelength (nm)
64	1526.44	47	1539.77	30	1553.33
63	1529.22	46	1540.56	29	1554.13
62	1527.99	45	1541.35	28	1554.94
61	1528.77	44	1542.14	27	1555.75
60	1529.55	43	1542.94	26	1556.56
59	1530.33	42	1543.73	25	1557.36
58	1531.12	41	1544.53	24	1558.17
57	1531.90	40	1545.32	23	1558.98
56	1532.68	39	1546.12	22	1559.79
55	1533.47	38	1546.92	21	1560.61
54	1534.25	37	1547.72	20	1561.42
53	1535.04	36	1548.51	19	1562.23
52	1535.82	35	1549.32	18	1563.05
51	1536.61	34	1550.12		
50	1537.40	33	1550.92		
49	1538.19	32	1551.72		
48	1538.98	31	1552.52		

## Electrical Schematics

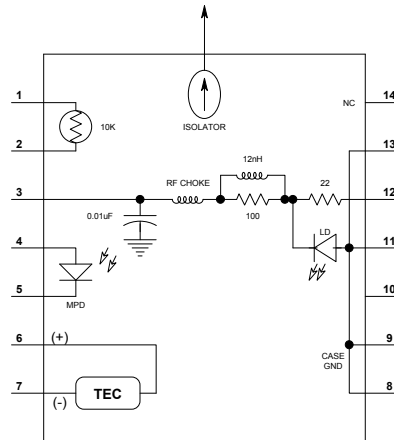

Figure 1. 1754C Laser Simplified Schematic

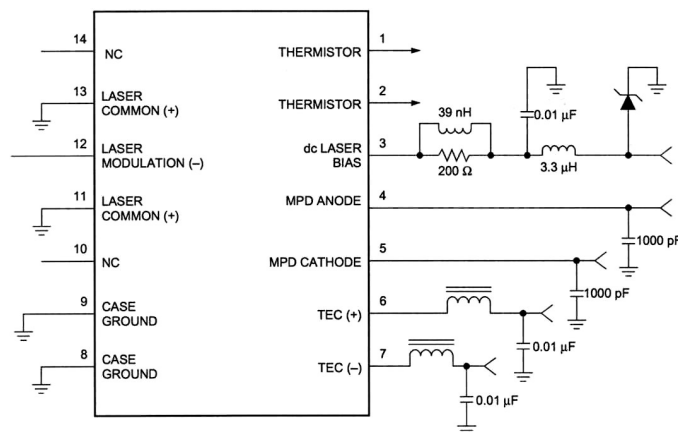
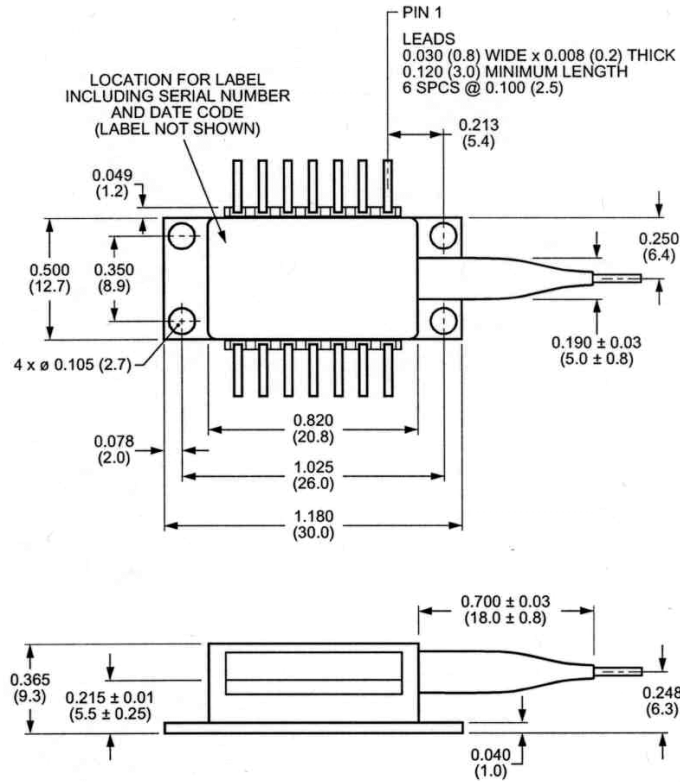

Figure 2. 1754C Circuit Schematic

## Pin Definitions

Pin	Description
1	Thermistor
2	Thermistor
3	DC Laser Bias (-)
4	MPD Anode (-)
5	MPD Cathode (+)
6	Thermal Electric Cooler (+)
7	Thermal Electric Cooler (-)
8	Case Ground
9	Case Ground
10	NC
11	Laser Common (+), Case GND
12	Laser Modulation (-)
13	Laser Common (+), Case GND
14	NC

## Outline Diagram (Dimensions are in inches and millimeters)



Fiber type: 0.9 mm O.D. jacketed single mode 9/125 mm (SMF-28)  
 Fiber length: 130 cm + 10 cm, measured as shown below  
 Nominal pin lead length: 0.2 inch (from external package wall)

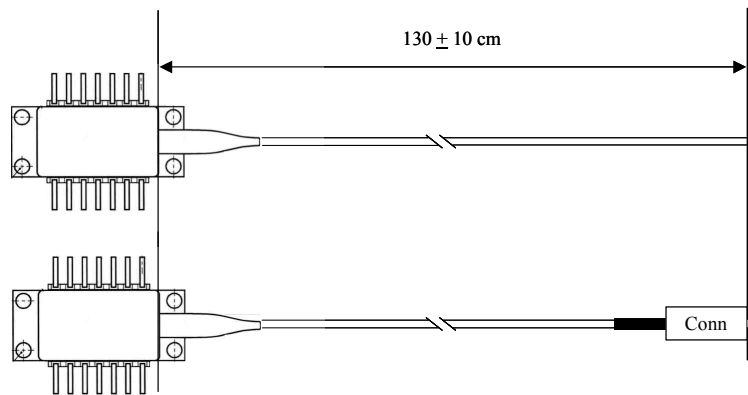

## Laser Safety

This product meets the appropriate standard in Title 21 of the Code of Federal Regulations (CFR). FDA/CDRH Class 1 laser product. This device has been classified with the FDA/CDRH under accession number 0220309.

All Versions of this laser are Class 1 laser product, tested according to IEC 60825-1:2007/EN 60825-1:2007

Single-mode fiber pigtail with SC/APC connectors (standard).

Wavelength = 1.5  $\mu\text{m}$ .

Maximum power = 30 mW.

Because of size constraints, laser safety labeling (including an FDA class 1 label) is not affixed to the module, but attached to the outside of the shipping carton.

Product is not shipped with power supply.

**Caution: Use of controls, adjustments and procedures other than those specified herein may result in hazardous laser radiation exposure.**

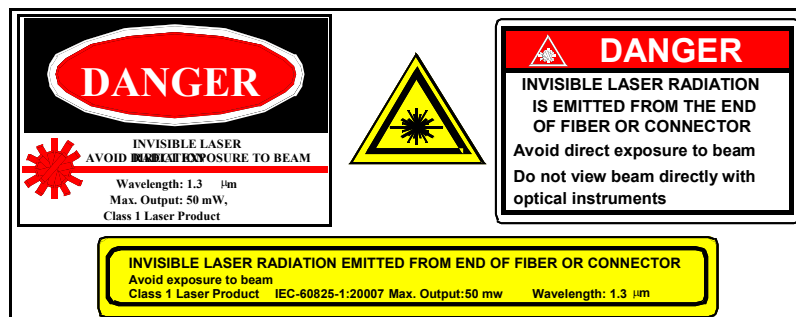

## Ordering Code Definitions

1754C – ww – xx – yy – zz

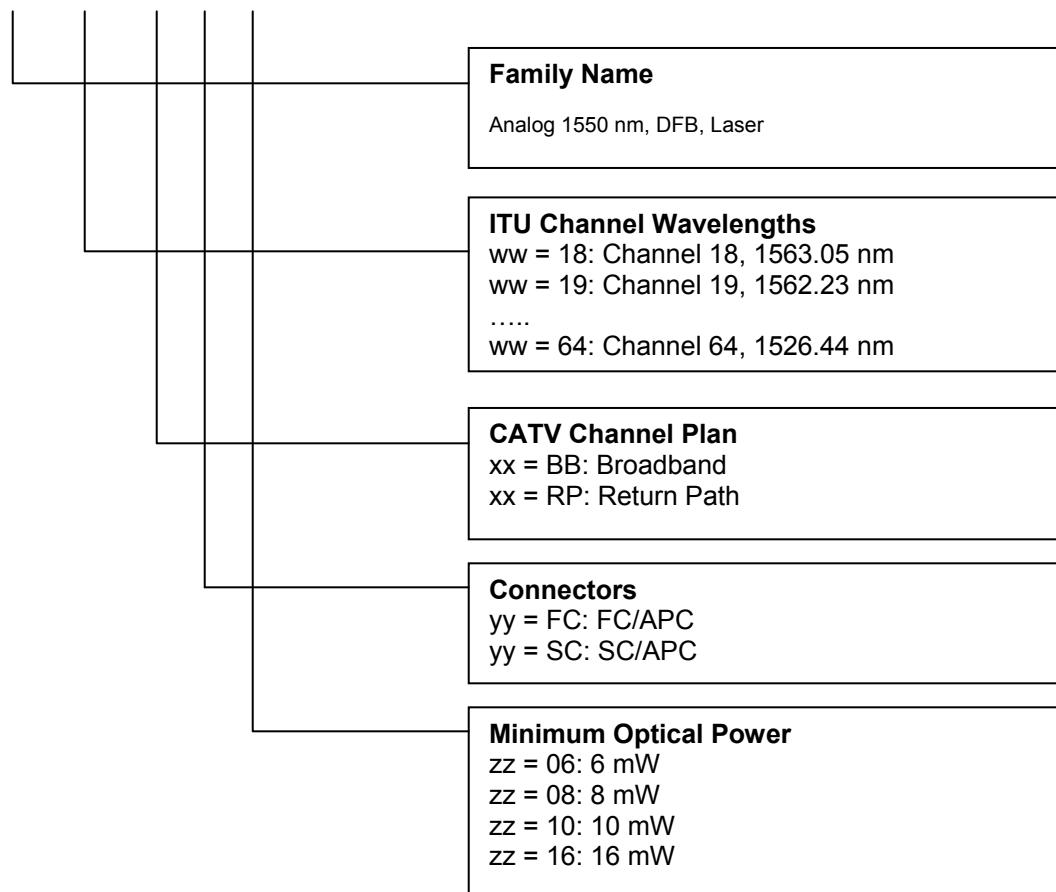

## Example

**1754C-32-BB-SC-08:** 1754C, ITU channel 32, 1551.72 nm, SC/APC connector, 8 mW minimum optical power.