

AS5145H/AS5145A/AS5145B

12-Bit Programmable Magnetic Rotary Encoder

1 General Description

The AS5145 is a contact less magnetic rotary encoder for accurate angular measurement over a full turn of 360 degrees.

It is a system-on-chip, combining integrated Hall elements, analog front end and digital signal processing in a single device.

To measure the angle, only a simple two-pole magnet, rotating over the center of the chip, is required. The magnet can be placed above or below the IC.

The absolute angle measurement provides instant indication of the magnet's angular position with a resolution of $0.0879^\circ = 4096$ positions per revolution. This digital data is available as a serial bit stream and as a PWM signal.

An internal voltage regulator allows the AS5145 to operate at either 3.3V or 5V supplies.

2 Key Features

- Contact less high resolution rotational position encoding over a full turn of 360 degrees
- Two digital 12-bit absolute outputs:
 - Serial interface
 - Pulse width modulated (PWM) output

- Three incremental outputs
- Quadrature A/B/I (10 or 12 bit) and Index output signal (pre-programmed versions available AS5145A for 10-bit and AS5145B for 12-bit)
- User programmable zero position
- Failure detection mode for magnet placement, monitoring, and loss of power supply
- Red-Yellow-Green indicators display placement of magnet in Z-axis
- Serial read-out of multiple interconnected AS5145 devices using Daisy Chain mode
- Tolerant to magnet misalignment and gap variations
- Wide temperature range: - 40°C to +150°C
- Fully automotive qualified to AEC-Q100, grade 0
- Small Pb-free package: SSOP 16 (5.3mm x 6.2mm)

3 Applications

The device is ideal for industrial applications like contactless rotary position sensing and robotics; automotive applications like steering wheel position sensing, transmission gearbox encoder, head light position control, torque sensing, valve position sensing and replacement of high end potentiometers.

Figure 1. AS5145 Automotive Rotary Encoder IC

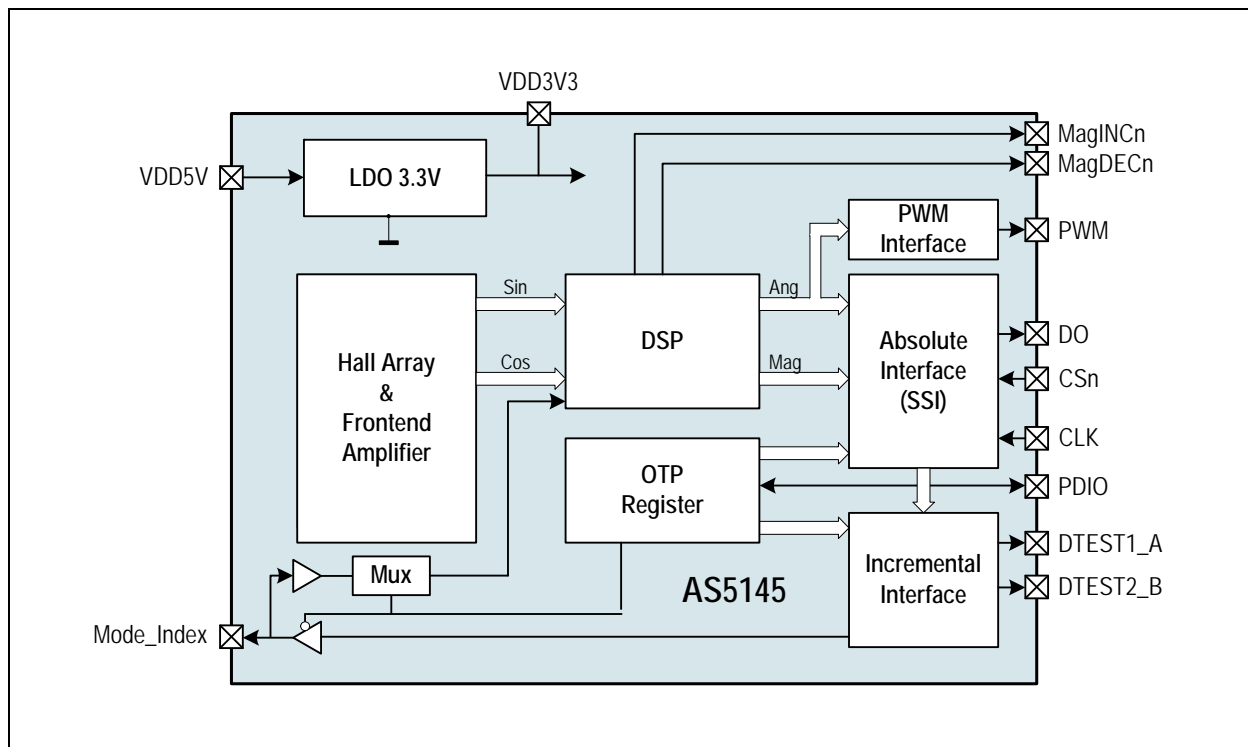



Contents

1	General Description	1
2	Key Features.....	1
3	Applications.....	1
4	Pin Assignments	4
4.1	Pin Descriptions.....	4
5	Absolute Maximum Ratings	6
6	Electrical Characteristics.....	7
6.1	Magnetic Input Specification.....	8
6.2	System Specifications	9
7	Timing Characteristics	11
8	Detailed Description.....	12
8.1	Mode_Index Pin.....	12
8.1.1	Synchronous Serial Interface (SSI)	13
8.1.2	Incremental Mode	14
8.1.3	Sync Mode.....	16
8.1.4	Sin/Cosine Mode	16
8.1.5	Daisy Chain Mode	16
8.2	Pulse Width Modulation (PWM) Output.....	17
8.2.1	Changing the PWM Frequency.....	18
8.3	Analog Output.....	18
9	Application Information	19
9.1	Programming the AS5145	19
9.1.1	Zero Position Programming	19
9.1.2	OTP Memory Assignment.....	20
9.1.3	User Selectable Settings	20
9.1.4	OTP Default Setting.....	21
9.1.5	Redundancy.....	21
9.1.6	Redundant Programming Option	22
9.1.7	OTP Register Entry and Exit Condition	22
9.2	Alignment Mode.....	23
9.3	3.3V / 5V Operation	24
9.4	Selecting Proper Magnet.....	24
9.4.1	Physical Placement of the Magnet	25
9.4.2	Magnet Placement.....	26
9.5	Failure Diagnostics	26
9.5.1	Magnetic Field Strength Diagnosis	26
9.5.2	Power Supply Failure Detection	26
9.6	Angular Output Tolerances.....	26
9.6.1	Accuracy	26
9.6.2	Transition Noise.....	28
9.6.3	High Speed Operation	28
9.6.4	Propagation Delays	28
9.6.5	Internal Timing Tolerance	29
9.6.6	Temperature	29
9.6.7	Accuracy over Temperature	29



9.7 Differences between AS5145H, AS5145A, AS5145B and AS5145I	29
10 Package Drawings and Markings	30
10.1 Recommended PCB Footprint.....	32
11 Ordering Information	35



4 Pin Assignments

Figure 2. Pin Assignments (Top View)

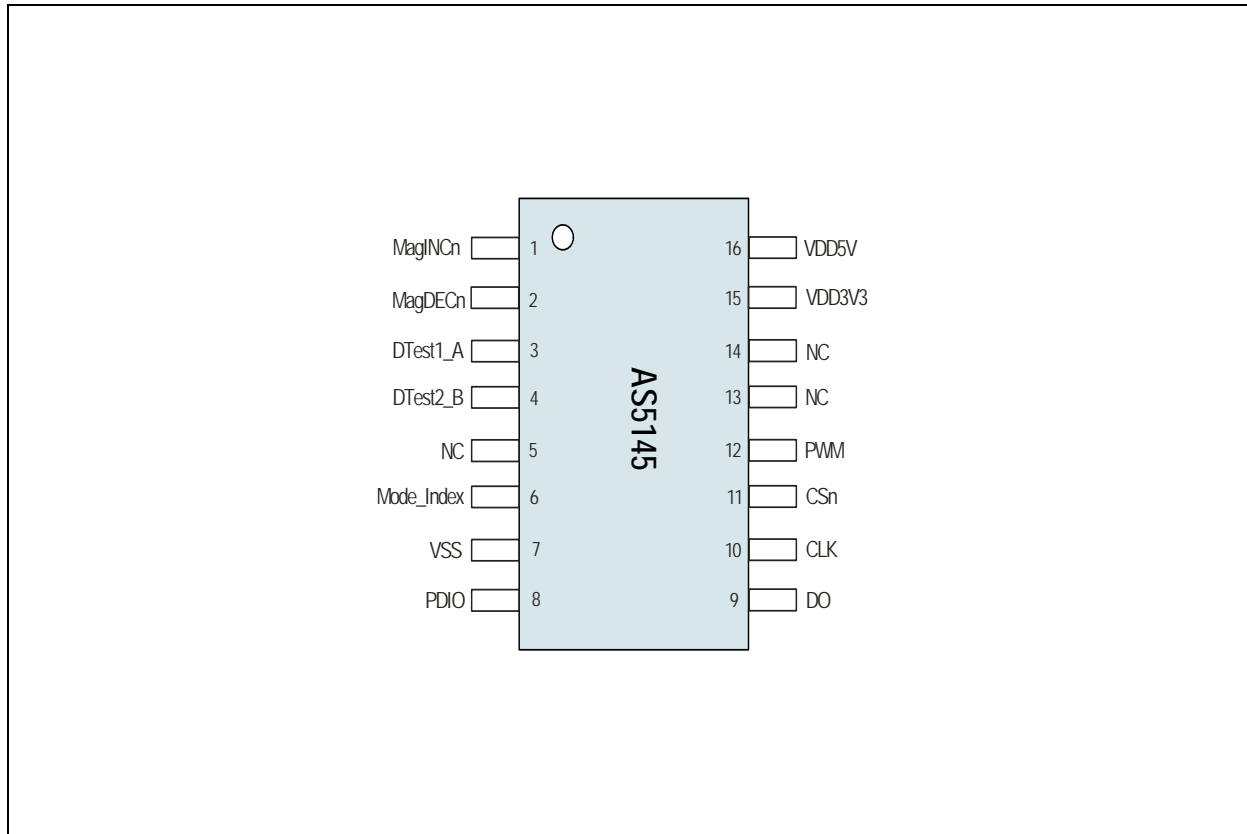

4.1 Pin Descriptions

The following SSOP16 shows the description of each pin of the standard SSOP16 package (Shrink Small Outline Package, 16 leads, body size: 5.3mm x 6.2mm); (see Figure 2).

Table 1. Pin Descriptions

Pin Name	Pin Number	Pin Type	Description
MagINCn	1	Digital output open drain	Magnet Field Magnitude Increase. Active low. Indicates a distance reduction between the magnet and the device surface. (see Table 9)
MagDECn	2		Magnet Field Magnitude Decrease. Active low. Indicates a distance increase between the device and the magnet. (see Table 9)
DTest1_A	3	Digital output	Test output in default mode
DTest2_B	4		Test output in default mode
NC	5	-	Must be left unconnected
Mode_Index	6	Digital input/output pull-down	Select between slow (open, low: VSS) and fast (high) mode. Internal pull-down resistor (10kΩ).
VSS	7	Supply pin	Negative Supply Voltage (GND)
PDIO	8	Digital input pull-down	OTP Programming Input and Data Input for Daisy Chain mode. Pin has an internal pull-down resistor (74kΩ). Connect this pin to VSS if programming is not required.
DO	9	Digital output/ tri-state	Data Output of Synchronous Serial Interface



Table 1. Pin Descriptions

Pin Name	Pin Number	Pin Type	Description
CLK	10	Digital input, Schmitt-Trigger input	Clock Input of Synchronous Serial Interface; Schmitt-Trigger input
CSn	11	Digital input pull-down, Schmitt-Trigger input	Chip Select . Active low. Schmitt-Trigger input, internal pull-up resistor (50kΩ)
PWM	12	Digital output	Pulse Width Modulation
NC	13	-	Must be left unconnected
NC	14	-	Must be left unconnected
VDD3V3	15	Supply pin	3V-Regulator Output, internally regulated from VDD5V. Connect to VDD5V for 3V supply voltage. Do not load externally.
VDD5V	16	Supply pin	Positive Supply Voltage, 3.0V to 5.5V

Pin 1 and 2 are the magnetic field change indicators, MagINCn and MagDECn (magnetic field strength increase or decrease through variation of the distance between the magnet and the device). These outputs can be used to detect the valid magnetic field range. Furthermore those indicators can also be used for contact-less push-button functionality.

Pin 3 and 4 are multi function pins for sync mode, sin/cosine mode and incremental mode.

Pin 6 Mode_Index allows switching between filtered (slow) and unfiltered (fast mode). In incremental mode, the pin changes from input to output and provides the index pulse information. A change of the Mode during operation is not allowed. The setup must be constant during power up and during operation.

Pins 7, 15, and 16 are supply pins, pins 5, 13, and 14 are for internal use and must not be connected.

Pin 8 (PDIO) is used to program the zero-position into the OTP(see page 19). This pin is also used as digital input to shift serial data through the device in Daisy Chain configuration, (see page 14).

Pin 11 Chip Select (CSn; active low) selects a device within a network of AS5145 encoders and initiates serial data transfer. A logic high at CSn puts the data output pin (DO) to tri-state and terminates serial data transfer. This pin is also used for alignment mode (see Alignment Mode on page 23) and programming mode (see Programming the AS5145 on page 19).

Pin 12 allows a single wire output of the 12-bit absolute position value. The value is encoded into a pulse width modulated signal with 1μs pulse width per step (1μs to 4096μs over a full turn). By using an external low pass filter, the digital PWM signal is converted into an analog voltage, e.g. for making a direct replacement of potentiometers possible.



5 Absolute Maximum Ratings

Stresses beyond those listed in [Table 2](#) may cause permanent damage to the device. These are stress ratings only, and functional operation of the device at these or any other conditions beyond those indicated in [Section 6 Electrical Characteristics on page 7](#) is not implied. Exposure to absolute maximum rating conditions for extended periods may affect device reliability.

Table 2. Absolute Maximum Ratings

Parameter	Min	Max	Units	Comments
Electrical Parameters				
DC supply voltage at pin VDD5V	-0.3	7	V	
DC supply voltage at pin VDD3V3		5	V	
Input pin voltage	-0.3	VDD5V +0.3	V	Except VDD3V3
Input current (latchup immunity)	-100	100	mA	Norm: EIA/JESD78 Class II Level A
Electrostatic Discharge				
Electrostatic discharge		± 2	kV	Norm: JESD22-A114E
Temperature Ranges and Storage Conditions				
Storage temperature	-55	150	°C	Min -67°F; Max +302°F
Package Body temperature		260	°C	The reflow peak soldering temperature (body temperature) specified is in accordance with <i>IPC/JEDEC J-STD-020 "Moisture/Reflow Sensitivity Classification for Non-Hermetic Solid State Surface Mount Devices"</i> . The lead finish for Pb-free leaded packages is matte tin (100% Sn).
Humidity non-condensing	5	85	%	
Moisture Sensitive Level (MSL)		3		Represents a maximum floor time of 168h



6 Electrical Characteristics

$T_{AMB} = -40$ to $+150^{\circ}\text{C}$, $V_{DD5V} = 3.0\text{-}3.6\text{V}$ (3V operation) $V_{DD5V} = 4.5\text{-}5.5\text{V}$ (5V operation) unless otherwise noted. Also valid for version I.

Table 3. Electrical Characteristics

Symbol	Parameter	Condition	Min	Typ	Max	Unit
Operating Conditions						
T_{AMB}	Ambient temperature	Version H/A/B	-40		+150	$^{\circ}\text{C}$
I_{supp}	Supply current			16	21	mA
V_{DD5V}	Supply voltage at pin V_{DD5V}	5V Operation	4.5	5.0	5.5	V
V_{DD3V3}	Voltage regulator output voltage at pin V_{DD3V3}		3.0	3.3	3.6	
V_{DD5V}	Supply voltage at pin V_{DD5V}	3.3V Operation (pin V_{DD5V} and V_{DD3V3} connected)	3.0	3.3	3.6	V
V_{DD3V3}	Supply voltage at pin V_{DD3V3}		3.0	3.3	3.6	
V_{ON}	Power-on reset thresholds On voltage; 300mV typ. hysteresis	DC supply voltage 3.3V (V_{DD3V3})	1.37	2.2	2.9	V
V_{off}	Power-on reset thresholds Off voltage; 300mV typ. hysteresis		1.08	1.9	2.6	
Programming Conditions						
V_{PROG}	Programming voltage	Voltage applied during programming	3.3		3.6	V
$V_{ProgOff}$	Programming voltage off level	Line must be discharged to this level	0		1	V
I_{PROG}	Programming current	Current during programming			100	mA
$R_{programmed}$	Programmed fuse resistance (log 1)	10 μA max. current @ 100mV	100k		∞	Ω
$R_{unprogrammed}$	Unprogrammed fuse resistance (log 0)	2mA max. current @ 100mV	50		100	Ω
DC Characteristics CMOS Schmitt-Trigger Inputs: CLK, CSn (CSn = Internal Pull-up)						
V_{IH}	High level input voltage	Normal operation	0.7 * V_{DD5V}			V
V_{IL}	Low level input voltage				0.3 * V_{DD5V}	V
V_{IOn} , V_{Ioff}	Schmitt Trigger hysteresis		1			V
I_{LEAK}	Input leakage current	CLK only	-1		1	μA
I_{iL}	Pull-up low level input current	CSn only, V_{DD5V} : 5.0V	-30		-100	
DC Characteristics CMOS / Program Input: PDIO						
V_{IH}	High level input voltage		0.7 * V_{DD5V}		V_{DD5V}	V
V_{PROG}^1	High level input voltage	During programming	3.3		3.6	V
V_{IL}	Low level input voltage				0.3 * V_{DD5V}	V
I_{iL}	High level input current	V_{DD5V} : 5.5V	30		100	μA
DC Characteristics CMOS Output Open Drain: MagINCn, MagDECn						
I_{OZ}	Open drain leakage current				1	μA
V_{OL}	Low level output voltage				$V_{SS} + 0.4$	V



Table 3. Electrical Characteristics

Symbol	Parameter	Condition	Min	Typ	Max	Unit
I _O	Output current	V _{DD5V} : 4.5V			4	mA
		V _{DD5V} : 3V			2	
DC Characteristics CMOS Output: PWM						
V _{OH}	High level output voltage		V _{DD5V} - 0.5			V
V _{OL}	Low level output voltage				V _{SS} + 0.4	V
I _O	Output current	V _{DD5V} : 4.5V			4	mA
		V _{DD5V} : 3V			2	
DC Characteristics CMOS Output: A, B, Index						
V _{OH}	High level output voltage		V _{DD5V} - 0.5			V
V _{OL}	Low level output voltage				V _{SS} + 0.4	V
I _O	Output current	V _{DD5V} : 4.5V			4	mA
		V _{DD5V} : 3V			2	
DC Characteristics Tri-state CMOS Output: DO						
V _{OH}	High level output voltage		V _{DD5V} - 0.5			V
V _{OL}	Low level output voltage				V _{SS} + 0.4	V
I _O	Output current	V _{DD5V} : 4.5V			4	mA
		V _{DD5V} : 3V			2	
I _{OZ}	Tri-state leakage current				1	μA

1. Either with 3.3V or 5V supply.

6.1 Magnetic Input Specification

T_{AMB} = -40 to +150°C, V_{DD5V} = 3.0 to 3.6V (3V operation) V_{DD5V} = 4.5 to 5.5V (5V operation) unless otherwise noted. Also valid for version I.

Two-pole cylindrical diametrically magnetized source:

Table 4. Magnetic Input Specification

Symbol	Parameter	Condition	Min	Typ	Max	Unit
d _{mag}	Diameter	Recommended magnet: Ø 6mm x 2.5mm for cylindrical magnets	4	6		mm
t _{mag}	Thickness		2.5			mm
B _{pk}	Magnetic input field amplitude	Required vertical component of the magnetic field strength on the die's surface, measured along a concentric circle with a radius of 1.1mm	45		75	mT
B _{off}	Magnetic offset	Constant magnetic stray field			± 10	mT
	Field non-linearity	Including offset gradient			5	%
f _{mag_abs}	Input frequency (rotational speed of magnet)	153 rpm @ 4096 positions/rev; fast mode			2.54	Hz
		38 rpm @ 4096 positions/rev; slow mode			0.63	



Table 4. Magnetic Input Specification

Symbol	Parameter	Condition	Min	Typ	Max	Unit
Disp	Displacement radius	Max. offset between defined device center and magnet axis (see Figure 19)			0.25	mm
Ecc	Eccentricity	Eccentricity of magnet center to rotational axis			100	μm
	Recommended magnet material and temperature drift	NdFeB (Neodymium Iron Boron)		-0.12		%K
		SmCo (Samarium Cobalt)		-0.035		

6.2 System Specifications

$T_{AMB} = -40$ to $+150^{\circ}\text{C}$, $V_{DD5V} = 3.0$ to 3.6V (3V operation) $V_{DD5V} = 4.5$ to 5.5V (5V operation) unless otherwise noted. Also valid for version I.

Table 5. Input Specification

Symbol	Parameter	Condition	Min	Typ	Max	Unit
RES	Resolution	0.088 deg			12	bit
INL _{opt}	Integral non-linearity (optimum)	Maximum error with respect to the best line fit. Centered magnet without calibration, $T_{AMB} = 25^{\circ}\text{C}$.			± 0.5	deg
INL _{temp}	Integral non-linearity (optimum)	Maximum error with respect to the best line fit. Centered magnet without calibration, $T_{AMB} = -40$ to $+150^{\circ}\text{C}$			± 0.9	deg
INL	Integral non-linearity	Best line fit = $(Err_{max} - Err_{min}) / 2$ Over displacement tolerance with 6mm diameter magnet, without calibration, $T_{AMB} = -40$ to $+150^{\circ}\text{C}$			± 1.4	deg
DNL	Differential non-linearity	12-bit, no missing codes			± 0.044	deg
TN	Transition noise	1 sigma, fast mode (MODE = 1)			0.06	Deg RMS
		1 sigma, slow mode (MODE = 0 or open)			0.03	
t _{PwrUp}	Power-up time	Fast mode (Mode = 1); Until status bit OCF = 1			20	ms
		Slow mode (Mode = 0 or open); Until OCF = 1			80	
t _{delay}	System propagation delay absolute output : delay of ADC, DSP and absolute interface	Fast mode (MODE = 1)			96	μs
		Slow mode (MODE = 0 or open)			384	
t _{delayINC}	System propagation delay incremental output AS5145A and AS5145B: delay of ADC, DSP and incremental interface	Only fast mode possible			192	μs
f _s	Internal sampling rate for absolute output:	$T_{AMB} = 25^{\circ}\text{C}$, slow mode (MODE=0 or open)	2.48	2.61	2.74	kHz
		$T_{AMB} = -40$ to $+150^{\circ}\text{C}$, slow mode (MODE=0 or open)	2.35	2.61	2.87	
f _s	Internal sampling rate for absolute output	$T_{AMB} = 25^{\circ}\text{C}$, fast mode (MODE = 1)	9.90	10.42	10.94	kHz
		$T_{AMB} = -40$ to $+150^{\circ}\text{C}$, fast mode (MODE=1)	9.38	10.42	11.46	
CLK/SEL	Read-out frequency	Max. clock frequency to read out serial data			1	MHz



Figure 3. Integral and Differential Non-Linearity Example

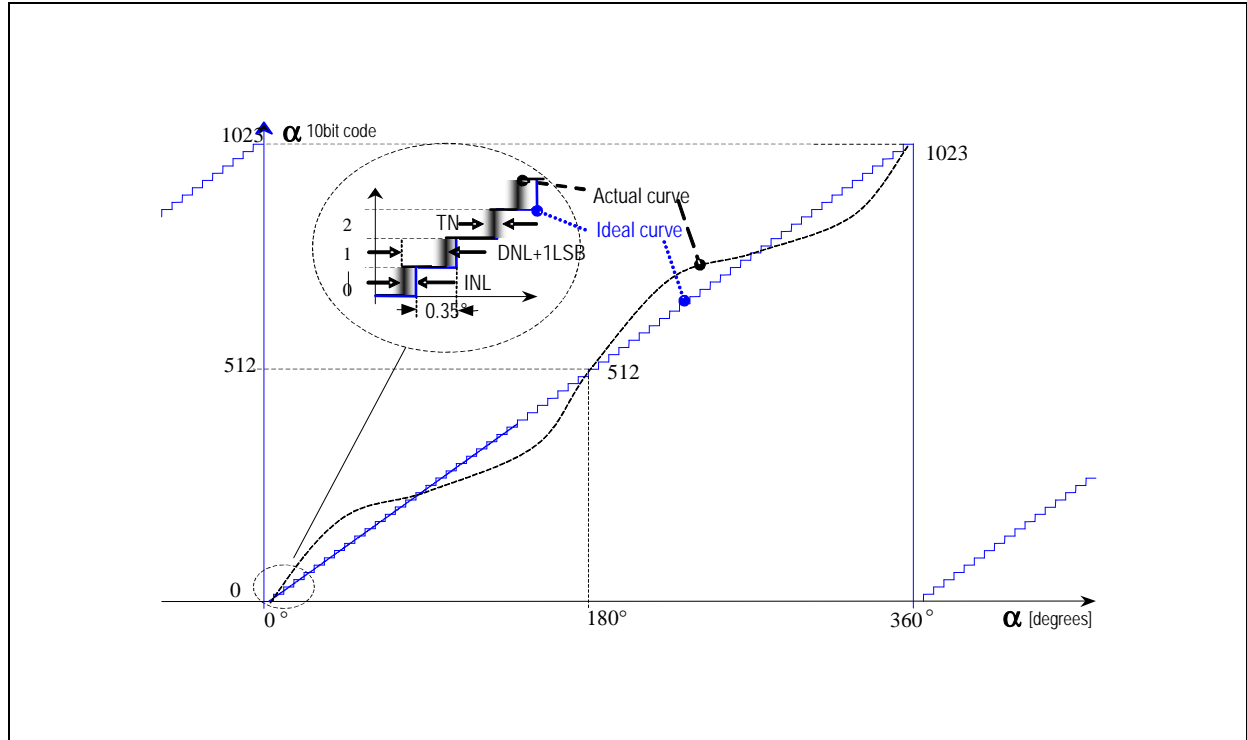

Integral Non-Linearity (INL) is the maximum deviation between actual position and indicated position.

Differential Non-Linearity (DNL) is the maximum deviation of the step length from one position to the next.

Transition Noise (TN) is the repeatability of an indicated position.



7 Timing Characteristics

$T_{AMB} = -40$ to $+150$ °C, $V_{DD5V} = 3.0$ to $3.6V$ (3V operation) $V_{DD5V} = 4.5$ to $5.5V$ (5V operation), unless otherwise noted. Also valid for version I.

Table 6. Timing Characteristics

Symbol	Parameter	Conditions	Min	Typ	Max	Units
Synchronous Serial Interface (SSI)						
$t_{DOactive}$	Data output activated (logic high)	Time between falling edge of CSn and data output activated			100	ns
t_{CLKFE}	First data shifted to output register	Time between falling edge of CSn and first falling edge of CLK	500			ns
$T_{CLK/2}$	Start of data output	Rising edge of CLK shifts out one bit at a time	500			ns
$t_{DOvalid}$	Data output valid	Time between rising edge of CLK and data output valid			413	ns
$t_{DOtristate}$	Data output tri-state	After the last bit DO changes back to "tri-state"			100	ns
t_{CSn}	Pulse width of CSn	CSn =high; To initiate read-out of next angular position	500			ns
f_{CLK}	Read-out frequency	Clock frequency to read out serial data	>0		1	MHz
Pulse Width Modulation Output						
f_{PWM}	PWM frequency	Signal period = $4098\mu s \pm 10\%$ at $T_{AMB} = -40$ to $+150$ °C	220	244	268	Hz
PW_{MIN}	Minimum pulse width	Position 0d; angle 0 degree	0.90	1	1.10	μs
PW_{MAX}	Maximum pulse width	Position 4098d; angle 359.91 degrees	3686	4096	4506	μs
Programming Conditions						
t_{PROG}	Programming time per bit	Time to prog. a single fuse bit	10		20	μs
t_{CHARGE}	Refresh time per bit	Time to charge the cap after t_{PROG}	1			μs
f_{LOAD}	LOAD frequency	Data can be loaded at $n \times 2\mu s$			500	kHz
f_{READ}	READ frequency	Read the data from the latch			2.5	MHz
f_{WRITE}	WRITE frequency	Write the data to the latch			2.5	MHz



8 Detailed Description

The AS5145 is manufactured in a CMOS standard process and uses a spinning current Hall technology for sensing the magnetic field distribution across the surface of the chip. The integrated Hall elements are placed around the center of the device and deliver a voltage representation of the magnetic field at the surface of the IC.

Through Sigma-Delta Analog / Digital Conversion and Digital Signal-Processing (DSP) algorithms, the AS5145 provides accurate high-resolution absolute angular position information. For this purpose a Coordinate Rotation Digital Computer (CORDIC) calculates the angle and the magnitude of the Hall array signals.

The DSP is also used to provide digital information at the outputs MagINCn and MagDECn that indicate movements of the used magnet towards or away from the device's surface. A small low cost diametrically magnetized (two-pole) standard magnet provides the angular position information (see Figure 18).

The AS5145 senses the orientation of the magnetic field and calculates a 12-bit binary code. This code can be accessed via a Synchronous Serial Interface (SSI). In addition, an absolute angular representation is given by a Pulse Width Modulated signal at pin 12 (PWM). This PWM signal output also allows the generation of a direct proportional analog voltage, by using an external Low-Pass-Filter. The AS5145 is tolerant to magnet misalignment and magnetic stray fields due to differential measurement technique and Hall sensor conditioning circuitry.

Figure 4. Typical Arrangement of AS5145 and Magnet

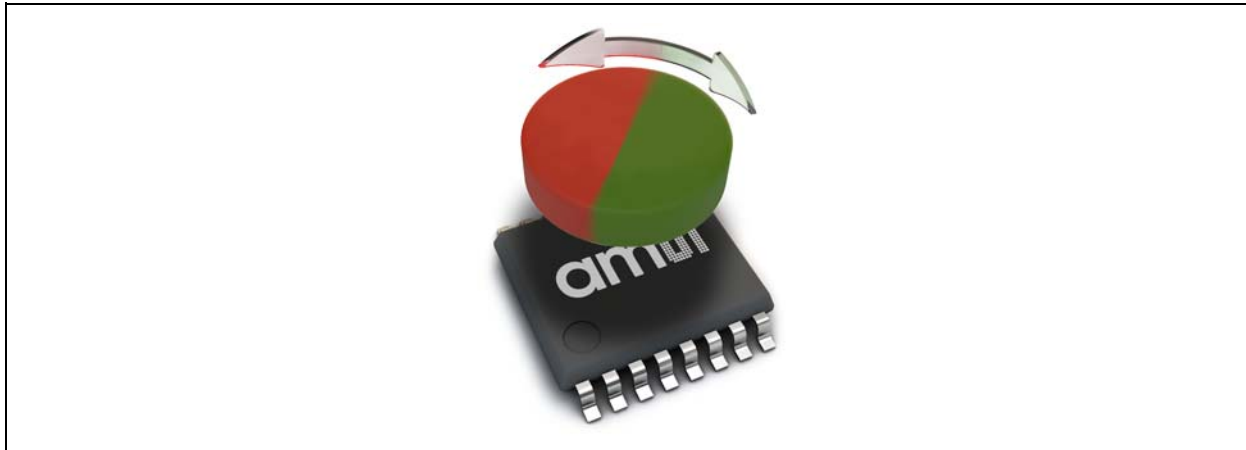

8.1 Mode_Index Pin

The Mode_Index pin activates or deactivates an internal filter that is used to reduce the analog output noise.

Activating the filter (Mode pin = LOW or open) provides a reduced output noise of 0.03° rms. At the same time, the output delay is increased to 384µs. This mode is recommended for high precision, low speed applications.

Deactivating the filter (Mode pin = HIGH) reduces the output delay to 96µs and provides an output noise of 0.06° rms. This mode is recommended for higher speed applications.

Setup the Mode pin affects the following parameters:

Table 7. Slow and Fast Mode Parameters

Parameter	Slow Mode (mode= low or open)	Fast Mode (mode=high, VDD= 5V)
Sampling rate	2.61 kHz (384 µs)	10.42 kHz (96µs)
Transition noise (1 sigma)	≤ 0.03° rms	≤ 0.06° rms
Output delay	384µs	96µs
Maximum speed @ 4096 samples/rev	38 rpm	153 rpm
Maximum speed @ 1024 samples/rev	153 rpm	610 rpm
Maximum speed @ 256 samples/rev	610 rpm	2441 rpm
Maximum speed @ 64 samples/rev	2441 rpm	9766 rpm

Note: A change of the Mode during operation is not allowed. The setup must be constant during power up and during operation.



8.1.1 Synchronous Serial Interface (SSI)

Figure 5. Synchronous Serial Interface with Absolute Angular Position Data

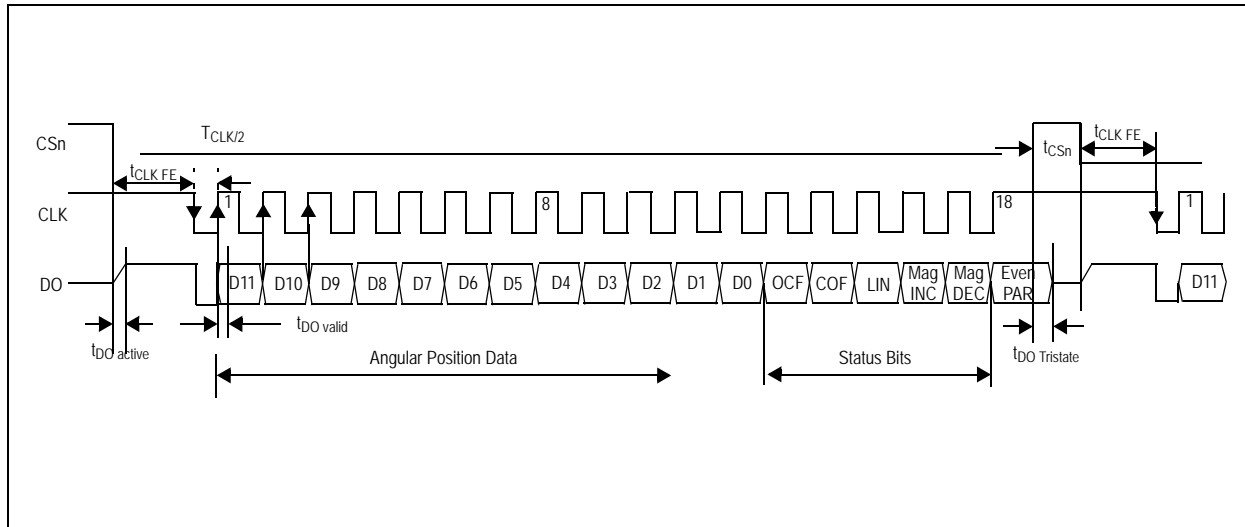

If CSn changes to logic low, Data Out (DO) will change from high impedance (tri-state) to logic high and the read-out will be initiated.

- After a minimum time $t_{CLK FE}$, data is latched into the output shift register with the first falling edge of CLK.
- Each subsequent rising CLK edge shifts out one bit of data.
- The serial word contains 18 bits, the first 12 bits are the angular information D[11:0], the subsequent 6 bits contain system information, about the validity of data such as OCF, COF, LIN, Parity and Magnetic Field status (increase/decrease).
- A subsequent measurement is initiated by a "high" pulse at CSn with a minimum duration of t_{CSn} .

Data Content

D11:D0 absolute angular position data (MSB is clocked out first)

OCF (Offset Compensation Finished), logic high indicates the finished Offset Compensation Algorithm

COF (Cordic Overflow), logic high indicates an out of range error in the CORDIC part. When this bit is set, the data at D11:D0 is invalid. The absolute output maintains the last valid angular value.

This alarm can be resolved by bringing the magnet within the X-Y-Z tolerance limits.

LIN (Linearity Alarm), logic high indicates that the input field generates a critical output linearity.

When this bit is set, the data at D11:D0 can still be used, but can contain invalid data. This warning can be resolved by bringing the magnet within the X-Y-Z tolerance limits.

Even Parity bit for transmission error detection of bits 1...17 (D11...D0, OCF, COF, LIN, MagINC, MagDEC)

Placing the magnet above the chip, angular values increase in clockwise direction by default.

Data D11:D0 is valid, when the status bits have the following configurations:

Table 8. Status Bit Outputs

OCF	COF	LIN	Mag INC	Mag DEC	Parity
1	0	0	0	0	Even checksum of bits 1:15
			0	1	
			1	0	
			1	1	

Note: MagInc=MagDec=1 is only recommended in YELLOW mode (see Table 9)



Z-axis Range Indication (Push Button Feature, Red/Yellow/Green Indicator). The AS5145 provides several options of detecting movement and distance of the magnet in the Z-direction. Signal indicators MagINCn and MagDECn are available both as hardware pins (pins #1 and 2) and as status bits in the serial data stream (see Figure 5).

In the default state, the status bits MagINC, MagDec and pins MagINCn, MagDECn have the following function:

Table 9. Magnetic Field Strength Red-Yellow-Green Indicator

Status Bits			Hardware Pins		OTP: Mag CompEn = 1 (Red-Yellow-Green)
Mac INC	Mag DEC	LIN	Mac INCn	Mag DECn	Description
0	0	0	Off	Off	No distance change Magnetic input field OK (GREEN range, ~45...75mT)
1	1	0	On	Off	YELLOW range: magnetic field is ~ 25...45mT or ~75...135mT. The AS5145 can still be operated in this range, but with slightly reduced accuracy.
1	1	1	On	On	RED range: magnetic field is ~<25mT or >~135mT. It is still possible to operate the AS5145 in the red range, but not recommended.
All other combinations			n/a	n/a	Not available

Note: Pin 1 (MagINCn) and pin 2 (MagDECn) are active low via open drain output and require an external pull-up resistor. If the magnetic field is in range, both outputs are turned off.

The two pins can also be combined with a single pull-up resistor. In this case, the signal is high when the magnetic field is in range. It is low in all other cases (see Table 9).

8.1.2 Incremental Mode

The AS5145 has an internal interpolator block. This function is used if the input magnetic field is too fast and a code position is missing. In this case an interpolation is done.

With the OTP bits OutputMd0 and OutputMd1 a specific mode can be selected. For the available pre-programmed incremental versions (10-bit and 12-bit), these bits are set during test at ams. These settings are permanent and can not be recovered.

A change of the incremental mode (WRITE command) during operation could cause problems. A power-on-reset in between is recommended.

Table 10. Incremental Resolution

Mode	Description	Output Md1	Output Md0	Resolution	DTest1_A and DTest2_B Pulses	Index Width
Default mode	AS5145 function DTEST1_A and DTEST2_B are not used. The Mode_Index pin is used for selection of the decimation rate (low speed/high speed).	0	0			
10-bit Incremental mode (low DNL)	DTEST1_A and DTEST2_B are used as A and B signal. In this mode the Mode_Index Pin is switched from input to output and will be the Index Pin. The decimation rate is set to 64 (fast mode) and cannot be changed from external.	0	1	10	256	1/3 LSB
12-bit Incremental mode (high DNL)		1	0	12	1024	
Sync mode	In this mode a control signal is switched to DTEST1_A and DTEST2_B.	1	1			



Incremental Power-up Lock Option. After power-up, the incremental outputs can optionally be locked or unlocked, depending on the status of the CSn pin:

- CSn = low at power-up: CSn has an internal pull-up resistor and must be externally pulled low ($R_{ext} \leq 5k\Omega$). If CSn is low at power-up, the incremental outputs (A, B, Index) will be high until the internal offset compensation is finished. This unique state (A=B=Index = high) can be used as an indicator for the external controller to shorten the waiting time at power-up. Instead of waiting for the specified maximum power up-time (0), the controller can start requesting data from the AS5145 as soon as the state (A=B=Index = high) is cleared.
- CSn = high or open at power-up: In this mode, the incremental outputs (A, B, Index) will remain at logic high state, until CSn goes low or a low pulse is applied at CSn. This mode allows intentional disabling of the incremental outputs until, for example the system microcontroller is ready to receive data.

Figure 6. Incremental Output

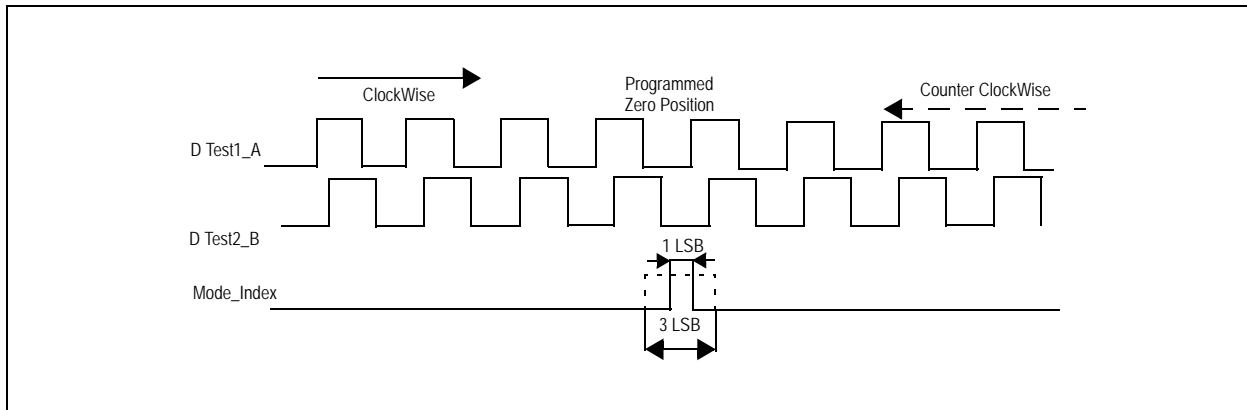

The hysteresis trimming is done at the final test (factory trimming) and set to 4 LSB, related to a 12-bit number.

Incremental Output Hysteresis. To avoid flickering incremental outputs at a stationary magnet position, a hysteresis is introduced. In case of a rotational direction change, the incremental outputs have a hysteresis of 4 LSB. Regardless of the programmed incremental resolution, the hysteresis of 4 LSB always corresponds to the highest resolution of 12-bit. In absolute terms, the hysteresis is set to 0.35 degrees for all resolutions. For constant rotational directions, every magnet position change is indicated at the incremental outputs (see Figure 7). For example, if the magnet turns clockwise from position "x+3" to "x+4", the incremental output would also indicate this position accordingly. A change of the magnet's rotational direction back to position "x+3" means that the incremental output still remains unchanged for the duration of 4 LSB, until position "x+2" is reached. Following this direction, the incremental outputs will again be updated with every change of the magnet position.

Figure 7. Hysteresis Window for Incremental Outputs

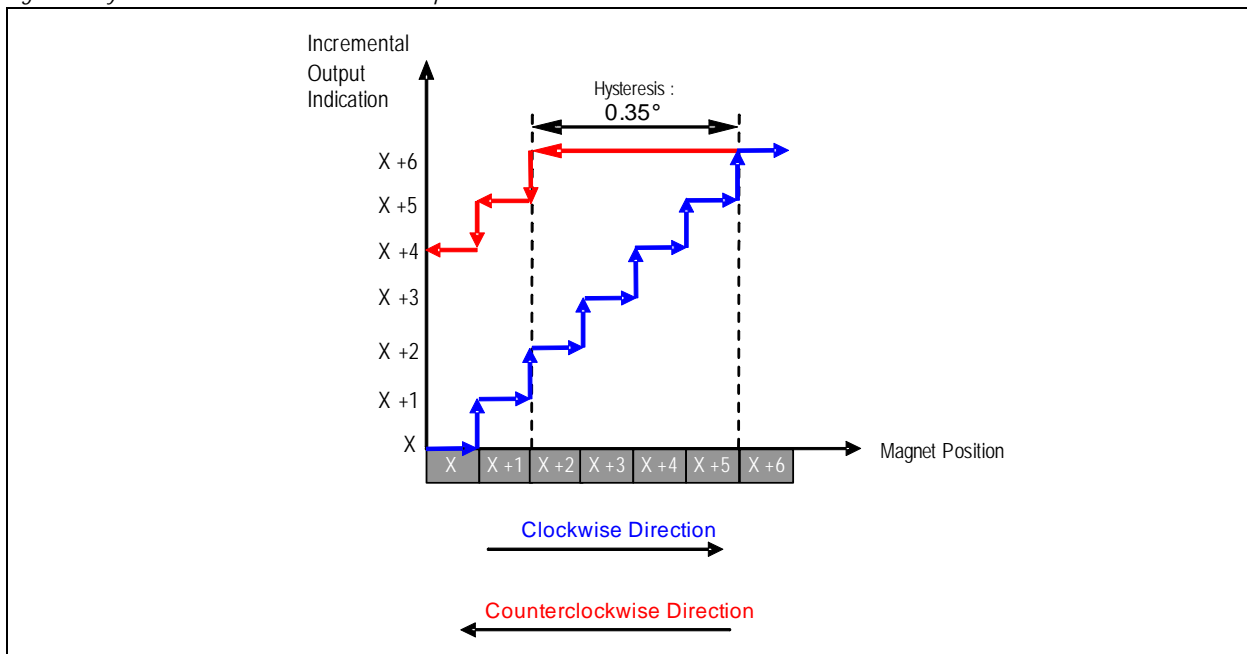



Incremental Output Validity. During power on the incremental output is kept stable high until the offset compensation is finished and the CSn is low (internal Pull Up) the first time. In quadrature mode $A = B = \text{Index} = \text{high}$ indicates an invalid output. If the interpolator recognizes a difference larger than 128 steps between two samples it holds the last valid state. The interpolator synchronizes up again with the next valid difference. This avoids undefined output burst, e.g. if no magnet is present.

8.1.3 Sync Mode

This mode is used to synchronize the external electronic with the AS5145. In this mode two signals are provided at the pins DTEST1_A and DTEST2_B. By setting of Md0=1 and Md1=1 in the OTP register, the Sync Mode will be activated.

Figure 8. DTest1_A and DTest2_B

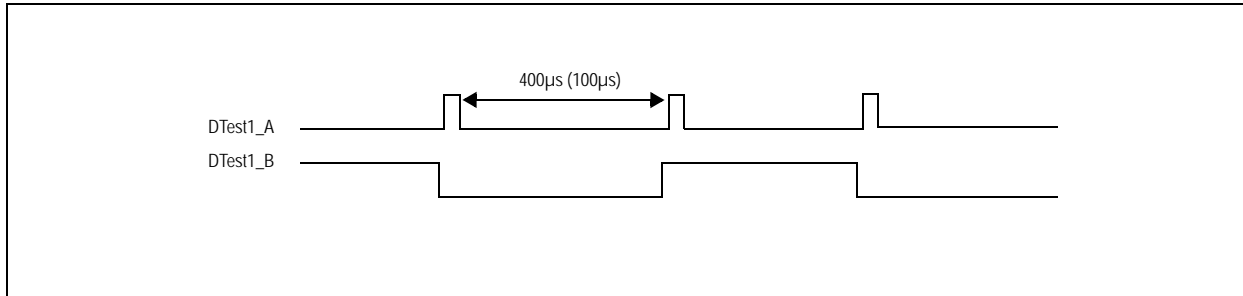

Every rising edge at DTEST1_A indicates that new data in the device is available. With this signal it is possible to trigger an external customer Microcontroller (interrupt) and start the SSI readout. DTEST2_B indicates the phase of available data.

8.1.4 Sin/Cosine Mode

This mode can be enabled by setting the OTP Factory-bit FS2. If this mode is activated the 16 bit sinus and 16 bit cosines digital data of both channels will be switched out. Due to the high resolution of 16 bits of the data stream an accurate calculation can be done externally. In this mode the open drain outputs of DTEST1_A and DTEST2_B are switched to push-pull mode. At Pin MagDECn the clock impulse, at Pin MagINCn the Enable pulse will be switched out. The Pin PWM indicates, which phase of signal is being presented. The mode isn't available in the default mode.

8.1.5 Daisy Chain Mode

The Daisy Chain mode allows connection of several AS5145s in series, while still keeping just one digital input for data transfer (see "Data IN" in Figure 9). This mode is accomplished by connecting the data output (DO; pin 9) to the data input (PDIO; pin 8) of the subsequent device. The serial data of all connected devices is read from the DO pin of the first device in the chain. The length of the serial bit stream increases with every connected device, it is $n * (18+1)$ bits: n = number of devices. e.g. 38 bit for two devices, 57 bit for three devices, etc.

The last data bit of the first device (Parity) is followed by a dummy bit and the first data bit of the second device (D11), etc. (see Figure 10).

Figure 9. Daisy Chain Hardware Configuration

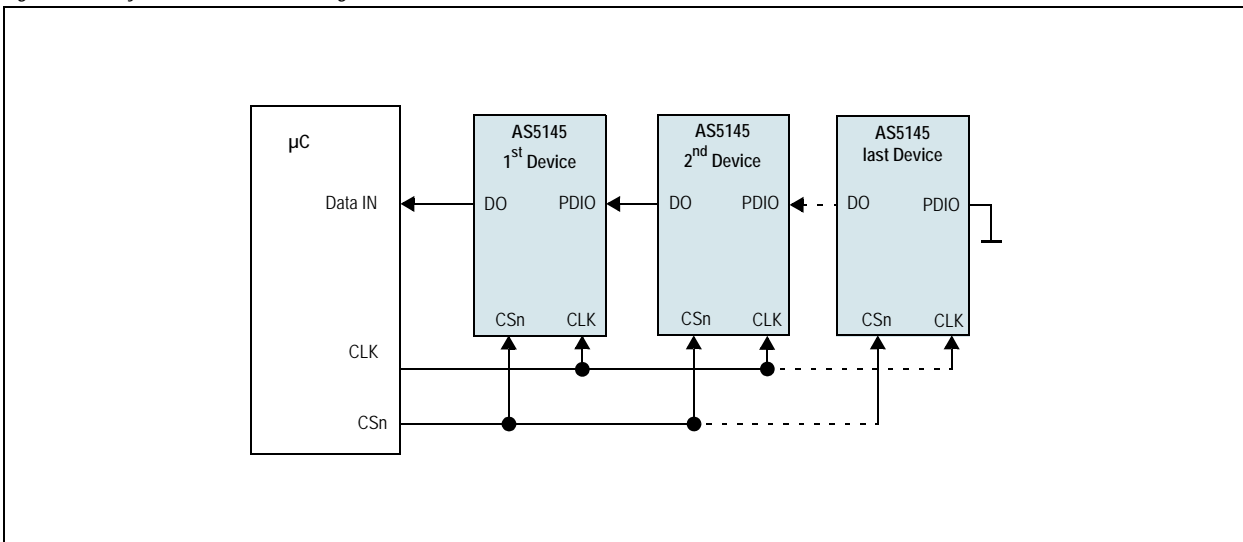
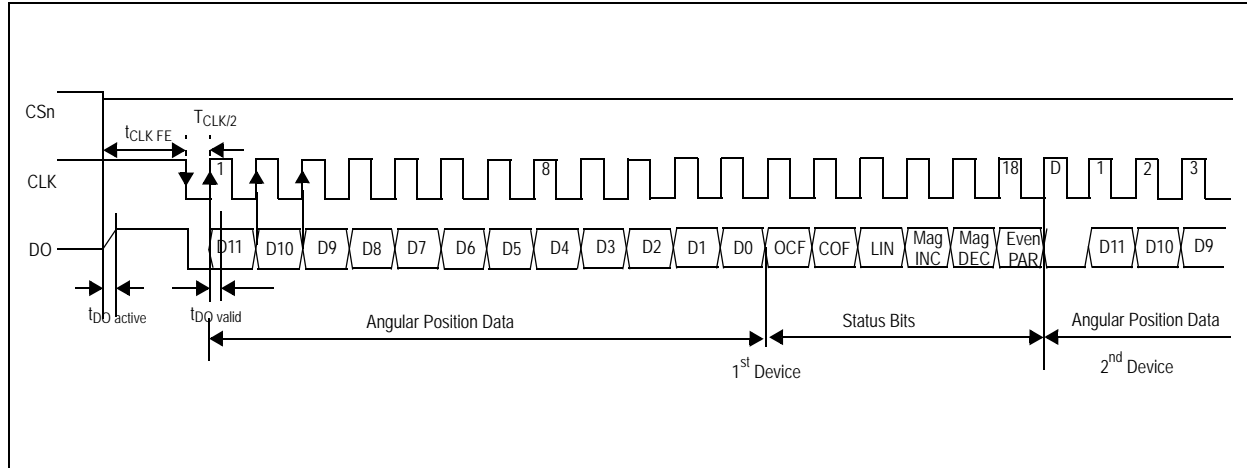



Figure 10. Daisy Chain Mode Data Transfer



8.2 Pulse Width Modulation (PWM) Output

The AS5145 provides a pulse width modulated output (PWM), whose duty cycle is proportional to the measured angle. For angle position 0 to 4094

$$Position = \frac{t_{on} \cdot 4098}{(t_{on} + t_{off})} - 1 \tag{EQ 1}$$

Examples:

1. An angle position of 180° will generate a pulse width $t_{on} = 2049\mu s$ and a pause t_{off} of $2049\mu s$ resulting in Position = 2048 after the calculation: $2049 \cdot 4098 / (2049 + 2049) - 1 = 2048$
2. An angle position of 359.8° will generate a pulse width $t_{on} = 4095\mu s$ and a pause t_{off} of $3\mu s$ resulting in Position = 4094 after the calculation: $4095 \cdot 4098 / (4095 + 3) - 1 = 4094$

Exception:

1. An angle position of 359.9° will generate a pulse width $t_{on} = 4097\mu s$ and a pause t_{off} of $1\mu s$ resulting in Position = 4096 after the calculation: $4097 \cdot 4098 / (4097 + 1) - 1 = 4096$

The PWM frequency is internally trimmed to an accuracy of $\pm 5\%$ ($\pm 10\%$ over full temperature range). This tolerance can be cancelled by measuring the complete duty cycle as shown above.

Figure 11. PWM Output Signal

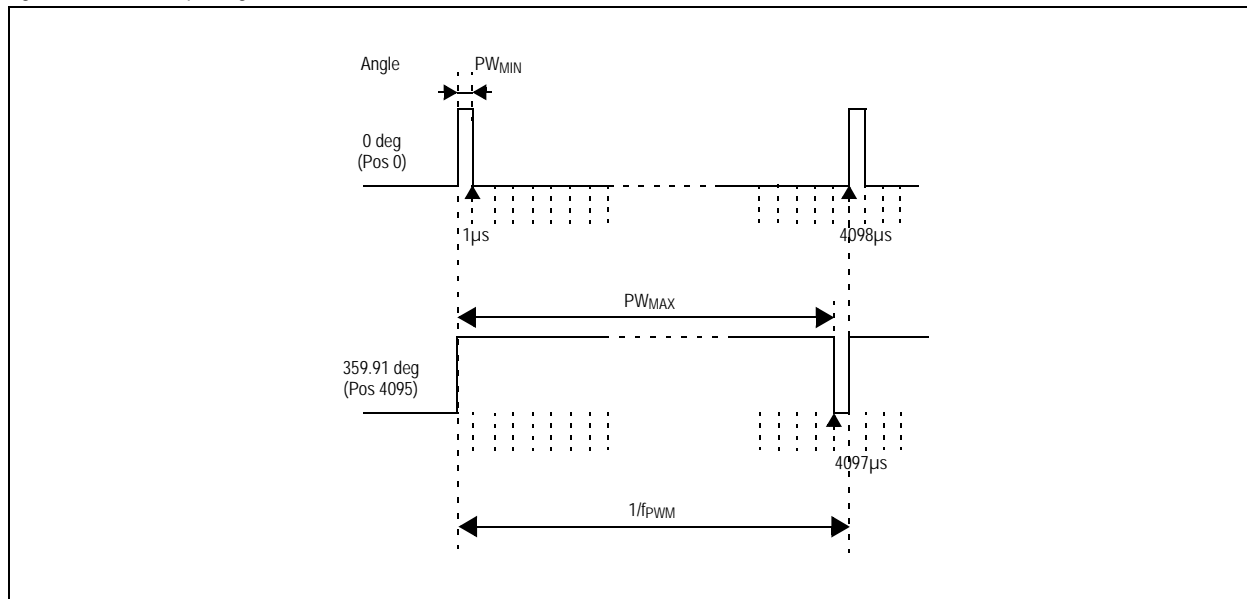



8.2.1 Changing the PWM Frequency

The PWM frequency of the AS5145 can be divided by two by setting a bit (PWMhalfEN) in the OTP register (see [Programming the AS5145 on page 19](#)). With PWMhalfEN = 0 the PWM timing is as shown in [Table 11](#):

Table 11. PWM Signal Parameters (Default mode)

Symbol	Parameter	Typ	Unit	Note
f_{PWM}	PWM frequency	244	Hz	Signal period: 4097 μ s
PW_{MIN}	MIN pulse width	1	μ s	- Position 0d - Angle 0 deg
PW_{MAX}	MAX pulse width	4097	μ s	- Position 4095d - Angle 359.91 deg

When PWMhalfEN = 1, the PWM timing is as shown in [Table 12](#):

Table 12. PWM Signal Parameters with Half Frequency (OTP option)

Symbol	Parameter	Typ	Unit	Note
f_{PWM}	PWM frequency	122	Hz	Signal period: 8194 μ s
PW_{MIN}	MIN pulse width	2	μ s	- Position 0d - Angle 0 deg
PW_{MAX}	MAX pulse width	8194	μ s	- Position 4095d - Angle 359.91 deg

8.3 Analog Output

An analog output can be generated by averaging the PWM signal, using an external active or passive low pass filter. The analog output voltage is proportional to the angle: 0° = 0V; 360° = VDD5V.

Using this method, the AS5145 can be used as direct replacement of potentiometers.

Figure 12. Simple 2nd Order Passive RC Low Pass Filter

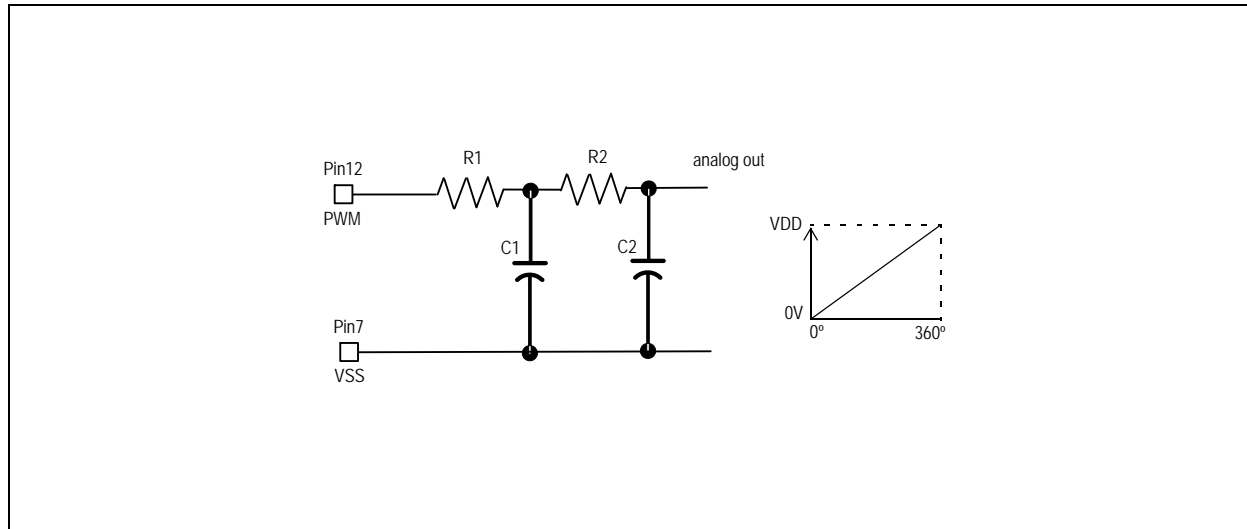

Figure 11 shows an example of a simple passive low pass filter to generate the analog output.

$$R1, R2 \geq 10k\Omega \quad C1, C2 \geq 2.2\mu F / 6V \quad (EQ 2)$$

R1 should be greater than or equal to 4k Ω to avoid loading of the PWM output. Larger values of Rx and Cx will provide better filtering and less ripple, but will also slow down the response time.



9 Application Information

The benefits of AS5145 are as follows:

- Complete system-on-chip
- Flexible system solution provides absolute and PWM outputs simultaneously
- Ideal for applications in harsh environments due to contactless position sensing
- No calibration required
- No temperature compensation necessary

9.1 Programming the AS5145

After power-on, programming the AS5145 is enabled with the rising edge of CS_n with PDIO = high and CLK = low.

The AS5145 programming is a one-time-programming (OTP) method, based on poly silicon fuses. The advantage of this method is that a programming voltage of only 3.3V to 3.6V is required for programming (either with 3.3V or 5V supply).

The OTP consists of 52 bits, of which 21 bits are available for user programming. The remaining 31 bits contain factory settings and a unique chip identifier (Chip-ID).

A single OTP cell can be programmed only once. Per default, the cell is "0"; a programmed cell will contain a "1". While it is not possible to reset a programmed bit from "1" to "0", multiple OTP writes are possible, as long as only unprogrammed "0"-bits are programmed to "1".

Independent of the OTP programming, it is possible to overwrite the OTP register temporarily with an OTP write command at any time. This setting will be cleared and overwritten with the hard programmed OTP settings at each power-up sequence or by a LOAD operation. Use **application note AN514X_10** to get more information about the programming options.

The OTP memory can be accessed in the following ways:

- **Load Operation:** The Load operation reads the OTP fuses and loads the contents into the OTP register. A Load operation is automatically executed after each power-on-reset.
- **Write Operation:** The Write operation allows a temporary modification of the OTP register. It does not program the OTP. This operation can be invoked multiple times and will remain set while the chip is supplied with power and while the OTP register is not modified with another Write or Load operation.
- **Read Operation:** The Read operation reads the contents of the OTP register, for example to verify a Write command or to read the OTP memory after a Load command.
- **Program Operation:** The Program operation writes the contents of the OTP register permanently into the OTP ROM.
- **Analog Readback Operation:** The Analog Readback operation allows a quantifiable verification of the programming. For each programmed or unprogrammed bit, there is a representative analog value (in essence, a resistor value) that is read to verify whether a bit has been successfully programmed or not.

9.1.1 Zero Position Programming

Zero position programming is an OTP option that simplifies assembly of a system, as the magnet does not need to be manually adjusted to the mechanical zero position. Once the assembly is completed, the mechanical and electrical zero positions can be matched by software. Any position within a full turn can be defined as the permanent new zero position.

For zero position programming, the magnet is turned to the mechanical zero position (e.g. the "off"-position of a rotary switch) and the actual angular value is read.

This value is written into the OTP register bits Z35:Z46 (see [Figure 13](#)).

Note: The zero position value can also be modified before programming, e.g. to program an electrical zero position that is 180° (half turn) from the mechanical zero position, just add 2048 to the value read at the mechanical zero position and program the new value into the OTP register.



9.1.2 OTP Memory Assignment

Table 13. OTP Bit Assignment

Bit	Symbol	Function	
	mbit1	Factory Bit 1	
51	PWMhalfEN_Index width	PMW frequency Index pulse width	Customer Section
50	MagCompEn	Alarm mode (programmed by ams to 1)	
49	pwmDIS	Disable PWM	
48	Output Md0	Default, 10-bit inc, 12-bit inc Sync mode	
47	Output Md1		
46	Z0	12-bit Zero Position	
:	:		
35	Z11		
34	CCW	Direction	
33	RA0	Redundancy Address	
:	:		
29	RA4		
28	FS 0	Factory Bit	Factory Section
27	FS 1		
26	FS 2		
25	FS 3		
24	FS 4		
23	FS 5		
:	:		
20	FS 8		
19	FS 9		
18	FS 10		
17	ChipID0	18-bit Chip ID	ID Section
16	ChipID1		
:	:		
0	ChipID17		
	mbit0	Factory Bit 0	

9.1.3 User Selectable Settings

The AS5145 allows programming of the following user selectable options:

- **PWMhalfEN_Indexwidth**: Setting this bit, the PWM pulse will be divided by 2, in case of quadrature incremental mode A/B/Index setting of Index impulse width from 1 LSB to 3LSB
- **Output Md0**: Setting this bit enables sync- or 10-bit incremental mode (see Table 10).
- **Output Md1**: Setting this bit enables sync- or 12-bit incremental mode (see Table 10).
- **Z [11:0]**: Programmable Zero / Index Position



- **CCW:** Counter Clockwise Bit
 ccw=0 – angular value increases in clockwise direction
 ccw=1 – angular value increases in counterclockwise direction
- **RA [4:0]:** Redundant Address: an OTP bit location addressed by this address is always set to "1" independent of the corresponding original OTP bit setting

9.1.4 OTP Default Setting

The AS5145 can also be operated without programming. The default, un-programmed setting is:

- **Output Md0, Output MD1:** 00= Default mode
- **Z0 to Z11:** 00 = no programmed zero position
- **CCW:** 0 = clockwise operation
- **RA4 to RA0:** 0 = no OTP bit is selected
- **MagCompEN:** 1 = The green/yellow Mode is enabled

9.1.5 Redundancy

For a better programming reliability a redundancy is implemented. In case when the programming of one bit failed this function can be used. With an address RA(4:0) one bit can be selected and programmed.

Table 14. Redundancy Addressing

Address	PWMhalfEN_Indexwidth	MagCompEN	pwmDJS	Output Md0	Output Md1	Z0	Z1	Z2	Z3	Z4	Z5	Z6	Z7	Z8	Z9	Z10	Z11	CCW
00000	0	0	0	0	0	0	0	0	0	0	0	0	0	0	0	0	0	0
00001	1	0	0	0	0	0	0	0	0	0	0	0	0	0	0	0	0	0
00010	0	1	0	0	0	0	0	0	0	0	0	0	0	0	0	0	0	0
00011	0	0	1	0	0	0	0	0	0	0	0	0	0	0	0	0	0	0
00100	0	0	0	1	0	0	0	0	0	0	0	0	0	0	0	0	0	0
00101	0	0	0	0	1	0	0	0	0	0	0	0	0	0	0	0	0	0
00110	0	0	0	0	0	1	0	0	0	0	0	0	0	0	0	0	0	0
00111	0	0	0	0	0	0	1	0	0	0	0	0	0	0	0	0	0	0
01000	0	0	0	0	0	0	0	1	0	0	0	0	0	0	0	0	0	0
01001	0	0	0	0	0	0	0	0	1	0	0	0	0	0	0	0	0	0
01010	0	0	0	0	0	0	0	0	0	1	0	0	0	0	0	0	0	0
01011	0	0	0	0	0	0	0	0	0	0	1	0	0	0	0	0	0	0
01100	0	0	0	0	0	0	0	0	0	0	0	1	0	0	0	0	0	0
01101	0	0	0	0	0	0	0	0	0	0	0	0	1	0	0	0	0	0
01110	0	0	0	0	0	0	0	0	0	0	0	0	0	1	0	0	0	0
01111	0	0	0	0	0	0	0	0	0	0	0	0	0	0	1	0	0	0
10000	0	0	0	0	0	0	0	0	0	0	0	0	0	0	0	1	0	0
10001	0	0	0	0	0	0	0	0	0	0	0	0	0	0	0	0	1	0
10010	0	0	0	0	0	0	0	0	0	0	0	0	0	0	0	0	0	1
10101	1	1	1	1	1	1	1	1	1	1	1	1	1	1	1	1	1	1



9.1.6 Redundant Programming Option

In addition to the regular programming, a redundant programming option is available. This option allows that one selectable OTP bit can be set to "1" (programmed state) by writing the location of that bit into a 5-bit address decoder. This address can be stored in bits RA4...RA0 in the OTP user settings.

Example: setting RA4...0 to "00001" will select bit 51 = PWhalfEN_Indexwidth, "00010" selects bit 50 = MagCompEN, "10010" selects bit 34 =CCW, etc.

9.1.7 OTP Register Entry and Exit Condition

For timing options, refer to [Programming the AS5145 \(page 19\)](#).

Figure 13. OTP Access Timing Diagram

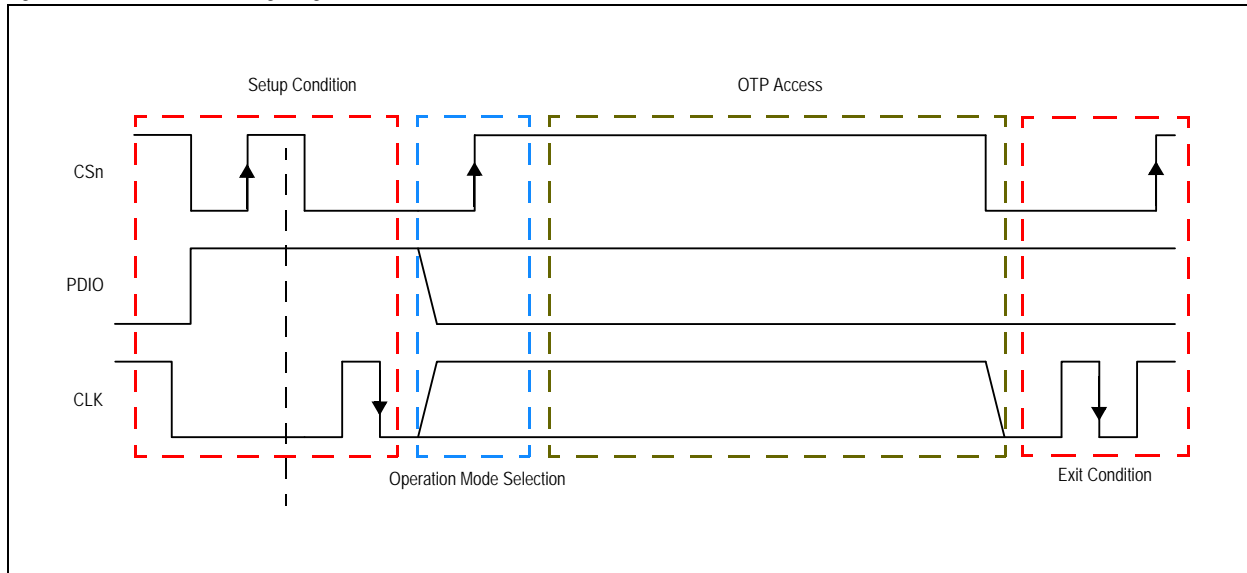

To avoid accidental modification of the OTP during normal operation, each OTP access (Load, Write, Read, Program) requires a defined entry and exit procedure, using the CSn, PDIO and CLK signals as shown in [Figure 13](#).

Figure 14. OTP Programming Connection

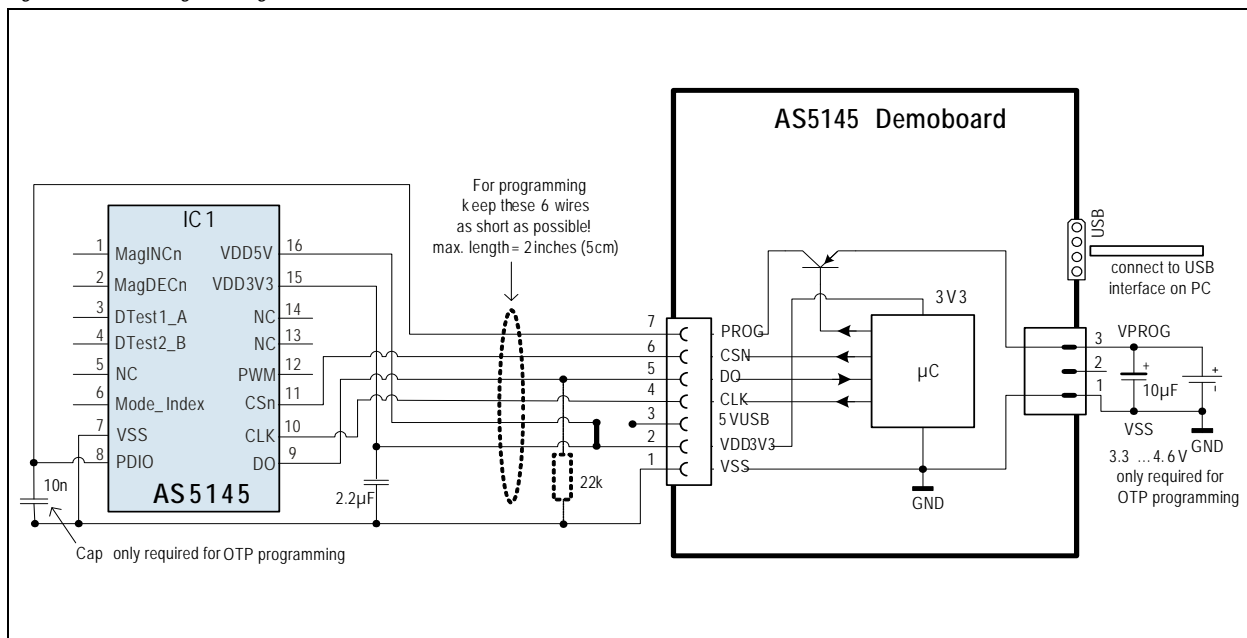



9.2 Alignment Mode

The alignment mode simplifies centering the magnet over the center of the chip to gain maximum accuracy.

Alignment mode can be enabled with the falling edge of CSn while PDIO = logic high (see Figure 15). The Data bits D11-D0 of the SSI change to a 12-bit displacement amplitude output. A high value indicates large X or Y displacement, but also higher absolute magnetic field strength. The magnet is properly aligned, when the difference between highest and lowest value over one full turn is at a minimum.

Under normal conditions, a properly aligned magnet will result in a reading of less than 128 over a full turn.

The MagINCn and MagDECn indicators will be = 1 when the alignment mode reading is < 128. At the same time, both hardware pins MagINCn (#1) and MagDECn (#2) will be pulled to VSS. A properly aligned magnet will therefore produce a MagINCn = MagDECn = 1 signal throughout a full 360° turn of the magnet.

Stronger magnets or short gaps between magnet and IC will show values larger than 128. These magnets are still properly aligned as long as the difference between highest and lowest value over one full turn is at a minimum.

The Alignment mode can be reset to normal operation by a power-on-reset (disconnect / re-connect power supply) or by a falling edge on CSn with PDIO = low.

Figure 15. Enabling the Alignment Mode

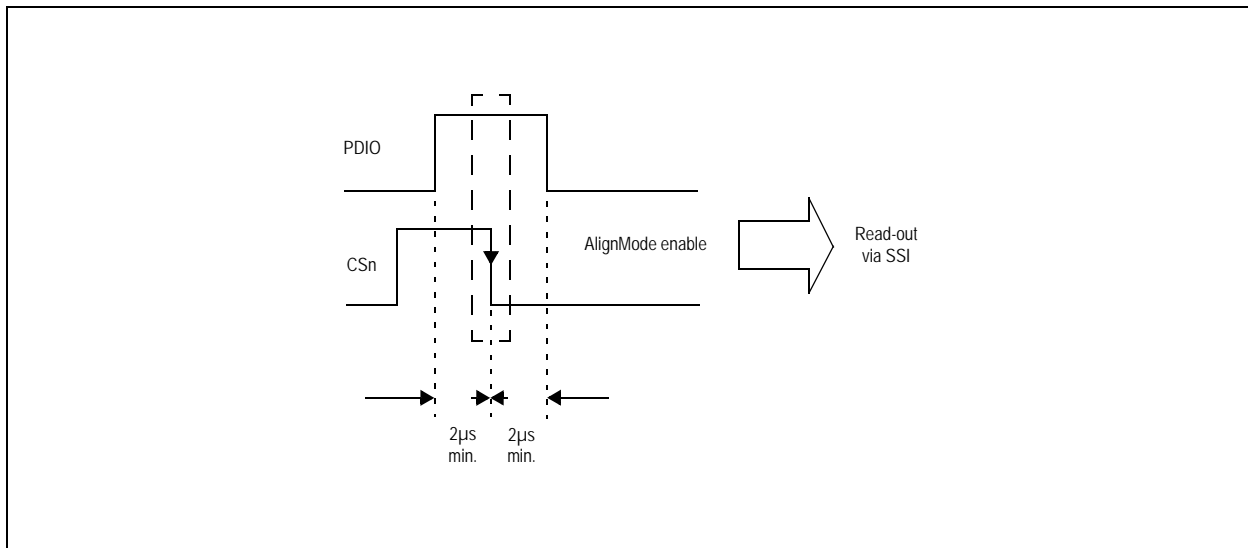
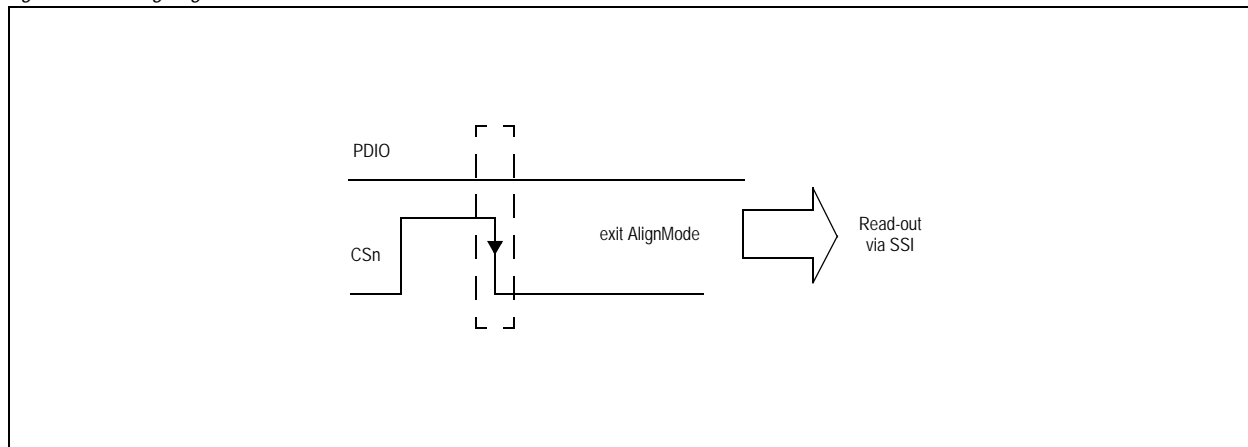

Figure 16. Exiting Alignment Mode





9.3 3.3V / 5V Operation

The AS5145 operates either at $3.3V \pm 10\%$ or at $5V \pm 10\%$. This is made possible by an internal 3.3V Low-Dropout (LDO) Voltage regulator. The internal supply voltage is always taken from the output of the LDO, meaning that the internal blocks are always operating at 3.3V.

For 3.3V operation, the LDO must be bypassed by connecting VDD3V3 with VDD5V (see Figure 17).

For 5V operation, the 5V supply is connected to pin VDD5V, while VDD3V3 (LDO output) must be buffered by a $1 \dots 10\mu F$ capacitor, which is supposed to be placed close to the supply pin (see Figure 17) with recommended $2.2\mu F$.

Note: The VDD3V3 output is intended for internal use only. It must not be loaded with an external load.

The output voltage of the digital interface I/O's corresponds to the voltage at pin VDD5V, as the I/O buffers are supplied from this pin.

Figure 17. Connections for 5V / 3.3V Supply Voltages

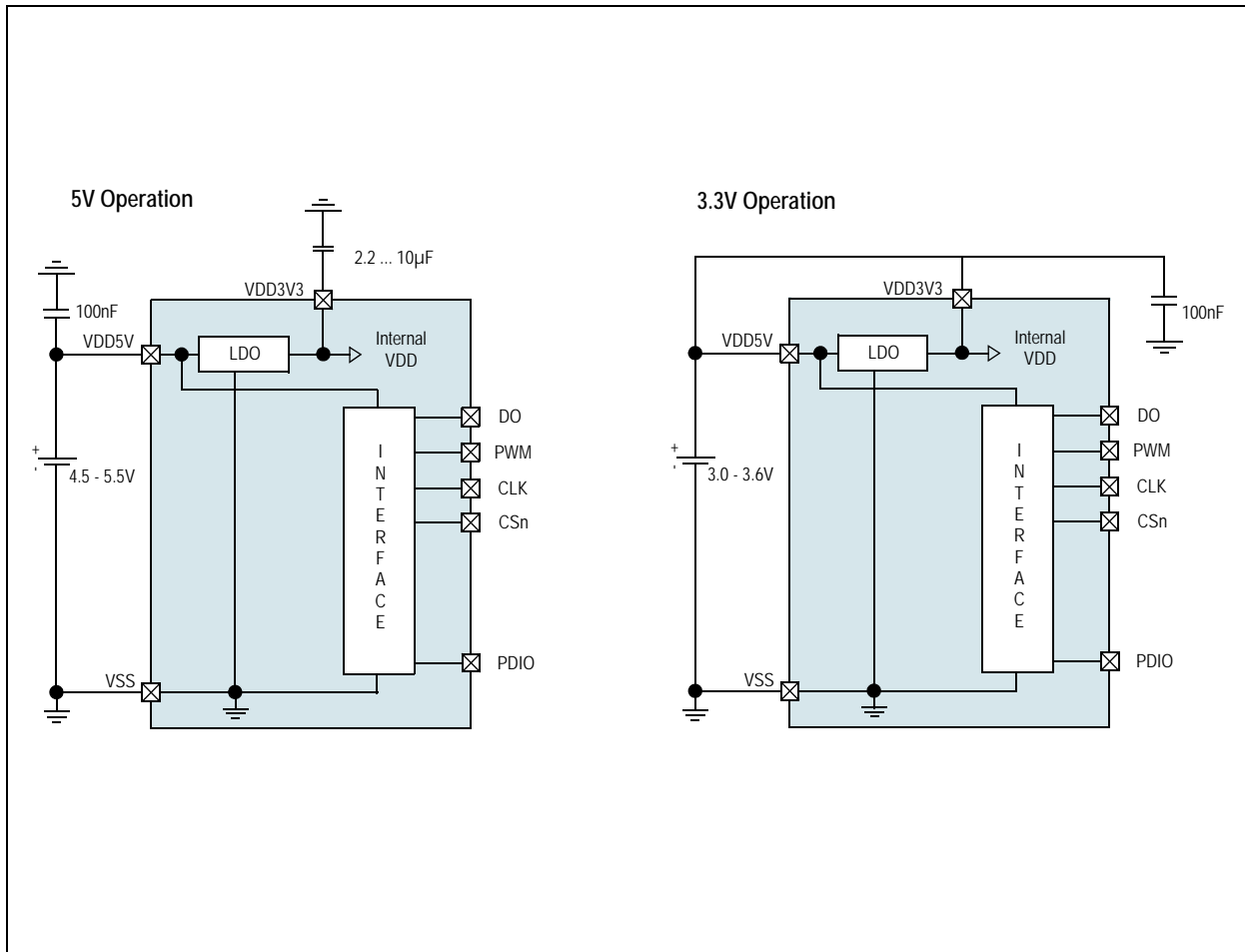

A buffer capacitor of 100nF is recommended in both cases close to pin VDD 5V. Note that pin VDD 3V3 must always be buffered by a capacitor. It must not be left floating, as this may cause an unstable internal 3.3V supply voltage which can lead to larger than normal jitter of the measured angle.

9.4 Selecting Proper Magnet

Typically the magnet is 6mm in diameter and 2.5mm in height. Magnetic materials such as rare earth AlNiCo/SmCo5 or NdFeB are recommended. The magnetic field strength perpendicular to the die surface has to be in the range of $\pm 45mT \dots \pm 75mT$ (peak).

The magnet's field strength is verified using a gauss-meter. The magnetic field Bv at a given distance, along a concentric circle with a radius of 1.1mm (R1) is in the range of $\pm 45mT \dots \pm 75mT$ (see Figure 18).



Figure 18. Typical Magnet (6x3mm) and Magnetic Field Distribution

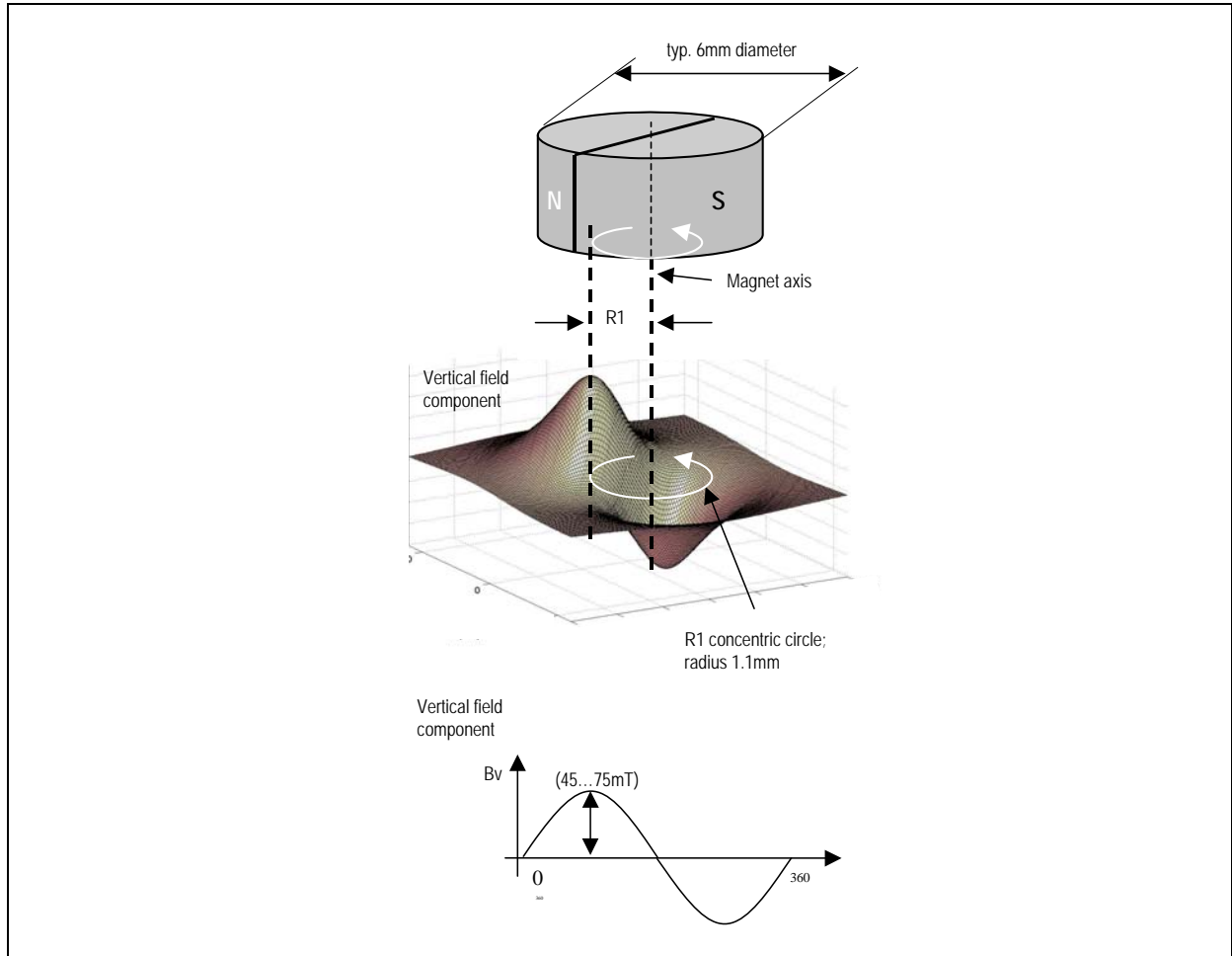

9.4.1 Physical Placement of the Magnet

The best linearity can be achieved by placing the center of the magnet exactly over the defined center of the chip as shown in the drawing below:

Figure 19. Defined Chip Center and Magnet Displacement Radius

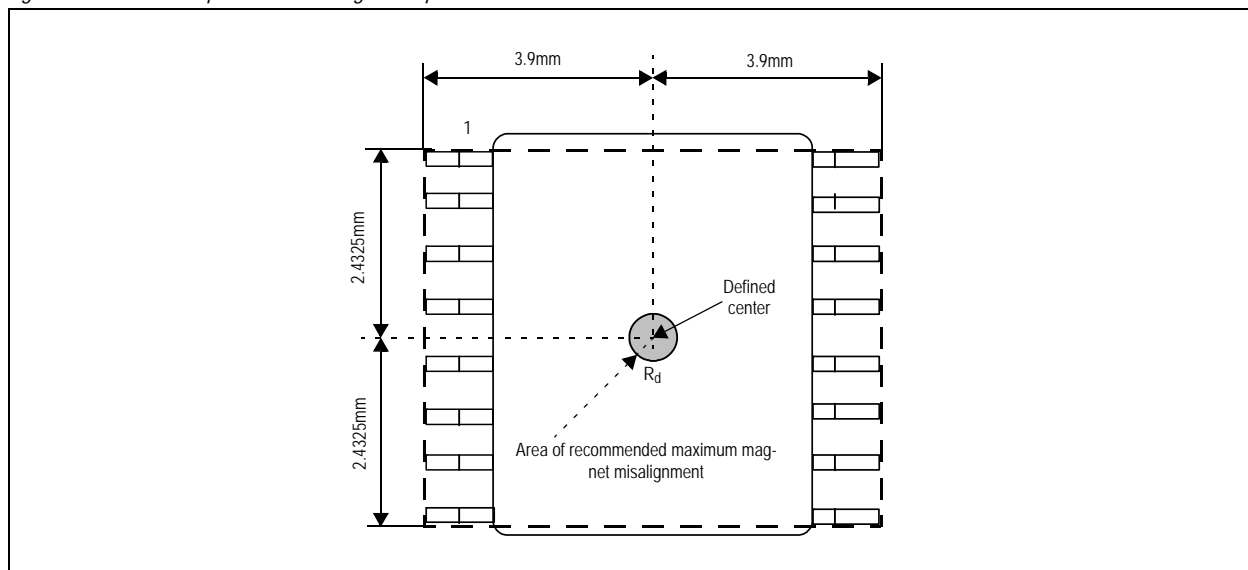



9.4.2 Magnet Placement

The magnet's center axis must be aligned within a displacement radius R_d of 0.25mm from the defined center of the IC. The magnet can be placed below or above the device. The distance can be chosen such that the magnetic field on the die surface is within the specified limits (see [Figure 19](#)). The typical distance "z" between the magnet and the package surface is 0.5mm to 1.5mm, provided the use of the recommended magnet material and dimensions (6mm x 3mm). Larger distances are possible, as long as the required magnetic field strength stays within the defined limits.

A magnetic field outside the specified range still can be detected by the chip. But the out-of-range condition will be indicated by MagINCn (pin 1) and MagDECn (pin 2), (see [Table 1](#)).

9.5 Failure Diagnostics

The AS5145 also offers several diagnostic and failure detection features:

9.5.1 Magnetic Field Strength Diagnosis

By software: the MagINC and MagDEC status bits will both be high when the magnetic field is out of range.

By hardware: Pins #1 (MagINCn) and #2 (MagDECn) are open-drain outputs and will both be turned on (= low with external pull-up resistor) when the magnetic field is out of range. If only one of the outputs are low, the magnet is either moving towards the chip (MagINCn) or away from the chip (MagDECn).

9.5.2 Power Supply Failure Detection

By software: If the power supply to the AS5145 is interrupted, the digital data read by the SSI will be all "0"s. Data is only valid, when bit OCF is high, hence a data stream with all "0"s is invalid. To ensure adequate low levels in the failure case, a pull-down resistor (~10k Ω) must be added between pin DIO and VSS at the receiving side.

By hardware: The MagINCn and MagDECn pins are open drain outputs and require external pull-up resistors. In normal operation, these pins are high ohmic and the outputs are high (see [Table 9](#)). In a failure case, either when the magnetic field is out of range of the power supply is missing, these outputs will become low. To ensure adequate low levels in case of a broken power supply to the AS5145, the pull-up resistors (~10k Ω) from each pin must be connected to the positive supply at pin 16 (VDD5V).

By hardware: PWM output: The PWM output is a constant stream of pulses with 1kHz repetition frequency. In case of power loss, these pulses are missing.

9.6 Angular Output Tolerances

9.6.1 Accuracy

Accuracy is defined as the error between measured angle and actual angle. It is influenced by several factors:

- The non-linearity of the analog-digital converters
- Internal gain and mismatch errors
- Non-linearity due to misalignment of the magnet

As a sum of all these errors, the accuracy with centered magnet = $(Err_{max} - Err_{min})/2$ is specified as better than ± 0.5 degrees @ 25°C (see [Figure 21](#)).

Misalignment of the magnet further reduces the accuracy. [Figure 20](#) shows an example of a 3D-graph displaying non-linearity over XY-misalignment. The center of the square XY-area corresponds to a centered magnet (see dot in the center of the graph). The X- and Y- axis extends to a misalignment of ± 1 mm in both directions. The total misalignment area of the graph covers a square of 2x2mm (79x79mil) with a step size of 100 μ m.

For each misalignment step, the measurement as shown in [Figure 21](#) is repeated and the accuracy $(Err_{max} - Err_{min})/2$ (e.g. 0.25° in [Figure 21](#)) is entered as the Z-axis in the 3D-graph.



Figure 20. Example of Linearity Error Over XY Misalignment

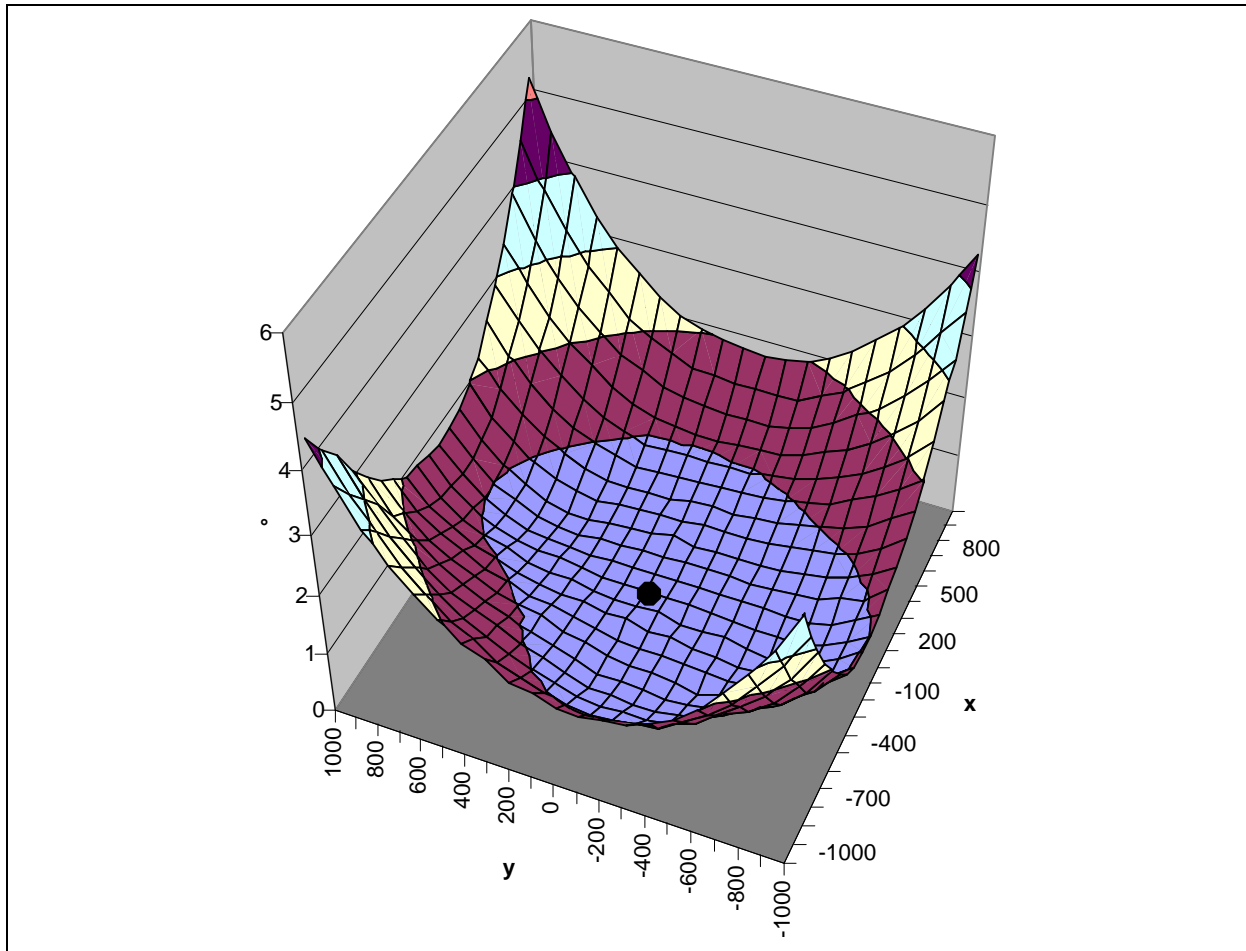

The maximum non-linearity error on this example is better than ± 1 degree (inner circle) over a misalignment radius of ~ 0.7 mm. For volume production, the placement tolerance of the IC within the package (± 0.235 mm) must also be taken into account.

The total nonlinearity error over process tolerances, temperature and a misalignment circle radius of 0.25mm is specified better than ± 1.4 degrees. The magnet used for this measurement was a cylindrical NdFeB (Bomatec® BMN-35H) magnet with 6mm diameter and 2.5mm in height.

Figure 21. Example of Linearity Error Over 360°

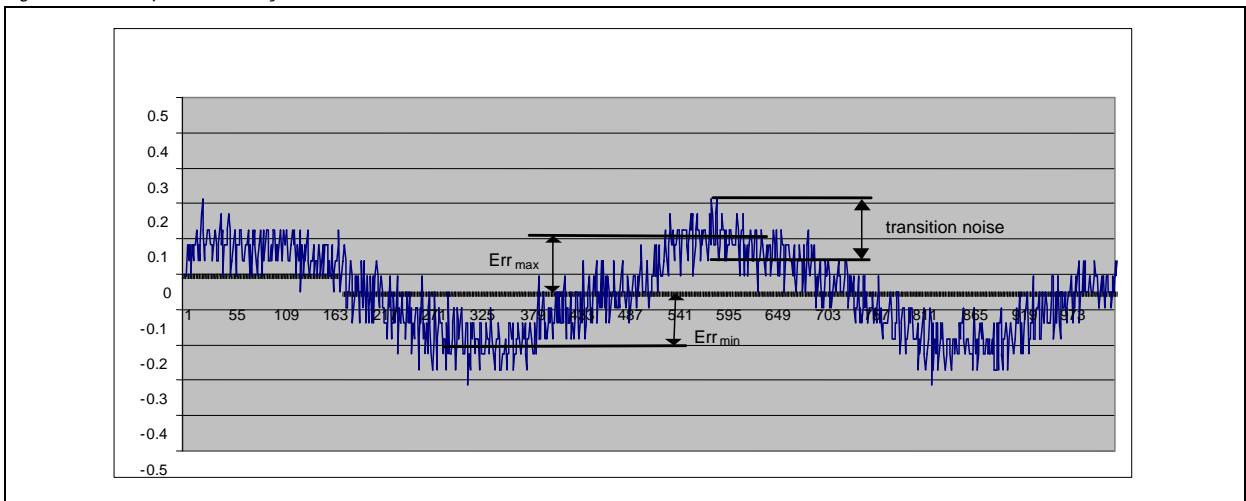



9.6.2 Transition Noise

Transition noise is defined as the jitter in the transition between two steps. Due to the nature of the measurement principle (Hall sensors + Preamplifier + ADC), there is always a certain degree of noise involved. This transition noise voltage results in an angular transition noise at the outputs. It is specified as 0.06 degrees rms (1 sigma)x1 in fast mode (pin MODE = high) and 0.03 degrees rms (1 sigma)x1 in slow mode (pin MODE = low or open).

This is the repeatability of an indicated angle at a given mechanical position. The transition noise has different implications on the type of output that is used:

- **Absolute output; SSI interface:** The transition noise of the absolute output can be reduced by the user by implementing averaging of readings. An averaging of 4 readings will reduce the transition noise by 6dB or 50%, e.g. from 0.03°rms to 0.015°rms (1 sigma) in slow mode.
- **PWM interface:** If the PWM interface is used as an analog output by adding a low pass filter, the transition noise can be reduced by lowering the cutoff frequency of the filter. If the PWM interface is used as a digital interface with a counter at the receiving side, the transition noise can be further reduced by averaging of readings.
- **Incremental mode:** In incremental mode, the transition noise influences the period, width and phase shift of the output signals A, B and Index. However, the algorithm used to generate the incremental outputs guarantees no missing or additional pulses even at high speeds (up to 15,000 rpm and higher).

Note: Statistically, 1 sigma represents 68.27% of readings and 3 sigma represents 99.73% of readings.

9.6.3 High Speed Operation

- **Sampling Rate:** The AS5145 samples the angular value at a rate of 2.61k (slow mode) or 10.42k (fast mode, selectable by pin MODE) samples per second. Consequently, the absolute outputs are updated each 384µs (96µs in fast mode). At a stationary position of the magnet, the sampling rate creates no additional error.
- **Absolute Mode:** At a sampling rate of 2.6kHz/10.4kHz, the number of samples (n) per turn for a magnet rotating at high speed can be calculated by

$$n_{slowmode} = \frac{60}{rpm \cdot (384)\mu s} \quad (EQ 3)$$

$$n_{fastmode} = \frac{60}{rpm \cdot 96\mu s} \quad (EQ 4)$$

The upper speed limit in slow mode is ~6,000 rpm and ~30,000 rpm in fast mode. The only restriction at high speed is that there will be fewer samples per revolution as the speed increases (see Table 7). Regardless of the rotational speed, the absolute angular value is always sampled at the highest resolution of 12-bit.

- **Incremental Mode:** Incremental encoders are usually required to produce no missing pulses up to several thousand rpm. Therefore, the AS5145 has a built-in interpolator, which ensures that there are no missing pulses at the incremental outputs for rotational speeds of up to 15,000 rpm, even at the highest resolution of 12 bits (4096 pulses per revolution).

9.6.4 Propagation Delays

The propagation delay is the delay between the time that the sample is taken until it is converted and available as angular data. This delay is 96µs in fast mode and 384µs in slow mode.

Using the SSI interface for absolute data transmission, an additional delay must be considered, caused by the asynchronous sampling (0 ... 1/ fsample) and the time it takes the external control unit to read and process the angular data from the chip (maximum clock rate = 1MHz, number of bits per reading = 18).

Angular Error Caused by Propagation Delay. A rotating magnet will cause an angular error caused by the output propagation delay.

This error increases linearly with speed:

$$e_{sampling} = rpm * 6 * prop.delay \quad (EQ 5)$$

Where:

esampling = angular error [°]
 rpm = rotating speed [rpm]
 prop.delay = propagation delay [seconds]

Note: Since the propagation delay is known, it can be automatically compensated by the control unit processing the data from the AS5145.



9.6.5 Internal Timing Tolerance

The AS5145 does not require an external ceramic resonator or quartz. All internal clock timings for the AS5145 are generated by an on-chip RC oscillator. This oscillator is factory trimmed to $\pm 5\%$ accuracy at room temperature ($\pm 10\%$ over full temperature range). This tolerance influences the ADC sampling rate and the pulse width of the PWM output:

- Absolute output; SSI interface: A new angular value is updated every $96\mu\text{s}$ (typ) in fast mode and every $384\mu\text{s}$ (typ) in slow mode.
- PWM output: A new angular value is updated every $384\mu\text{s}$ (typ). The PWM pulse timings T_{on} and T_{off} also have the same tolerance as the internal oscillator. If only the PWM pulse width T_{on} is used to measure the angle, the resulting value also has this timing tolerance. However, this tolerance can be cancelled by measuring both T_{on} and T_{off} and calculating the angle from the duty cycle (see [Pulse Width Modulation \(PWM\) Output on page 17](#))

$$\text{Position} = \frac{t_{\text{on}} \cdot 4097}{(t_{\text{on}} + t_{\text{off}})} - 1 \quad (\text{EQ } 6)$$

9.6.6 Temperature

Magnetic Temperature Coefficient. One of the major benefits of the AS5145 compared to linear Hall sensors is that it is much less sensitive to temperature. While linear Hall sensors require a compensation of the magnet's temperature coefficients, the AS5145 automatically compensates for the varying magnetic field strength over temperature. The magnet's temperature drift does not need to be considered, as the AS5145 operates with magnetic field strengths from $\pm 45 \dots \pm 75\text{mT}$.

Example: A NdFeB magnet has a field strength of 75mT @ -40°C and a temperature coefficient of -0.12% per Kelvin. The temperature change is from -40° to $+125^\circ = 165\text{K}$. The magnetic field change is: $165 \times -0.12\% = -19.8\%$, which corresponds to 75mT at -40°C and 60mT at 125°C .

The AS5145 can compensate for this temperature related field strength change automatically, no user adjustment is required.

9.6.7 Accuracy over Temperature

The influence of temperature in the absolute accuracy is very low. While the accuracy is less than or equal to $\pm 0.5^\circ$ at room temperature, it can increase to less than or equal to $\pm 0.9^\circ$ due to increasing noise at high temperatures.

Timing Tolerance over Temperature. The internal RC oscillator is factory trimmed to $\pm 5\%$. Over temperature, this tolerance can increase to $\pm 10\%$. Generally, the timing tolerance has no influence in the accuracy or resolution of the system, as it is used mainly for internal clock generation.

The only concern to the user is the width of the PWM output pulse, which relates directly to the timing tolerance of the internal oscillator. This influence however can be cancelled by measuring the complete PWM duty cycle instead of just the PWM pulse.

9.7 Differences between AS5145H, AS5145A and AS5145B

Table 15. Functional Differences

Function	AS5145H	AS5145A	AS5145B
Filtering mode	Selectable by customer via Mode pin (see Table 7)	Pre-defined to Fast mode	
Mode_Index pin	Input. Must be set hard wired on PCB	Output	Output
Incremental mode setting	Default disabled. Can be enabled by customer via programming	Pre-defined to 2×256 ppr low-jitter (10-bit)	Pre-defined to 2×1024 ppr (12-bit)
Resolution absolute angle output (PWM and SSI)	12-bit angle		



10 Package Drawings and Markings

The device is available in SSOP 16 (5.3mm x 6.2mm).

Figure 22. Package Drawings and Dimensions

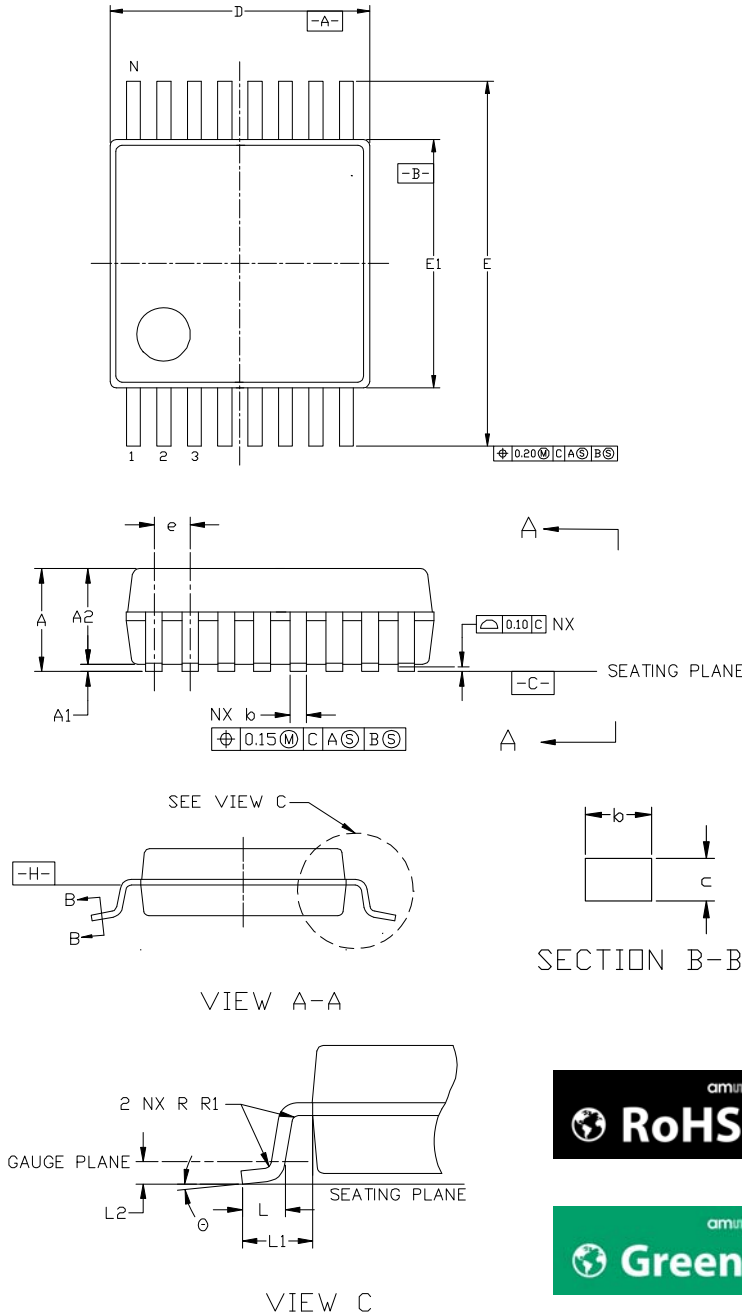

Symbol	Min	Nom	Max
A	1.73	1.86	1.99
A1	0.05	0.13	0.21
A2	1.68	1.73	1.78
b	0.22	0.315	0.38
c	0.09	0.17	0.25
D	5.90	6.20	6.50
E	7.40	7.80	8.20
E1	5.00	5.30	5.60
e	-	0.65 BSC	-
L	0.55	0.75	0.95
L1	-	1.25 REF	-
L2	-	0.25 BSC	-
R	0.09	-	-
Θ	0°	4°	8°
N	16		



Notes:

1. Dimensions and tolerancing conform to *ASME Y14.5M-1994*.
2. All dimensions are in millimeters. Angles are in degrees.

Marking: YYWWMZZ.

YY	WW	M	ZZ
Last two digits of the manufacturing year	Manufacturing week	Plant identifier	Assembly traceability code



Figure 23. Vertical Cross Section of SSOP-16

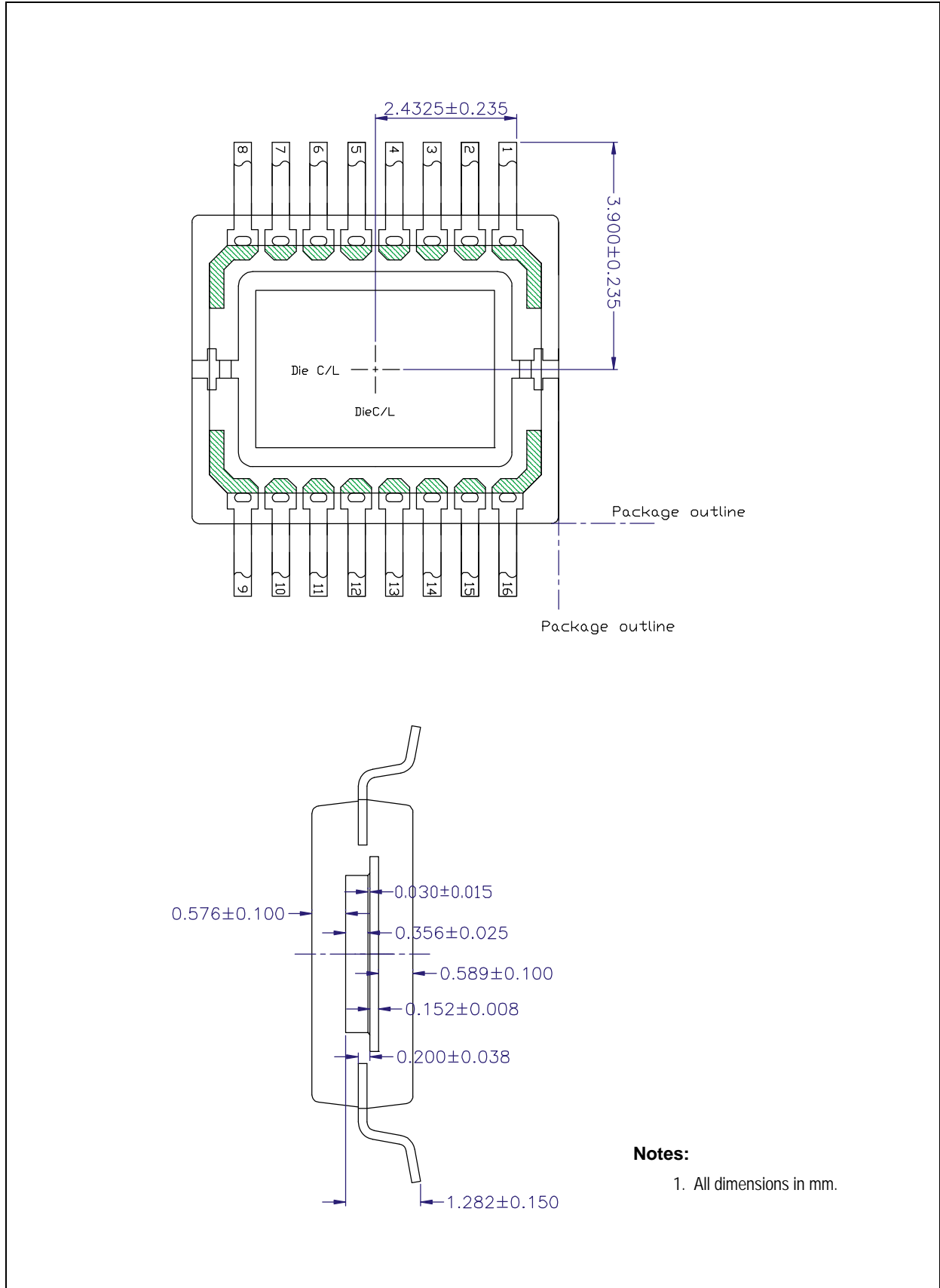



10.1 Recommended PCB Footprint

Figure 24. PCB Footprint

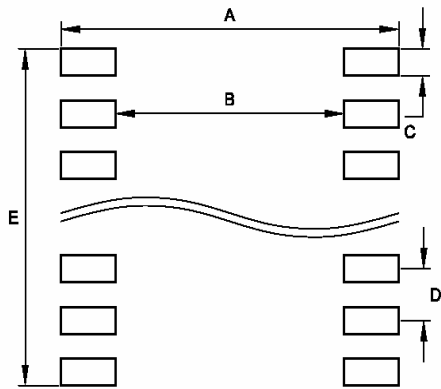

Recommended Footprint Data	
Symbol	mm
A	9.02
B	6.16
C	0.46
D	0.65
E	5.01



Revision History

Revision	Date	Owner	Description
1.1	May 30, 2008	apg	Changed the temperature to 150°C across the datasheet.
	Jul 23, 2008		Added Key Feature: Fully automotive qualified to AEC-Q100, grade 0
	Jul 25, 2008		Changed the values in Table 10 for 10-bit and 12-bit incremental mode
1.2	Aug 24, 2008	rfu	Inserted 10kΩ for pin 6 in Table 1
			changed values for fmag_abs in Table 4
			Made changes to Incremental Mode on page 14 .
			Removed quadrature from Figure 6 .
			Inserted Incremental Output Hysteresis on page 15 and Figure .
			Modified the typ value of all in Table 11 .
1.3	Aug 27, 2008	rfu	changed the values in equation2 (page 18)
			Modified Applications
1.4	Sep 29, 2008	apg	Removed table Magnetic field strength variation indicator and modified Table 9 cell headings
			Changed angle position values in Pulse Width Modulation (PWM) Output on page 17 and also update Table 6 for the same.
	Feb 13, 2009		Changed the value of tDovaid in Table 6
	Feb 16, 2009		Changed the value of PW _{MIN} , PW _{MAX} in Table 6
	Feb 18, 2009	mub	Updated Figure 14 with 2.2μF capacitor without polarity
			Updated Figure 17 with 2.2μF instead of 2.2μF...10μF
			Changed key feature: Added pre-programmed versions available
Feb 22, 2009	apg	Removed 10 bit from pin descriptions for pin 12 on page 4	
		Deleted Min value for tDovaid in Table 6	
1.5	Jul 15, 2009	rfu	updated ordering information
			Changed the Max value of tDovaid in Table 6 to 413
1.6	Jul 15, 2009	rfu	Added "AS5145-I10/AS5145-I12" to the header
			Made some sentence corrections and spelling mistakes
1.7	Aug 12, 2009	apg	Updated Incremental Mode on page 14 with new information.
1.8	Sep 29, 2009	rfu	Added a note to the ordering information
1.9	Nov 05, 2009	apg	Updated Figure 13
			Added Incremental Power-up Lock Option on page 15
1.10	Dec 04, 2009	apg	Updated section Timing Characteristics (page 11) - Updated the parameter 'PWM Frequency' (f _{PWM})
1.11	Jun 16, 2010	mub	Updated section Internal Timing Tolerance (page 29)
	Jun 25, 2010	apg	Updated Table 1 , Table 3 , Table 6
1.12	Nov 09, 2011	ach	Updated device header and Ordering Information (page 35)
1.13	Nov 25, 2011	ekno	Updated maximum rotation speed in incremental mode (see page 28)
1.14	Feb 29, 2012		Updated MSL in Absolute Maximum Ratings and Package Drawings and Markings .
			Updated Figure 23 and carried out sentence structure related changes across datasheet.



Revision	Date	Owner	Description
1.15	Jul 23, 2012	mub	Added comparison table (page 29), Updated storage temp. values.
1.16	Oct 16, 2012		Updated Table 5 and ams logos.
1.17	Jul 04, 2013		Ordering Version Tube removed. Figure 4 replaced by new picture.



11 Ordering Information

The devices are available as the standard products shown in [Table 16](#).

Table 16. Ordering Information

Ordering Code	Description	Delivery Form	Package
AS5145H-HSST	12-Bit Programmable Magnetic Rotary Encoder	Tape & Reel	SSOP 16 (5.3mm x 6.2mm)
AS5145A-HSST	Pre-programmed 10-bit incremental	Tape & Reel	
AS5145B-HSST	Pre-programmed 12-bit incremental	Tape & Reel	

Note: All products are RoHS compliant and ams green.
Buy our products or get free samples online at www.ams.com/ICdirect

Technical Support is available at www.ams.com/Technical-Support

For further information and requests, email us at sales@ams.com
(or) find your local distributor at www.ams.com/distributor



Copyrights

Copyright © 1997-2013, ams AG, Tobelbaderstrasse 30, 8141 Unterpremstaetten, Austria-Europe. Trademarks Registered ®. All rights reserved. The material herein may not be reproduced, adapted, merged, translated, stored, or used without the prior written consent of the copyright owner.

All products and companies mentioned are trademarks or registered trademarks of their respective companies.

Disclaimer

Devices sold by ams AG are covered by the warranty and patent indemnification provisions appearing in its Term of Sale. ams AG makes no warranty, express, statutory, implied, or by description regarding the information set forth herein or regarding the freedom of the described devices from patent infringement. ams AG reserves the right to change specifications and prices at any time and without notice. Therefore, prior to designing this product into a system, it is necessary to check with ams AG for current information. This product is intended for use in normal commercial applications. Applications requiring extended temperature range, unusual environmental requirements, or high reliability applications, such as military, medical life-support or life-sustaining equipment are specifically not recommended without additional processing by ams AG for each application. For shipments of less than 100 parts the manufacturing flow might show deviations from the standard production flow, such as test flow or test location.

The information furnished here by ams AG is believed to be correct and accurate. However, ams AG shall not be liable to recipient or any third party for any damages, including but not limited to personal injury, property damage, loss of profits, loss of use, interruption of business or indirect, special, incidental or consequential damages, of any kind, in connection with or arising out of the furnishing, performance or use of the technical data herein. No obligation or liability to recipient or any third party shall arise or flow out of ams AG rendering of technical or other services.



Contact Information

Headquarters

ams AG
Tobelbaderstrasse 30
A-8141 Unterpremstaetten, Austria

Tel : +43 (0) 3136 500 0
Fax : +43 (0) 3136 525 01

For Sales Offices, Distributors and Representatives, please visit:

<http://www.ams.com/contact>