

2-Input 1-Output Video Switch (W/75Ω driver)/3-Input 1-Output Video Switch (W/75Ω driver)

Monolithic IC MM1221~MM1228

November 2, 2001

Outline

These ICs are high-end video switch ICs with 2-input 1-output or 3-input 1-output including a 75Ω driver. The series includes those with and without a built-in clamp circuit and a 6dB amp.

The circuit configuration table and block diagram are shown below.

MM1228 is introduced as a representative model in this document.

MM1221~MM1228 Series Circuit Configuration Table

Model name	# of Inputs	# of Outputs	6dB amp circuit	Clamp circuit	Power supply voltage range
MM1221	2	1	No	No	8~13V
MM1222	2	1	Yes	No	8~13V
MM1223	3	1	No	No	8~13V
MM1224	3	1	Yes	No	8~13V
MM1225	2	1	No	Yes	4.7~13V
MM1226	2	1	Yes	Yes	4.7~13V
MM1227	3	1	No	Yes	4.7~13V
MM1228	3	1	Yes	Yes	4.7~13V

www.Datasheet4.com

MM1221~MM1228 Input/Output Voltage Measurement Values (typ.)

Model name	Power supply voltage	5V	9V	12V	Unit
MM1221	Input voltage		4.53	6.05	V
	Output voltage		4.5	6.1	V
MM1222	Input voltage		4.05	5.4	V
	Output voltage		5.34	7.12	V
MM1223	Input voltage		4.53	6.05	V
	Output voltage		4.5	6.1	V
MM1224	Input voltage		4.05	5.4	V
	Output voltage		5.34	7.12	V
MM1225	Input voltage	1.27	2.17	2.86	V
	Output voltage	1.31	2.25	2.96	V
MM1226	Input voltage	1.3	2.2	2.9	V
	Output voltage	1.4	2.23	2.88	V
MM1227	Input voltage	1.27	2.17	2.86	V
	Output voltage	1.31	2.25	2.96	V
MM1228	Input voltage	1.3	2.2	2.9	V
	Output voltage	1.4	2.23	2.88	V

Block Diagram (MM1221~MM1228)

MM1221

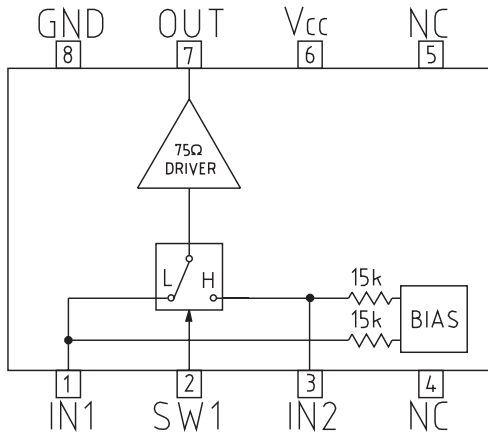

Control input truth table

SW	OUT
L	IN1
H	IN2

MM1222

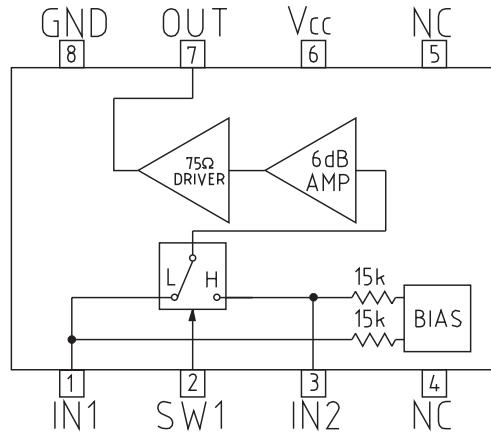

Control input truth table

SW	OUT
L	IN1
H	IN2

MM1223

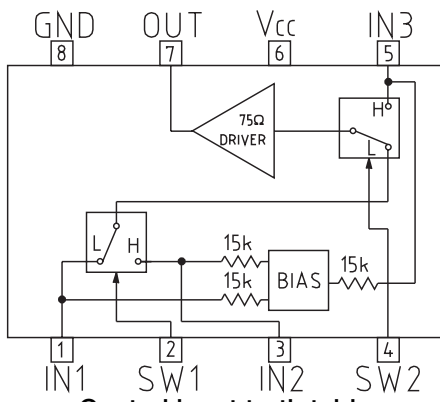

Control input truth table

SW1	SW2	OUT
L	L	IN1
H	L	IN2
L/H	H	IN3

MM1224

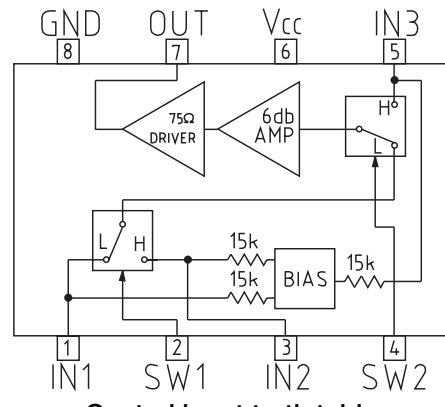

Control input truth table

SW1	SW2	OUT
L	L	IN1
H	L	IN2
L/H	H	IN3

MM1225

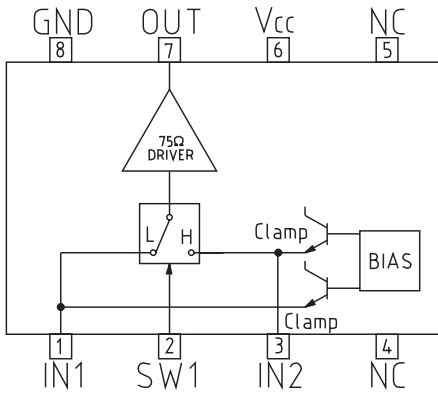

Control input truth table

SW	OUT
L	IN1
H	IN2

MM1226

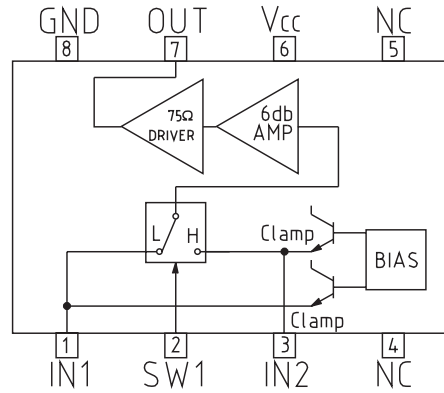

Control input truth table

SW	OUT
L	IN1
H	IN2

MM1227

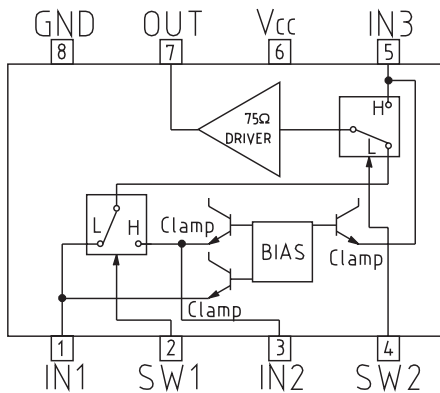

Control input truth table

SW1	SW2	OUT
L	L	IN1
H	L	IN2
L/H	H	IN3

MM1228

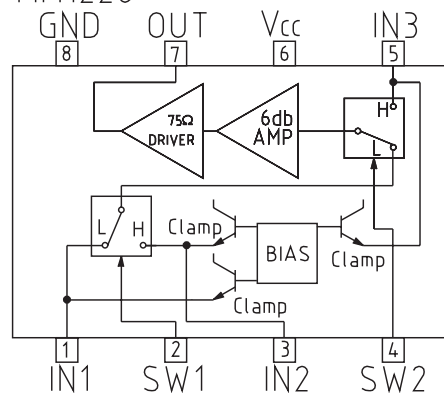

Control input truth table

SW1	SW2	OUT
L	L	IN1
H	L	IN2
L/H	H	IN3

Introduction of Main Model

3-Input 1-Output Video Switch (with 75Ω driver, clamp and 6dB amp) Monolithic IC MM1228

November 2, 2001

Outline

This is a high performance 3-input 1-output video switch IC with 6dB amp, clamp and 75Ω driver circuits. 1V_{P-P} video signals can be output externally with 75Ω output.

Features

1. Built-in 75Ω driver circuit
2. Built-in 6dB amp
3. Built-in clamp circuit
4. Models in the MM1221~MM1228 series without a clamp circuit can support audio or chroma circuits
5. Mute operation possible
6. Wide operating supply voltage range 4.7~13V
7. Low current consumption
8. Wideband frequency response 7MHz at 0dB
9. Crosstalk -64dB (4.43MHz)

Packages

SOP-8C (MM1228XF)

Applications

1. TV
2. VCR
3. Video cameras
4. Other video equipment

Block Diagram

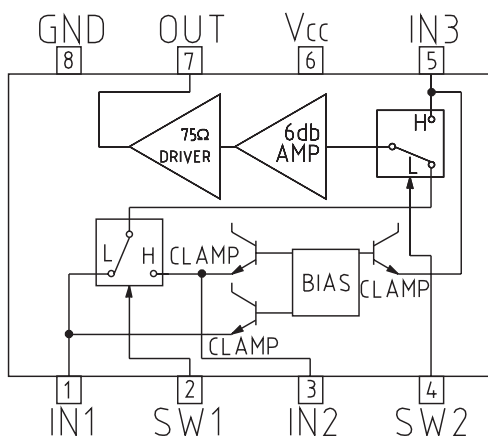

Control input truth table

SW1	SW2	OUT
L	L	IN1
H	L	IN2
L/H	H	IN3

Pin Description

Pin no.	Pin name	Function	Internal equivalent circuit diagram
1 3 5	IN1 IN2 IN3	Input	
2 4	SW1 SW2	Switch	
7	OUT	Output	
6	Vcc	Power supply	
8	GND	Ground	

Measuring Circuit

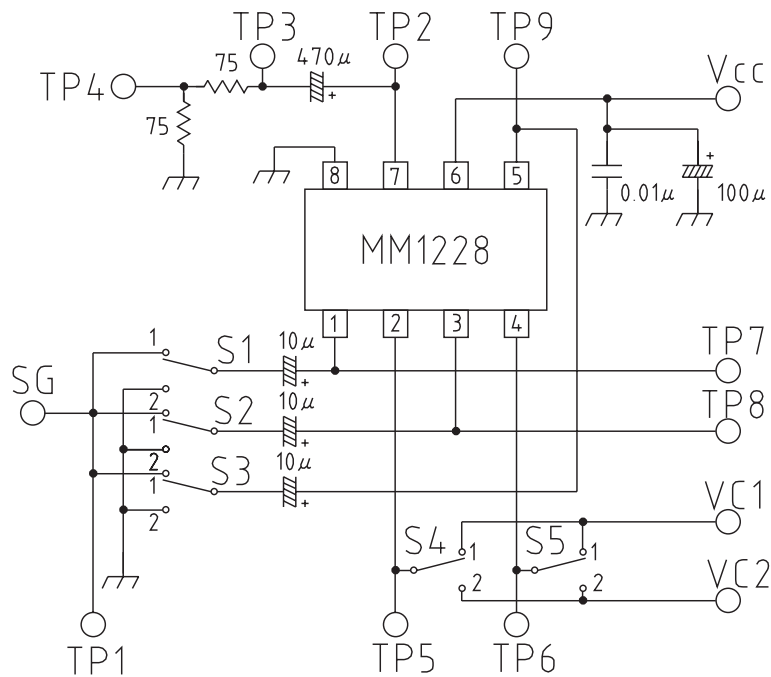

Absolute Maximum Ratings (Ta=25°C)

Item	Symbol	Ratings	Units
Storage temperature	T _{STG}	-40~+125	°C
Operating temperature	T _{OPR}	-20~+75	°C
Power supply voltage	V _{CC}	15	V
Allowable loss	P _d	300	mW

Electrical Characteristics (Except where noted otherwise, Ta=25°C, V_{CC}=5.0V)

Item	Symbol	Measurement conditions	Min.	Typ.	Max.	Units
Operating power supply voltage range	V _{CC}		4.7		13.0	V
Consumption current	I _d	Refer to Measuring Circuit		8.4	10.9	mA
Voltage gain	G _v	Refer to Measuring Circuit	+5.5	+6.0	+6.5	dB
Frequency characteristic	F _c	Refer to Measuring Circuit	-1	0	+1	dB
Differential gain	DG	Refer to Measuring Circuit		0	±3	%
Differential phase	DP	Refer to Measuring Circuit		0	±3	deg
Output offset voltage	V _{off}	Refer to Measuring Circuit			±30	mV
Crosstalk	C _T	Refer to Measuring Circuit		-64	-54	dB
SW1 input voltage H	V _{IH1}	Refer to Measuring Circuit	2.1			V
SW1 input voltage L	V _{IL1}	Refer to Measuring Circuit			0.7	V
SW2 input voltage H	V _{IH2}	Refer to Measuring Circuit	2.1			V
SW2 input voltage L	V _{IL2}	Refer to Measuring Circuit			0.7	V

Measuring Procedures ($V_{CC}=5.0V$, $VC1=V_{CC}$, $VC2=0V$)

Item	Symbol	Switch state					Measuring Procedure
		S1	S2	S3	S4	S5	
Consumption current	Id	2	2	2	2	2	Connect a DC ammeter to the Vcc pin and measure. The ammeter is shorted for use in subsequent measurements.
Voltage gain	Gv	1	2	2	2	2	Input a 1.0V _{P-P} , 100kHz sine wave to SG, and obtain G _v from the following formula given TP1 voltage as V1 and TP3 voltage as V2. $G_v=20\text{LOG} (V_2/V_1)$ dB
		2	1	2	1	2	
		2	2	1	1	1	
		2	2	1	2	1	
Frequency characteristic	Fc	1	2	2	2	2	For the above G _v measurement, given TP3 voltage for 7MHz as V3, F _c is obtained from the following formula. $F_c=20\text{LOG} (V_3/V_2)$ dB
		2	1	2	1	2	
		2	2	1	1	1	
		2	2	1	2	1	
Differential gain	DG	1	2	2	2	2	Input a 1.0V _{P-P} staircase wave to SG, and measure differential gain at TP4. APL=10~90%
		2	1	2	1	2	
		2	2	1	1	1	
		2	2	1	2	1	
Differential phase	DP	1	2	2	2	2	Proceed as for DG, and measure differential phase.
		2	1	2	1	2	
		2	2	1	1	1	
		2	2	1	2	1	
Output offset voltage	Voff	2	2	2	2	2	Measure the DC voltage difference of each switch status at TP2.
		2	2	2	1	2	
		2	2	2	1	1	
Crosstalk	CT	1	2	2	1	2	Assume VC1=2.1V, VC2=0.7V. Input a 1.0V _{P-P} , 4.43MHz sine wave to SG, and given TP1 voltage as V4 and TP3 voltage as V5, C _T is obtained from the following formula. $C_T=20\text{LOG} (V_5/V_4)$ dB
		1	2	2	2	1	
		1	2	2	1	1	
		2	1	2	2	2	
		2	1	2	2	1	
		2	1	2	1	1	
		2	2	1	2	2	
Switch 1 input voltage H	VIH1	2	2	2	1	2	Impress an optional DC voltage on TP7 and TP8. Gradually raise from VC1=0V. TP5 voltage when TP8 voltage is output on TP2 is VIH1. Gradually lower from VC1=VCC. TP5 voltage when TP7 voltage is output on TP2 is VIL1.
Switch 1 input voltage L	VIL1						
Switch 2 input voltage H	VIH2	2	2	2	2	1	Impress an optional DC voltage on TP7 and TP9. Gradually raise from VC1=0V. TP5 voltage when TP9 voltage is output on TP2 is VIH2. Gradually lower from VC1=VCC. TP6 voltage when TP7 voltage is output on TP2 is VIL2.
Switch 2 input voltage L	VIL2						