

■ Features

- Low gate charge
 $Q_G = 26 \text{ nC TYP. (} V_{DD} = 320 \text{ V, } V_{GS} = 10 \text{ V, } I_D = 10 \text{ A)}$
- Gate voltage rating: $\pm 30 \text{ V}$
- Low on-state resistance
 $R_{DS(on)} = 0.55 \ \Omega \text{ MAX. (} V_{GS} = 10 \text{ V, } I_D = 5.0 \text{ A)}$
- Surface mount package available

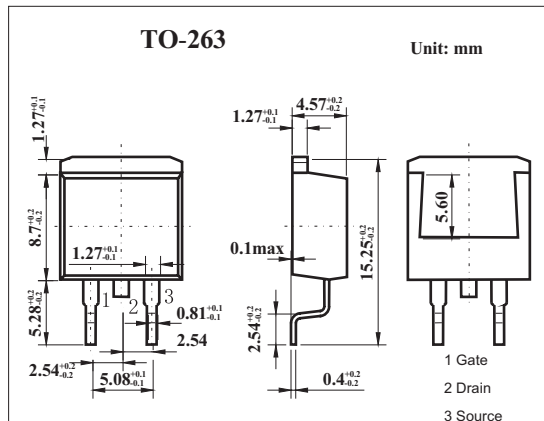

■ Absolute Maximum Ratings $T_a = 25^\circ\text{C}$

Parameter	Symbol	Rating	Unit
Drain to source voltage	V_{DSS}	400	V
Gate to source voltage	V_{GSS}	± 30	V
Drain current	I_D	± 10	A
	I_{dp}^*	± 34	A
Power dissipation	P_D	$T_A=25^\circ\text{C}$	1.5
		$T_c=25^\circ\text{C}$	100
Channel temperature	T_{ch}	150	$^\circ\text{C}$
Storage temperature	T_{stg}	-55 to +150	$^\circ\text{C}$

* $PW \leq 10 \ \mu\text{s, Duty Cycle} \leq 1\%$

■ Electrical Characteristics $T_a = 25^\circ\text{C}$

Parameter	Symbol	Testconditions	Min	Typ	Max	Unit	
Drain cut-off current	I_{DSS}	$V_{DS}=400\text{V, } V_{GS}=0$			10	μA	
Gate leakage current	I_{GSS}	$V_{GS} = \pm 30\text{V, } V_{DS}=0$			± 100	nA	
Gate cut off voltage	$V_{GS(off)}$	$V_{DS}=10\text{V, } I_D=1\text{mA}$	2.5		3.5	V	
Forward transfer admittance	$ Y_{fs} $	$V_{DS}=10\text{V, } I_D=5.0\text{A}$	3.0	5.6		S	
Drain to source on-state resistance	$R_{DS(on)1}$	$V_{GS}=10\text{V, } I_D=5.0\text{A}$		0.4	0.55	Ω	
Input capacitance	C_{iss}	$V_{DS}=10\text{V, } V_{GS}=0, f=1\text{MHZ}$		1320		pF	
Output capacitance	C_{oss}				230		pF
Reverse transfer capacitance	C_{rss}				13		pF
Turn-on delay time	t_{on}	$I_D=5.0\text{A, } V_{GS(on)}=10\text{V, } R_G=10 \ \Omega, V_{DD}=150\text{V}$		18		ns	
Rise time	t_r			8		ns	
Turn-off delay time	t_{off}				44		ns
Fall time	t_f				4		ns
Total Gate Charge	Q_G	$V_{DD} = 320\text{V}$ $V_{GS} = 10 \text{ V}$ $I_D = 10\text{A}$		26		nC	
Gate to Source Charge	Q_{GS}			7		nC	
Gate to Drain Charge	Q_{GD}			11		nC	
Body Diode Forward Voltage	$V_{F(S-D)}$	$I_F = 10 \text{ A, } V_{GS} = 0 \text{ V}$		0.9		V	
Reverse Recovery Time	t_{rr}	$I_F = 10 \text{ A, } V_{GS} = 0 \text{ V}$ $di/dt = 100 \text{ A/} \mu\text{s}$		350		ns	
Reverse Recovery Charge	Q_{rr}				2.7		μC