

SCA610 Series

Accelerometer/Inclinometer

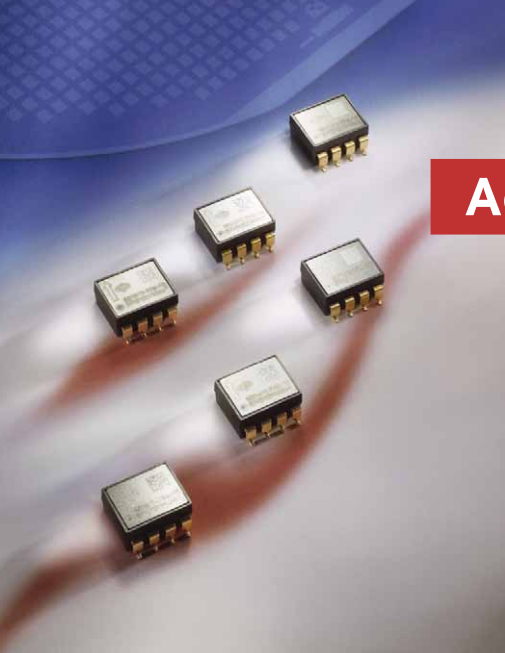

FEATURES

- Available ranges $\pm 0.5\text{ g}$ ($\pm 30^\circ$), $\pm 1\text{ g}$ ($\pm 90^\circ$), $\pm 1.5\text{ g}$, $\pm 1.7\text{ g}$, $\pm 3.0\text{ g}$
- 8-pin plastic surface mount DIP package mountable with pick and place machines
- Enhanced failure detection
- Digitally activated electrostatic self test (not for inclinometers)
- Calibration memory parity check
- Continuous connection failure detection
- Bi-directional acceleration measurement
- Controlled frequency response in the sensing element
- Single +5 V supply; ratiometric voltage output in the range 4.75 ... 5.25 V
- Lead-free reflow solderable lead-free component

BENEFITS

- Exceptional reliability, unprecedented accuracy and excellent stability over temperature and time
- Outstanding overload and shock durability
- No additional components required

APPLICATIONS

- Acceleration measurement
- Inclination measurement
- Motion measurement
- Vibration measurement

For customised product please contact VTI Technologies

ELECTRICAL CHARACTERISTICS

Parameter	Condition	Min.	Typ.	Max.	Units
Supply voltage Vdd		4.75		5.25	V
Current consumption	Vdd = 5 V; No load		2.0	4.0	mA
Operating temperature		-40		+125	°C
Resistive output load	Vout to Vdd or Vss	20			kOhm
Capacitive load	Vout to Vdd or Vss			20	nF
Output noise ⁽¹⁾	DC...4 kHz			5	mVrms

PERFORMANCE CHARACTERISTICS

Parameter	Condition/Comment	SCA610-CAHH1G ⁽¹³⁾	SCA610-CAIH1G ⁽¹³⁾	SCA610-C2IH1A	SCA610-C23H1A	SCA610-C28H1A	SCA610-C13H1A	SCA610-CC5H1A	Units
Measuring range ⁽²⁾	Nominal	± 0.5 ($\pm 30^\circ$)	± 1 ($\pm 90^\circ$)	± 1	± 1.5	± 1.7	± 1.5	± 3	g
Mounting plane ⁽³⁾	Measuring Direction	Horizontal	Horizontal	Horizontal	Horizontal	Horizontal	Horizontal	Horizontal	
Zero point (nom.) ⁽⁴⁾	Mounting position	Vdd/2	Vdd/2	Vdd/2	Vdd/2	Vdd/2	Vdd/2	Vdd/2	V
Sensitivity	@ room temperature	4 ^(5b)	2 ^(5a)	2 ^(5a)	1.333 ^(5a)	1.2 ^(5a)	1.33 ^(5a)	0.75 ^(5a)	V/g
Zero Point error ⁽⁶⁾	-40...125 °C	± 50	± 50	± 125	± 125	± 125	± 125	± 195	mg
Sensitivity error	-40...125 °C	± 4 ^(8b)	± 4 ^(8a)	± 5 ^(8a)	± 5 ^(8a)	± 5 ^(8a)	± 5 ^(8a)	± 5 ^(8a)	%
Sensitivity error ⁽⁷⁾	-25...85 °C	± 2.5 ^(8b)	± 2.5 ^(8a)	± 3 ^(8a)	± 3 ^(8a)	± 3 ^(8a)	± 3 ^(8a)	± 3 ^(8a)	%
Typical non-linearity ⁽⁷⁾	Over measuring range	± 10 ^(9b, c)	± 10 ^(9a, c)	± 20 ^(9a)	± 20 ^(9a)	± 20 ^(9a)	± 20 ^(9a)	± 60 ^(9a)	mg
Cross-axis sensitivity ⁽¹⁰⁾		5	5	4	4	4	4	4	%
Frequency response	-3dB point ⁽¹¹⁾	18 \pm 10	18 \pm 10	50 \pm 30	50 \pm 30	50 \pm 30	400 \pm 150	115 \pm 55	Hz
Ratiometric error ⁽¹²⁾	Vdd = 4.75...5.25 V	2	2	2	2	2	2	2	%

VDD = 5.00 V, UNLESS OTHERWISE SPECIFIED

Note 1 The noise density of CAHH1G and CAIH1G is 30 $\mu\text{g}/\sqrt{\text{Hz}}$, the noise density of C23H1A and C28H1A is 20 $\mu\text{g}/\sqrt{\text{Hz}}$.

Note 2 The measuring range is limited by sensitivity, offset and supply voltage rails of the device.

Note 3 Measuring direction parallel to the mounting plane.

Note 4 Vertical versions in +1 g position, i.e. arrow up: horizontal versions pins down (+0 g)

Note 5a Sensitivity specified as $[V_{\text{out}}(+1\text{ g}) - V_{\text{out}}(-1\text{ g})] / 2$ [V/g].

Note 5b Sensitivity specified as $[V_{\text{out}}(+0.5\text{ g}) - V_{\text{out}}(-0.5\text{ g})] / 2$ [V/g].

Note 6 Zero point error specified as $(V_{\text{out}}(+0\text{ g}) - V_{\text{dd}}/2) / V_{\text{sens}}$ [g] (room temp. error included); V_{sens} = Nominal sensitivity.

Note 7 Typical tolerance, not 100 % tested.

Note 8a Sensitivity error specified as $\{([V_{\text{out}}(+1\text{ g}) - V_{\text{out}}(-1\text{ g})] / 2) - V_{\text{sens}}\} / V_{\text{sens}} \times 100$ [%] (room temp. error included); V_{sens} = Nominal sensitivity.

Note 8b Sensitivity error specified as $\{([V_{\text{out}}(+0.5\text{ g}) - V_{\text{out}}(-0.5\text{ g})] / 2) - V_{\text{sens}}\} / V_{\text{sens}} \times 100$ [%] (room temp. error included); V_{sens} = Nominal sensitivity.

Note 9a Relative to straight line between $\pm 1\text{ g}$.

Note 9b Relative to straight line between $\pm 0.5\text{ g}$.

Note 9c In inclinometer applications a correction based on the angular error resulting from cross-axis sensitivity around the inclination angle reduces non-linearity.

Note 10 The cross-axis sensitivity determines how much acceleration, perpendicular to the measuring axis, couples to the output. The total cross-axis sensitivity is the geometric sum of the sensitivities of the two axes, which are perpendicular to the measuring axis.

Note 11 The output has true DC (0 Hz) response.

Note 12 Supply voltage noise also couples to the output, due to the ratiometric (output proportional to supply voltage) nature of the accelerometer.

Note 13 Self test not recommended.

The ratiometric error is specified as:
$$RE = 100\% \times \left(1 - \frac{V_{\text{out}}(@V_x) \times \frac{5.00V}{V_x}}{V_{\text{out}}(@5V)} \right)$$

ABSOLUTE MAXIMUM RATINGS

Parameter	Value	Units
Acceleration (powered or non-powered)	20000	g
Supply voltage	-0.3 to +7.0	V
Voltage at input / output pins	-0.3 to Vdd + 0.3	V
Temperature range	-55 to +125	°C

ELECTRICAL CONNECTION

Pin#	Pin Name	Connection
1		Open or capacitively connected to GND for EMC*
2		Open or capacitively connected to GND for EMC*
3		Open or capacitively connected to GND for EMC*
4	GND	Negative supply voltage (VSS)
5		Open or capacitively connected to GND for EMC*
6	ST	Self-test control
7	VOUT	Sensor analog output
8	VDD	Positive supply voltage (VDD)

*) recommended capacity min. 20 pF - Effectiveness should be tested and if necessary adapted in the respective connection.

RECOMMENDED CIRCUIT

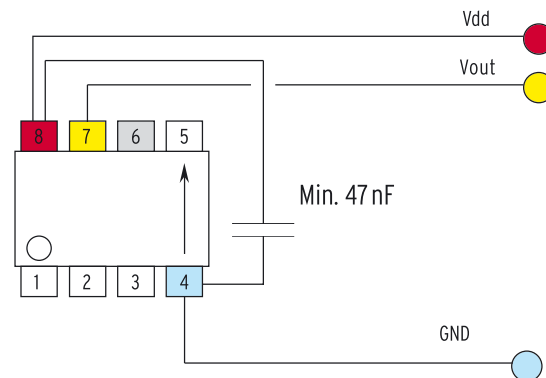

DIMENSIONS

The accelerometer weighs under 1 g.
The size of the part is approximately (w x h x l) 9 x 5 x 11 mm. Pin pitch is standard 100 mils.

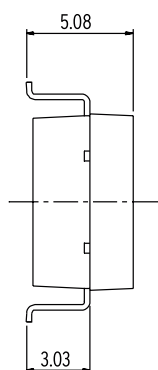
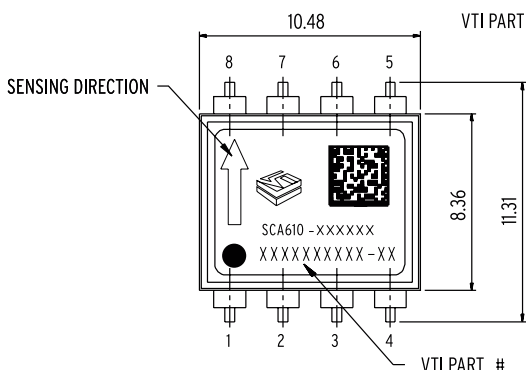

PCB PAD LAYOUTS

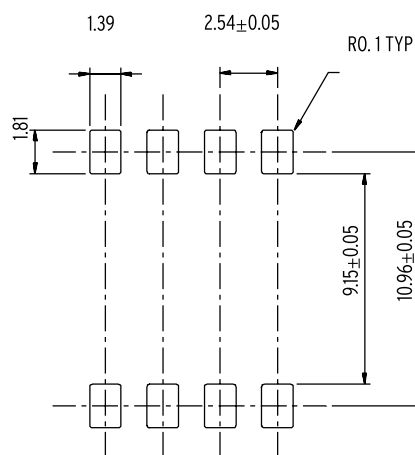

Acceleration in the direction of the arrow will increase the output voltage.