

Circuits from the Lab™ Reference Circuits

Circuits from the Lab™ reference circuits are engineered and tested for quick and easy system integration to help solve today's analog, mixed-signal, and RF design challenges. For more information and/or support, visit www.analog.com/CN0267.

Devices Connected/Referenced

| | |
|----------|---|
| ADuCM360 | Low Power, Precision Analog Microcontroller |
| AD5421 | 16-Bit, Loop Powered, 4 mA to 20 mA DAC |
| AD5700 | Low Power HART Modem |

Complete 4 mA to 20 mA Loop Powered Field Instrument with HART Interface

EVALUATION AND DESIGN SUPPORT

Circuit Evaluation Board

[CN0267 Circuit Evaluation Board \(DEMO-AD5700D2Z\)](#)

Design and Integration Files

[Schematics](#), [Layout Files](#), [Bill of Materials](#), [Code Example](#)

CIRCUIT FUNCTION AND BENEFITS

The circuit shown in Figure 1 is a complete smart industrial, loop powered field instrument with 4 mA to 20 mA analog output and a highway addressable remote transducer (HART®) interface. HART is a digital 2-way communication in which a 1 mA peak-to-peak frequency-shift-keyed (FSK) signal is modulated on top of the standard 4 mA to 20 mA analog current signal. This allows

features such as remote calibration, fault interrogation, and transmission of process variables, which are necessary in applications such as temperature and pressure control.

This circuit has been compliance tested, verified, and registered by the HART Communication Foundation (HCF). This successful registration provides circuit designers with a high level of confidence using one or all of the components in the circuit.

The circuit uses the ADuCM360, an ultralow power, precision analog microcontroller, the AD5421, a 16-bit, 4 mA to 20 mA, loop powered digital-to-analog converter (DAC), and the AD5700, the industry's lowest power and smallest footprint HART-compliant IC modem.

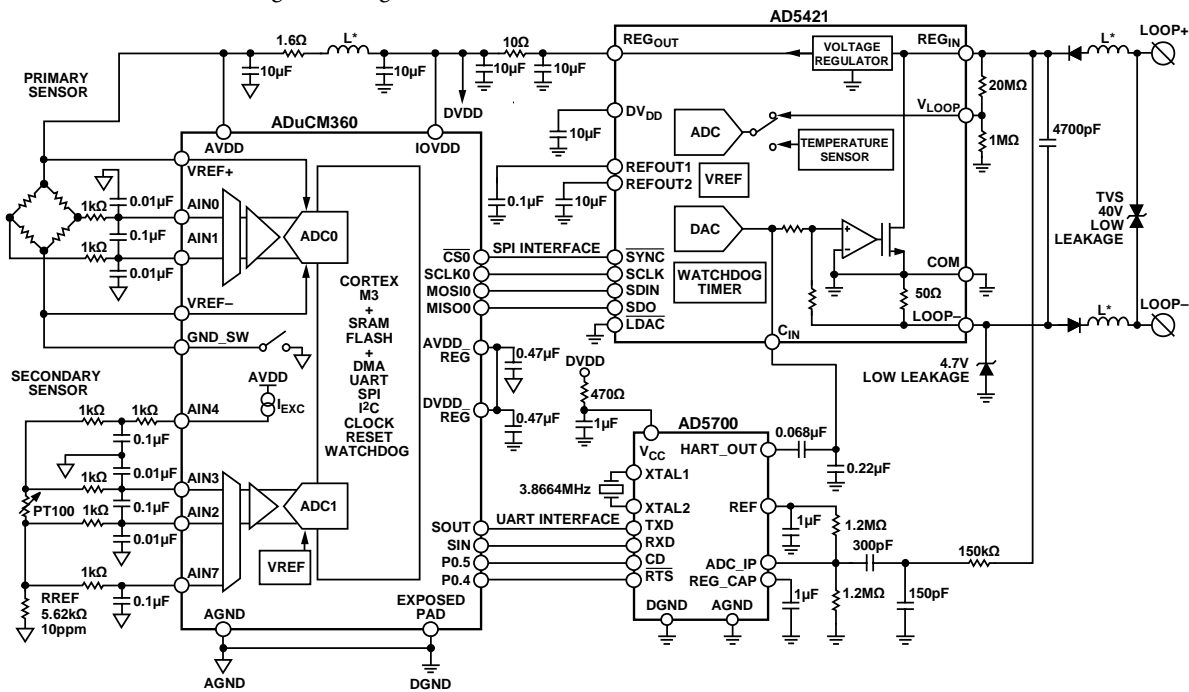

NOTES

1. L* = FERRITE BEAD, 0.3Ω @ DC, 1kΩ @ 100MHz.
2. THE ADuCM360 EXPOSED PAD IS CONNECTED TO DGND.

Figure 1. 4 mA to 20 mA, Loop Powered Field Instrument with HART Interface (Simplified Schematic: All Connections and Decoupling Not Shown)

Rev. A

Circuits from the Lab™ circuits from Analog Devices have been designed and built by Analog Devices engineers. Standard engineering practices have been employed in the design and construction of each circuit, and their function and performance have been tested and verified in a lab environment at room temperature. However, you are solely responsible for testing the circuit and determining its suitability and applicability for your use and application. Accordingly, in no event shall Analog Devices be liable for direct, indirect, special, incidental, consequential or punitive damages due to any cause whatsoever connected to the use of any Circuits from the Lab circuits. (Continued on last page)

CIRCUIT DESCRIPTION

Analog Front-End Interface

The [ADuCM360](#) analog front-end incorporates dual, high performance 24-bit sigma-delta (Σ - Δ) analog-to-digital converters (ADCs). It also integrates programmable gain instrumentation amplifiers, a precision band-gap reference, programmable current sources, a flexible multiplexer, and many other features. It allows a direct interface to multiple analog sensors, such as pressure sensor bridges, resistive temperature sensors, thermocouples, and many other types of sensors used in the industry.

The circuit in Figure 1 shows an example connection for a primary bridge type sensor and a secondary resistive temperature sensor; however the [ADuCM360](#) flexible front-end allows many other configurations to accommodate any type of precision analog sensor application.

Primary Sensor Input

The [ADuCM360](#) on-chip ADC0 measures the field instrument primary sensor, shown as a bridge transducer in Figure 1. The sensor connects to the analog input pins, AIN0 and AIN1, via an RC filter network for improved system electromagnetic immunity. The common-mode filter bandwidth is approximately 16 kHz, and the differential-mode bandwidth is 800 Hz.

The [ADuCM360](#) VREF+ and VREF- voltage reference inputs sense the bridge excitation voltage and enable the circuit to work in a ratiometric mode, making the measurement independent of the exact value of the sensor power supply voltage. The on-chip ground switch can dynamically disconnect the bridge excitation and save power when required by the application.

Secondary Sensor Input

The circuit uses a platinum (Pt) 100 Ω resistive temperature device (RTD) as a secondary sensor. The RTD can sense the temperature of the primary sensor and thus allow for temperature compensation of the primary sensor if required.

The [ADuCM360](#) programmable current source supplies the RTD via the AIN4 pin. The ADC1 on the [ADuCM360](#) measures the voltage across the RTD using the AIN3 and AIN2 pins configured as a differential input. The exact value of the current flowing through the RTD is sensed by a precision resistor (RREF) and is measured by the ADC1 using the AIN7 pin. The ADC1 uses the on-chip, band-gap voltage reference.

Digital Data Processing, Algorithm, and Communications

All the field instrument digital functions are provided by the [ADuCM360](#) 32-bit ARM Cortex™ M3 RISC processor, with integrated 128 k bytes of nonvolatile flash/EE memory, 8 k bytes of SRAM, and an 11-channel direct memory access (DMA) controller that supports wired (2× SPI, UART, I²C) communication peripherals.

The demonstration software performs the initialization and configuration, processes data from the analog inputs, controls the analog output, and performs the HART communication.

Analog Output

The [AD5421](#) integrates a low power precision 16-bit DAC with a 4 mA to 20 mA, loop powered output driver and provides all functions required for the field instrument analog output.

The [AD5421](#) interfaces with the [ADuCM360](#) controller via the SPI interface.

The [AD5421](#) also includes a range of diagnostic functions related to the 4 mA to 20 mA loop. The auxiliary ADC can measure the voltage across the instruments loop terminals via the 20 M Ω /1 M Ω resistive divider connected to the V_{LOOP} pin. The ADC can also measure the chip temperature via the integrated sensor. The [ADuCM360](#) controller can configure and read all the diagnostics of the [AD5421](#), but the [AD5421](#) can also operate autonomously.

As an example, if the communication between the controller and the [AD5421](#) fails, the [AD5421](#) automatically sets its analog output to a 3.2 mA alarm current after a defined period. This alarm current indicates to the host that the field instrument failed to operate.

The software controls any change of the output current from one value to another to prevent disturbance of the HART communication. (See the Analog Rate of Change section).

HART Communication

The [AD5700](#) integrates a complete HART FSK modem. The modem is connected to the [ADuCM360](#) controller via a standard UART interface, complemented by request to send (RTS) and carrier detect (CD) signals.

The HART output is scaled to the required amplitude by the 0.068 μ F/0.22 μ F capacitive divider and coupled to the [AD5421](#) C_{IN} pin, where it is combined with the DAC output to drive and modulate the output current.

The HART input is coupled from LOOP+ via a simple passive RC filter to the [AD5700](#) ADC_IP pin. The RC filter works as the first stage, band-pass filter for the HART demodulator and also improves the system electromagnetic immunity, which is important for robust applications working in harsh industrial environments.

The [AD5700](#) low power oscillator generates the clock for the HART modem with a 3.8664 MHz external crystal connected directly to the XTAL1 and XTAL2 pins.

Output Protection

A transient voltage suppressor (TVS) protects the 4 mA to 20 mA HART interface from overvoltage. Its voltage rating should prevent exceeding the [AD5421](#) absolute maximum voltage of 60 V on the REG_{IN} pin. Note that the TVS leakage current can affect the current output accuracy; therefore, pay attention to the leakage current at a given loop voltage and temperature range when selecting this component.

An external depletion-mode FET can be used with the [AD5421](#) to increase the loop voltage maximum

The circuit is protected against reversed polarity by a pair of diodes in series with loop output.

The ferrite beads in series with the loop together with the 4700 pF capacitor improve the system EMC performance. Do not use a higher capacitance across the loop terminals because of the HART network specifications.

The 4.7 V, low leakage, Zener diode protects the [AD5421](#) on-chip, 50 Ω loop sense resistor in the event of an accidental external voltage between the [AD5421](#) COM pin and LOOP⁻ pin (for example, when programming the [ADuCM360](#) or debugging the circuit).

Power Supplies and Power Management

The complete field instrument circuitry, including the sensor drive current, must operate on the limited amount of power available from the 4 mA to 20 mA loop. This is a common challenge in any loop powered field instrument design. The circuit in Figure 1 provides an example of delivering both a low power and high performance solution. All three integrated circuits used in the application are designed for low power, and the circuit leverages their integrated features to deliver a flexible power management structure and an optimum loop-powered solution.

The [AD5421](#) is powered by the 4 mA to 20 mA loop voltage and provides a regulated low voltage for the rest of the circuit. The [AD5421](#) REG_{OUT} voltage is pin programmable from 1.8 V to 12 V depending on circuit requirements. The circuit in Figure 1 uses the 3.3 V supply voltage option as an example for the input sensors used. However, the [ADuCM360](#) and the [AD5700](#) have a wider power supply voltage range; therefore, a different power supply voltage can be used to suit the application.

The REG_{OUT} RC filter (10 μF/10 Ω/10 μF) helps to prevent any interference coming from the loop affecting the sensor analog front-end. It also prevents any interference generated by the circuit, specifically by the controller and the digital circuitry, from coupling back to the loop, which is important for a reliable HART communication.

The [AD5700](#) HART modem is supplied through an additional RC filter (470 Ω/1 μF). This filter is very important in the loop powered application because it prevents current noise from the [AD5700](#) from coupling to the 4 mA to 20 mA loop output, which would otherwise affect the HART communication. The 4 mA to 20 mA loop noise performance is specifically addressed by the HART in-band, noise during silence test. The [AD5700](#) modem uses the external crystal with 8.2 pF capacitors to ground on the XTAL1 and XTAL2 pins, which is the option using the least possible power.

The [ADuCM360](#) has very flexible internal power management, with many options for powering and clocking all the internal blocks and, when utilized by the software, allows an optimal balance between the required function, performance, and power for the specific instrument application. Refer to the [ADuCM360](#) product page and the [AN-1111 Application Note](#).

The analog front-end AVDD is supplied from another filter (10 μF/ferrite bead/1.6 Ω/10 μF) to minimize power supply noise for better performance with respect to low voltage sensor signals.

The GND_SW ground switch pin of the [ADuCM360](#) controls the excitation/power supply for the primary sensor. The switch is off as a default at the instrument power up. This default allows the system to be fully configured, including appropriate power modes, before turning on the sensor, and thus minimizes any possible power-up spikes on the 4 mA to 20 mA loop output.

Similarly, the secondary sensor is supplied from the programmable current source of the [ADuCM360](#), and therefore, its power is fully controlled by the software.

ADuCM360 Software

A basic code example that demonstrates the functionality and performance of the circuit can be found in the [CN-0267 Design Support Package](#).

The code example includes a basic HART slave command response to demonstrate the hardware function and capability. However, the code example does not include the protocol layers of the HART communication.

COMMON VARIATIONS

The [ADuCM360](#) has a high performance and very flexible analog front-end, with 12 analog input pins and extra pins for voltage reference and ground switch. It allows direct interface to multiple analog sensors of varying types, such as any resistive bridge sensors, resistive temperature sensors, or thermocouples. Therefore, do not limit the field instrument solution to temperature-compensated pressure measurement only because it can be used for almost any sensor field instrument.

The [ADuCM361](#) can be used as an alternative to the [ADuCM360](#) in applications that need only one Σ-Δ ADC in the analog front-end. Aside from the second ADC, the [ADuCM361](#) contains all the features of the [ADuCM360](#).

The [ADuCM361](#) on-chip DAC with an external transistor can be used to control the 4 mA to 20 mA loop, refer to [CN-0300](#) for details.

The [AD5421](#) can be connected via the protection directly to the loop. Alternatively, a depletion mode N-channel MOSFET can be connected between the [AD5421](#) and the loop power supply, as shown in Figure 2. The use of the additional MOSFET in this configuration keeps the voltage drop across the [AD5421](#) at approximately 12 V, lowers the power dissipated in the [AD5421](#) package, and therefore improves the 4 mA to 20 mA analog output accuracy. It also increases the maximum voltage allowed in the loop to the level of the MOSFET rating. The additional MOSFET has no effect on the HART communication.

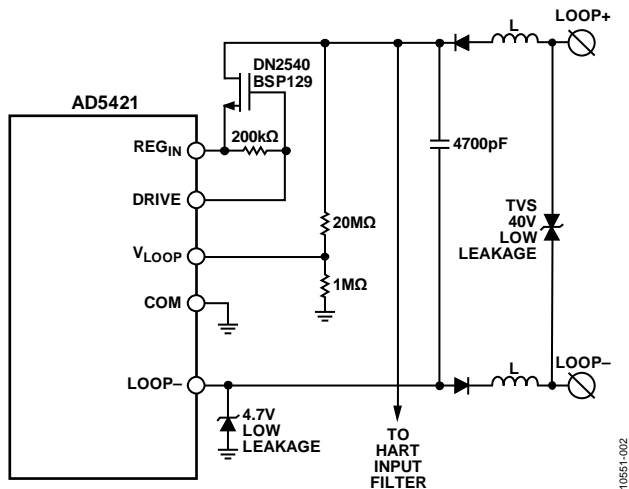

Figure 2. MOSFET Connected to the [AD5421](#) Loop Power Supply

The [AD5700](#) is used with a 3.8664 MHz crystal in this circuit, which is the configuration achieving the lowest power consumption. Alternatively, the [AD5700-1](#), with an integrated 0.5 % precision internal oscillator, can be used. The internal oscillator increases the modem power supply current by 225 μ A maximum, compared to the crystal oscillator, but because no external crystal is needed, this option provides both cost savings and reduced board area requirements.

For the applications that are not loop powered, the [AD5410](#), [AD5420](#), [AD5422](#), or [AD5755](#) are good choices for the 4 mA to 20 mA DAC.

CIRCUIT EVALUATION AND TEST

Circuit Hardware

The circuit shown in Figure 1 is built on the [DEMO-AD5700D2Z](#) printed circuit board shown in Figure 3.

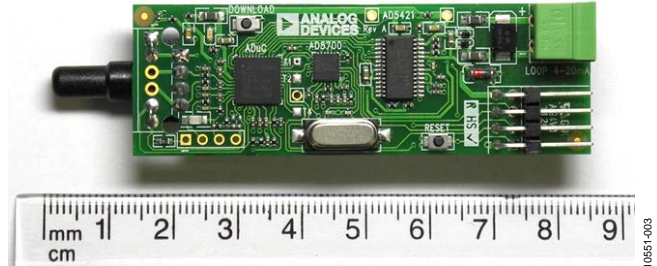

Figure 3. [DEMO-AD5700D2Z](#) Printed Circuit Board (Pressure Sensor Not Included)

The [DEMO-AD5700D2Z](#) circuit board includes some additional features for easy system evaluation. The 0.1 inch-pitch connector footprints allow optional primary and secondary sensor connections. There are test points for HART RTS and CD that may be needed for HART compliance tests.

A connector on the edge of the [DEMO-AD5700D2Z](#) makes the [ADuCM360](#) single wire and UART download/debug signals accessible allowing easy software development, code download, and in-circuit debugging and emulation. The connector, with a small header extender included with the [DEMO-AD5700D2Z](#) board, is compatible with all Analog Devices, Inc., Cortex-M3 based development tools, such as the [EVAL-ADuCM360QSPZ](#) evaluation kit (the evaluation kit is not included with the [DEMO-AD5700D2Z](#) board).

These features are not shown in the simplified diagram in Figure 1; however, they can be seen in the complete circuit schematic in the [CN-0267 Design Support Package](#). The design support package also includes a full field instrument C-code example, which enables complete verification and evaluation of all hardware blocks and features of the circuit, and a limited verification of the HART interface functionality. For detailed information about HART interface specifications and resources, contact the Hart Communication Foundation.

HART Compliance

The [DEMO-AD5700D2Z](#) has been verified to be compliant with HART FSK Physical Layer Specification (HCF_SPEC-054, Revision 8.1), using methods and equipment specified in the HART Physical Layer Test Specification (HCF_TEST-2, Revision 2.2). The board was submitted to the Hart Communication Foundation and was successfully registered.

The registered circuit can be found on the Hart Communication Foundation (HCF) web site in the product catalog as [DEMO-AD5700D2Z](#).

The results of two of the tests involved the output noise during silence and the analog rate of change.

Output Noise During Silence Test

When a HART device is not transmitting (silence), do not couple noise onto the network. Excessive noise may interfere with reception of HART signals by the device itself or other devices on the network.

The voltage noise measured across a 500 Ω load in the loop must contain no more than 2.2 mV rms of combined broadband and correlated noise in the HART extended frequency band. In addition, the noise should not exceed 138 mV rms outside the HART extended frequency band.

This noise was measured by a true rms meter across the 500 Ω load. This noise was measured directly for the out-of-band noise and measured through the HCF_TOOL-31 filter for the in-band noise. An oscilloscope was also used to examine the noise waveform.

The noise was measured at the worse condition, which was 4 mA output current. The captured noise waveform is shown in Figure 4, and the results are summarized in Table 1.

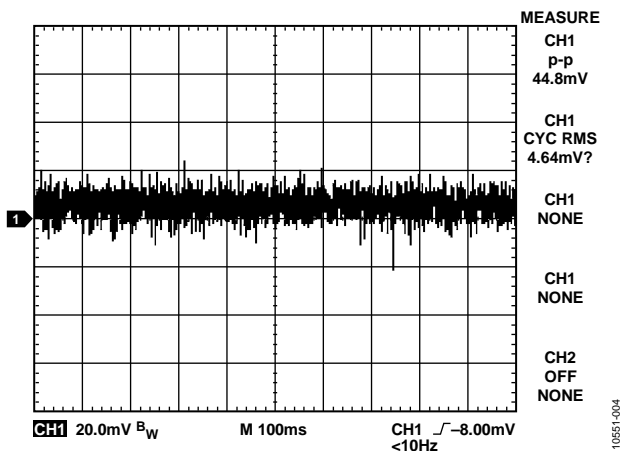

Figure 4. Output Noise During Silence Waveform

Table 1. Output Noise During Silence

| Output Noise | Measured (mV) | Required (mV) |
|----------------------------------|---------------|---------------|
| Outside Extended Frequency Range | 4.13 | <138 |
| Inside Extended Frequency Range | 1.03 | <2.2 |

Analog Rate of Change Test

This specification ensures that when a device regulates the analog output current, the maximum rate of change of analog current does not interfere with HART communications. Step changes in current disrupt HART signaling.

The worst-case change in the analog output current must not produce a disturbance higher than 15 mV peak, measured across a 500 Ω load in the HART extended frequency band.

The AD5421 DAC and output driver are relatively fast. Therefore, to meet the required system specification, the output current change is controlled by combining hardware slew-rate limiting implemented at the AD5421 and a digital filter implemented in the ADuCM360 software.

The hardware slew-rate limit is set by the capacitance connected to the AD5421 C_{IN} pin. When a large step change is required in the analog output current value, the ADuCM360 software splits the output current change sent to the AD5421 DAC into a number of smaller subsequent steps.

This test was performed using an oscilloscope coupled to the 500 Ω load through the HCF_TOOL-31 filter.

The result is shown in Figure 5. Waveform CH1 shows the periodic steps between 4 mA and 20 mA, sensed directly across the 500 Ω load. Waveform CH2 is the signal captured on the HCF_TOOL-31 filter output, amplified 10×, within the 150 mV peak limits.

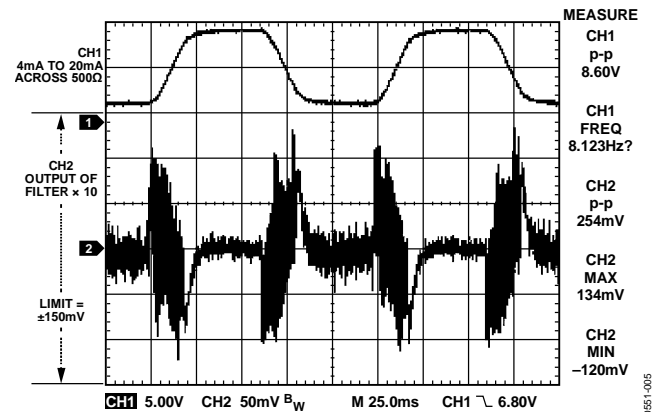

Figure 5. Analog Rate of Change Waveform

Circuit Power Consumption

Two methods were used to evaluate the circuit power consumption performance.

In the first method, the current from the AD5421 integrated voltage regulator output was measured.

Considering the minimum analog output current of 4 mA and HART output ac modulation of 0.5 mA peak, the maximum current consumed by the circuit in normal mode operation must be less than 3.5 mA. The AD5421 requires a 0.3 mA maximum for its own operation, which leaves approximately 3.2 mA maximum current for the AD5421 REG_{OUT} output.

For ease of in-circuit measurement, the DEMO-AD5700D2Z has test points (T5, T6) on each side of the 10 Ω resistor in the REG_{OUT} output filter, as shown in Figure 6. This setup allows the voltage drop across the resistor to be measured, and the current to be calculated without interrupting the supply current or disturbing the circuit.

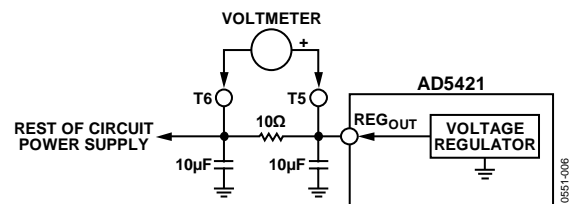

Figure 6. Measuring the AD5421 REG_{OUT} Current Using Test Points

The results are shown in Table 2 and were measured at the following conditions:

- $REG_{OUT} = 3.3\text{ V}$
- ADuCM360 M3 core clock = 2 MHz
- Both ADCs converting at 50 samples per second
- ADC0 has both buffers on and gain = 8
- ADC1 has both buffers on and gain = 16
- RTD excitation current = 200 μA
- SPI communicating to AD5421 with serial clock = 100 kHz
- HART communicating

The circuit with all relevant analog and digital blocks, including the input sensor, consumes power supply current within the budget allowed at the minimum 4 mA loop current.

Table 2. Power Supply Current from AD5421, $REG_{OUT} = 3.3\text{V}$

| Input Sensor | Voltage T5 to T6 Maximum (mV) | Current REG_{OUT} Maximum (mA) |
|---|-------------------------------|----------------------------------|
| None | 24.4 | 2.44 |
| 24PCDFA6D (5 k Ω , 0.66 mA at 3.3 V) | 31.0 | 3.10 |

In the second method for assessing the circuit power consumption, the circuit was verified to function as expected with the analog output current set to the minimum of 4 mA while performing HART communication. The result showed that the circuit delivered the 4 mA current and showed no distortion of the HART output signal.

Primary Sensor Input Performance

The ADuCM360 integrates most of the analog front-end on chip; therefore, the performance of the analog input is primarily determined by the specifications of the ADuCM360.

The level of noise is the main factor that can be influenced by the interaction of the analog front-end with the rest of the circuitry on the board. Thus, tests were carried out to focus on the noise and related resolution performance of the system.

The demonstration was configured to transmit data from the primary analog input, expressed as pressure in kPa, over the HART communication. One hundred samples were captured, and a basic data analysis to quantify the performance was completed. Two of the tests involved the following:

- The first test was performed with a standard pressure sensor (Honeywell 24PCDFA6D) soldered directly on the board.
- A second test was performed with the primary input signal generated by a set of fixed and variable resistors, as shown in Figure 7.

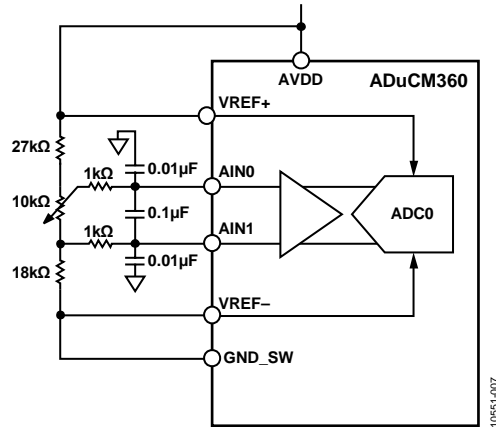

Figure 7. Primary Input Signal Generated by a Set of Resistors

The performance summary can be seen in Table 3, and the signal plots are shown in Figure 8 and Figure 9.

Table 3. Primary Sensor Input Noise and Resolution

| Parameter | Pressure Sensor | Resistive Network |
|-----------------------------|-----------------|-------------------|
| Full Scale | 207 kPa | 246 kPa |
| Noise RMS | 1.3 Pa | 0.68 Pa |
| Peak-to-Peak Noise | 6.8 Pa | 3.6 Pa |
| Resolution Effective (rms) | 17.2 bit | 18.5 bit |
| Noise-Free Resolution (p-p) | 14.9 bit | 16.1 bit |

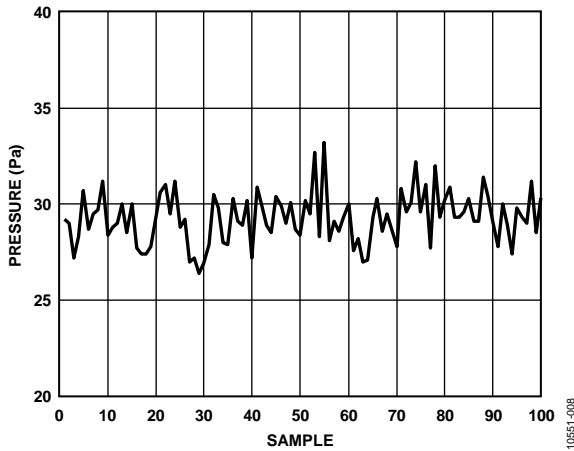

Figure 8. Pressure Sensor Input Signal Plot

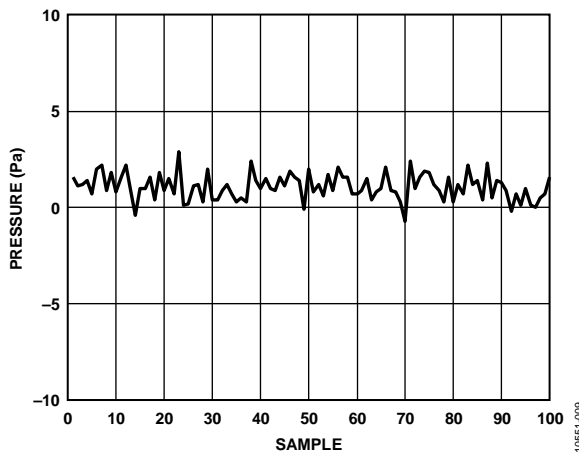

Figure 9. Resistive Network as Primary Input Signal Plot

Secondary Sensor Input Performance

Similar to the primary sensor, the performance of the secondary sensor input is mainly determined by the analog front-end of the ADuCM360 with the exception of noise performance.

The analog input was configured to transmit temperature in degrees Celsius (°C) to a master over the HART communication path. Analysis was performed on two tests of 100 samples to quantify the performance.

The first test was performed using the platinum 100 Ω sensor on the board, and the second test was performed with the sensor replaced on the board by a standard (fixed) 100 Ω ± 1% resistor.

The performance summary is shown in Table 4, and the signal plots are shown in Figure 10 and Figure 11.

Table 4. Secondary Sensor Input Noise Performance

| Parameter | Pressure Sensor | Resistive Network |
|--------------------|-----------------|-------------------|
| Noise RMS | 0.037°C | 0.033°C |
| Noise Peak to Peak | 0.19°C | 0.16°C |

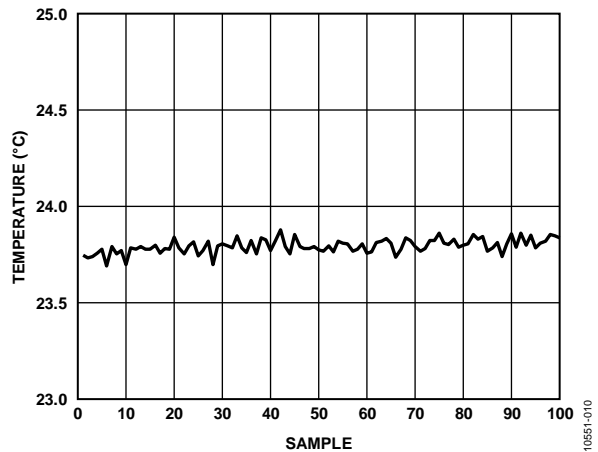

Figure 10. RTD (Platinum 100 Ω) Sensor Input Signal Plot

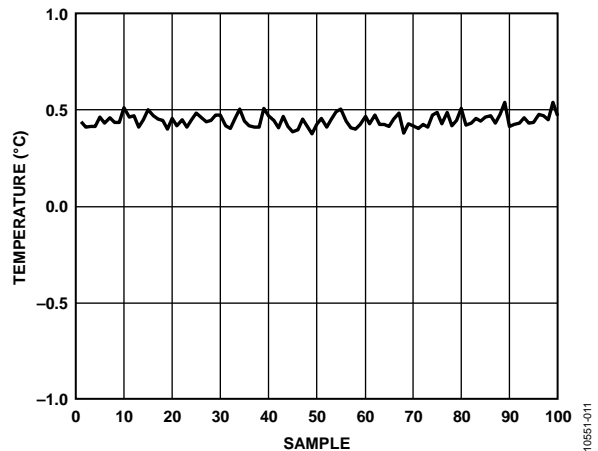

Figure 11. Fixed 100 Ω ± 1% Resistor as the Secondary Input Signal Plot

LEARN MORE

CN-0267 Design Support Package:

<http://www.analog.com/CN0267-DesignSupport>

CN-0270, *Complete 4 mA to 20 mA HART Solution*

CN-0278, *Complete 4 mA to 20 mA HART Solution with Additional Voltage Output Capability*

CN-0300, *Complete Closed-Loop Precision Analog Microcontroller Thermocouple Measurement System with 4 mA to 20 mA Output*

AN-1111, *Options for Minimizing Power Consumption When Using the ADuCM360/ADuCM361*

HART® Communication Foundation

Data Sheets and Evaluation Boards

[ADuCM360 Data Sheet and Evaluation Board](#)

[AD5421 Data Sheet and Evaluation Boards](#)

[AD5700 Data Sheet and Evaluation Board](#)

REVISION HISTORY

2/13—Rev. 0 to Rev. A

Changes to Circuit Hardware Section and Figure 3 Caption4

12/12—Revision 0: Initial Version

(Continued from first page) Circuits from the Lab circuits are intended only for use with Analog Devices products and are the intellectual property of Analog Devices or its licensors. While you may use the Circuits from the Lab circuits in the design of your product, no other license is granted by implication or otherwise under any patents or other intellectual property by application or use of the Circuits from the Lab circuits. Information furnished by Analog Devices is believed to be accurate and reliable. However, Circuits from the Lab circuits are supplied "as is" and without warranties of any kind, express, implied, or statutory including, but not limited to, any implied warranty of merchantability, noninfringement or fitness for a particular purpose and no responsibility is assumed by Analog Devices for their use, nor for any infringements of patents or other rights of third parties that may result from their use. Analog Devices reserves the right to change any Circuits from the Lab circuits at any time without notice but is under no obligation to do so.

©2012–2013 Analog Devices, Inc. All rights reserved. Trademarks and registered trademarks are the property of their respective owners.
CN10551-0-2/13(A)

