

2SK3902

Features

- Low On-state resistance
 $R_{DS(on)1} = 21\text{m}\Omega \text{ MAX. (}V_{GS} = 10\text{ V, }I_D = 15\text{ A)}$
 $R_{DS(on)2} = 26\text{ m}\Omega \text{ MAX. (}V_{GS} = 4.5\text{ V, }I_D = 15\text{ A)}$
- Low C_{iss} : $C_{iss} = 1200\text{ pF TYP.}$

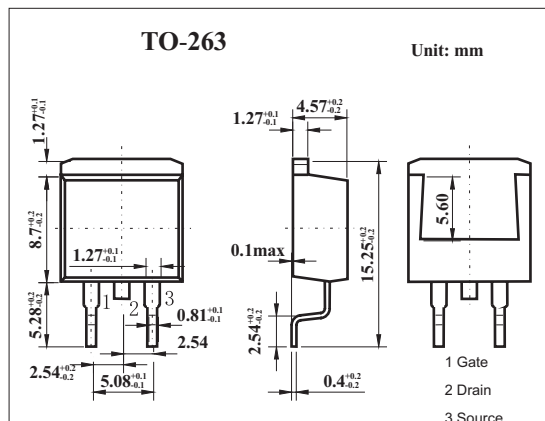

Absolute Maximum Ratings $T_a = 25^\circ\text{C}$

Parameter	Symbol	Rating	Unit
Drain to source voltage	V_{DSS}	60	V
Gate to source voltage	V_{GSS}	± 20	V
Drain current	I_D	± 30	A
	I_{dp}^*	± 90	A
Power dissipation	PD	$T_a=25^\circ\text{C}$	1.5
		$T_c=25^\circ\text{C}$	45
Channel temperature	T_{ch}	150	$^\circ\text{C}$
Storage temperature	T_{stg}	-55 to +150	$^\circ\text{C}$

* $PW \leq 10\ \mu\text{s}$, Duty Cycle $\leq 1\%$

Electrical Characteristics $T_a = 25^\circ\text{C}$

Parameter	Symbol	Testconditions	Min	Typ	Max	Unit
Drain cut-off current	I_{DSS}	$V_{DS}=60\text{V, }V_{GS}=0$			10	$\mu\text{ A}$
Gate leakage current	I_{GSS}	$V_{GS}=\pm 20\text{V, }V_{DS}=0$			± 10	$\mu\text{ A}$
Gate cut off voltage	$V_{GS(off)}$	$V_{DS}=10\text{V, }I_D=1\text{mA}$	1.5	2.0	2.5	V
Forward transfer admittance	$ Y_{fs} $	$V_{DS}=10\text{V, }I_D=15\text{A}$	9.5	19		S
Drain to source on-state resistance	$R_{DS(on)1}$	$V_{GS}=10\text{V, }I_D=15\text{A}$		16.8	21	$\text{m}\Omega$
	$R_{DS(on)2}$	$V_{GS}=4.5\text{V, }I_D=15\text{A}$		19.5	26	$\text{m}\Omega$
Input capacitance	C_{iss}	$V_{DS}=10\text{V, }V_{GS}=0, f=1\text{MHZ}$		1200		pF
Output capacitance	C_{oss}			250		pF
Reverse transfer capacitance	C_{rss}			85		pF
Turn-on delay time	t_{on}			10		ns
Rise time	t_r	$I_D=15\text{A, }V_{GS(on)}=10\text{V, }R_G=0\ \Omega, V_{DD}=30\text{V}$		4		ns
Turn-off delay time	t_{off}			37		ns
Fall time	t_f			4		ns
Total Gate Charge	Q_G		$V_{DD} = 48\text{V}$		25	
Gate to Source Charge	Q_{GS}	$V_{GS} = 10\text{ V}$		4.5		nC
Gate to Drain Charge	Q_{GD}	$I_D = 30\text{A}$		6.0		nC