

PANDUIT PART NUMBER	WIRE SIZE AWG (mm ²)	DIMENSIONS in.				
		±.020 A (±,5)	±.010(±,3) B DIA.	±.015 C (±,4)	±.010(±,3) D DIA.	±.010(±,3) E DIA.
P18-P47	22-18 (1,5-1,5)	.75 (19,1)	.07 (1,8)	.49 (12,4)	.14 (3,6)	.06 (1,5)
P14-P47	16-14 (2,0-2,5)	.75 (19,1)	.07 (1,8)	.49 (12,4)	.16 (4,1)	.08 (2,0)
P10-P55	12-10 (4,0-6,0)	.79 (20,1)	.11 (2,8)	.55 (14,0)	.22 (5,6)	.15 (3,8)

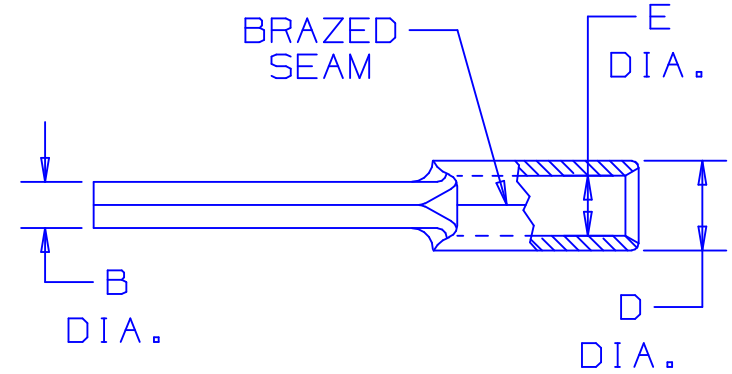

NOTES:

- RECOMMENDED FOR:
A. SOLID OR STRANDED COPPER WIRE
- MATERIAL:
A. STAMPING - COPPER, TIN PLATED
- PACKAGE QTY: STD. PKG. -C=100
BULK PKG. -M=1000
- DIMENSIONS IN BRACKETS ARE IN mm or mm²
- INSTALLATION TOOLS:
A. PANDUIT APPROVED: CT-100, CT-160, CT-200, CT-260, CT-1570,
- WIRE STRIP LENGTH: 9/32 ^{+1/32}₋₀ (7,1 ^{+0,8}₋₀)

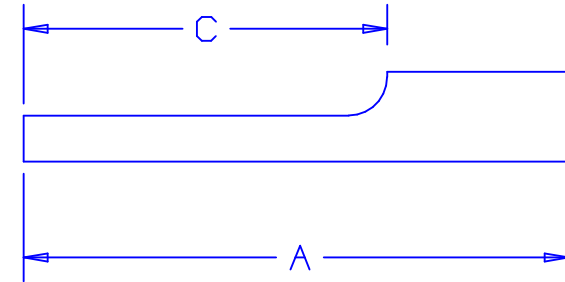

A41334_04

4	1/01	EJS		REMOVED CT-570 FROM TOOL LIST, "A" TOL. WAS ,8			
3	2/99	WB	SKB	UPDATED NOTES & DIMENSIONS	07530	JCJ	TRO
2	3-95	MS	RS	UPDATED NOTES AND DIMENSIONS	03123	LA	KS
1	9-88	DW		REDRAWN WITH REVISIONS			
REV	DATE	BY	CHK	DESCRIPTION	ECN #	CUST	PM

PANDUIT CORP.

TINLEY PARK, ILLINOIS

NON-INSULATED PIN TERMINAL

DRAWN BY DAW	CHK'D RLS	SCALE NONE	DRAWING NO. A41334
-----------------	--------------	---------------	-----------------------