

EC3SM1 Series

- Four pad surface mount package
- AT or BT cut available
- Resistance weld seal
- Tight tolerance/stability
- Interchangeable with plastic surface mount crystals
- Tape and reel available

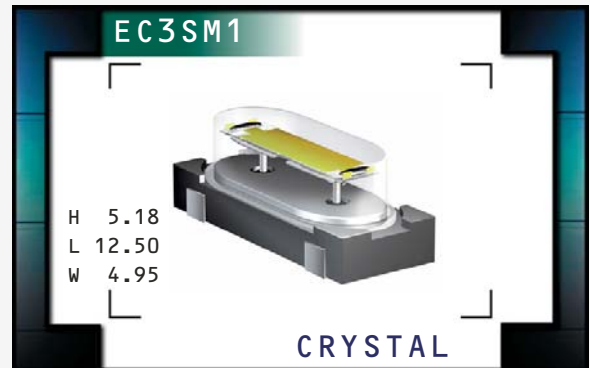

NOTES

ELECTRICAL SPECIFICATIONS

Frequency Range	3.579545MHz to 40.000MHz
Frequency Tolerance / Stability	±50ppm / ±100ppm (Standard), ±30ppm / ±50ppm (AT cut only), ±15ppm / ±30ppm (AT cut only),
Over Operating Temperature Range	±15ppm / ±20ppm (AT cut only), or ±10ppm / ±15ppm (AT cut only)
Operating Temperature Range	0°C to 70°C (Standard), -20°C to 70°C (AT cut only), or -40°C to 85°C (AT cut only)
Aging (at 25°C)	±5ppm / year Maximum
Storage Temperature Range	-40°C to 85°C
Shunt Capacitance	7pF Maximum
Insulation Resistance	500 Megaohms Minimum at 100V _{DC}
Drive Level	1 mWatt Maximum
Load Capacitance (C_L)	18pF (Standard), Custom C _L ≥10pF, or Series Resonant

EQUIVALENT SERIES RESISTANCE (ESR), MODE OF OPERATION (MODE), AND CUT

Frequency Range	ESR (Ω)	Mode / Cut	Frequency Range	ESR (Ω)	Mode / Cut
3.579545MHz to 4.999MHz	200 Max	Fundamental / AT	15.000MHz to 15.999MHz	60 Max	Fundamental / AT
5.000MHz to 5.999MHz	150 Max	Fundamental / AT	16.000MHz to 23.999MHz	50 Max	Fundamental / AT
6.000MHz to 7.999MHz	120 Max	Fundamental / AT	24.000MHz to 30.000MHz	40 Max	Fundamental / AT
8.000MHz to 8.999MHz	90 Max	Fundamental / AT	24.000MHz to 40.000MHz	40 Max	Fundamental / BT
9.000MHz to 9.999MHz	80 Max	Fundamental / AT			
10.000MHz to 14.999MHz	70 Max	Fundamental / AT			

PART NUMBERING GUIDE

EC3SM1 - B - 20 - 40.000M TR

FREQUENCY TOLERANCE / STABILITY

Blank=±50ppm at 25°C, ±100ppm from 0°C to 70°C
 A=±50ppm at 25°C, ±100ppm from -20°C to 70°C
 B=±50ppm at 25°C, ±100ppm from -40°C to 85°C
 C=±30ppm at 25°C, ±50ppm from 0°C to 70°C
 D=±30ppm at 25°C, ±50ppm from -20°C to 70°C
 E=±30ppm at 25°C, ±50ppm from -40°C to 85°C
 F=±15ppm at 25°C, ±30ppm from 0°C to 70°C
 G=±15ppm at 25°C, ±30ppm from -20°C to 70°C
 H=±15ppm at 25°C, ±30ppm from -40°C to 85°C
 J=±15ppm at 25°C, ±20ppm from 0°C to 70°C
 K=±15ppm at 25°C, ±20ppm from -20°C to 70°C
 L=±15ppm at 25°C, ±20ppm from -40°C to 85°C
 M=±10ppm at 25°C, ±15ppm from 0°C to 70°C
 N=±10ppm at 25°C, ±15ppm from -20°C to 70°C

PACKAGING OPTIONS

Blank=Bulk, TR=Tape and Reel

FREQUENCY

LOAD CAPACITANCE

Blank=18pF (Standard), S=Series
 XX=XXpF (Custom)

MODE OF OPERATION / CRYSTAL CUT

Blank=Fundamental / AT
 B=Fundamental / BT

MECHANICAL DIMENSIONS

ALL DIMENSIONS IN MILLIMETERS

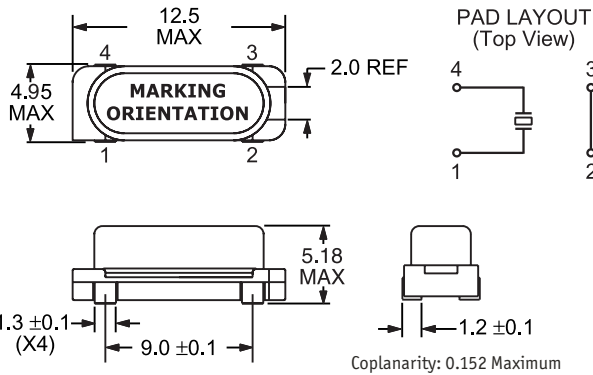

SUGGESTED SOLDER PAD LAYOUT

ALL DIMENSIONS IN MILLIMETERS

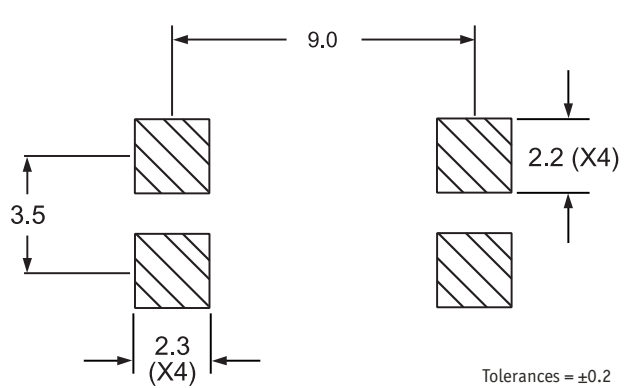

TAPE AND REEL DIMENSIONS

ALL DIMENSIONS IN MILLIMETERS

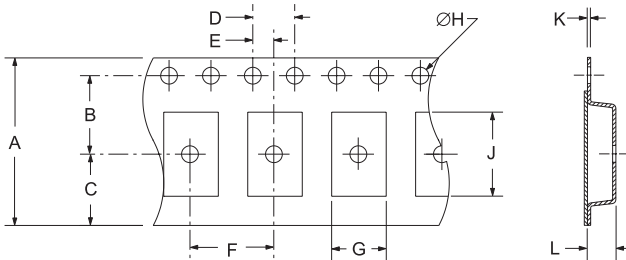

TAPE	A	B	C	D	E
	24±.3	11.5±.1	10.75±.1	4±.1	2±.1
F	G	H	J	K	L
	12±.1	5.4±.1	1.5+.1	12.5±.1	.4±.05
					5.35±0.2

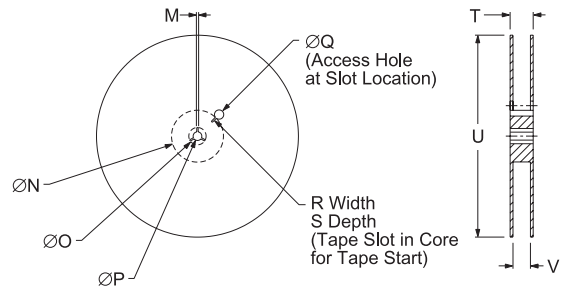

REEL	M	N	O	P	Q
	1.5 MIN	50 MIN	20.2 MIN	13±.2	40 MIN
R	S	T	U	V	QTY/REEL
	2.5 MIN	10 MIN	30.4 MAX	360 MAX	24.4+2-0
					1,000

*Compliant to EIA-481A

ENVIRONMENTAL/MECHANICAL SPECIFICATIONS

PARAMETER	SPECIFICATION
Fine Leak Test	MIL-STD-883, Method 1014, Condition A
Gross Leak Test	MIL-STD-883, Method 1014, Condition C
Mechanical Shock	MIL-STD-202, Method 213, Condition C
Vibration	MIL-STD-883, Method 2007, Condition A
Solderability	MIL-STD-883, Method 2002
Temperature Cycling	MIL-STD-883, Method 1010
Resistance to Soldering Heat	MIL-STD-883, Method 210
Resistance to Solvents	MIL-STD-883, Method 215

MARKING SPECIFICATIONS

Line 1: E XX.XXX
 Frequency in MHz
 (5 Digits Maximum + Decimal)

MANUFACTURER
 ECLIPTEK CORP.

CATEGORY
 CRYSTAL

SERIES
 EC3SM1

PACKAGE
 EPOXY BASE

CLASS
 CR34

REV. DATE
 09/05