

ULTRA MINIATURE CERAMIC SMD CRYSTAL



3.2 x 2.5 x 0.8mm

ABM8

FEATURES:

- Low in height; suitable for thin equipment.
- Ceramic package and metal lid assures high reliability.
- Tight tolerance and stability available.
- Suitable for solder reflow.
- High precision crystal, fundamental mode.

APPLICATIONS:

- High density applications.
- Modems, communication and test equipment.
- PCMCIA, Wireless applications.

STANDARD SPECIFICATIONS:

PARAMETERS	
Frequency Range	10.00 MHz - 60.00 MHz
Operation Mode	Fundamental
Operating Temperature	-10°C to + 60°C (see options)
Storage Temperature	- 55°C to + 125°C
Frequency Tolerance @ 25°C	± 50 ppm max. (see options)
Frequency Stability over Temp.	± 50 ppm max. (see options)
Equivalent Series Resistance	See Table 1
Shunt Capacitance C ₀	7pF max.
Load Capacitance C _L	18pF (see options)
Drive Level	100μΩ max., 10μΩ correlation
Aging at 25°C First Year	± 5ppm max.
Insulation Resistance	500MΩ min. @ 100Vdc ± 15V

MARKING:

- XX.X (Frequency in MHz)
- A ZYX (ZY: date code, e.g. L2;
Z: month A to L;
Y: last digit of year;
X: Traceability code)

TABLE 1

FREQ (MHz)	ESR (Ω)max.
10.000 - 15.999	200
16.000 - 19.999	100
20.000 - 29.999	80
30.000 - 60.000	50

TABLE 2

Height (mm)	Chamfer PIN #
ABM8	0.70+/-0.10 #1
ABM81	0.65+/-0.05 #1
ABM82	0.60+/-0.10 #4
ABM83	0.55+/-0.05 #1

OUTLINE DRAWING:

Please see Table 2 below for height and chamfer information.

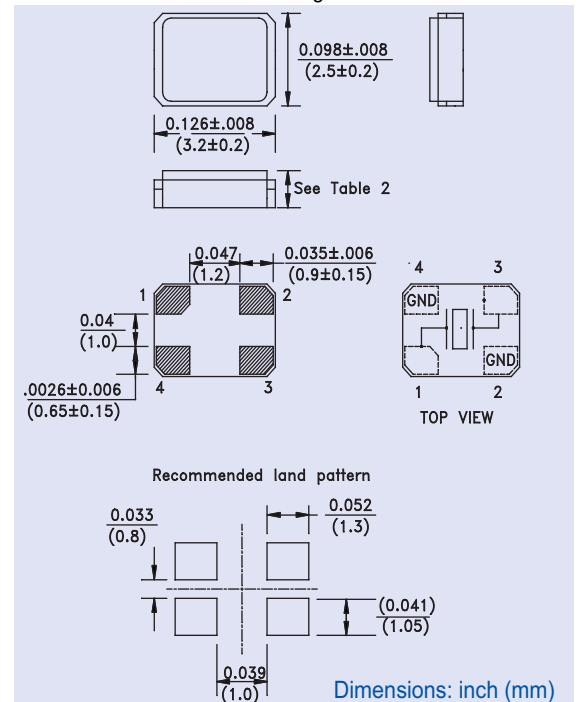

ULTRA MINIATURE CERAMIC SMD CRYSTAL



3.2 x 2.5 x 0.8mm

ABM8

➤ OPTIONS AND PART IDENTIFICATION (Left blank if standard):

ABM8□ - Frequency - □ - R□□□ - □ - □ - □ - □

Height (mm)	
Blank	0.70+/-0.10
1	0.65+/-0.05
2	0.60+/-0.10
3	0.55+/-0.05

Load Capacitance
Please specify CL in pF or S for Series (minimum 10pF)

ESR
RXXX (value in ohms if it is custom.)

Operating Temp.	
E	0°C to +70°C
B	-20°C to +70°C
C	-30°C to +70°C
N	-30°C to +85°C
D	-40°C to +85°C

Freq. Tolerance	
1	± 10 ppm
7	± 15 ppm
2	± 20 ppm
3	± 25 ppm
4	± 30 ppm

Freq. Stability	
U	± 10 ppm (*)
G	± 15 ppm (*)
X	± 20 ppm (*)
W	± 25 ppm (*)
Y	± 30 ppm (*)
H	± 35 ppm
Z	± 100 ppm (#)

*Contact ABRACON for wider temp range.

Packaging	
T	Tape and Reel

(*) -10°C to +60°C only

(#) For extended temperatures

*Contact ABRACON for tighter freq. stability.

Tape and reel (1,000pcs/reel) : ABM8, ABM81, ABM82

Tape and reel (3,000pcs/reel) : ABM83

➤ MARKING:

Marking 1 for ABM8, ABM81, ABM82

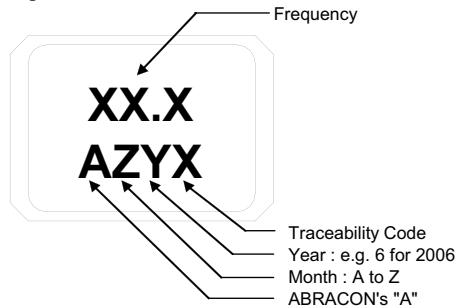

Month	Code
January	A
February	B
March	C
April	D
May	E
June	F
July	G
August	H
September	I
October	J
November	K
December	L

Marking 2 for ABM83

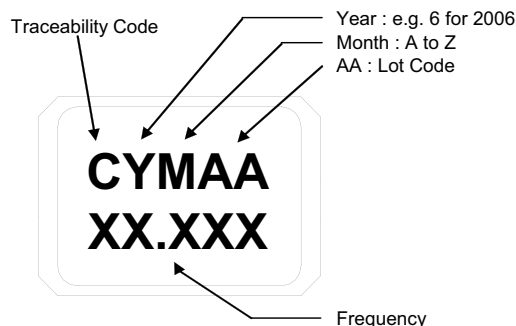

Month	Code
January	1
February	2
March	3
April	4
May	5
June	6
July	7
August	8
September	9
October	X
November	Y
December	Z