

- 100% Tested at Probe ①
- Available in Tape and Reel (upon request), Chip Pack, and Sawn on Film ②

600V  
V<sub>F</sub> = 2.2 V  
(max.)  
5" Wafer

**Electrical Characteristics @ T<sub>J</sub> = 25°C (unless otherwise specified)**

Parameter	Description	Min	Typ	Max	Test Conditions
V <sub>FM</sub>	Maximum Forward Voltage	—	—	2.2V	T <sub>J</sub> = 25°C, I <sub>F</sub> = 15A
V <sub>RRM</sub>	Minimum Reverse Breakdown Voltage	600V	—	—	T <sub>J</sub> = 25°C, I <sub>RRM</sub> = 200μA
I <sub>RM</sub>	Max. Reverse Leakage Current	—	—	50μA	T <sub>J</sub> = 25°C, V <sub>RRM</sub> = 600V
t <sub>rr</sub>	Typ. Reverse Recovery Time	—	22ns	—	I <sub>F</sub> = 1A, di/dt = 100A/μs, V <sub>R</sub> = 30V
		—	28ns	—	I <sub>F</sub> = 15A, di/dt = 100A/μs, V <sub>R</sub> = 30V
Q <sub>rr</sub>	Typ. Reverse Recovery Charge	—	580nC	—	T <sub>J</sub> = 125°C, I <sub>F</sub> = 15A, di/dt = 800A/μs, V <sub>R</sub> = 390V

**Mechanical Data**

Nominal Back Metal Composition, Thickness:	Cr-Ni-Ag ( 1kA-2kA-3kA)
Nominal Front Metal Composition, Thickness:	99%Al, 1%Si (3μm)
Dimensions:	0.120" x 0.120" (see drawing)
Wafer Diameter:	125 mm
Wafer Thickness:	14 mils
Scribe Line Width	90 ±10 μm
Reject Ink Dot Size	0.25 mm Diameter Minimum
Recommended Storage Environment:	Store in original container, in dessicated nitrogen, with no contamination
Recommended Die Attach Conditions:	For optimum electrical results, die attach temperature should not exceed 300 °C
Reference Packaged Part	15ETH06 Series

**Die Outline**

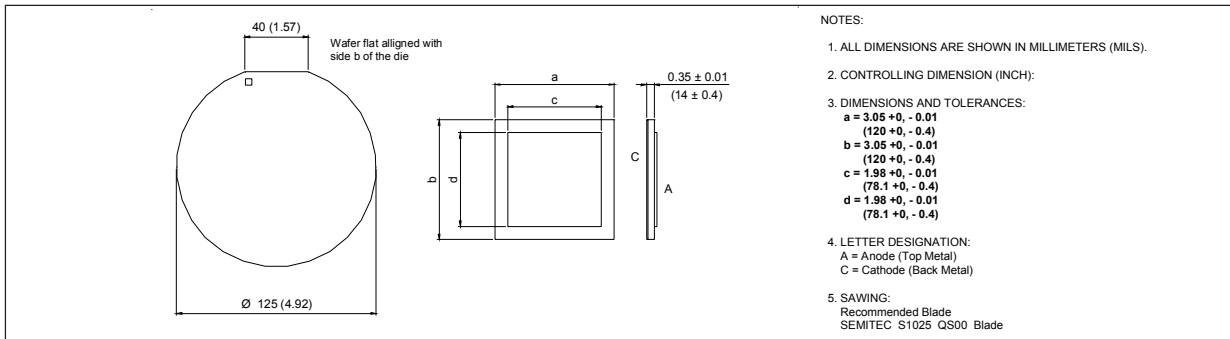

Note:

① The above data sheet is based on IR sample testing under certain predetermined and assumed conditions, and is provided for illustration purposes only. Customers are encouraged to perform testing in actual proposed packaged and use conditions. IR die products are tested using IR-based quality assurance procedures and are manufactured using IR's established processes. Programs for customer-specified testing are available upon request. IR has experienced assembly yields of generally 95% or greater for individual die; however, customer's results may vary. Estimates such as those described and set forth in this data sheet for semiconductor die will vary depending on a number of packaging, handling, use and other factors. Sold die may not perform on an equivalent basis to standard package products and are therefore offered with a limited warranty as described in IR's applicable standard terms and conditions of sale. All IR die sales are subject to IR's applicable standard terms and conditions of sale, which are available upon request.

② Part number shown is for die in waveform. Contact factory for these other options.

09/08/06

# FD120H06A5B

## Additional Testing and Screening

For Customers requiring product supplied as Known Good Die (KGD) or requiring specific die level testing, please contact your local IR Sales.

## Shipping

Three shipping options are offered as standard.

- Un-sawn wafer
- Die in waffle pack
- Die on film

Tape and Reel is also available for some products. Please consult your local IR sales office or email [DieSales@irf.com](mailto:DieSales@irf.com) for additional information.

Please specify your required shipping option when requesting prices and ordering Die product. If not specified, Un-sawn wafer will be assumed.

## Packaging

Device	Description	Minimum Order Quantity Die in sale Package
FD120H06A5B	Inked Probed Unsawn Wafer (Wafer in Box)	900
FD120H06A5R	Probed Die in Tape & Reel	n/a contact Factory
FD120H06A5P	Probed Die in Waffle Pack	900
FD120H06A5F	Inked Probed Sawn Wafer on Film	900

## Handling

- Product must be handled only at ESD safe workstations. Standard ESD precautions and safe work environments are as defined in MIL-HDBK-263.
- Product must be handled only in a class 10,000 or better-designated clean room environment.
- Singulated die are not to be handled with tweezers. A vacuum wand with a non-metallic ESD protected tip should be used.

## Wafer/Die Storage

- Proper storage conditions are necessary to prevent product contamination and/or degradation after shipment.
- Un-sawn wafers and singulated die can be stored for up to 12 months when in the original sealed packaging at room temperature (45% +/- 15% RH controlled environment).
- Un-sawn wafers and singulated die that have been opened can be stored when returned to their containers and placed in a Nitrogen purged cabinet, at room temperature (45% +/- 15% RH controlled environment).
- Note: To reduce the risk of contamination or degradation, it is recommended that product not being used in the assembly process be returned to their original containers and resealed with a vacuum seal process.
- Sawn wafers on a film frame are intended for immediate use and have a limited shelf life.
- Die in Surf Tape type carrier tape are intended for immediate use and have a limited shelf life. This is primarily due to the nature of the adhesive tape used to hold the product in the carrier tape cavity. This product can be stored for up to 30 days. This applies whether or not the material has remained in its original sealed container.

## Further Information

For further information please contact your local IR Sales office or email your enquiry to [DieSales@irf.com](mailto:DieSales@irf.com)



## Notice

The products described herein were acquired by Vishay Intertechnology, Inc., as part of its acquisition of International Rectifier's Power Control Systems (PCS) business, which closed in April 2007. Specifications of the products displayed herein are pending review by Vishay and are subject to the terms and conditions shown below.

Specifications of the products displayed herein are subject to change without notice. Vishay Intertechnology, Inc., or anyone on its behalf, assumes no responsibility or liability for any errors or inaccuracies.

Information contained herein is intended to provide a product description only. No license, express or implied, by estoppel or otherwise, to any intellectual property rights is granted by this document. Except as provided in Vishay's terms and conditions of sale for such products, Vishay assumes no liability whatsoever, and disclaims any express or implied warranty, relating to sale and/or use of Vishay products including liability or warranties relating to fitness for a particular purpose, merchantability, or infringement of any patent, copyright, or other intellectual property right.

The products shown herein are not designed for use in medical, life-saving, or life-sustaining applications. Customers using or selling these products for use in such applications do so at their own risk and agree to fully indemnify Vishay for any damages resulting from such improper use or sale.

International Rectifier®, IR®, the IR logo, HEXFET®, HEXSense®, HEXDIP®, DOL®, INTERO®, and POWIRTRAIN® are registered trademarks of International Rectifier Corporation in the U.S. and other countries. All other product names noted herein may be trademarks of their respective owners.