



DESCRIPTION

PT2353 is a 3-speaker system electronic crossover IC utilizing CMOS Technology specially designed for the new generation of audio equipments. 3-channel electronic volume control, 2-channel 2nd order high pass filter, 2nd order low pass filter and one mono subwoofer audio output are incorporated into a single high performance chips. PT2353 combines the electronic volume controller and crossover circuitry without MCU handling. Pin assignments and application circuit are optimized for easy PCB layout and cost saving advantages.

FEATURES

- CMOS technology
- Low power consumption
- 2 built-in individual volume control: 0dB to -60dB
- 2-channel 2nd order high pass filter + 1 mixed mono subwoofer low pass filter
- Cross-over frequency adjustable by external passive components
- Control interface of volume control: Up/Down key (MCU is not necessary)
- Built-in 3D effect and loudness function
- Supply voltage: 5V to 9V

APPLICATION

- Audio equipments



BLOCK DIAGRAM

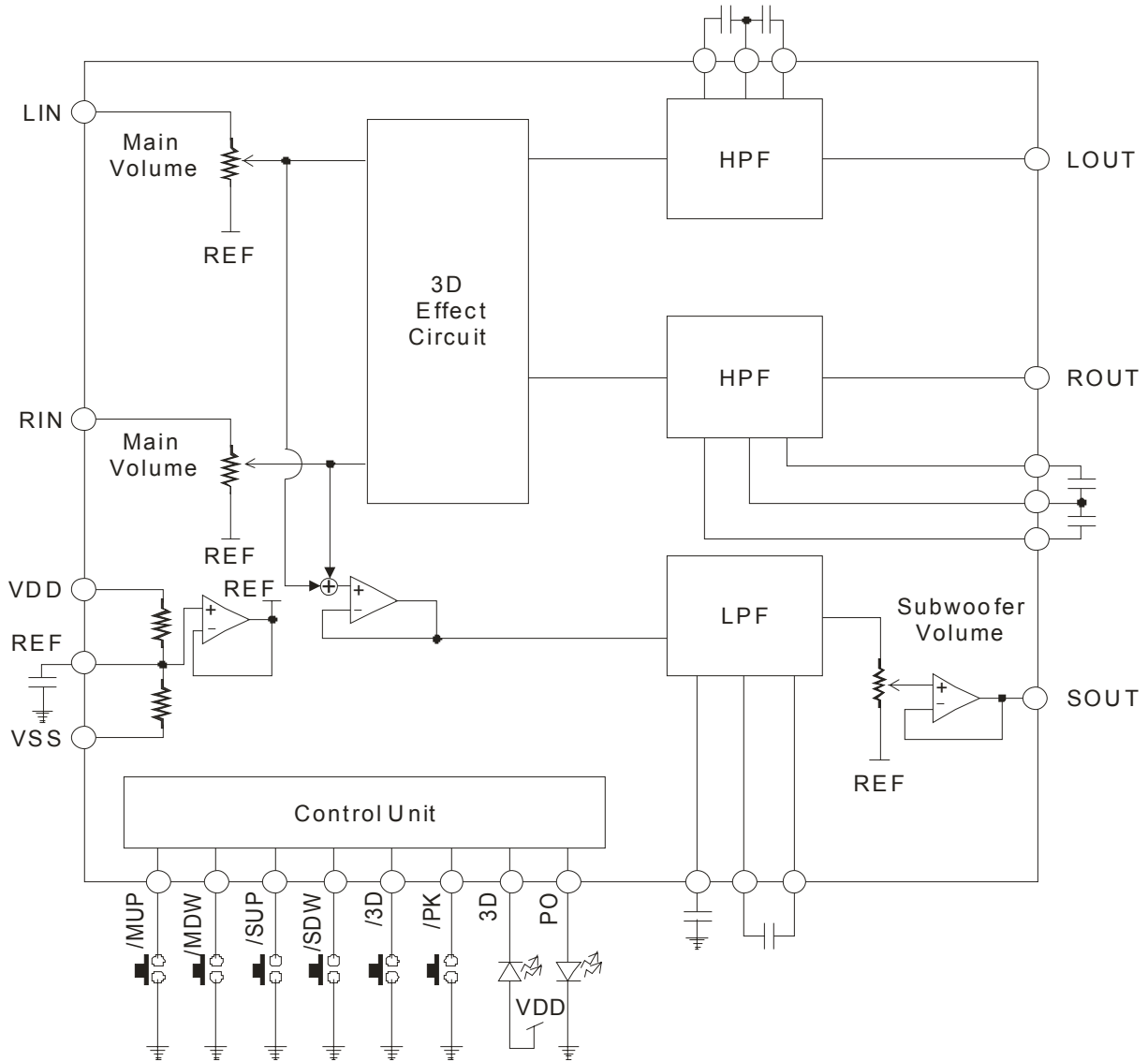



PIN CONFIGURATION

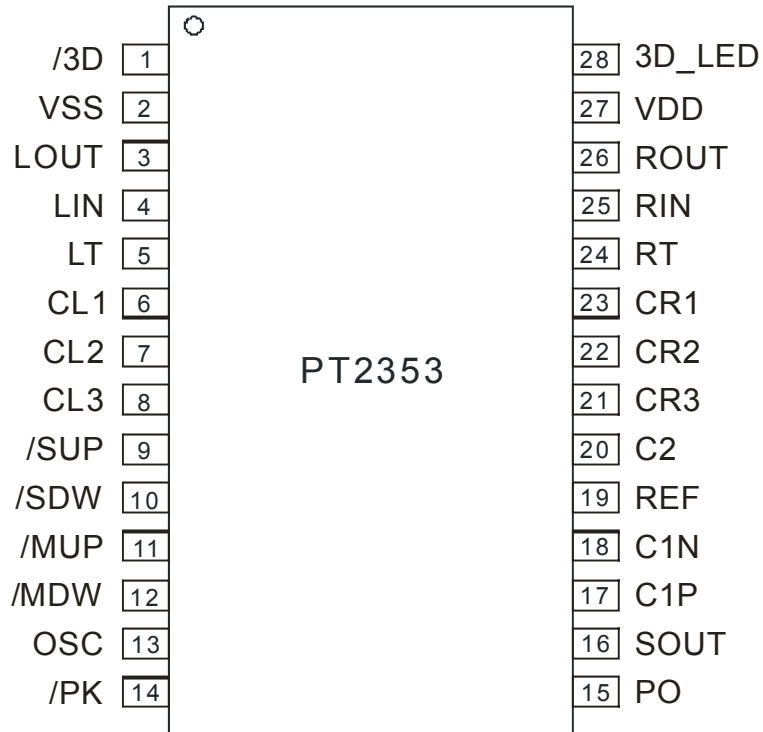



PIN CONFIGURATION

Pin Name	I/O	Description	Pin No.
/3D	I	3D Effect Enable Pin (Low: active)	1
VSS	—	Ground Pin	2
LOUT	O	Left Channel Output Pin	3
LIN	I	Left Channel Input Pin	4
LT	I	Left Channel Center Tap (Loudness) Pin	5
CL1	I	Left Channel High Pass Filter Capacitor Pin 1	6
CL2	I	Left Channel High Pass Filter Capacitor Pin 2	7
CL3	I	Left Channel High Pass Filter Capacitor Pin 3	8
/SUP	I	Subwoofer Channel Volume Up Control Pin (Low: active)	9
/SDW	I	Subwoofer Channel Volume Down Control Pin (Low: active)	10
/MUP	I	Main Volume Up Control Pin (Low: active)	11
/MDW	I	Main Volume Down Control Pin (Low: active)	12
OSC	I	Oscillation Pin (connects to external RC components)	13
/PK	I	PO Control Pin (Low: active)	14
PO	O	Power Amplifier Control Pin (controlled by PK pin 14)	15
SOUT	O	Subwoofer Channel Output Pin	16
C1P	I	Low Pass Filter External Capacitor Pin	17
C1N	I	Low Pass Filter External Capacitor Pin	18
REF	I	Reference Voltage = $\frac{1}{2}$ VDD	19
C2	I	Low Pass Filter External Capacitor Pin 2	20
CR3	I	Right Channel High Pass Filter Capacitor Pin 3	21
CR2	I	Right Channel High Pass Filter Capacitor Pin 2	22
CR1	I	Right Channel High Pass Filter Capacitor Pin 1	23
RT	I	Right Channel Volume Center Tap (Loudness) Pin	24
RIN	I	Right Channel Input Pin	25
ROUT	O	Right Channel Output Pin	26
VDD	—	Positive Power Supply	27
3D-LED	O	3D LED Indicator Pin	28



FUNCTION DESCRIPTION

VOLUME CONTROL

Both main volume control and subwoofer volume control are supported by PT2353. Please refer to the diagram below.

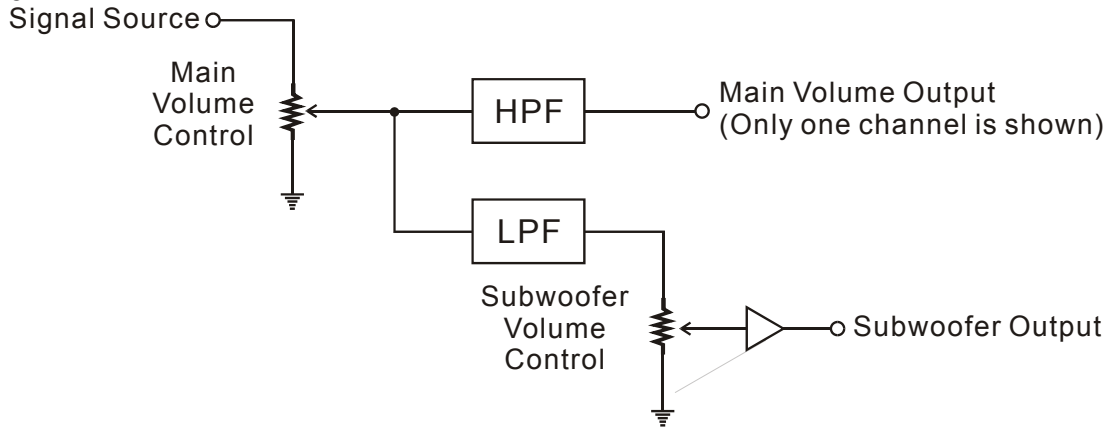

The main volume control is used to adjust all audio volume levels. The subwoofer volume control can be adjusted to match the main volume control. The Main Volume Control is determined by the /MUP and /MDW pins. If the /MUP is connected to the Ground, the main volume level output may be increased. If the /MDW is connected to the Ground, the main volume level output can be decreased.

The Subwoofer Volume Control is determined by the /SUP and /SDW pins. If the /SUP is connected to Ground, the subwoofer volume level output can be increased. If the /SDW is connected to the Ground, the subwoofer volume level output can be decreased.

When each of the /MUP, /MDW, /SUP, /SDW pins are connected to the GND for an indefinite period of time, please refer to the following diagram.

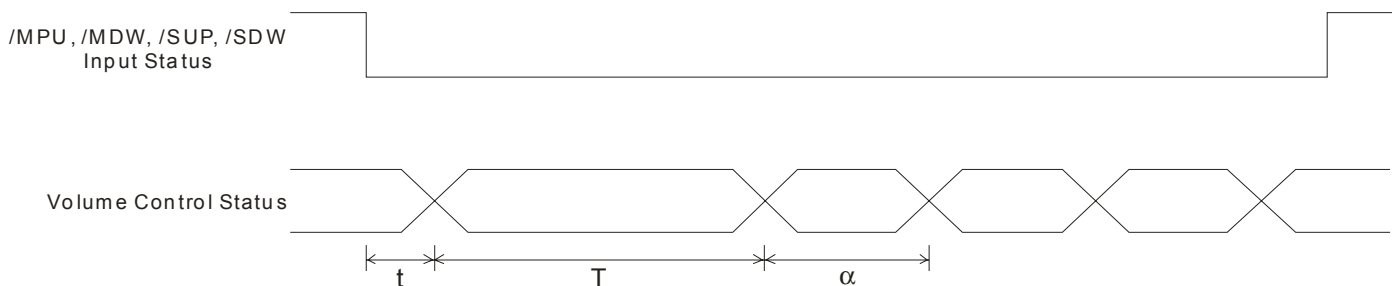

Notes:

1. t =Default Key Time
2. T =Hold Time ($10 \times 1/fosc$)
3. α =Volume UP/DOWN Switch Time ($2 \times 1/fosc$)
4. $fosc$ =Internal Oscillation Frequency



VOLUME ATTENUATION

A PT2353 volume control circuit consists of ladder resistors and analog switches. The Tap for Loudness Function (LT & RT) is connected to the Step 6 (-20dB). Therefore, the Loudness Function Effect will be clearly audible when the volume setting is less than -20dB. Please refer to the attenuation table given below.

Step	Attenuation	Step	Attenuation
0	0	16	-32
1	-2	17	-34
2	-4	18	-36
3	-6	19	-38
4	-8	20	-40
5	-10	21	-42
6	-12	22	-44
7	-14	23	-46
8	-16	24	-48
9	-18	25	-50
10	-20	26	-52
11	-22	27	-54
12	-24	28	-56
13	-26	29	-58
14	-28	30	-60
15	-30	31	∞



Satellite + Subwoofer 3-Speaker System Electronics Crossover IC

PT2353

The equivalent circuit is shown below.

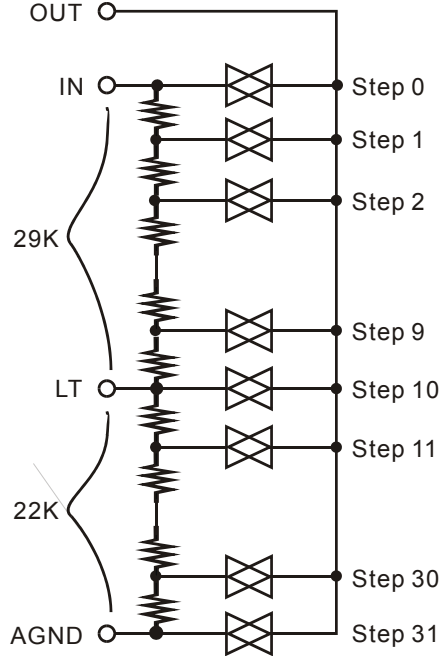

VOLUME INITIALIZATION

After power is turned ON, the volume control value of the main channel is set to the initial setting of -30dB step while the subwoofer channel will be set at 0dB.

The PT2353 loudness frequency response curve from Step 0 to Step 31 is given below.

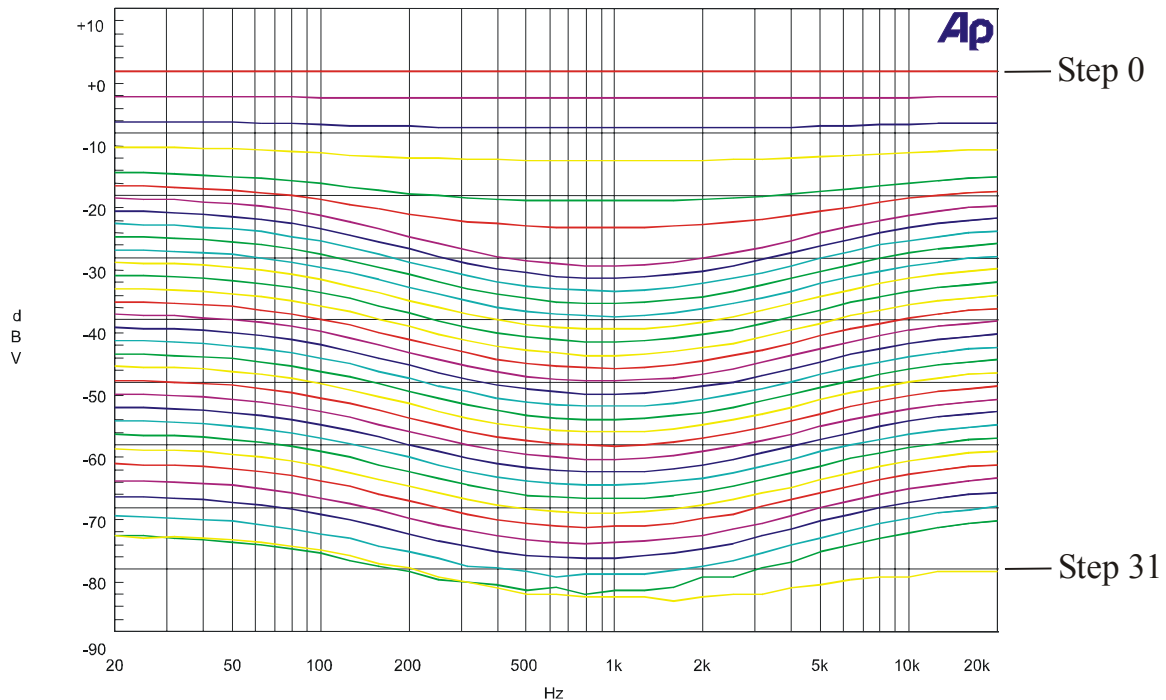



FILTER

The main channel of PT2353 includes the high pass filter which is used to filter out the main speaker's low frequency characteristics. The filtered signal is then combined with the subwoofer low pass filter characteristics. This High Pass Filter is of Sallen Key Type with a pass band gain equivalent to 0dB. Adjustment of the crossover frequency is made via the two external capacitors. Please refer to the figure below.

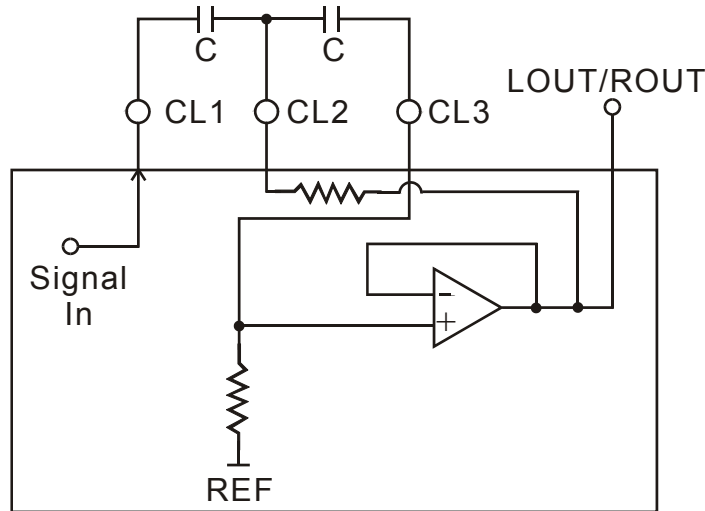

Subwoofer channel mixed from the Main Channel also uses the Sallen Key Type Low Pass Filter to filter out the high frequency characteristics. Two external capacitors can be used to adjust the crossover frequency. Please refer to the diagram below.

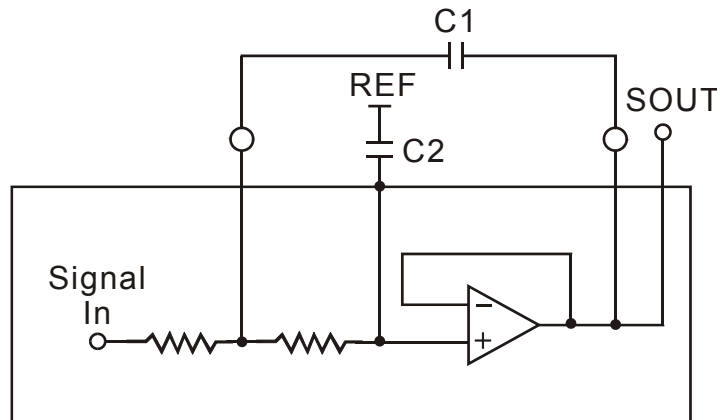



Satellite + Subwoofer 3-Speaker System Electronics Crossover IC

PT2353

The subwoofer in this 3-speaker system has only one channel output; therefore, it is recommended that the LPF must be less than 300Hz. If the frequency is greater than 300 Hz, then the audio output is can be clearly discernible. That is, it is easy to know where the sound is coming from. The following diagram provides the suggested crossover frequencies and respective external capacitors.

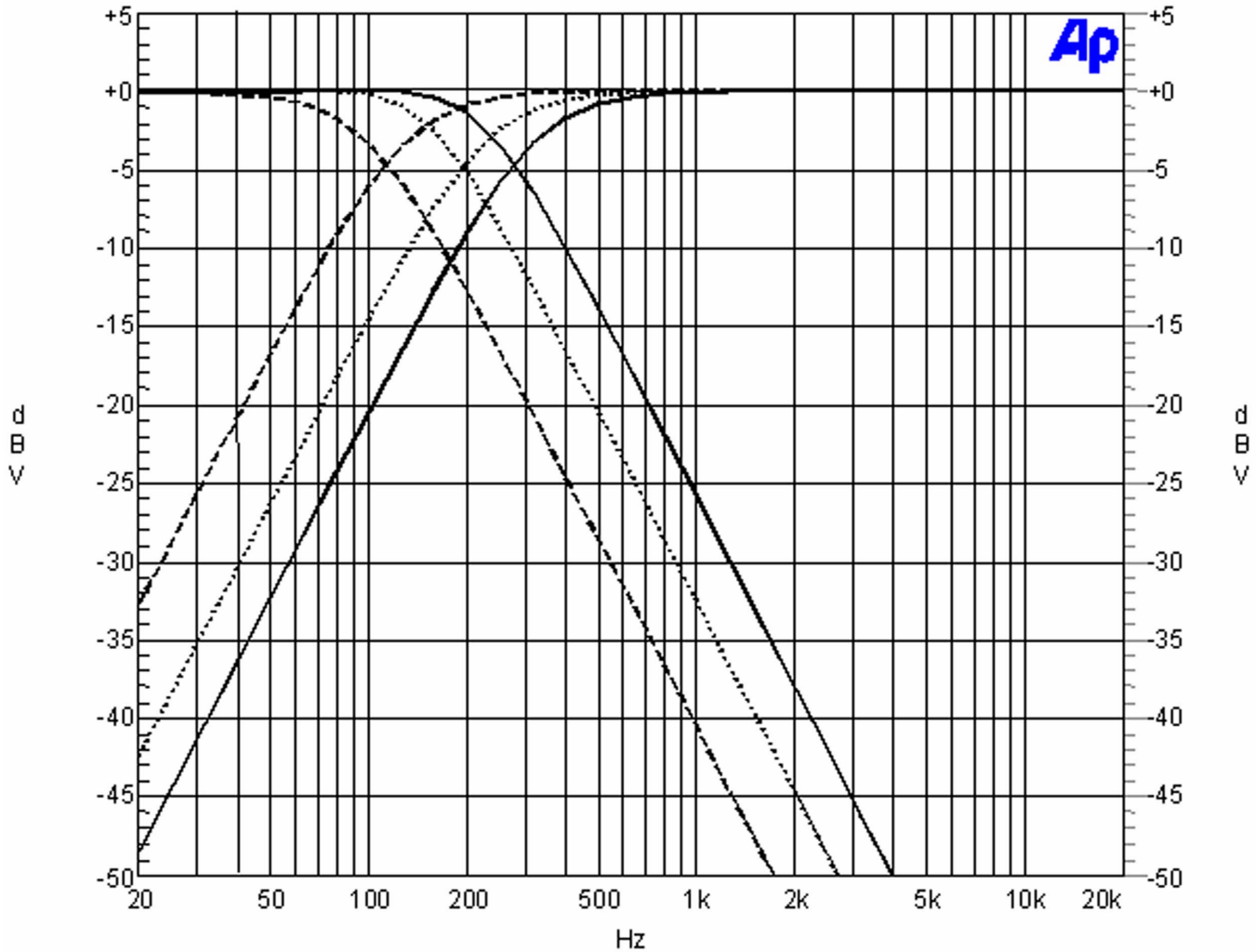

Notes:

- Crossover Frequency: 280Hz, C=0.015 μ F, C1=0.047 μ F, C2=0.018 μ F
- - - Crossover Frequency: 200Hz, C=0.022 μ F, C1=0.068 μ F, C2=0.027 μ F
- . - Crossover Frequency: 120Hz, C=0.033 μ F, C1=0.1 μ F, C2=0.047 μ F

C is the High Pass Filter External Capacitor.
C1 and C2 are the Low Pass Filter External Capacitors



3D EFFECT FUNCTION

The 3D Pin controls the 3D effect function of PT2353. It toggles between turning the 3D effect function ON or OFF. When the 3D effect function is enabled, the 3D LED is displayed. When the PO pin in low state the 3D function and 3D LED is both inhibited.

POWER CONTROL

PK (Pin 14) is the PO Control Pin and is used to toggle between activating and deactivating the PO pin (Pin 15). The power amplifier status (ON or OFF) may be controlled by connecting the external power amplifier device to the PO Pin.

After the power supply is first applied to the VDD pin of PT2353, the output state for the PO and 3D pins is LOW. During this state, all the control function keys are disabled, with the exception of the PK key. When the PK key is pressed once, the PO is set to HIGH and all the control function keys are activated.



ABSOLUTE MAXIMUM RATING

Parameter	Symbol	Rating	Unit
Operating voltage	Vs	10.2	V
Ambient temperature	Topr	-40 to +85	°C
Storage temperature	Tstg	-65 to +150	°C

ELECTRICAL CHARACTERISTICS

(Unless otherwise specified, Tamb=25°C, VDD=9V, RL=100KΩ, f=1KHz)

Parameter	Symbol	Condition	Min.	Typ.	Max.	Unit
Power supply	VDD		5	-	9.5	V
Operating current	Is	3D, PK OFF, VDD=9V 3D, PK OFF, VDD=4.5V	-	23 18	-	mA mA
Total harmonic distortion	THD	ATT=0dB, F=1KHz VIN=1Vrms, 20Hz ~ 20KHz All filters bypass, All outputs	-	0.01	-	%
		ATT=-20dB, F=1KHz VIN=1Vrms, 20Hz ~ 20KHz All filters bypass, All outputs	-	0.05	-	
Output noise	NO	ATT=0dB, VIN=0V A-weighting, All filters bypass	-	15	-	μV
Signal-to-noise ratio	S/N	0dB=1Vrms, ATT=0dB VIN=0V, A-weighting All filters bypass	-	90	-	dB
Maximum input voltage	VIMAX	f=1KHz, ATT=0dB VDD=9V	-	2.7	-	Vrms
Voltage gain	Gn	f=1KHz, ATT=0dB All Outputs	-1	0	+1	dB
Cross talk	CT	0dB=1Vrms, f=1KHz VIN=1Vrms, RL=100K RG=600Ω, A-weighting	-	-86	-	dB
Maximum volume attenuation	ATTMAX	f=1KHz, VIN=1Vrms LOUT, ROUT	-	-75	-	dB
		Main volume =Max, SOUT	-	-75	-	dB
High level input voltage	VIH		6.7	-	9	V
Low level input voltage	VIL		0	-	3.2	V
LED sink current	IS	3D LED Pin	-	6	-	mA
Drive current	IO	PO	-	5	-	mA
Output impedance	RO	Vout=100mV f=1KHz	70	100	130	Ω
Input impedance	RI		40	50	60	KΩ



APPLICATION CIRCUIT

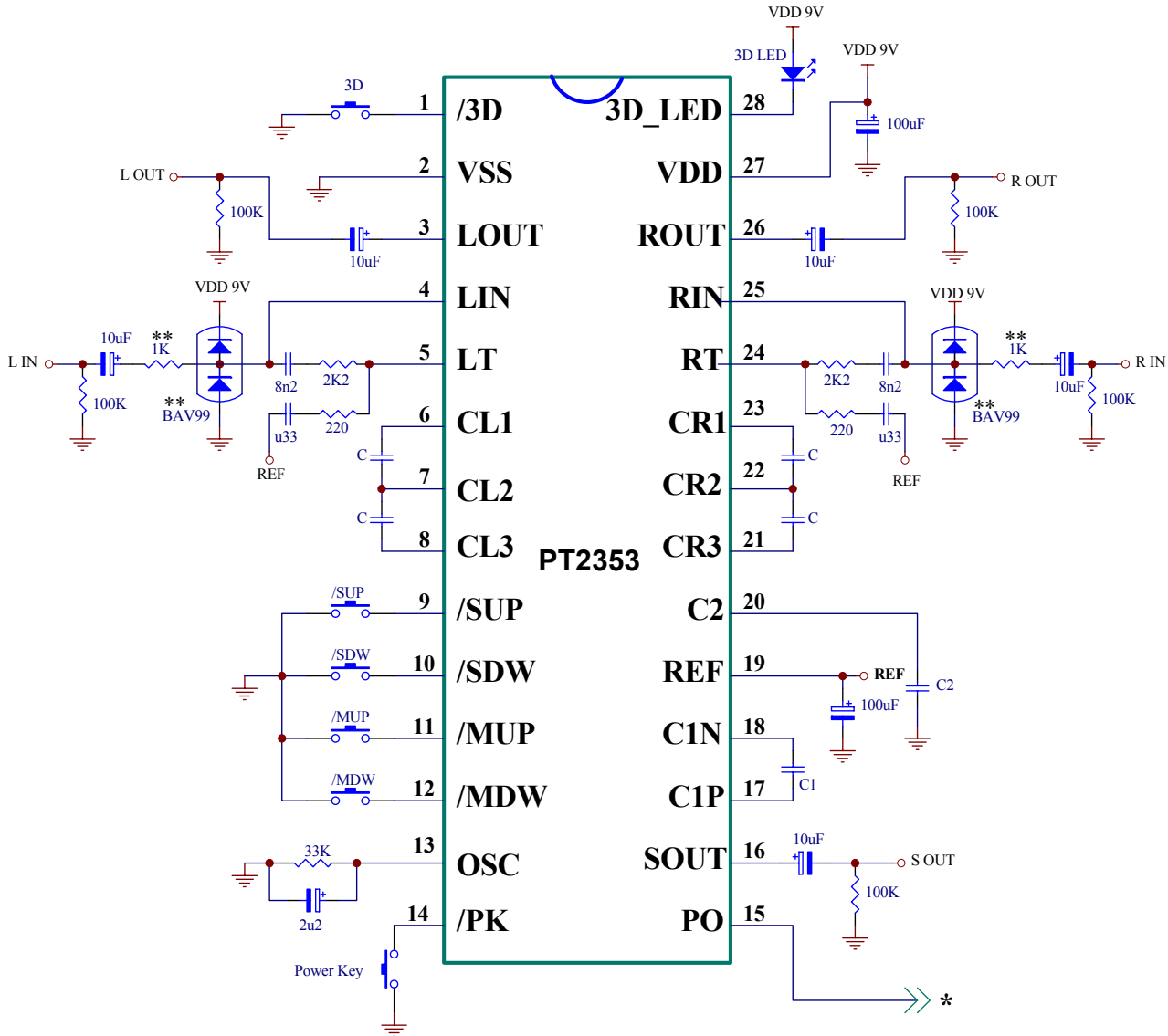

Notes:

Please refer to the PT2353 Crossover Frequency Response Curve for the values of C, C1, and C2.
Please refer to Power Control (PO) Section of this document.

** For input port high voltage pulse protection.



ORDER INFORMATION

Valid Part Number	Package Type	Top Code
PT2353	28 Pins, DIP, 600mil	PT2353
PT2353-S	28 Pins, SOP, 300mil	PT2353-S



PACKAGE INFORMATION

28 PINS, DIP, 600MIL

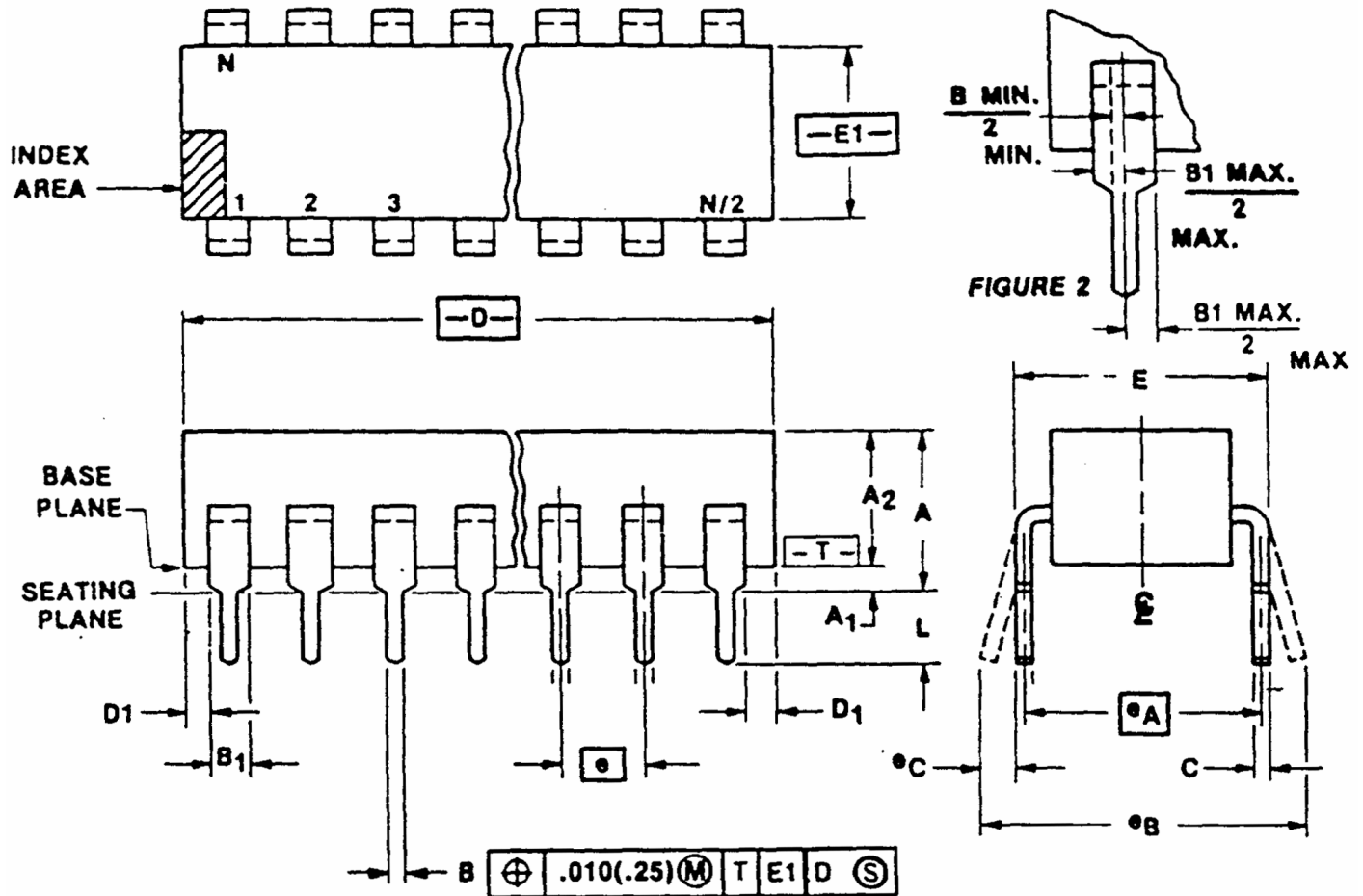



Satellite + Subwoofer 3-Speaker System Electronics Crossover IC

PT2353

Symbol	Min.	Max.
A	-	6.35
A1	0.39	-
A2	3.18	4.95
B	0.356	0.558
B1	0.77	1.77
C	0.204	0.381
D	35.1	39.7
D1	0.13	-
E	15.24	15.87
E1	13.32	14.73
e	2.54 BSC.	
eA	15.24 BSC.	
eB	-	17.78
L	2.93	5.08

Notes:

- Controlling Dimension: Millimeter
- Dimensioning and tolerancing per ANSI Y14.5M-1982.
- Dimensions "A", "A1" and "L" are measured with the package seated in JEDEC Seating Plane Gauge GS-3.
- "D" and "E1" are dimensions for plastic packages, do not include mold flash or protrusions. Mold flash or protrusions shall not exceed 0.10 inch (0.25mm).
- "E" and "A" are measured with the leads constrained to be perpendicular to plane T.
- "eB" and "oC" are measured at the lead tips with the leads unconstrained. "oC" must be zero or greater.
- N is the maximum number of terminal positions. (N=28)
- Corner leads (1, N, N/2+1) may be configured as shown in Figure 2.
- Pointed or rounded lead tips are preferred to ease insertion.
- For automatic insertion, any raised irregularity on the top surface (step, mess, etc.) shall be symmetrical about the lateral and longitudinal package centerlines.
- Please refer to JEDEC MS-011 Variation AB.

JEDEC is the trademark of JEDEC SOLID STATE TECHNOLOGY ASSOCIATION.



Satellite + Subwoofer 3-Speaker System Electronics Crossover IC

PT2353

28 PINS, SOP, 300MIL

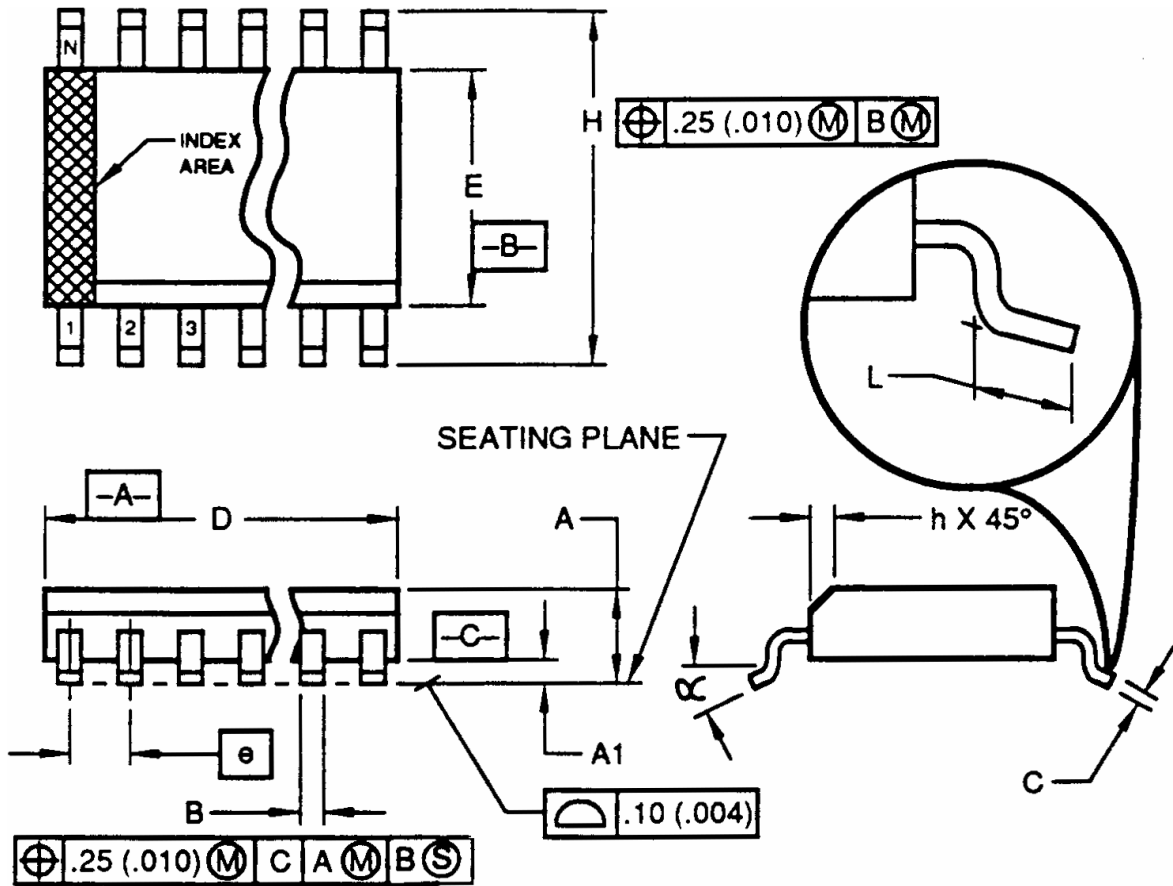

Symbol	Min.	Nom.	Max.
A	2.35		2.65
A1	0.10		0.30
B	0.33		0.51
C	0.23		0.32
D	17.70		18.10
E	7.40		7.60
e	1.27 BSC.		
H	10.00		10.65
h	0.25		0.75
L	0.40		1.27
alpha	0°		8°



Satellite + Subwoofer 3-Speaker System Electronics Crossover IC

PT2353

Notes:

1. Dimensioning and tolerancing per ANSI Y14.5-1982.
2. Dimension "D" does not include mold flash, protrusions or gate burrs. Mold Flash, protrusion or gate burrs shall not exceed 0.15mm (0.006 in) per side.
3. Dimension "E" does not include interlead flash or protrusions. Interlead flash or protrusions shall not exceed 0.25 mm (0.010 in) per side.
4. The chamfer on the body is optional. If it is not present, a visual index feature must be located within the crosshatched area.
5. "L" is the length of the terminal for soldering to a substrate.
6. "N" is the number of terminal positions. (N=28)
7. The lead width "B" as measured 0.36 mm (0.014 in) or greater above the seating plane, shall not exceed a maximum value of 0.61 mm (0.24 in).
8. Controlling dimension: Millimeter
9. Refer to JEDEC MS-013 Variation AE

JEDEC is the trademark of JEDEC SOLID STATE TECHNOLOGY ASSOCIATION.