

### FEATURES

- High engagement and high reliability with new structure
- Ultra-miniature for high density mounting (11.6mm<sup>2</sup>)
- Ultra-low profile (3.0mm max.)
- SMD and reflow solderable
- Tape and reel packaging
- Mountable by automatic placer
- High performance (VSWR: 1.2 max. at 3GHz)
- Available with ultra-thin FEP coaxial cables (0.8mm dia.)

### APPLICATIONS

Portable, mobile and cordless telephone, GPS, any other microwave radio and measurement equipment, high-end workstations

### PART NUMBERING – RECEPTACLE

Part Number	Packaging	Quantity
MM7329-2700	Bulk package	Specify
MM7329-2700TB1	178mm Dia. Taping	1000pcs/reel
MM7329-2700TB2	330mm Dia. Taping	4000pcs/reel

### PART NUMBERING – CABLE ASSEMBLY

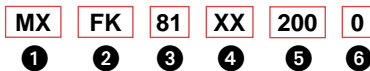

- ① Cable assembly
- ② ④ Connector code for each end of cable

Code	Connector
FG	FSC type Plug connector for 76 cable
FK	FSC type Plug connector for 81 cable
XX	No connector

- ③ Cable code

Code	Cable	Outer Diameter	Outer Conductor Construction	Minimum Bending Radius	Insulation Material
76	0.8D	1.25mm	Single shield	6mm	FEP or PFA
81	0.4D	0.8mm	Single shield	4.8mm	FEP or PFA

- ⑤ ⑥ Full length of cable assembly  
Length L (mm) = ⑤ × 10<sup>⑥</sup>  
Ex. 500mm = 500 × 10<sup>0</sup> = 5000  
1000mm = 100 × 10<sup>1</sup> = 1001

### SPECIFICATIONS

Item	Rating and Characteristics
Frequency	From DC to 3GHz
VSWR	1.2 max.
Nominal Impedance	50Ω
Temperature Range	-40°C to +90°C
Voltage	250Vrms
Contact Resistance	15mΩ max.
Withstand Voltage	300VAC rms
Insulation Resistance	500MΩ min.
Mating Cycles	50 cycles

### DIMENSIONS (MM7329-2700): mm

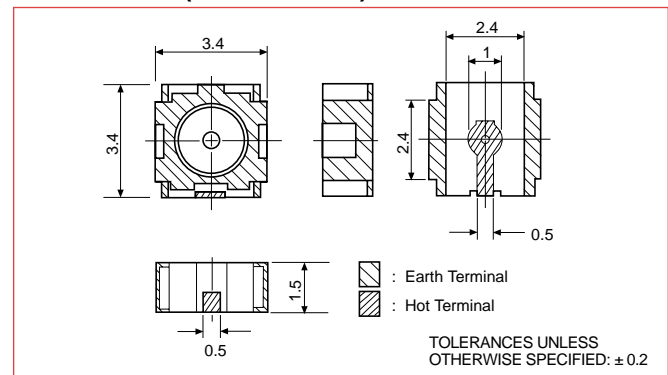

### DIMENSIONS (MXFK81□□□□□□): mm (MXFG76□□□□□□)

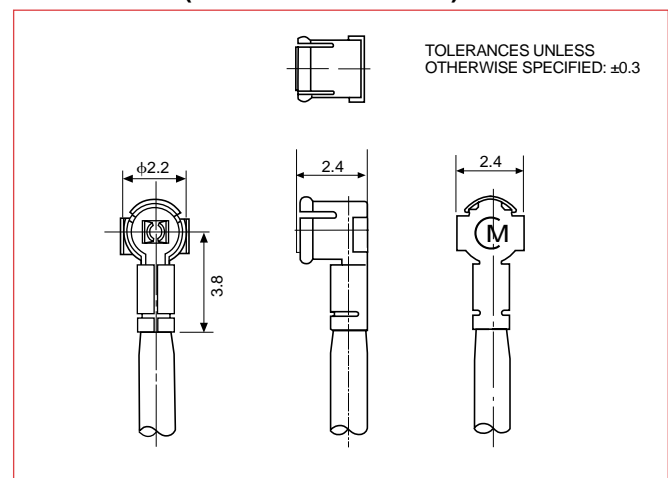

### MATERIALS AND FINISH MM7329-2700 – RECEPTACLE

Part Name	Materials	Finish
Center Contact	Copper Alloy	Gold plated
Outer Contact	Copper Alloy	Gold plated
Insulator	Engineering Plastic	None

### MXFK81□□□□□□ – CONNECTOR MXFG76□□□□□□ – CONNECTOR

Part Name	Materials	Finish
Center Contact	Copper Alloy	Gold plated
Outer Contact	Copper Alloy	Gold plated
Insulator	Engineering Plastic	None

### CABLE LENGTH TOLERANCE

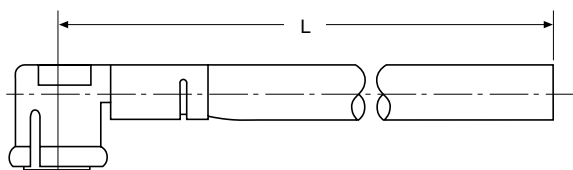

Cable Length L (mm)*		Dimensional Tolerance (mm)
From	To	
40	100	± 3
100	500	± 4
500	1000	±10
1000	—	+2% of L -0% of L

\*L must be 40mm min.

### DIMENSIONS OF PLASTIC TAPE: mm

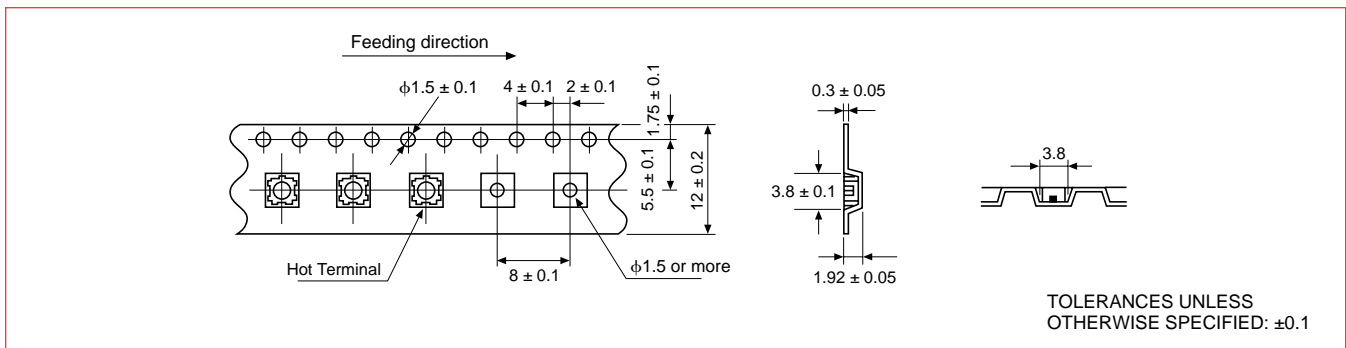

### RECOMMENDED MOUNTING DIMENSIONS: mm

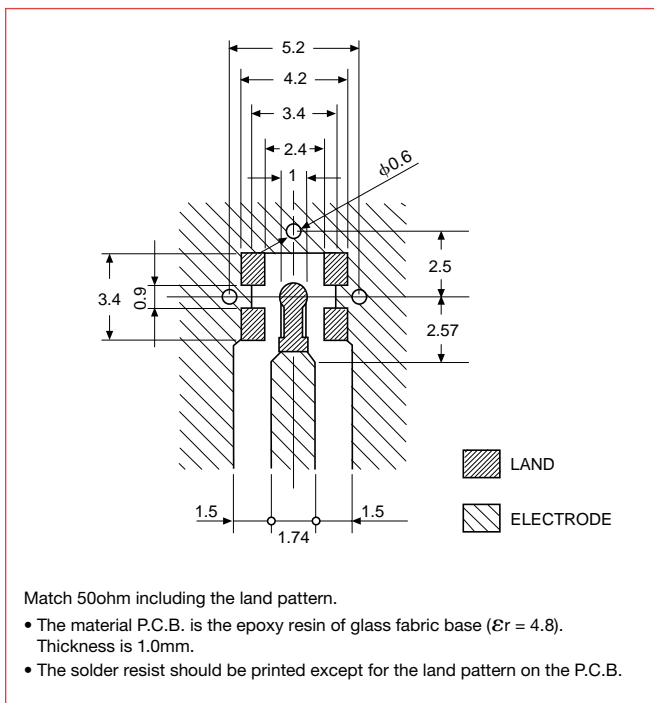

### DIMENSIONS: mm

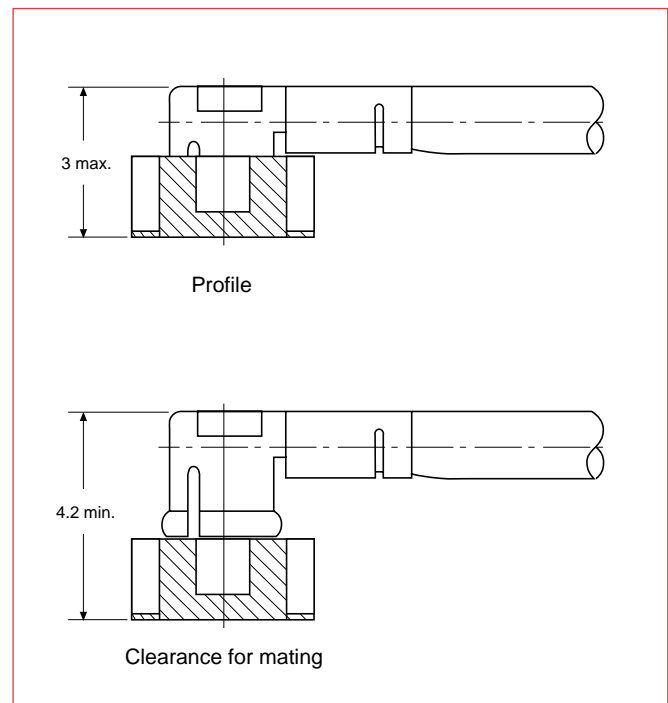

HIGH FREQUENCY DEVICES

### APPLICATION NOTES

- Stress limit to the connector: When connected, stress to the connector should be limited as shown in Fig. 1.
- PCB mounting pattern dimensions: Dimensions shown on page 323 "Recommended Mounting Dimensions" should be used for PCB design.
- Disengagement and engagement: Use tool P/N M19000. The connector to be disengaged and engaged should be pulled out or insert to the vertical direction using the tool. Do not try and pull out the cable by hand or wire breakage may result.
- Cable and connector handling: Do not apply a twisting torque to the cable and connector.
- REFLOW SOLDERING CONDITION: Reflow soldering should be carried out according to condition shown in Fig. 4.

### STRESS TO THE CONNECTOR (Fig. 1)

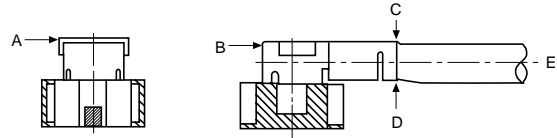

1. Stress to the housing.  
Stress A and B: 4.9N (0.5kgf) max.
2. Stress to the outer sleeve.  
Stress C: 2.94N (0.3kgf) max.  
Stress D: 1.96N (0.2kgf) max.
3. Stress to the cable.  
Stress E: 4.9N (0.5kgf) max. for 81 cable  
7.84N (0.8kgf) max. for 76 cable

### DISENGAGEMENT TOOL (Fig. 2): mm

#### M19000

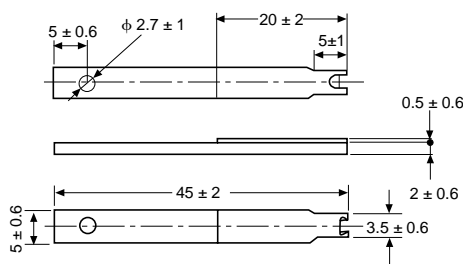

### How to use disengagement tool

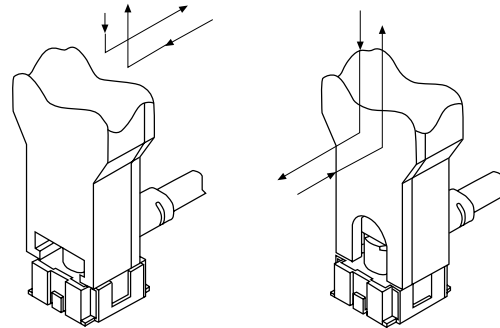

### SMA-FSC ADAPTERS (Fig. 3): mm

#### MM121460 (For FSC type receptacle)

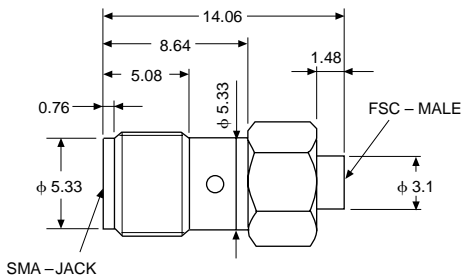

#### MM121454 (For FSC type cable assembly)

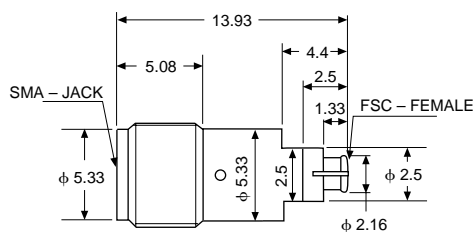

### STANDARD REFLOW SOLDERING CONDITIONS (Fig. 4)

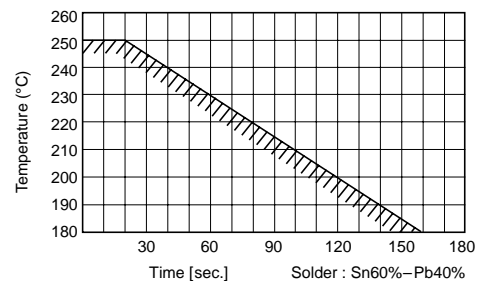

### Allowable temperature and time of reflow soldering

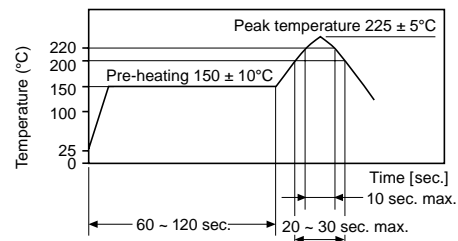

- Measuring point of temperature in-out terminals of the device.
- Reflow Soldering
- Both convection and infrared rays
- Hot air
- Hot plate

## SPECIFICATIONS

SPECIFICATIONS			76	81	92
Description			0.8D Single shield outer conductor with FEP insulation, based on JIS C 3501	0.4 Single shield outer conductor with FEP insulation, based on JIS C 3501	0.4 Single shield outer conductor PFA cable based on JIS C 3501
Inner conductor	Material	—	Silver-coated copper-covered steel wire	Silver-coated copper-covered steel wire	Silver-coated copper-covered steel wire
	No. and Dia.	(No./mm)	1/0.26	7/0.05	1/0.15
	Dia.	(mm)	0.26	0.15	0.15
Insulation	Material	—	FEP	FEP or PFA	PFA
	Softening point	°C (typ.)	285	250	302-310
	Dia.	(mm)	0.8	0.4	0.43
Outer Conductor	Material	—	Single braid of tin-coated copper wire	Single braid of tin or silver-coated copper wire	Tin plated copper wire
	Carriers	—	16	16	8
	Ends	—	5	5	3
	Dia. of wire	(mm)	0.05	0.05	0.05
Sheath	Material	—	FEP	FEP or PFA	PFA
	Nominal thick.	(mm)	0.1	0.05	0.075
Overall Dia.			(mm)	1.25	0.83
Nominal impedance		(Ω)	50	50	50
Continuous working voltage			300V rms, maximum	300V rms, maximum	300V rms, maximum
Nominal capacitance		(pF/m)	100	100	100
Nominal attenuation	dB/km at 1GHz		1560	3000	2.89
	dB/km at 2 GHz		2300	4260	4.28
	dB/km at 3GHz		2900	5240	5.39
	dB/km at 4GHz		3500	6180	6.44
Velocity Factor			2.09 x 10 <sup>8</sup> m/s*	2.09 x 10 <sup>8</sup> m/s*	2.09 x 10 <sup>8</sup> m/s*

\*Meters per second