

CMOS Dual Channel UART (DUART)

GENERAL DESCRIPTION

The EXAR Dual Universal Asynchronous Receiver and Transmitter (DUART) is a data communications device that provides two fully independent full duplex asynchronous communications channels in a single package. The DUART is designed for use in microprocessor bases systems and may be used in a polled or interrupt driven environment.

Two basic versions of the DUART are available, each optimized for use with various microprocessor families: XR- 88C681 for 8080/85, 8086/88, Z80, Z8000, 68xx and 65xx family based systems, and the XR-68C681 for 68000 family based systems. A programmable mode of the XR- 88C681 version provides an interrupt daisy chain capability for use in Z80 and Z8000 based systems. However, the bus interfaces are general enough to allow interfacing with other microprocessors and microcontrollers. The XR-88C681 and XR-68C681 are enhanced versions of the Signetics, Motorola 2681 and 68681 respectively with tighter electrical specifications, and are pin and function compatible with those devices.

The DUART is fabricated using advanced two-layer metal high density CMOS process to provide high performance and low power consumption and is packaged in a 40 pin DIP. The XR-88C681 is also available in a 28 pin DIP.

FEATURES

Full Duplex, Dual Channel, Asynchronous Receiver and Transmitter
 Quadruple-Buffered Receiver, Dual-Buffered Transmitter
 Stop Bits Programmable in 1/16-bit Increments
 Internal Bit Rate Generator with 23 Bit Rates
 Independent Bit Rate Selection for Each Receiver and Transmitter

Maximum Bit Rate: 1x Clock - 1 Mb/Sec,
 16x Clock - 125Kb/Sec
 Normal, Autoecho, Local Loopback, and Remote Loopback Modes
 Multi-Function 16-Bit Counter/Timer
 Interrupt Output with Eight Maskable Interrupting Cond.
 Interrupt Vector Output on Acknowledge
 Programmable Interrupt Daisy Chain
 Up to 15 I/O Pins (Depending on Package and Version)
 Change of State Detectors on Inputs
 Multidrop Mode Compatible with 8051 Nine-Bit Mode
 On-Chip Oscillator for Crystal
 Standby Mode to Reduce Operating Power
 Advanced CMOS Low Power Technology

3

ABSOLUTE MAXIMUM RATINGS

Storage Temperature 65°C to + 150°C
 All Voltages with Respect to Ground 0.5 V to + 7.0 V

ORDERING INFORMATION

XR-88C681/40XX, XR-88C681/28XX, XR-88C681/24XX* and XR-68C681XX are offered in the following packages:

XX=Suffix Temperature	Package	Operating
CN	Ceramic	0°C to + 70°C
N	Ceramic	-40°C to + 85°C
M	Ceramic	-55°C to + 125°C
CP	Plastic	0°C to 70°C
P	Plastic	-40°C to 85°C
CJ	PLCC	0°C to 70°C
J	PLCC	-40°C to 85°C

For pin assignments, refer to the end of this datasheet

XR-88C681/68C681

SYSTEM DESCRIPTION

Each channel of the DUART may be independently programmed for operating mode and data format. The operating speed of each receiver and transmitter can be selected from one of 23 internally generated fixed bit rates, from a clock derived from an internal counter/timer, or from an external 1x or 16x clock. The bit rate generator can operate directly from a crystal

connected across two pins or from an external clock. The ability to independently program the operating speed of the receiver and transmitter of each channel makes the DUART attractive for split-speed channel applications such as clustered terminal systems.

BLOCK DIAGRAM - XR-88C681

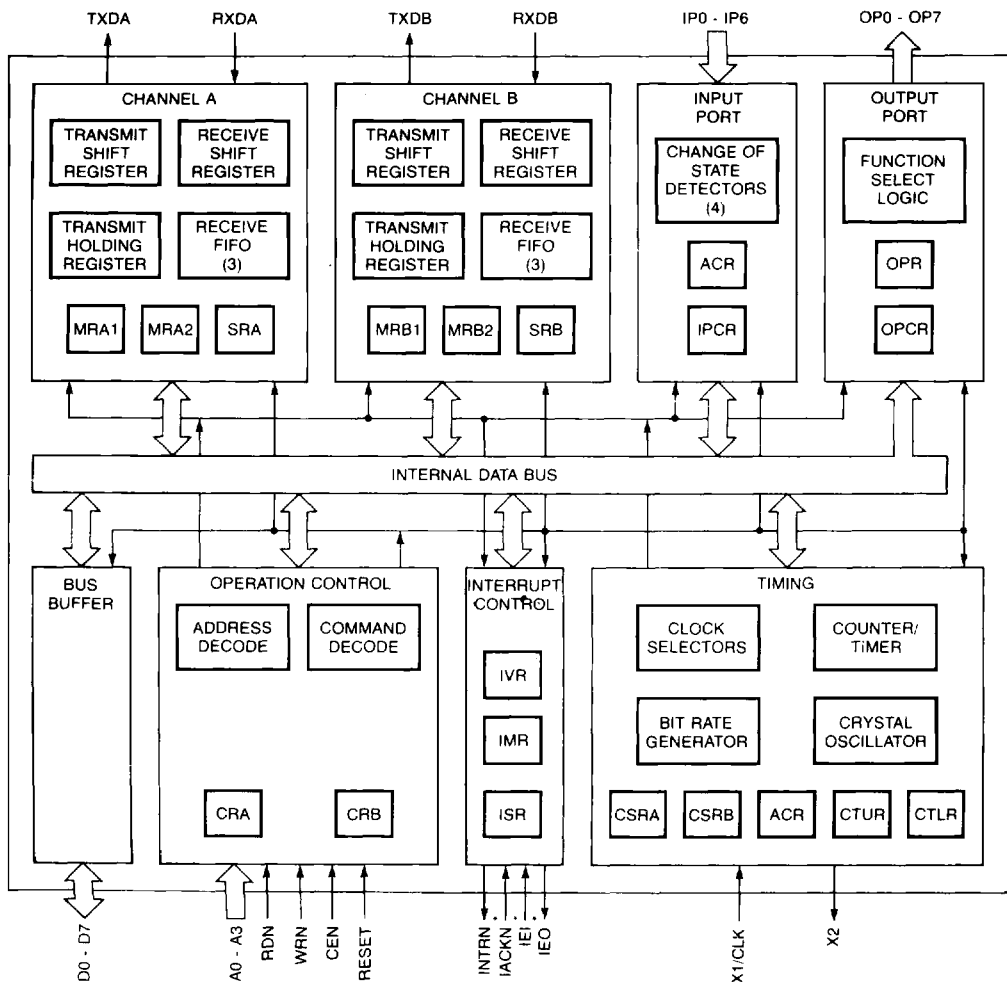

* ALTERNATE FUNCTIONS FOR IP4 - IP6

Received data is quadruple-buffered in an on-chip FIFO to minimize the risk of receiver overrun or to reduce overhead in interrupt-driven applications. The DUART also provides a flow control capability to inhibit transmission from a remote device when the buffer of the receiving DUART is full, thus preventing loss of data.

The DUART also provides a general purpose 16-bit

counter/timer (which may also be used as a programmable bit rate generator), a multi-purpose input port and a multipurpose output port. These ports can be used as general purpose I/O ports or can be assigned specific functions such as clock inputs or status/interrupt outputs under program control.

BLOCK DIAGRAM - XR-68C681

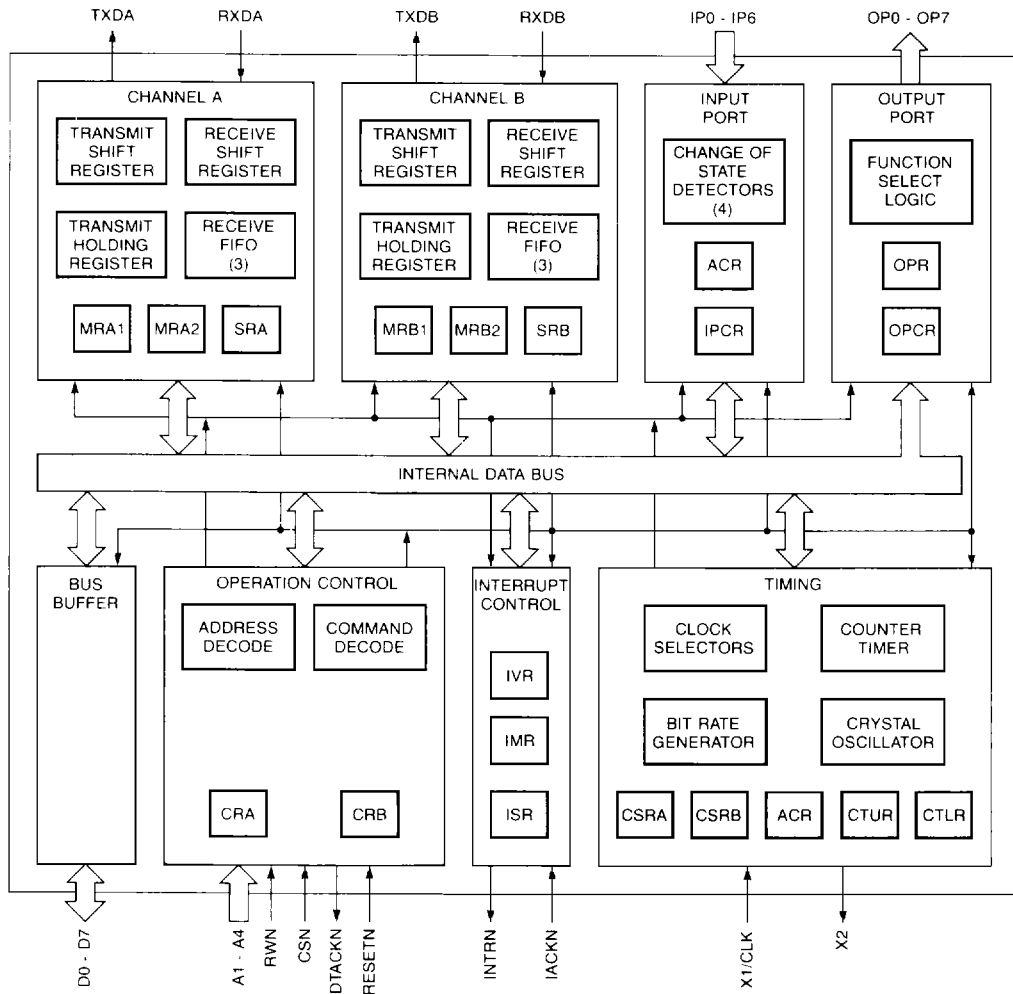

XR-88C681/68C681

DC ELECTRICAL CHARACTERISTICS

TA = 0°C to +70°C, V_{CC} = 5.0V + 5% 3, 4, 15 unless otherwise specified

Symbol	Parameter	Limits			Units	Test Conditions
		Min.	Typ.	Max.		
V _{IL}	Input Low Voltage	-0.5		0.8	V	
V _{IH}	Input High Voltage (except X1/CLK)	2.0		V _{CC}	V	
V _{IH} ¹⁵	Input High Voltage	2.2				T _A = -55°C to 125°C
V _{IHI}	Input High Voltage (X1/CLK)	4.0		V _{CC}	V	
V _{OL}	Output Low Voltage			0.4	V	I _{OL} = 2.4 mA
V _{OH}	Output High Voltage (except open drain outputs)	2.4			V	I _{OH} = -400 μA
I _{IL}	Input Leakage Current (except X1 /CLK, X2)	-10		10	μA	V _{IN} = 0 to V _{CC}
I _{X1L}	X1 Input Low Current		-4		mA	V _{IN} = 0
I _{X2L}	X2 Input Low Current		-30		μA	V _{IN} = V _{CC}
I _{X1H}	X1 Input High Current		0.2		mA	V _{IN} = V _{CC}
I _{X2H}	X2 Input High Current		30		μA	V _{IN} = V _{CC}
I _{LL}	Data Bus 3-State Leakage Current	-10		10	μA	V _O = 0 to V _{CC}
I _{OC}	Open Drain Output Leakage Current	-10		10	μA	V _O = 0 to V _{CC}
I _{CCA}	Power Supply Current ⁵		7	10	mA	Active mode
I _{CCS}	Power Supply Current ⁵		6	10	mA	Standby mode

AC ELECTRICAL CHARACTERISTICS

TA = 0°C to +70°C, V_{CC} = 5.0V ± 5% 3, 4, 6

Symbol	Parameter	Limits			Units
		Min.	Typ.	Max.	
Reset Timing (Figure 4)					
t _{RES}	RESET Pulse Width	1.0			μs
XR88C681 Read and Write Cycle Timing (Figures 5 and 6) 7					
t _{AS}	A0-A3 Setup Time to RDN, WRN Low	10			ns
t _{AH}	A0-A3 Hold Time from RDN, WRN High	0			ns
t _{CS}	CEN Setup Time to RDN, WRN Low	0			ns
t _{CH}	CEN Hold Time form RDN, WRN High	0			ns
t _{RW}	RDN, WRN Pulse Width	200			ns
t _{DD}	Data Valid from RDN Low			160	ns
t _{DF}	Data Bus Floating form RDN High	10		90	ns
t _{DS}	Data Setup Time to WRN High	90			ns
t _{DH}	Data Hold Time for WRN High	5			ns
t _{RWD}	High Time Between Reads and/or Writes 8,9	180			ns
XR88C681 Z-mode Interrupt Cycle Timing (Figure 6)					
t _{DIO}	IEO Delay Time from IEI			90	ns
t _{IAS}	IACKN Setup Time to RDN Low	Note 10			ns
t _{IAH}	IACKN Hold Time for RDN High	0			ns
t _{EIS}	IEI Setup Time to RDN Low	45			ns
t _{EOD}	IEO Deay me from INTRN Low			90	ns

Notes: See page 23

XR-88C681/68C681

AC ELECTRICAL CHARACTERISTICS continued

$T_A = 0^\circ\text{C}$ to $+70^\circ\text{C}$, $V_{CC} = 5.0\text{V} \pm 5\%$ 3,4,6

Symbol	Parameter	Limits			Units
		Min.	Typ.	Max.	
XR68C681 Read, Write and Interrupt Cycle Timing (Figures 7, 8, 9)					
t_{AS}	A1-A4 Setup Time to CSN Low	10			ns
t_{AH}	A1-A4 Hold Time from CSN High	0			ns
t_{RWS}	RWN Setup Time to CSN Low	0			ns
t_{RWH}	RWN Hold Time from CSN High	0			ns
t_{CSW}	CSN High Pulse width 9, 11	90			ns
t_{CSD}	CSN or IACKN High from DTACKN Low 12	10			ns
t_{DD}	Data Valid from CSN or IACKN Low			160	ns
t_{DF}	Data Bus Floating from CSN or IACKN High	10		90	ns
t_{DS}	Data Setup Time to CLK High	90			ns
t_{DH}	Data Hold Time from CSN High	0			ns
t_{DAL}	DTACKN Low from Read Data Valid	0			ns
t_{DCR}	DTACKN Low (Read Cycle) from CLK High			110	ns
t_{DCW}	DTACKN Low (Write Cycle) from CLK High			110	ns
t_{DAH}	DTACKN High from CSN or IACKN High			90	ns
t_{DAT}	DTACKN High Impedance from CSN or IACKN High			110	ns
t_{CSC}	CSN or IACKN Setup Time to High ¹³	80			ns
Port Timing (Figure 10) ⁷					
t_{PS}	Port Input Setup Time to RDN/CSN Low	0			ns
t_{PH}	Port Input Hold Time from RDN/CSN High	0			ns
t_{PD}	Port Output Valid from WRN/CSN High			350	ns
Interrupt Output Timing (Figure 11)					
t_{IR}	INTRN or OP3-OP7 When Used As Interrupts High from				
	Clear of Interrupt Status Bit in ISR or IPCR			270	ns
	Clear of Interrupt Mask Bit in IMR			270	ns
Clock Timing (Figure 12)					
t_{CLK}	X1/CLK (External) High or Low Time	100			ns
f_{CLK}	X1/CLK Crystal or External Frequency	2.0	3.6864	4.0	MHz
t_{CTC}	Counter/Timer External Clock High or Low Time (IP2)	100			ns
f_{CTC}	Counter/Timer External Clock Frequency (IP2)	0		4.0	MHz
t_{RTX}	RXC and TXC (External) High or Low Time ¹⁴	220			ns
f_{RTX}	RXC and TXC (External) Frequency				
	16x	0		2.0	MHz
	1x	0		1.0	MHz
Transmitter Timing (Figure 13)					
t_{TXD}	TXD Output Delay from TXC (External) Low			315	ns
t_{TCS}	TXD Output Delay from TXC (Internal) Output Low	0		135	ns
Receiver Timing (Figure 14)					
t_{RXS}	RXD Data Setup Time to RXC (External High)	210			ns
t_{RXH}	RXD Data Hold Time from RXC (External) High	180			ns

Note: See page 23

XR-88C681/68C681

PIN DESCRIPTIONS - XR-88C681

Mnemonic	Type	Description
D0-D7	I/O	8-bit Bidirectional Three-state Data Bus. Bit 0 is the LSB and bit 7 is the MSB. All transfers between the CPU and the DUART take place over this bus. The bus is three-stated when the CEN input is high, except during an IACKN cycle in the Z-mode.
A0-A3	I	Address Inputs. These inputs select the DUART register or port for the current read/write operation.
CEN	I	Chip Enable. Active low. The data bus is three-stated when CEN is high. Transfers between the CPU and the DUART via D0-D7 are enabled when CEN is low.
WRN	I	Write Strobe. Active low. A low on this input while CEN is also low writes the contents of the data bus into the addressed destination. The transfer occurs on the rising edge of WRN.
RDN	I	Read Strobe. Active low. A low on this input while CEN is also low places the contents of the addressed source on the data bus. The transfer begins on the falling edge of RDN.
RESET	I	Master Reset. A high on this pin clears internal registers (SRA, SRB, IMR, ISR, OPR, OPCR), initializes the IVR to OFH, stops the counter/timer, puts OP0-OP7 in the high state, and places both serial channels in the inactive state with the TXDA and TXDB outputs marking (high).
INTRN	O	Interrupt Request. Active low, open drain. INTRN is asserted upon the occurrence of one or more of the chip's maskable interrupting conditions.
X1/CLK	I	Crystal or External Clock Input. This pin is the connection for one side of the crystal and a capacitor to ground when the internal oscillator is used (see figure 12). If the oscillator is not used, an external clock signal must be supplied at this input.
X2	I	Crystal Input. Connection for other side of the crystal. If the oscillator is used a capacitor must also be connected from this pin to ground. This pin may be connected to ground or left open if an external clock is supplied at X1/CLK.
RXDA,RXDB	I	Receiver Serial Data Inputs. The least significant bit is received first. If external receiver clock is specified, the data is sampled on the rising edge of the clock.
TXDA,TXDB	O	Transmitter Serial Data Outputs. The least significant bit is transmitted first. Held in the marking (high) state when the transmitter is idle or disabled or when the channel operates in local loopback mode. If external transmitter clock is specified, the data is shifted out on the falling edge of the clock.
OP0	O	Output 0. Can be programmed as a general purpose output or as the channel A request-to-send output (RTSAN). Active low.
OP1	O	Output 1. Can be programmed as a general purpose output or as the channel B request-to-send output (RTSBN). Active low.

Mnemonic	Type	Description
OP2	O	Output 2. Can be programmed as a general purpose output, the channel A transmitter 1x or 16x clock output, or the channel A receiver 1x clock output. Active low. (40-pin package only).
OP3	O	Output 3. Can be programmed as a general purpose output, the channel B transmitter 1x clock output, the channel B receiver 1x clock output, or an open drain counter/timer low. (40-pin package only).
OP4	O	Output 4. Can be programmed as a general purpose output or as an open drain channel A RXRDY/FFULL output. Active low.(40-pin package only).
OP5	O	Output 5. Can be programmed as a general purpose output or as an open drain channel B RXRDY/FFULL output. Active low. (40-pin package only).
OP6	O	Output 6. Can be programmed as a general purpose output or as an open drain channel A TXRDY output. Active low. (40-pin package only).
OP7	O	Output 7. Can be programmed as a general purpose output or as an open drain channel B TXRDY output. Active low. (40-pin package only).
IP0	I	Input 0. General purpose input or CTSAN, the channel A active low clear-to-send input. (40-pin package only).
IP1	I	Input 1. General purpose input or CTSBN, the channel B active low clear-to-send input. (40-pin package only).
IP2	I	Input 2. In the 40-pin package version, when configured in 1-mode, IP2 is a general purpose input or the counter/timer external clock input. When configured in Z-mode, IP2 is a general purpose input, the counter/timer external clock input, or the channel B transmitter and receiver external clock input. In the 28-pin package version, IP2 is a multi-purpose input. It can be used as a general purpose input, the channel A and B receiver and transmitter external clock input, or as the external clock input for the counter/timer.
IP3	I	Input 3. When configured in 1-mode, IP3 is a general purpose input or the channel A transmitter external clock input. When configured in Z-mode, IP3 is a general purpose input or the channel A transmitter and receiver external clock input. (40-pin package only).
IP4/IEI	I	Input 4 or Interrupt Enable Input. When configured in I-mode, this pin is a general purpose input or the channel A receiver external clock input (IP4). When configured in Z-mode, this pin is the interrupt enable active high input (IEI). (40-pin package only).
IP5/IEO	I/O	Input 5 or Interrupt Enable Output. When configured in I-mode, this pin is a general purpose input or the channel B transmitter external clock input (IP5). When configured in Z-mode, this pin is the interrupt enable active high output (IEO). (40-pin package only).
IP6/IACKN	I	Input 6 or Interrupt Acknowledge Input. When configured in I-mode, this pin is a general purpose input or the channel B receiver external clock input (IP6). When configured in Z-mode, this pin is the interrupt acknowledge active low input (IACKN). (40-pin package only).
V _{CC}	I	+5 Volt Power Input.
GND	I	Signal and Power Ground.

XR-88C681/68C681

PIN DESCRIPTIONS - XR-68C681

Mnemonic	Type	Description
D0-D7	I/O	8-bit Bidirectional Three-state Data Bus. Bit 0 is the LSB and bit 7 is the MSB. All transfers between the CPU and the DUART take place over this bus. The bus is three-stated when the CSN input is high, except during an IACKN cycle.
A1-A4	I	Address Inputs. These inputs select the DUART register or port for the current read/write operation.
CSN	I	Chip Select. Active low. The data bus is three-stated when CSN is high. Transfers between the CPU and the DUART via D0-D7 are enabled when CSN is low.
R/WN	I	Read/Write. A high input while CSN is low indicates a read cycle while a low input while CSN is also low indicates a write cycle.
DTACKN	O	Data Transfer Acknowledge. Three-state, active low. Assertion of DTACKN indicates that data is present on the bus during a read or interrupt acknowledge cycle and that the data from the bus has been written into the addressed destination during a write cycle.
RESETN	I	Master Reset. A low on this pin clears internal registers (SRA, SRB, IMR, ISR, OPR, OPCR), initializes the IVR to OFH, stops the counter/timer, puts OP0-OP7 in the high state, and places both serial channels in the inactive state with the TXDA and TXDB outputs marking (high).
INTRN	O	Interrupt Request. Active low, open drain. INTRN is asserted upon the occurrence of one or more of the chip's maskable interrupting conditions.
IACKN	I	Interrupt Acknowledge. Active low. Assertion of IACKN indicates that the current bus cycle is an interrupt acknowledge cycle. If the DUART has an interrupt active, it responds by placing the interrupt vector on the data bus and asserting DTACKN.
X1/CLK	I	Crystal or External Clock Input. This pin is the connection for one side of the crystal and a capacitor to ground when the internal oscillator is used (see figure 12). If the oscillator is not used an external clock signal must be supplied at this input.
X2	I	Crystal Input. Connection for other side of the crystal. If the oscillator is used a capacitor must also be connected from this pin to ground. This pin may be connected to ground or left open if an external clock is supplied at X1/CLK.
RXDA,RXDB	I	Receiver Serial Data Inputs. The least significant bit is received first. If external receiver clock is specified, the data is sampled on the rising edge of the clock.
TXDA,TXDB	O	Transmitter Serial Data Outputs. The least significant bit is transmitted first. Held in the marking (high) state when the transmitter is idle or disabled or when the channel operates in local loopback mode. If external transmitter clock is specified, the data is shifted out on the falling edge of the clock.

XR-88C681/68C681

Mnemonic	Type	Description
OP0	O	Output 0. Can be programmed as a general purpose output or as the channel A request-to-send output (RTSAN). Active low.
OP1	O	Output 1. Can be programmed as a general purpose output or as the channel B request-to-send output (RTSBN). Active low.
OP2	O	Output 2. Can be programmed as a general purpose output, the channel A transmitter 1x or 16x clock output, or the channel A receiver 1x clock output. Active low.
OP3	O	Output 3. Can be programmed as a general purpose output, the channel B transmitter 1x clock output, the channel B receiver 1x clock output, or as an open drain counter/timer ready output. Active low.
OP4	O	Output 4. Can be programmed as a general purpose output or as an open drain channel A RXRDY/FFULL output. Active low.
OP5	O	Output 5. Can be programmed as a general purpose output or as an open drain channel B RXRDY/FFULL output. Active low.
OP6	O	Output 6. Can be programmed as a general purpose output or as an open drain channel A TXRDY output. Active low.
OP7	O	Output 7. Can be programmed as a general purpose output or as an open drain channel B TXRDY output. Active low.
IP0	I	Input 0. General purpose input or CTSAN, the channel A active low clear-to-send input.
IP1	I	Input 1. General purpose input or CTSBN, the channel B active low clear-to-send input.
IP2	I	Input 2. General purpose input, counter/timer external clock input, or channel B receiver external clock input.
IP3	I	Input 3. General purpose input or channel A transmitter external clock input.
IP4	I	Input 4. General purpose input or channel A receiver external clock input.
IP5	I	Input 5. General purpose input or channel B transmitter external clock input.
V _{CC}	I	+5 Volt Power Input.
GND	I	Signal and Power Ground.

XR-88C681/68C681

PRINCIPLES OF OPERATION

As illustrated in the block diagram, the DUART consists of the following major blocks:

- Data Bus Buffer
- Operation Control
- Interrupt Control
- Timing Circuits
- Input Port
- Output Port
- Serial Channels A and B

Data Bus Buffer

The data bus buffer provides the interface between the internal and external data busses. It is controlled by the operation control block to allow data transfers to take place between the host CPU and the DUART.

Operation Control

The operation control logic receives operating commands from the CPU and generates signals to various sections of the DUART to appropriately control the device's operation. It contains address decoding and read and write circuits to permit communications with the microprocessor and registers to store configuration commands and device status.

The XR-68C681 version includes a data transfer acknowledge (DTACKN) output which is asserted during data transfer cycles to verify that the requested operation has been completed. It indicates that the

input data has been latched during a write cycle, that the requested data is on the data bus during a read cycle, or that the interrupt vector is on the data bus during an interrupt acknowledge cycle.

The addressing of the internal elements of the DUART is described in Table 1. Mode registers 1 and 2 of each channel are accessed via independent auxiliary pointers. The pointer is set to point to MR1x by a hardware reset or by invoking a 'reset pointer' command to the appropriate channel via its command register. Any read or write operation to the mode register while the pointer is pointing at MR1x switches the pointer to point to MR2x. The pointer then remains pointing to MR2x, so that subsequent accesses are always to MR2x unless the pointer is reset as described above.

Interrupt Control

An interrupt request output signal (INTRN) is provided which may be programmed to be asserted upon the occurrence of any of the following events:

- Transmit holding register A or B empty
- Receive holding register A or B ready
- Receive FIFO A or B full
- Start or end of received break, channel A or B
- Counter terminal Count reached
- Change of state on input pins IP0, IP1, IP2 or IP3

Associated with the interrupt system are the interrupt status register (ISR), the interrupt mask register (IMR),

Table 1. DUART Port and Register Addressing

A3	A2	A1	A0	Read	Write
0	0	0	0	Mode Register A (MR1A, MR2A)	Mode Register A (MR1A, MR2A)
0	0	0	1	Status Register A (SRA)	Clock Select Register A (CSRA)
0	0	1	0	Interrupt Status Register, Masked (ISR)	Command Register A (CRA)
0	0	1	1	Rx Holding Register A (RHRA)	Tx Holding Register A (THRA)
0	1	0	0	Input Port Change Register (IPCR)	Auxiliary Control Register (ACR)
0	1	0	1	Interrupt Status Register, Unmasked (ISR)	Interrupt Mask Register (IMR)
0	1	1	0	Counter/Timer Upper Byte (CTU)	Counter/Timer Upper Register (CTUR)
0	1	1	1	Counter/Timer Lower Byte (CTL)	Counter/Timer Lower Register (CTLR)
1	0	0	0	Mode Register B (MR1B, MR2B)	Mode Register B (MR1B, MR2B)
1	0	0	1	Status Register B (SRB)	Clock Select Register B (CSRB)
1	0	1	0	RESERVED	Command Register B (CRB)
1	0	1	1	Rx Holding Register B (RHRB)	Tx Holding Register B (THRB)
1	1	0	0	Interrupt Vector Register (IVR)	Interrupt Vector Register (IVR)
1	1	0	1	Input Port	Output Port Configuration Register (OPCR)
1	1	1	0	Start Counter Command	Set Output Port Bits Command
1	1	1	1	Stop Counter Command	Reset Output Port Bits Command

Note: In XR68C681 version, replace A3-A0 above with A4-A1 respectively.

and the interrupt vector register (IVR). The ISR indicates the current state of all the potential interrupting conditions listed above. The IMR may be programmed to select only certain of these conditions to assert the INTRN output. The ISR can be read by the CPU either masked or unmasked by the IMR. If read masked by the IMR, only the state of the conditions which have been programmed to cause an interrupt is output. If read unmasked, the state of all conditions, whether programmed to cause an interrupt or not, is output.

The XR-88C681/40 version may be programmed to operate in two modes to accommodate different CPU interface requirements. In the 'I-mode', which is the default mode after a hardware reset, interrupt prioritization and interrupt vector generation, if required, are implemented using external hardware. In this mode, the on-chip interrupt vector register is not utilized and is available for use as an auxiliary read/write register for any purpose.

In the 'Z' mode, which is invoked via a command to

command register B, pins 37, 38 and 39 are designated interrupt acknowledge input (IACKN), interrupt enable output (IEO) and interrupt enable input (IEI) respectively. IEI and IEO are the input and output of an interrupt daisy chain, as illustrated in Figure 1. IEI high means that the DUART may generate an interrupt request. A device with IEI high which is requesting an interrupt sets its IEO low to inhibit lower priority devices from generating their own interrupt requests. A device with its IEI low is inhibited from generating an interrupt and must also keep its IEO output low.

Sometime after the interrupt request is issued, the CPU will respond with an interrupt acknowledge cycle, asserting the IACKN and RDN inputs as shown in Figure 1. Assertion of IACKN must precede assertion of RDN. The time between the assertion of IACKN and the assertion of RDN allows the daisy chain to stabilize. The DUART is inhibited from issuing a new interrupt request while IACKN is asserted.

If the DUART is requesting an interrupt and its IEI is high when the leading edge of RDN is received, it is

3

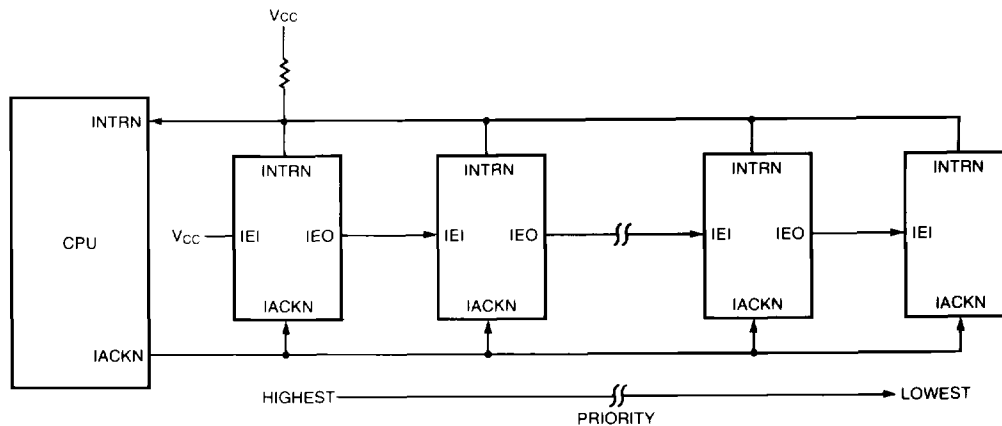

Figure 1A. Daisy chained Interrupt Block Diagram

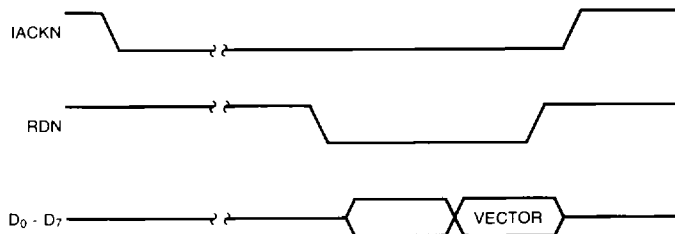

Figure 1B. Daisy chained Interrupt Timing

XR-88C681/68C681

the highest priority device making the request. It sets its internal 'interrupt under service' (IUS) latch, which keeps its IEO negated regardless of what happens to the interrupt request (which may be negated, for example, by the read of the RHR). It also places the vector from the IVR on the data bus. Keeping IEO low prevents lower priority devices in the daisy chain from requesting an interrupt until the higher priority interrupt has been serviced. Upon completing the service routine, the CPU must issue a 'reset IUS latch' command to the chip, which resets the latch and returns the daisy chain to its normal condition.

In the XR-68C681 version, if the DUART has its interrupt request active, it responds to assertion of its IACKN input by placing the vector from the IVR on the data bus and asserting DTACKN. Otherwise, it ignores IACKN.

In either version, outputs OP3-OP7 can be, programmed to provide separate open drain interrupt requests for transmitters A and B, receivers A and B, and the counter/ timer. See pin description.

Timing Circuits

The timing block contains a crystal oscillator, a bit rate generator (BRG), a programmable 16-bit counter/timer (C/T), and four clock selectors. A detailed block diagram of this section is shown in Figure 2.

Crystal Oscillator

The crystal oscillator operates from a crystal connected between the X1/CLK and X2 pins. A crystal frequency of 3.6864 MHz is required for generation of standard bit rates by the bit rate generator (see Table 5). If an external clock is available, it may be connected to X1/CLK, with X2 left open or connected to ground. The output of the oscillator is used by the BRG, the C/T and other internal circuits. This requires that a clock within the specified limits always be supplied to the DUART.

Bit Rate Generator

The BRG uses the crystal oscillator or external clock as an input and generates the clock for 23 commonly used data communications bit rates ranging from 50 to 115.2K bits per second. The actual clock frequencies output from the BRG are at 16 times these rates. The counter/timer can also be used as a programmable bit rate generator to produce a 16x clock for any bit rate not provided by the BRG. The four clock select multiplexers allow each receiver and transmitter to independently select its operating frequency as one of the outputs from the BRG, the output of the counter/timer, or an external clock. Table 4 defines the input pins for external clocking for the three version of the DUART.

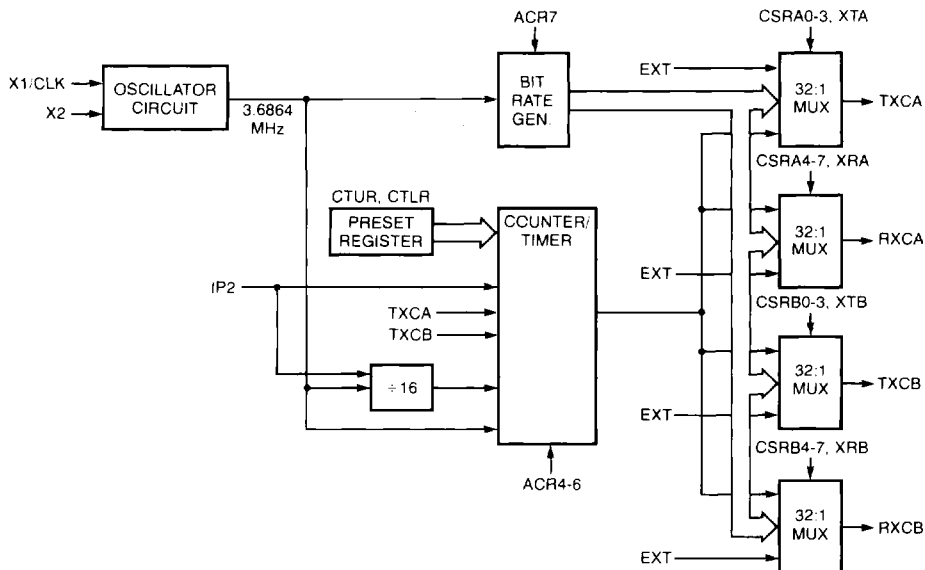

Figure 2. Timing Circuits Block Diagram

Counter/Timer

The C/T is a programmable 16-bit down-counter which can use one of several timing sources as its input. The CIT output is available to the clock selectors for use as a programmable bit rate for any receiver or transmitter, can be programmed to generate an interrupt each time it reaches its terminal count of OOOOH, and can also be programmed as an output at OP3.

In the timer mode, the C/T acts as a programmable divider and generates a square wave whose period is twice the value (in clock periods) of the contents of the counter/timer registers CTUR and CTLR. The contents of these registers may be changed at any time, but will only begin to take effect at the next half cycle of the square wave. The C/T begins operation using the values in CTUR/CTLR upon receipt of a 'startcounter' command (see Table 1). The C/T then runs continuously. A subsequent 'start counter' command causes the C/T to terminate the current timing cycle and to begin a new timing cycle using the current values in CTUR and CTLR. The counter ready status bit (ISR [3]) is set once each cycle of the square wave. This allows use of the C/T as a periodic interrupt generator if the condition is programmed to generate an interrupt via the interrupt mask register. The status bit can be reset by issuing a 'stop counter' command (see Table 1). In this mode, however, the command does not actually stop the C/T. The generated square wave is output on OP3 if it is programmed to be the C/T output.

In the counter mode, the C/T counts down the number of pulses written into CTUR/CTLR, beginning at the receipt of a 'start counter' command. The counter ready status bit (ISR[3]) is set upon reaching the count of OOOOH. The C/T will continue to count past this (with the next count being FFFFH) until it is stopped by the CPU via a 'stop counter' command. If OP3 is programmed to be the output of the C/T, the output remains high until the terminal count is reached, at which time the output goes low. OP3 returns to the high state and ISR [3] is cleared when the counter is stopped. A 'start counter' command while the counter is running restarts the counter with the values in CTUR/CTLR. The CPU may change CTUR or CTLR at any time but the new count takes effect only on the next start counter command. If new values are not programmed, the previous values are preserved and used for the next cycle.

In counter mode, the current value in the C/T may be read by the CPU by reading the upper and lower halves of the C/T separately (see Table 1),

stopping the counter when it is read is recommended in order to prevent potential problems which may occur if a carry from the lower half to the upper half occurs between the times that the two halves are read. However, note that a new start counter command will cause the counter to begin counting using the values in CTUR/CTLR.

Input Port

The current state of the inputs to this unlatched port can be read by the CPU by performing a read as described in Table 1. A high input results in a logic "1" while a low input results in a logic "0". The pin description tables describe the alternate uses for the input pins, such as clock inputs and interrupt control signals. A read of the input port will show the state at the pin, regardless of its programmed function. When the port is read, bit 7 will always read as a logic "1" in both versions of the DUART, and D6 will reflect the state of IACKN in the XR-68C681 version. Change of state detectors are provided for inputs IPO-IP3. These inputs are sampled by the 38.4 kHz, output of the BRG (2.4 Kbps x 16). A high-to-low or low-to-high transition at these input lasting at least two clock periods (approximately 50 μ s) will guarantee that the corresponding bit in the input port change register (IPCR) will be set, although it may be set by a change of state as short as 25 μ s. The status bits in the IPCR are cleared when the register is read by the CPU. Any change of state can also be programmed to generate an interrupt.

Output Port

The 8-bit output port can be used as a general purpose output port or can be used to output timing and status signals by appropriate programming of the mode registers (MR 1 A, MR2A, MR1B, MR2B) and with output port configuration register. When used to output status signals the pins are open drain, which allows their use in a wire-OR interrupt scheme.

When used as a general purpose output port, the outputs are the complements of the output port register (OPR). $OPR_{(n)} = 1$ results in $OP_{(n)}$ low while $OPR_{(n)} = 0$ results in $OP_{(n)}$ high. Bits of OPR can be set and reset individually. A bit is set by the address-triggered 'set output port bits' command (see Table 1) with the accompanying data specifying the bits to be set (1 = set, 0 = no change). A bit is reset by the address-triggered 'reset output port bits' command (see Table 1) with the accompanying data specifying the bits to be reset (1 = reset, 0 = no change).

XR-88C681/68C681

Serial Channels A and B

Each serial channel of the DUART comprises a full duplex asynchronous receiver and transmitter. The two channels can independently select their operating frequency (from the BRG, the C/T, or an external clock) as well as operating mode. Besides the normal mode in which the receiver and transmitter of each channel operate independently, the DUART can be configured to operate in various looping modes, which are useful for local and remote diagnostics, as well as in a wake-up mode used for multi-drop applications.

Note: In the descriptions which follow, the transmitter and receiver are described for either channel. References to in-put and output pins and control and status bits and registers apply to either channel unless otherwise noted.

Transmitter

The transmitter accepts parallel data from the CPU and converts it to a serial bit stream at the TXD pin, adding start, stop and optional parity bits as required by the asynchronous protocol.

The DUART is conditioned to transmit data when the transmitter is enabled via the command register. It indicates that it is ready to accept a character from the CPU for serialization by setting the TXRDY bit in the status register. This condition can be programmed to assert an interrupted request via the INTRN output and can also be programmed to assert the OP6 output (channel A) or the OP7 output (channel B). These conditions are negated when the CPU loads a character into the transmit holding register (THR). Data is transferred from the THR to the transmit shift register (TSR) immediately if the TSR is idle, or when it completes serialization of the previous character. The TXRDY condition is then asserted again. Thus, one full character time of buffering is provided. Note that the THR will not accept characters while the transmitter is disabled.

The transmitter sends a start bit followed by the programmed number of data bits (least significant bit first), an optional parity bit, and the programmed number of stop bits and then begins transmission of the next character if one has been loaded into the THR. Otherwise, the TXD output will remain high and the TXEMT status bit will be set following the transmission of the stop bits. Transmission resumes and the TXEMT status bit is cleared when the CPU loads a new character into the THR. The transmitter can be forced to send a continuous low at TXD by invoking a 'send break' command.

If the transmitter is disabled, it continues operating until the character currently being serialized, and any in the THR, are completely sent out. The transmitter can be reset by a software command. In this case, operation ceases immediately and the transmitter must be re-enabled before resuming operation.

Setting MR2[4] of the appropriate channel programs its transmitter to begin transmission of a character only if the channel's clear-to-send input pin (IPO for channel A, IP1 for channel B) is low. If CTSN goes high in the middle of a transmission, the transmission of the current character is completed but TXD remains high and the next character will not be sent until CTSN is low again. Setting MR2151 of the appropriate channel programs the transmitter to automatically deactivate its request-to-send output pin (OPO for channel A, OP1 for channel B). If so programmed, and the transmitter has been disabled, the RTSN output will be negated one bit time after the characters in the TS and THR (if any) are completely sent.

Receiver

The receiver accepts serial data at its RXD pin, checks for a proper start bit, converts the serial input to parallel form, checks the parity bit (if parity is specified), checks for presence of a stop bit, performs several other tests on the received data, and sends the assembled character to the CPU.

Each receiver is conditioned to receive data when it is enabled via the command register. It looks for a high to low (mark to space) transition indicating a start bit at the RXD input. If a transition is detected, the state of RXD is sampled each 16x clock for 7= clocks (16x clock mode) or at the next rising edge of the bit time clock (x clock). If RXD is detected high at these sample times, the start bit is invalid and the search for a start bit begins again. If RXD remains low, a valid start bit is assumed and the receiver continues to sample the data at one bit time intervals, at the theoretical center of the bit, until the programmed number of data bits (LSB first), the parity bit (if any), and one stop bit have been assembled. The data is then transferred to the receive holding register (RHR) with the most significant unused bits set to zero. The status conditions (parity error, framing error, overrun error, and break received) are set to indicate to the CPU that a character is available to be read. Setting of RXRDY can be programmed to generate an interrupt request via INTRN and to assert OP4 (channel A) or OP5 (channel B).

After the stop bit position is sampled, the receiver will immediately begin to look for the start bit of the next

character. However, if a non-zero character was received without a stop bit (framing error) and RXD remains low for half a bit time after sampling of the stop bit, the receiver operates as if a new start bit transition had been detected at that point (half a bit time after the sampling of the stop bit).

If a break is received (an all zeroes character including the first stop bit), only a single character consisting of all zeroes will be loaded into the FIFO and the break received status bit will be set, no matter how long the break condition persists. RXD must return to a high condition for at least half a bit time before the search for a new start bit begins again.

The RHR consists of a first-in-first-out (FIFO) stack with a capacity of three characters. Data is transferred from the receive shift register into the topmost empty position in the FIFO. RXRDY is set whenever one or more characters are in the FIFO, and the FFULL status bit is set if the FIFO is filled with data. Either of these bits can be selected to assert an interrupt. A read of the RHR outputs the data at the top of the FIFO and any remaining characters are pushed up, thus freeing a FIFO position for new data.

In addition to the data word, three status bits are appended to each character position in the FIFO. These are parity error, framing error, and received break. Status can be provided in two ways, as programmed by MR1[5] in the channel's mode register. In the 'character' mode status is provided on a character by character basis: the status applies only to the character at the top of the FIFO. In the block mode, these three bits in the status register are the cumulative logical-OR of the status for all characters coming to the top of the FIFO since the last 'reset error' command was issued. In either mode, reading the status register does not affect the FIFO. The FIFO is popped only when the RHR is read. Therefore, the status register should be read prior to reading the RHR. Also note that PE, FE and received break status bits are valid only when RXRDY in the status register is asserted.

If the FIFO is full when a new character is received, that character is held in the receive shift register until a FIFO position is available. If a new start bit is detected while this condition exists, the character previously in the shift register is lost and the overrun error status bit is set. The contents of the FIFO are not affected when this occurs.

If the receiver is disabled, the contents of the FIFO are maintained and can be read by the CPU. Resetting the

receiver initializes the FIFO pointers and clears the status bits immediately. In either case, any character currently being assembled is lost and operation does not resume until the receiver is re-enabled.

Setting MR[7] of the appropriate channel programs the receiver to automatically control de-activation of the request-to-send output (OP0 for channel A, OP1 for channel B). If so programmed, RTSN will be negated when a valid start bit is received while the FIFO is full, and will automatically be re-asserted when a FIFO position becomes available for that character. This feature can be used to prevent an overrun in the receiver by connecting the RTSN output to the CTSN input of the transmitting device.

Multidrop (8051 9-bit) Mode

Each serial channel of the DUART can be configured to operate in a wake-up mode useful for multidrop or multiprocessor applications. This mode is compatible with the serial 'Nine-bit Mode' of 8051-family microcomputers. In this mode of operation a master station, connected to a maximum of 256 slave stations, transmits an address character followed by a block of data characters targeted for the addressed slave station. The slave stations normally have their receivers disabled. However, in this mode, the slave receivers monitor the incoming data stream and wake up the CPU (by asserting RXRDY) when any address character is detected. The slave station CPU then compares the received address to its own assigned address and enables the receiver, if it wishes, to receive the subsequent block of data, or leaves the receiver disabled if it does not. Upon completion of reception of the block of data, the receiver is disabled to re-initiate the process.

The multidrop mode is selected by programming MR [4:3] of the channel to '11'. In this mode, a transmitted character consists of a start bit, the programmed number of data bits, an address/data flag bit (A/D), and the programmed number of stop bits. A/D = 0 indicates that the character is data, while A/D = 1 identifies it as an address. The CPU controls the state of A/D in the transmitted character by programming MR 1 [2] of the channel prior to loading the data bits into the THR. MR1[2] = 0 results in A/D = 0 and MR1[2] = 1 results in A/D = 1.

In the multidrop mode, the receiver continuously looks at RXD whether enabled or not. When disabled, it loads a character into the RHR and sets RXRDY if its A/D bit is one (address flag) but discards the character if its A/D bit is zero (data flag). If the receiver is

XR-88C681/68C681

enabled, all characters received are transferred to the RHR. In either case, the received data bits are loaded into the RHR while the A/D bit is loaded into SR[5], the status register position normally used for parity error. Framing error, overrun error, and break detect status bits operate normally.

Standby Mode

The DUART may be placed in a standby mode to conserve power when its operation is not required. Upon reset the DUART will be in the 'active operation' mode. A 'set stand-by mode' command issued via the channel A command register disables all clocks on the device except for the crystal oscillator, which significantly reduces the operating current. In this mode the only functions which will operate correctly are reading the input port, writing the output port and the 'Set active mode' command. The latter, also invoked via the channel A command register, restores the device to normal operation within 25 μ s. Resetting the transmitters and receivers and writing 00H into the interrupt mask register before going into the standby mode is recommended to prevent any spurious interrupts from being generated. The chip should be reprogrammed after the 'set active mode' command since register contents are not guaranteed to remain stable during the standby mode. Active operation can also be restored via hardware reset.

PROGRAMMING

Operation of the DUART is programmed by writing control words into the appropriate registers, while operational feed-back is provided by status registers which can be the CPU. Register addressing is shown in Table 1.

A hardware reset clears the contents of SRA, SRB, IMR, ISR, OPR and OPCR and initializes the IVR to OFH. During operation, care should be exercised if the contents of control registers are to be changed, since certain changes may result in improper operation. For example, changing the number of bits per character while data is being received may result in reception of an erroneous character. In general, changes to registers which control receiver or transmitter operation should be made only while the transmitter or receiver are disabled, and certain changes to the ACR should be made only when the C/T is stopped.

Mode, command, clock select, and status registers are duplicated for each channel to provide totally independent operation. Table 2 illustrates the bit assignments for each register.

Note: In the descriptions which follow, registers which are duplicated for each channel are described generically. References to input and output pins and control and status bits and registers apply to each channel unless otherwise noted.

MR1A, MR1B - Channel A/B Mode Register 1

MR1 for each channel is accessed when the channel's MR pointer points to MR1. The pointer is set to MR1 by RESET or by a 'set pointer' command invoked via the channel's command register. After reading or writing MR1, the pointer will point to MR2.

MR1[7] - Receiver Request-to-Send Control

This bit controls the negation of the RTSN output (OP0 for channel A, OP1 for channel B) by the receiver. RTSN is normally asserted by setting OP0 or OP1 for channels A and B respectively, and negated by resetting the same bit. MR1[7] = 1 causes RTSN to be negated automatically upon receipt of a valid start bit if the channel's FIFO is full and to be re-asserted again when an empty FIFO position becomes available. This flow control feature can be used to prevent overrun of the receiver by using the RTSN output to control transmission of characters to the DUART.

MR1[6] - Receiver Interrupt Select

This bit selects either the RXRDY status bit or the FFULL status bit of the channel to be used for CPU interrupts. It also causes the selected bit to be output on OP4 (channel A) or OP5 (channel B) if the pin is programmed as an interrupt output via the OPCR.

MR1[5] - Error Mode Select

This bit controls the operation of the three FIFOed status bits (PE, FE, received break) for the channel. In the character mode these status bits apply only to the character currently at the top of the FIFO. In the block mode these bits are the cumulative logical-OR of the status for all characters coming to the top of the FIFO since the last 'reset error' command for the channel was issued.

MR1[4:3] - Parity Mode Select

If 'with parity' or 'force parity' operation is programmed a parity bit is added to the transmitted characters and the receiver performs a parity check on received characters. See OPERATION section for description of multidrop mode operation.

Table 2. Register Bit Formats

	BIT7	BIT6	BIT5	BIT4	BIT3	BIT2	BIT1	BIT0
	Rx RTS Control	Rx Int Select	Error Mode	Parity Mode		Parity Type	Bits Per Char.	
MR1A MR1B	0 = no 1 = yes	0 = RXRDY 1 = FFULL	0 = char 1 = block	00 = With Parity 01 = Force Parity 10 = No Parity 11 = Multi-drop Mode		0 = even 1 = odd	00 = 5 01 = 6 10 = 7 11 = 8	

	BIT7	BIT6	BIT5	BIT4	BIT3	BIT2	BIT1	BIT0
	Channel Mode		Tx RTS Control	CTS Enable Tx	Stop Bit Length*			
MR2A MR2B	00 = Normal 01 = Auto Echo 10 = Local Loop 11 = Remote Loop		0 = no 1 = yes	0 = no 1 = yes	0 = 0.563 1 = 0.625 2 = 0.688 3 = 0.750	4 = 0.813 5 = 0.875 6 = 0.938 7 = 1.000	8 = 1.563 9 = 1.625 A = 1.688 B = 1.750	C = 1.813 D = 1.875 E = 1.938 F = 2.000

*Add 0.5 to values shown for 0-7 if channel is programmed for 5 bits/character.

	BIT7	BIT6	BIT5	BIT4	BIT3	BIT2	BIT1	BIT0
CSRA CSRB	Receiver Clock Select				Transmitter Clock Select			
	See Table 3				See Table 3			

	BIT7	BIT6	BIT5	BIT4	BIT3	BIT2	BIT1	BIT0
	Miscellaneous Commands				Disable Tx	Enable Tx	Disable Rx	Enable Rx
CRA CRB	See Text				0 = no 1 = yes	0 = no 1 = yes	0 = no 1 = yes	0 = no 1 = yes

	BIT7	BIT6	BIT5	BIT4	BIT3	BIT2	BIT1	BIT0
	Received Break	Framing Error	Parity Error	Overrun Error	TXEMT	TXRDY	FFULL	RXRDY
SRA SRB	0 = no 1 = yes *	0 = no 1 = yes *	0 = no 1 = yes *	0 = no 1 = yes	0 = no 1 = yes	0 = no 1 = yes	0 = no 1 = yes	0 = no 1 = yes

*These status bits are appended to the corresponding data character in the receive FIFO. A read of the status register provides these bits (7:5) from the top of the FIFO together with bits 4:0. These bits are cleared by a 'reset error status' command. In character mode they are discarded when the corresponding data character is read from the FIFO.

	BIT7	BIT6	BIT5	BIT4	BIT3	BIT2	BIT1	BIT0
	OP7	OP6	OP5	OP4	OP3		OP2	
OPCR	0 = OPR[7] 1 = TXRDYB	0 = OPR[6] 1 = TXRDYA	0 = OPR[5] 1 = RXRDY/ FFULLB	0 = OPR[4] 1 = RXRDY/ FFULLA	00 = OPR[3] 01 = C/T Output 10 = TxCB (1X) 11 = RxCB (1X)		00 = OPR[2] 01 = TXCA (16X) 10 = TXCA (1X) 11 = RXCA (1X)	

	BIT7	BIT6	BIT5	BIT4	BIT3	BIT2	BIT1	BIT0
	BRG Set Select	Counter/Timer Mode and Source			Delta IP3 Int	Delta IP2 Int	Delta IP1 Int	Delta IP0 Int
ACR	0 = Set1 1 = Set2	See Table 6			0 = Off 1 = On	0 = Off 1 = On	0 = Off 1 = On	0 = Off 1 = On

3

XR-88C681/68C681

Table 2. Register Bit Formats (continued)

	BIT7	BIT6	BIT5	BIT4	BIT3	BIT2	BIT1	BIT0
	Delta IP3	Delta IP2	Delta IP1	Delta IP0	IP3	IP2	IP1	IP0
IPCR	0 = No 1 = Yes	0 = No 1 = Yes	0 = No 1 = Yes	0 = No 1 = Yes	0 = Low 1 = High	0 = Low 1 = High	0 = Low 1 = High	0 = Low 1 = High

	BIT7	BIT6	BIT5	BIT4	BIT3	BIT2	BIT1	BIT0
	Input Port Change	Delta Break B	RXRDY/FFULLB	TXRDYB	Counter Ready	Delta Break A	RXRDY/FFULLA	TXRDYA
ISR	0 = No 1 = Yes	0 = No 1 = Yes	0 = No 1 = Yes	0 = No 1 = Yes	0 = No 1 = Yes	0 = No 1 = Yes	0 = No 1 = Yes	0 = No 1 = Yes

	BIT7	BIT6	BIT5	BIT4	BIT3	BIT2	BIT1	BIT0
	Input Port Change Int	Delta Break B Int	RXRDY/FFULLB Int	TXRDYB Int	Counter Ready Int	Delta Break A Int	RXRDY/FFULLA Int	TXRDYA Int
IMR	0 = Off 1 = On	0 = Off 1 = On	0 = Off 1 = On	0 = Off 1 = On	0 = Off 1 = On	0 = Off 1 = On	0 = Off 1 = On	0 = Off 1 = On

	BIT7	BIT6	BIT5	BIT4	BIT3	BIT2	BIT1	BIT0
CTU CTUR	C/T[15]	C/T[14]	C/T[13]	C/T[12]	C/T[11]	C/T[10]	C/T[9]	C/T[8]

	BIT7	BIT6	BIT5	BIT4	BIT3	BIT2	BIT1	BIT0
CTL CTLR	C/T[7]	C/T[6]	C/T[5]	C/T[4]	C/T[3]	C/T[2]	C/T[1]	C/T[0]

	BIT7	BIT6	BIT5	BIT4	BIT3	BIT2	BIT1	BIT0
IVR	IVR[7]	IVR[6]	IVR[5]	IVR[4]	IVR[3]	IVR[2]	IVR[1]	IVR[0]

MR1[2] - Parity Type Select

This bit selects odd or even parity if 'with parity' mode is programmed and the state of the forced parity bit if the 'force parity' mode is programmed. In the Multidrop mode it selects the state of the A/D flag bit. This bit has no effect if 'no parity' mode is programmed.

MR1[1:0] - Bits per Character Select

Selects the number of bits to be transmitted and received in the data field of the character. This does not include start, parity and stop bits.

MR2A, MR2B - Channel A/B Mode Register 2

MR2 for each channel is accessed when the channel's MR Pointer points to MR2, which occurs after any access to the channel's MR1. Reading or writing MR2 does not change the pointer.

MR2[7:6] - Channel Mode Select

Each channel can operate in one of four modes. MR2[7:6] = 00 in the normal mode where the receiver and transmitter operate independently.

MR2[7:6] = 01 places the channel in the automatic echo mode, which automatically retransmits the received data. The following conditions apply while in this mode:

1. Received data is transmitted on the channel's TXD output.
2. The receiver must be enabled but the transmitter not be enabled.
3. The channel's TXRDY and TXEMT status bits are inactive.

4. The received parity is checked but is not regenerated for transmission. Thus, transmitted parity is as received.
5. Character framing is checked but the stop bits are retransmitted as received.
6. A received break is echoed as received until the next valid start bit is detected.
7. CPU to receiver communications operate normally, but the CPU to transmitter link is disabled.

Two diagnostic modes can also be configured. The first is the local loopback mode, selected by MR2[7:6]
In this mode:

1. The transmitter output is internally connected to the receiver input.
2. The transmit clock is used for the receiver.
3. The Channel's TXD output is held marking (high).
4. The channel's RXD input is ignored.
5. The transmitter is enabled, but the receiver need not be enabled.
6. CPU to transmitter and receiver communications continue normally.

The second diagnostic mode is the remote loopback mode, selected by MR2[7:6] = 11. In this mode:

1. Received data is transmitted on the channel's TXD output.
2. Received data is not sent to the CPU and the error status conditions are not checked.
3. Parity and framing (stop bits) are transmitted as received.
4. The receiver must be enabled.
5. A received break is echoed as received until the next valid start bit is detected.

Care must be taken when switching into and out of the various modes. The selected mode will be activated immediately after it is programmed even if this occurs in the middle of transmitting or receiving a character. An exception to this is switching out of autoecho or remote loopback modes: if the de-selection occurs just after the receiver has sampled the stop bit (indicated in

autoecho by assertion of RXRDY), and the transmitter is enabled, the transmitter will remain in autoecho or remote loopback mode until one entire stop bit has been transmitted.

MR2[5] - Transmitter Request-to-Send Control

This bit controls the negation of the RTSN output (OP0 for channel A, OP1 for channel B) by the transmitter. RTSN is normally asserted by setting OP0 or OP1 for channels A and B respectively, and negated by resetting the same bit. MR2[5] = 1 causes OP0 (channel A) or OP1 (channel B) to be reset automatically one bit time after the characters in the channel's transmit shift register and THR, if any, are completely transmitted, including the programmed number of stop bit, if the transmitter has been disabled. This feature can be used to automatically negate RTSN at the conclusion of a message as follows:

1. Program auto-reset mode (MR2[5] = 1).
2. Enable transmitter and assert the channel's RTSN output by setting the appropriate bit in the output port register.
3. Send message.
4. Disable the transmitter after the last character of the message is loaded into the THR.

MR2[4] - Clear-to-Send Control

If this bit is a 0, the channel's CTSN input (IP0 for channel A, IP1 for channel B) has no effect on the transmitter. If the bit is a 1, the transmitter checks the state of its CTSN each time it is ready to send a character. If CTSN is low, the character is transmitted. If CTSN is high, TXD remains in the marking state, and the transmission of the next character is delayed until CTSN goes low. Changes in CTSN while a character is being serialized do not affect transmission of that character.

MR2[3:0] -Stop Bit Length

This field programs the duration of the stop bit appended to each transmitted character. Stop bit durations of 9/16 to 1 bit time a 1-9/16 to 2 bit times, in increments of 1/16 bit, can be programmed for character lengths of 6, 7 and 8 bits. For a 5-bit character, the stop bit duration can be programmed from 1-1/16 to 2 bit times.

If an external 1x clock is programmed for the transmitter MR2(3) = 0 selects a stop bit duration of

XR-88C681/68C681

one bit time and MR2[3] = 1 selects a duration of two bit times for transmission.

The receiver only checks for a mark condition at the center of the first stop bit (that is, one bit time after the last data or parity bit is sampled) regardless of the programmed transmitted stop bit length.

CSRA, CSRB - Channel A/B Clock Select Register

CSR[7:4] and CSR[3:0] of each channel operate in conjunction with ACR[7] and the channel's 'set/clear BRG select extend' command's to allow independent selection of the bit rates for the receiver and transmitter respectively. The BRG can generate 23 different bit rates, of which 22 are available simultaneously. The set of 22 is selected by programming ACR [7]. The bit rates generated when using a 3.6864 MHz crystal or an external clock of the same frequency are shown in Table 3, where 'X' refers to the current state of the extend bit. Note that the actual outputs from the BRG are at 16x the bit rates shown in the table. See Table 4 for the source of EXT (external clock) for the three DUART versions.

CRA, CRB - Channel A/B Command Register

Each channel of the DUART has a command register used to supply commands to the respective channel. Multiple commands may be invoked simultaneously by a single write to the command register as long as the commands are non-conflicting.

CR[7:4] - Miscellaneous Commands

The encoded value of this field specifies a single command as follows:

0 0 0 0 - Null Command.

0 0 0 1 - Reset MR Pointer - causes the channel's MR pointer to point to MR1.

0 0 1 0 - Reset Receiver - resets the receiver as if a hardware reset had been applied. The receiver is disabled and the FIFO is flushed.

0 0 1 1 - Reset Transmitter - resets the transmitter as if a hardware reset had been applied. The TXD output is forced to a high level.

Table 3. CSR [3:0] Bit Rate Selection

Field CSR[7:4] CSR[3:0]				Bit Rate			
				ACR[7] = 0		ACR[7] = 1	
				X = 0	X = 1	X = 0	X = 1
0	0	0	0	50	75	75	50
0	0	0	1	110	110	110	110
0	0	1	0	134.5	134.5	134.5	134.5
0	0	1	1	200	150	150	200
0	1	0	0	300	3600	300	3600
0	1	0	1	600	14.4K	600	14.4K
0	1	1	0	1200	28.8K	1200	28.8K
0	1	1	1	1050	57.6K	2000	57.6K
1	0	0	0	2400	115.2K	2400	115.2K
1	0	0	1	4800	4800	4800	4800
1	0	1	0	7200	1800	1800	7200
1	0	1	1	9600	9600	9600	9600
1	1	0	0	38.4K	19.2K	19.2K	38.4K
1	1	0	1	Timer	Timer	Timer	Timer
1	1	1	0	EXT - 16x	EXT - 16x	EXT - 16x	EXT - 16x
1	1	1	1	EXT - 1x	EXT - 1x	EXT - 1x	EXT - 1x

Table 4. External Clock Source Input Pin

Function	XR88C681/28	XR88C681/40 I-mode	XR88C681/40 Z-mode	XR68C681
Transmitter A	IP2	IP3	IP3	IP3
Transmitter B	IP2	IP5	IP2	IP5
Receiver A	IP2	IP4	IP3	IP4
Receiver B	IP2	IP6	IP2	IP2
Counter/Timer	IP2	IP2	IP2	IP2

XR-88C681/68C681

0 1 0 0 - Reset Error Status - clears the received break, parity error, framing error and overrun error status bits, SR [7:3]. Used in character mode to clear the OE status bit (although the RB, PE, and FE bits will also be cleared) and in block mode to clear all error status after a block of data has been received.

0 1 0 1 - Reset Break Change Interrupt - clears the channel's break change interrupt status bit.

0 1 1 0 - Start Break - forces the TXD output low. The transmitter must be enabled to start a break. If the transmitter is empty, the start of the break may be delayed up to two bit times. If the transmitter is active, the break begins when the transmission of that character in the THR is completed, viz., TXEMT must be true before the break will begin.

0 1 1 1 - Stop Break - the TXD line will go high within two bit times. TXD will remain high for one bit time before the next character, if any, is transmitted.

1 0 0 0 - Sat Rx BRG Select Extend Bit - sets the receiver BRG select extend bit for the channel to 1.

1 0 0 1 - Clear Rx BRG Select Extend Bit - clears the receiver BRG select extend bit for the channel to 0.

1 0 1 0 - Set Tx BRG Select Extend Bit - sets the transmitter BRG select extend bit for the channel to 1.

1 0 1 1 - Clear Tx BRG Select Extend Bit - clears the transmitter BRG select extend bit for the channel to 0.

1 1 0 0 - Set Standby Mode (A)/Reset IUS Latch (B)

When this command is invoked via the channel A command register, power is removed from the transmitters, receivers, counter/timer and additional circuits to place the DUART in the standby mode. Normal operation is restored by a hardware reset or by invoking the 'set active mode' command.

When this command is invoked via the channel B command register, and the DUART (XR-88C681 version) is operating in Z-mode, it causes the interrupt-under-service latch to be reset.

1 1 0 1 - Set Active Mode (A)/Set Z-mode (B).

When this command is invoked via the channel A command register the DUART is removed from the standby mode and resumes normal operation.

When this command is invoked via the channel B command register, the DUART is conditioned to

operate in the Z- mode. This applies only to the XR-88C681 version.

1 1 1 0 - Reserved - do not invoke during operation.

1 1 1 1 - Reserved - do not invoke during operation.

CR (3) - Disable Transmitter

This command terminates operation of the channel's transmitter and resets the TXRDY and TXEMT status bits. However, if a character is being transmitted or if a character is in the THR when the transmitter is disabled, the transmission of the character(s) is completed before going into the inactive state.

CR (2) - Enable Transmitter

This command enables operation of the channel's transmitter and asserts the TXRDY status bit.

CR [1] - Disable Receiver

This command immediately terminates operation of the channel's receiver. Any character being received will be, lost. The command has no effect on the receiver status bits or on any other control registers. If the multidrop mode is programmed, the receiver operates even if it is disabled. See OPERATION section.

CR [0] - Enable Receiver.

This command enables operation of the receiver. If not in the multidrop mode, it also forces the receiver to start searching for the start bit.

SRA, SRB - Channel A/B Status Register

SR [7] - Received Break

This bit indicates that an all zero character of the programmed length was received without a stop bit. Only a single FIFO position is occupied when a break is received. Additional transfers into the FIFO are inhibited until the RXD line returns to the marking state for at least half a bit time. This is defined as two successive edges of the internal or external 1 x clock.

When this bit is set, the channel's change in break status bit in the ISR is set. The bit in the ISR is also set when the end of the break condition, as defined above, is detected.

XR-88C681/68C681

SR [6] - Framing Error

When set, this bit indicates that RXD was low when the stop bit of the character is in the FIFO was sampled. The stop bit check is made in the middle of the first stop bit position (one bit time after sampling the last data bit or the parity bit at its midpoint) regardless of the stop bit length programmed.

SR [5] - Parity Error

This bit is set when the 'with parity' or 'force parity' modes are programmed if the corresponding character in the data FIFO was received with incorrect parity.

In the multidrop mode, this status bit indicates the state of received address/data (A/D) flag bit.

SR [4] - Overrun Error

If set, this bit indicates that one or more characters in

Table 5. Bit Rate Generator Characteristics
Crystal or Clock Input = 3.6864 MHz

Nominal Rate (bps)	Actual Clock (KHz)	Error (Percent)
50	0.8	0
75	1.2	0
110	1.759	-0.069
134.5	2.153	0.059
150	2.4	0
200	3.2	0
300	4.8	0
600	9.6	0
1050	16.756	-0.26
1200	19.2	0
1800	28.8	0
2000	32.056	0.175
2400	38.4	0
3600	57.6	0
4800	76.8	0
7200	115.2	0
9600	153.6	0
14.4K	230.4	0
19.2K	307.2	0
28.8K	460.8	0
38.4K	614.4	0
57.6K	921.6	0
115.2K	1843.2	0

Table 6 ACR [6:4] Field Definition

ACR[6:4]	Mode	Clock Source
0 0 0	Counter	External-IP2 Input
0 0 1	Counter	TXCA - 1x Clock of Channel A Tx
0 1 0	Counter	TXCB - 1x Clock of Channel B Tx
0 1 1	Counter	X1/CLK Input Divided by 16
1 0 0	Timer	External - IP2 Input
1 0 1	Timer	External Divided by 16 - IP2 Input
1 1 0	Timer	X1/CLK Input
1 1 1	Timer	X1/CLK Input Divided by 16

the received data stream have been lost. It is set upon receipt of a new character when the FIFO is full and a character is already in the receive shift register waiting for an empty FIFO position. When this occurs, the character in the receive shift register (and its error status) is overwritten.

This bit is cleared by a 'reset error status' command.

SR [3] - Transmitter Empty (TXEMT)

This bit is set when the transmitter underruns. It is set after transmission of the last stop bit of a character if there is no character in the THR awaiting transmission. It is reset when the THR is loaded by the CPU and when the transmitter is disabled.

SR [2] - Transmitter Ready (TXRDY)

This bit, when set, indicates that the THR is empty and ready to accept a character. The bit is cleared when the THR is loaded by the CPU and is set when that character is transferred to the transmit shift register. TXRDY is set when the transmitter is initially enabled and is reset when the transmitter is disabled. Characters loaded into the THR while the transmitter is disabled will not be transmitted.

SR [1] - FIFO Full (FFULL)

This bit is set when a character is transferred from the receive shift register to the FIFO and the transfer causes it to become full, i.e., all three FIFO positions are occupied. It is reset when the CPU reads the RHR. If a character is waiting in the shift register because the FIFO is full, FFULL will not be reset when the CPU reads the RHR.

SR [0] - Receiver Ready (RXRDY)

This bit indicates that a character has been received and is waiting in the FIFO to be ready by the CPU. It is set when a character is transferred from the receive shift register to the FIFO and reset when the CPU reads the last character currently stored in the FIFO.

OPCR - Output Port Configuration Register

This register programs the output port to provide alternate functions. Note that when an output is programmed as an interrupt, it is not masked by the contents of the IMR.

OPCR [7] - OP7 Output Select

This bit programs the OP7 output to provide one of the following:

- 0 - The complement of OPR [7]
- 1 - The channel B transmitter interrupt output, TXR-DYB, which is the complement of SRB [2]. In this mode, OP7 is an open drain output.

OPCR [6] - OP6 Output Select

This bit programs the OP6 output to provide one of the following:

- 0 - The complement of OPR [6].
- 1 - The channel A transmitter interrupt output, TXR-DYA, which is the complement of SRA[2]. In this mode OP6 is an open drain output.

OPCR [5] - OP5 Output Select

This bit programs the OP5 output to provide one of the following:

- 0 - The complement of OPR [5]
- 1 - The channel B receiver interrupt output which is the complement of ISR [5]. In this mode OP5 is an open drain output.

OPCR [4] - OP4 Output Select

This bit programs the OP4 output to provide one of the following:

- 0 - The complement of OPR [4].
- 1 - The channel A receiver interrupt output, which is the complement of ISR [1]. In this mode OP4 is an open drain output.

OPCR [3:2] - OP3 Output Select

These bits program the OP3 output to provide one of the following:

- 00 - The complement of OPR [3].
- 01 - The counter/timer output, in which case OP3 is an open drain output. In the timer mode the output is a square wave at the programmed frequency. In counter mode the output remains high until the

terminal count is reached, at which time it goes low. The output returns to the high state when the counter is stopped by a stop counter command.

- 10 - The 1x clock which shifts the output data for the channel B transmitter. A free running 1x clock is output if data is not being transmitted.
- 11 - The 1x clock which samples the input data for the channel B receiver. A free running 1x clock is output if data is not being received.

OPCR [1:0] - OP2 Output Select

These bits program the OP2 output to provide one of the following:

- 00 - The complement of OPR[2].
- 01 - The 16x clock selected for the channel A transmitter by CSRA [3:0]. This will be a 1x clock if external 1x clock is programmed.
- 10 - The 1x clock which shifts the output data for the channel A transmitter. A free running 1x clock is output if data is not being transmitted.
- 11 - The 1x clock which samples the input data for the channel A receiver. A free running 1x clock is output if data is not being received.

ACR - Auxillary Control Register

ACR [7] - Bit Rate Set Select

This bit selects one of two sets of bit rates to be generated by the BRG. The bit rates provided are selected by the channel A and B receiver and transmitter as described in the Clock Select Register description. Bit rate generator characteristics are shown in Table 5.

ACR [6:4] - Counter/Timer Mode and Clock Source Select

This field selects the operating mode and clock source for the counter/timer. See Table 6.

ACR [3:0] - Change of State Interrupt Enables

These bits select which bits of the input port cause the input port change bit in the interrupt status register (ISR [7]) to be set. If one of these bits is 'on', the setting of the corresponding bit in the IPCR by a change of state on the input will set ISR [7], and will also cause the

XR-88C681/68C681

interrupt request pin to be asserted if IMR [7] is set. However, if the bit is 'off', the setting of the corresponding bit in the IPCR has no effect on ISR [7].

IPCR - Input Port Change Register

IPCR [7:4] - IP3, IP2, IPI, IP0 Change of State

These bits are set when a change of state occurs at the respective input pins (see Input Port section). The bits are cleared when the CPU reads the IPCR.

The setting of these bits can be programmed to cause an interrupt to the CPU via ACR [3:0], ISR [7] and IMR [7].

IPCR [3:0] - IP3, IP2, IP1, IP0 Current State

These bits indicate the current state of the respective inputs at the time the IPCR is read.

ISR - Interrupt Status Register

This register provides the current status of all possible interrupt conditions. If a bit in the ISR is a '1' and the corresponding bit in the interrupt mask register (IMR) is also a '1' the interrupt request output will be asserted. If the corresponding bit in the IMR is a '0' the state of the bit in the ISR has no effect on the interrupt request output. The contents of this register can be read by the CPU either unmasked or masked by the IMR. See Table 1.XR-88C681/68C681

ISR [7] - Input Port Change Status

This bit is a '1' when a change of state has occurred at the IP0, IPI, IP2 or IP3 inputs and that event has been programmed to cause an interrupt via ACR [3:0]. It is cleared when the CPU reads the IPCR.

ISR [6] - Channel B Change In Break

This bit indicates that the channel B receiver has detected the beginning or end of a received break. It is reset when the CPU invokes a channel B 'reset break change interrupt' command.

ISR [5] - Channel B Receiver Ready or FIFO Full

The function of this bit is programmed by MR1B[6]. If programmed as receiver ready, it indicates that data is in the FIFO. It is set when a character is transferred from the receive shift register to the FIFO and cleared when the CPU reads the RHR. If there are still more characters in the FIFO after the read operation, the bit will be set again after the FIFO is 'popped.'

If this bit is programmed as FIFO full, it is set when a character is transferred from the receive shift register to the receive shift register to the FIFO if that transfer causes the FIFO to become full. It is reset when the CPU reads the RHR. If a character is waiting in the receive shift register because the FIFO is full, this bit will be set again after the read operation, when that character is loaded into the FIFO.

ISR [4] - Channel B Transmitter Ready

This bit is a duplicate of TXRDYB, SRB[2].

ISR [3] - Counter Ready

In the counter mode, this bit is set when the counter reaches terminal count and is reset when the counter is stopped by a 'stop counter' command.

In the timer mode, this bit is set once each cycle of the generated square wave. It is also set each time a 'start counter' command is issued if the output is, at that time, in the second (high) half of the square wave cycle. The bit is reset by a 'stop counter' command. The command, however, does not stop the C/T.

ISR [2] - Channel A Change in Break

This bit indicates that the channel A receiver has detected the beginning or end of a received break. It is reset when the CPU invokes a channel A 'reset break change interrupt' command.

ISR [1] - Channel A Receiver Ready or FIFO Full

The function of this bit is programmed by MR1A[6]. If programmed as receiver ready, it indicates that data is in the FIFO. It is set when a character is transferred from the receive shift register to the FIFO and cleared when the CPU reads the RHR. If there are still more characters in the FIFO after the read operation, the bit will be set again after the FIFO is 'popped.'

If this bit is programmed as FIFO full, it is set when a character is transferred from the receive shift register to the FIFO if that transfer causes the FIFO to become full. It is reset when the CPU reads the RHR. If a character is waiting in the receive shift register because the FIFO is full, this bit will be set again after the read operation, when that character is loaded into the FIFO.

ISR(0) - Channel A Transmitter Ready

The bit is duplicated of TXRDYA, SRA(2).

IMR - Interrupt Mask Register

This register selects which bits in the ISR cause an interrupt to be asserted. If a bit in the ISR is a '1' and the corresponding bit in the IMR is also a '1', the interrupt request output will be asserted. If the corresponding bit in the IMR is a '0', the state of the bit in the ISR has no effect on the interrupt request output. Note that the IMR does not mask the programmable interrupt outputs, OP3-OP7.

CTUR/CTLR - Counter/Timer Registers

The CTUR and CTLR hold the eight MSBs and eight LSBs respectively of the value to be used the the counter/timer in both of its modes of operation. The minimum value which may be loaded into CTUR/CTLR is 0001H. These registers are write-only and cannot be read by the CPU.

IVR-Interrupt Vector Register

The IVR holds the value which the DUART places on the data bus in response to assertion of the interrupt acknowledge input. This applies to the XR-68C681 and to the XR- 88C681 when operating in Z-mode. The register is not used for any function when the XR-88C681 operates in I-mode but remains writeable and readable by the CPU, and can be used for any purpose. The contents of this register are initialized to 9FH by a hardware reset.

XR-88C681/68C681

NOTES:

1. Stresses above those listed under the Absolute Maximum Ratings may cause permanent damage to the device. This is a stress rating only, and functional operation of the device at these or any other conditions above those indicated in the Electrical Characteristics section of this specification is not implied. Exposure to absolute maximum rating conditions for extended periods may affect device reliability.
2. This product includes circuitry specifically designed for the protection of its internal devices from damaging effects of excessive static charge. Nonetheless, it is suggested that conventional precautions be taken to avoid applying any voltage large, than the rated maxima.
3. Parameters are valid over the specified temperature and operating supply ranges. Typical values are at 25°C, VCC = 5V and typical processing parameters.
4. All voltages are referenced to ground (GND). For testing, input signal levels are 0.4V and 2.4V with a transition time of 20ns maximum. All time measurements are referenced at input voltages of 0.8V and 2.0V as appropriate. See Figure 3.
5. Measured operating with a 3.6864MHz crystal and with all outputs open.
6. AC test condition for outputs: CL = 150pF, except interrupt outputs: CL = 50pF, RL = 2.7K ohm to VCC.
7. For the XR88C681, timing is illustrated and referenced to the RDN and WRN inputs. The device may also be operated using CEN as the 'strobing' input. In this case, all specifications apply referenced to the falling and rising edges of CEN.
8. If CEN is used as the strobing input, this parameter defines the minimum high time between CENs.
9. Consecutive write operations to the same register require at least three edges of the X1 clock between writes.
10. This parameter is system dependent. For any DUART in the daisy chain, tIAS must be greater than the sum of EOD for the highest priority device in the daisy chain, tEIS for the DUART, and tDIO for each device separating them in the daisy chain.
11. This specification imposes a 6MHz maximum 68000 clock frequency if a read or write cycle follows immediately after the previous read or write cycle. A higher 68000 clock can be used if this is not the case.
12. This specification imposes a lower bound on CSN and IACKN low, guaranteeing that they will be low for at least one CLK period.
13. This parameter is specified only to insure that DTACKN is asserted with respect to the rising edge of X1/CLK as shown in the timing diagram, not to guarantee operation of the part. If the specified setup time is violated, DTACKN may be asserted as shown or may be asserted one clock cycle later.
14. The minimum high time must be at least 1.5 times the X1/CLK period and the minimum low time must be at least equal to the X1/CLK period if either channel's RX is operating in external 1 x clock mode.
15. For prime grade N, P, J, L, M, ML, VCC = 5 V ± 10%.

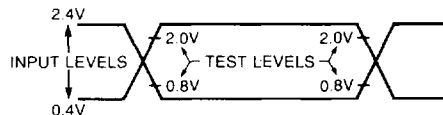

AC testing inputs are driven at 0.4V for a logic '0' and 2.4V for a logic '1' except for -40 to 85°C and -55 to 125°C, logic '1' shall be 2.6V. Timing measurements are made at 0.8V for a logic '0' and 2.0V for a logic '1'.

Figure 3. Input and Output Levels for Timing Measurements

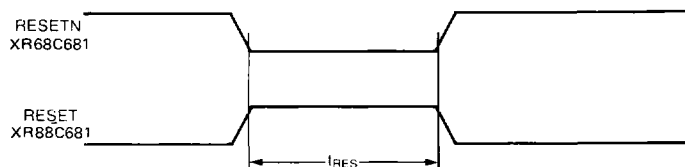

Figure 4. Reset Timing

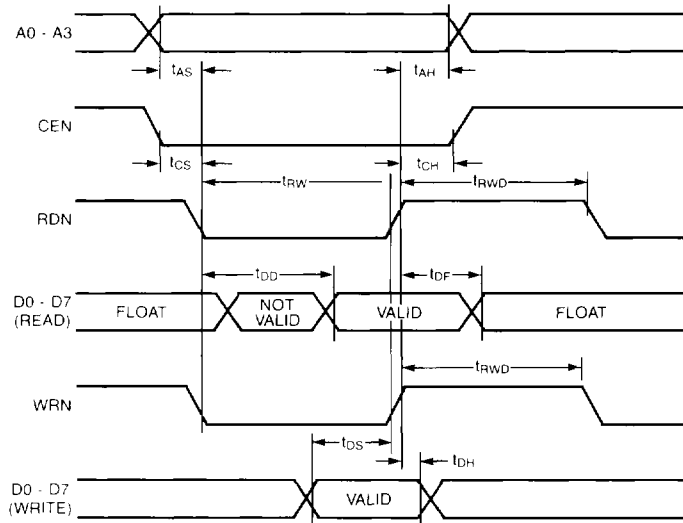

Figure 5. XR-88C681 Read and Write Cycle Timing

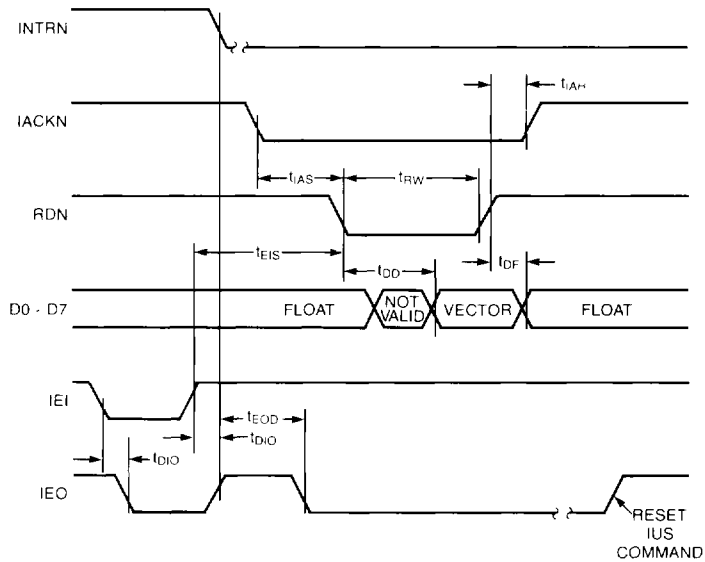

Figure 6. XR-88C681 Z-mode Interrupt Cycle Timing

XR-88C681/68C681

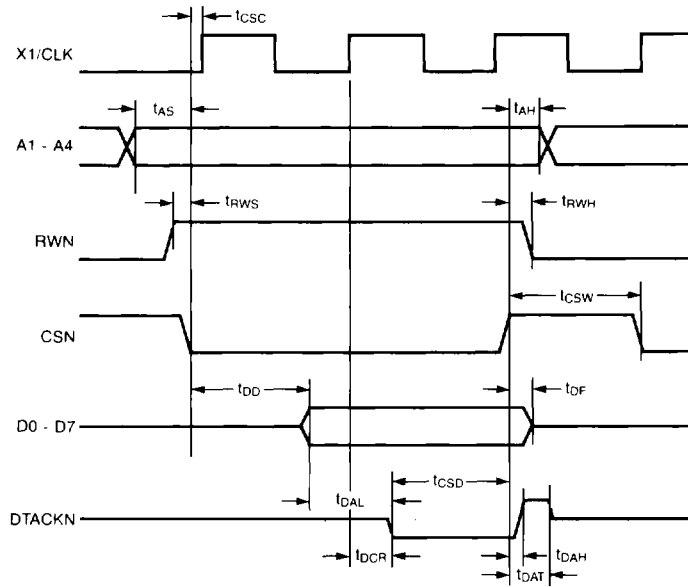

Figure 7. XR-68C681 Read Cycle Timing

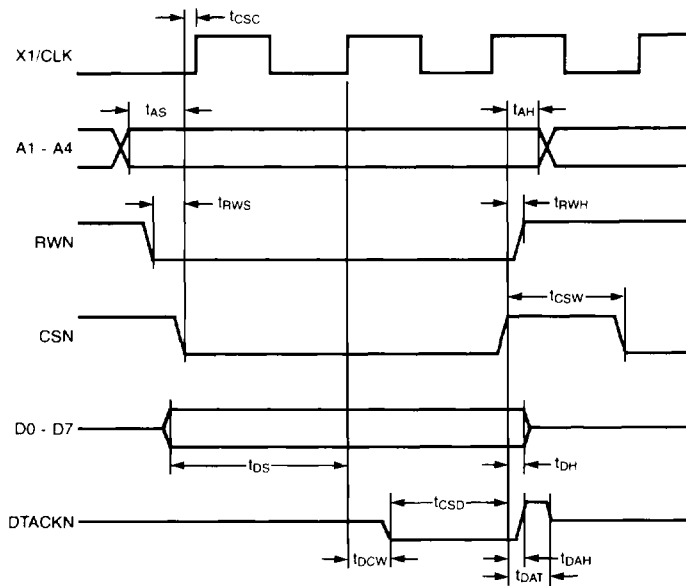

Figure 8. XR-68C681 Write Cycle Timing

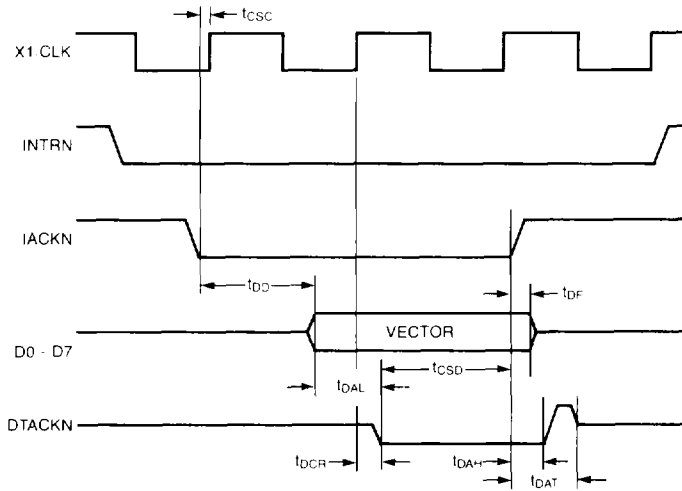

Figure 9. XR-68C681 Interrupt Cycle Timing

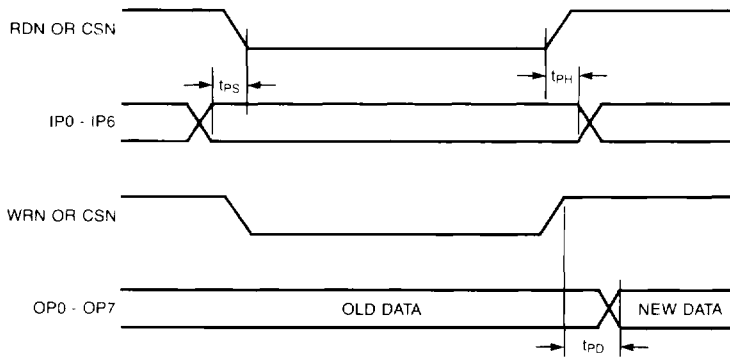
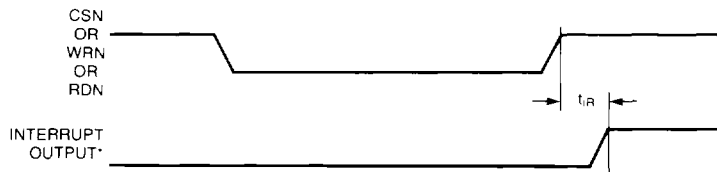

Figure 10. Port Timing



*INTRN or OP3 - OP7 when used as interrupt outputs.

Figure 11. Interrupt Timing

XR-88C681/68C681

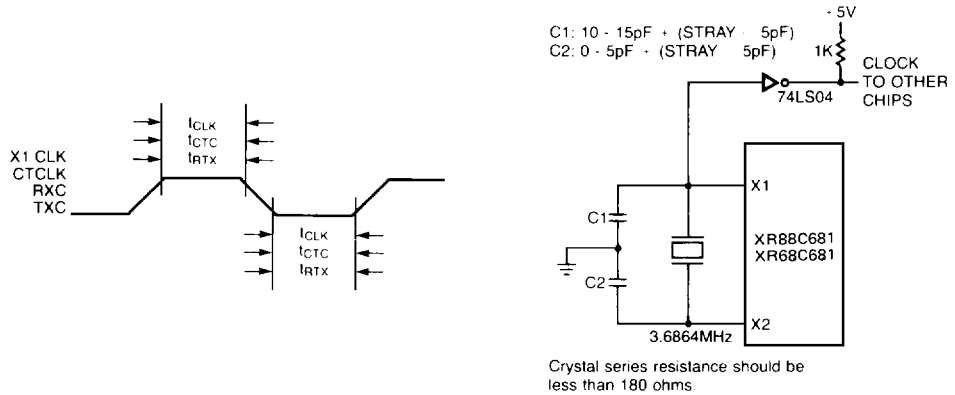

Figure 12. Clock Timing

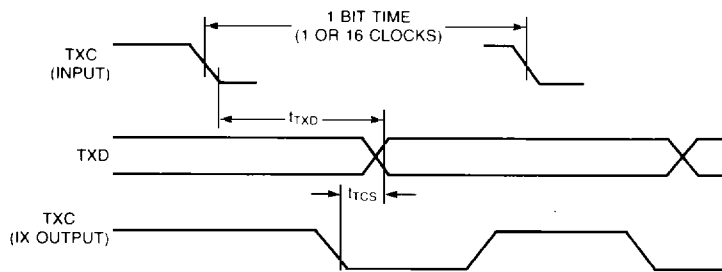

Figure 13. Transmitter Timing

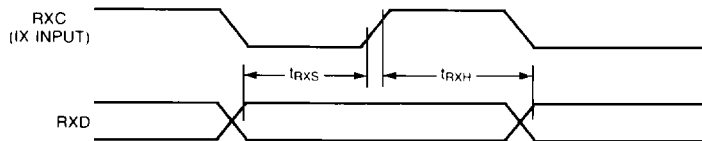
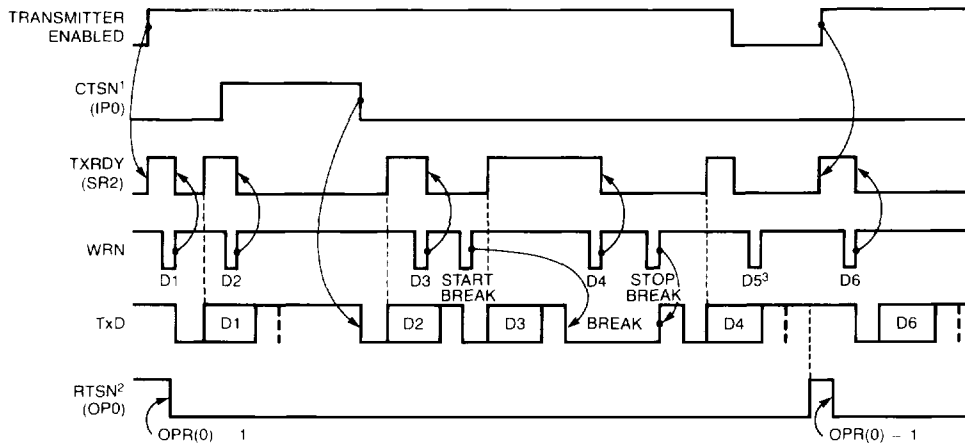

Figure 14. Receiver Timing



NOTES

1. Operation shown for MR2(4) = 1
2. Operation shown for MR2(5) = 1
3. D5 will not be transmitted

Figure 15. Transmitter Operation

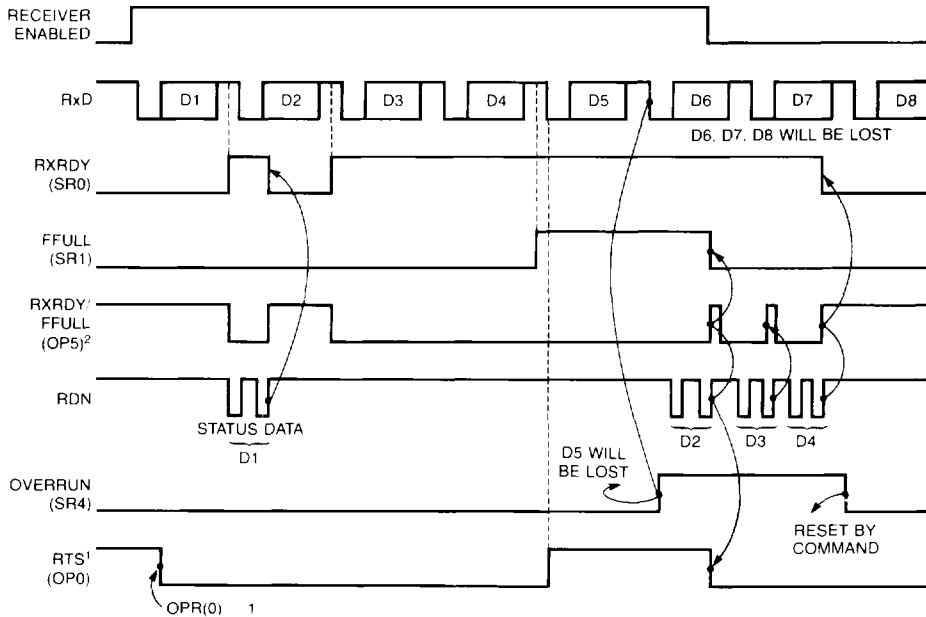

NOTES

1. Operation shown for MR1(7) = 1
2. Shown for OPCR(4) = 1 and MR1(6) = 0

Figure 16. Receiver Operation

XR-88C681/68C681

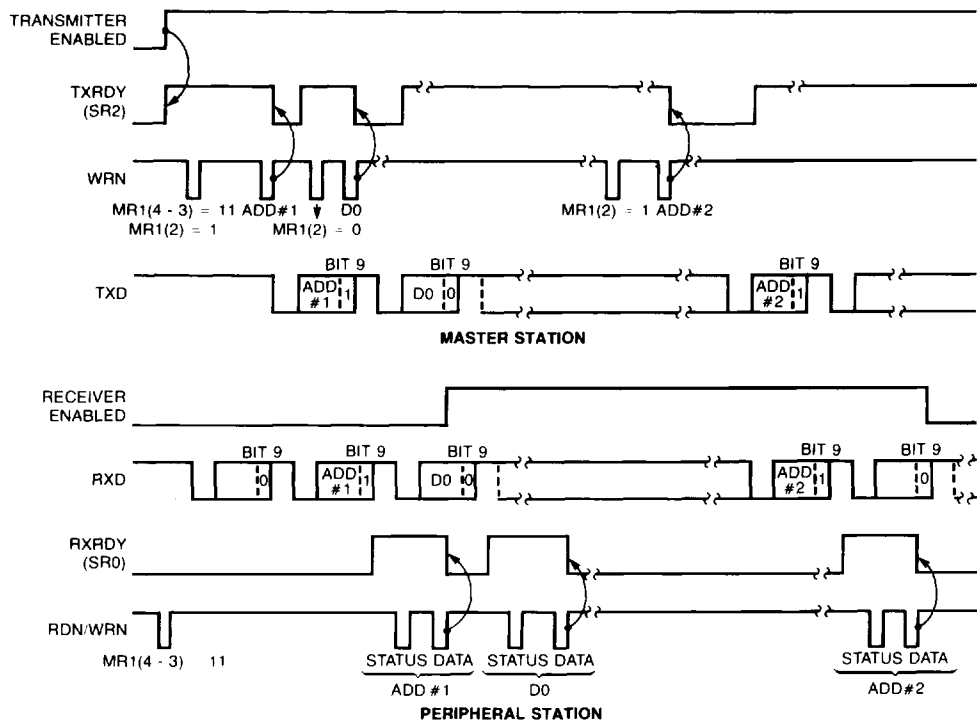
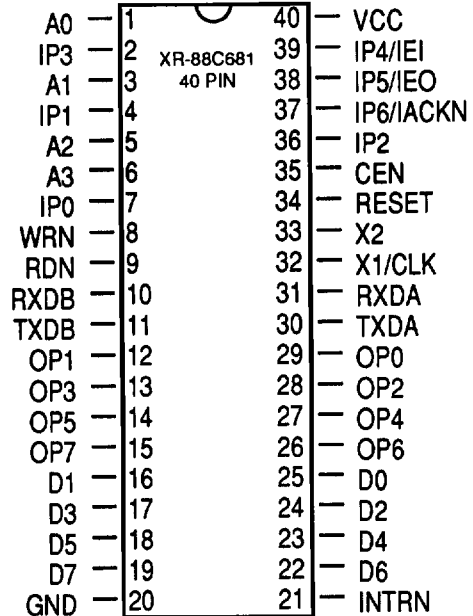
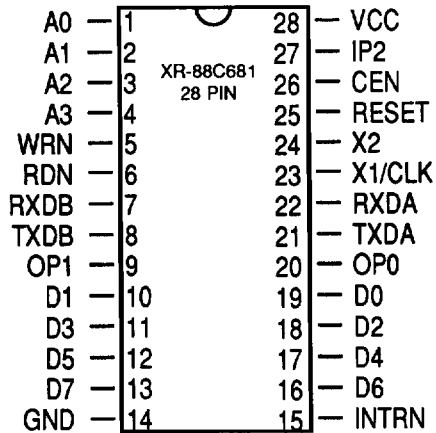
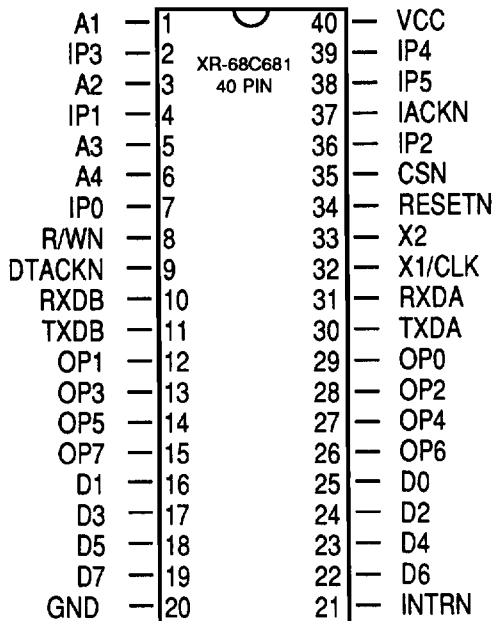

Figure 17. Transmitter and Receiver Operation in Multidrop Mode

XR-88C681/68C681



3



XR-88C681/68C681

