

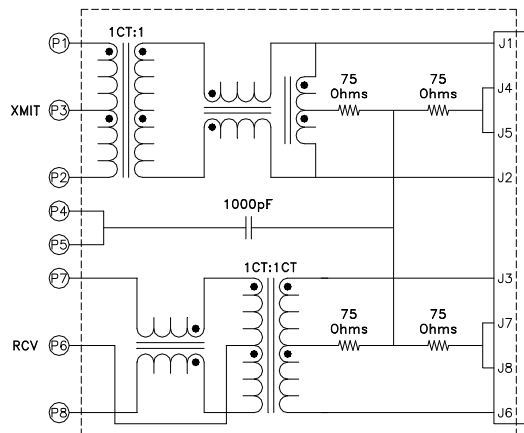

**Integrated 10/100 Base-T RJ45  
Surface Mount MIC25 Series**

**Midcom**

LANDatacom



**Features**

- Surface Mount
- Operating Temperature 0°C to 70°C
- Optional pin-outs
- Industry standard connector footprint
- Optimum performance
- Cost Effective

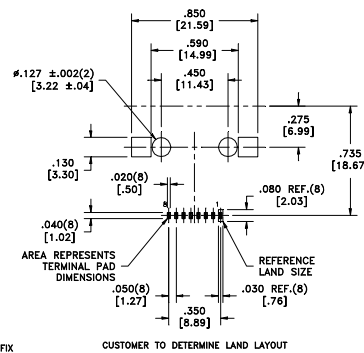
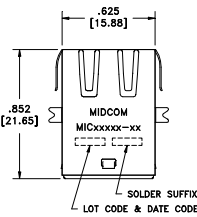
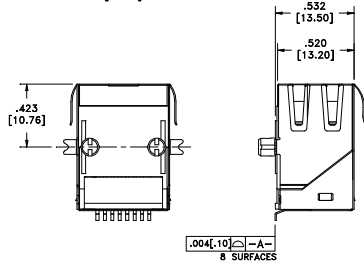
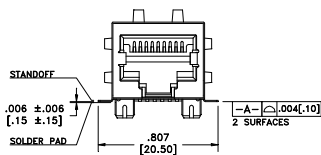

Part Number	LED (left-right)	Tab Direction	EMI Tabs
MIC25020-5110	None	Down	Yes

**Electrical Characteristics**

Inductance	350uH Min.	0.1Vrms, 100kHz, 8mA DC
Dielectric Rating	1500VAC	for 1 minute
Turns Ratio	1CT:1CT	±2%
Insertion Loss	-1.0dB max.	1MHz-100MHz
Return Loss	-18dB min.	1MHz-30MHz
	-16dB min.	30MHz-45MHz
	-14dB min.	45MHz-60MHz
	-12dB min.	60MHz-80MHz
Cross Talk	-35dB min.	1MHz-100MHz
Common Mode Rejection	-35dB min.	1MHz-100MHz