



CYPRESS

PRELIMINARY

CY7C1440V33

CY7C1442V33

CY7C1446V33

1M x 36/2M x 18/512K x 72 Pipelined SRAM

Features

- Fast clock speed: 250, 200, and 167 MHz
- Provide high-performance 3-1-1-1 access rate
- Fast access time: 2.7, 3.0 and 3.5 ns
- Optimal for depth expansion
- Single 3.3V -5% and +5% power supply V_{DD}
- Separate V_{DDQ} for 3.3V or 2.5V
- Common data inputs and data outputs
- Byte Write Enable and Global Write control
- Chip enable for address pipeline
- Address, data, and control registers
- Internally self-timed Write Cycle
- Burst control pins (interleaved or linear burst sequence)
- Automatic power-down for portable applications
- High-density, high-speed packages
- JTAG boundary scan for BGA packaging version
- Available in 119-ball bump BG, 165-ball FBGA package, and 100-pin TQFP packages (CY7C1440V33 and CY7C1442V33). 209 FBGA package for CY7C1446V33.

Functional Description

The Cypress Synchronous Burst SRAM family employs high-speed, low-power CMOS designs using advanced single-layer polysilicon, triple-layer metal technology. Each memory cell consists of six transistors.

The CY7C1440V33, CY7C1442V33, and CY7C1446V33 SRAMs integrate 1,048,576 x 36/2,097,152 x 18 and 524,288 x 72 SRAM cells with advanced synchronous peripheral circuitry and a two-bit counter for internal burst operation. All synchronous inputs are gated by registers controlled by a positive-edge-triggered Clock Input (CLK). The synchronous inputs include all addresses, all data inputs, address-pipelining

Chip Enable (\overline{CE}), burst control inputs (\overline{ADSC} , \overline{ADSP} , and \overline{ADV}), write enables (\overline{BWA} , \overline{BWB} , \overline{BWC} , \overline{BWD} , and \overline{BWE}), and Global Write (\overline{GW}).

Asynchronous inputs include the Output Enable (\overline{OE}) and burst mode control (MODE). The data ($DQ_{a,b,c,d}$) and the data parity ($DP_{a,b,c,d}$) outputs, enabled by \overline{OE} , are also asynchronous.

$DQ_{a,b,c,d}$ and $DP_{a,b,c,d}$ apply to CY7C1440V33, $DQ_{a,b}$ and $DP_{a,b}$ apply to CY7C1442V33, and $DQ_{a,b,c,d,e,f,g,h}$ and $DP_{a,b,c,d,e,f,g,h}$ apply to CY7C1446V33. a,b,c,d,e,f,g,h each are eight bits wide in the case of DQ and one bit wide in the case of DP.

Addresses and chip enables are registered with either Address Status Processor (ADSP) or Address Status Controller (ADSC) input pins. Subsequent burst addresses can be internally generated as controlled by the Burst Advance Pin (\overline{ADV}).

Address, data inputs, and write controls are registered on-chip to initiate self-timed WRITE cycle. WRITE cycles can be one to eight bytes wide as controlled by the write control inputs. Individual byte write allows individual byte to be written. \overline{BWA} controls DQ_a and DP_a . \overline{BWB} controls DQ_b and DP_b . \overline{BWC} controls DQ_c and DP_c . \overline{BWD} controls DQ_d and DP_d . \overline{BWE} controls DQ_e and DP_e . \overline{BWF} controls DQ_f and DP_f . \overline{BWG} controls DQ_g and DP_g . \overline{BWH} controls DQ_h and DP_h . \overline{BWA} , \overline{BWB} , \overline{BWC} , \overline{BWD} , \overline{BWE} , \overline{BWF} , \overline{BWG} , and \overline{BWH} can be active only with \overline{BWE} LOW. \overline{GW} LOW causes all bytes to be written. Write pass-through capability allows written data available at the output for the immediately next Read cycle. This device also incorporates pipelined enable circuit for easy depth expansion without penalizing system performance.

All inputs and outputs of the CY7C1440V33, CY7C1442V33, and the CY7C1446V33 are JEDEC-standard JESD8-5-compatible.

Selection Guide^[1]

		CY7C1440V33 CY7C1446V33 CY7C1446V33 -300	CY7C1440V33 CY7C1446V33 CY7C1446V33 -250	CY7C1440V33 CY7C1446V33 CY7C1446V33 -200	CY7C1440V33 CY7C1446V33 CY7C1446V33 -167	Unit
Maximum Access Time		2.3	2.7	3.0	3.5	ns
Maximum Operating Current	Com'l	TBD	TBD	TBD	TBD	mA
Maximum CMOS Standby Current		TBD	TBD	TBD	TBD	mA

Note:

1. Shaded areas contain advance information.

Logic Block Diagram CY7C1440V33-1M x 36

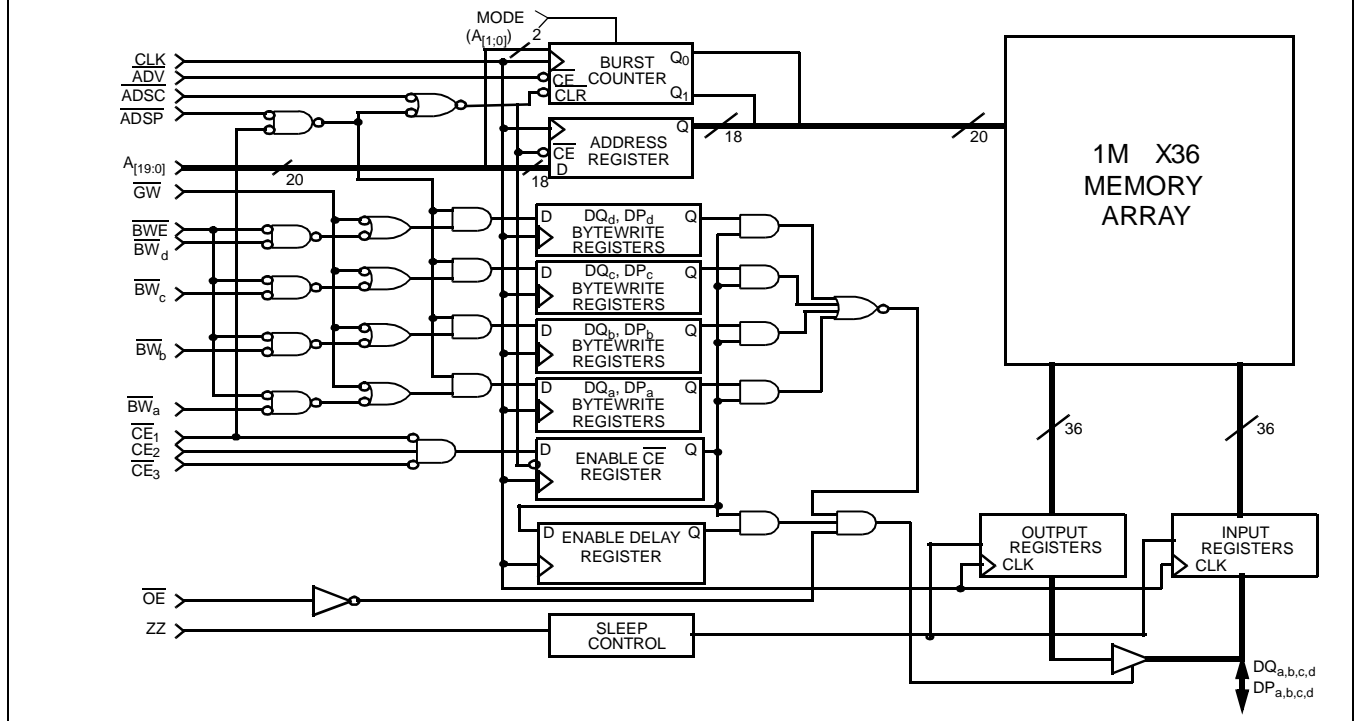

CY7C1446V33-2M x 18

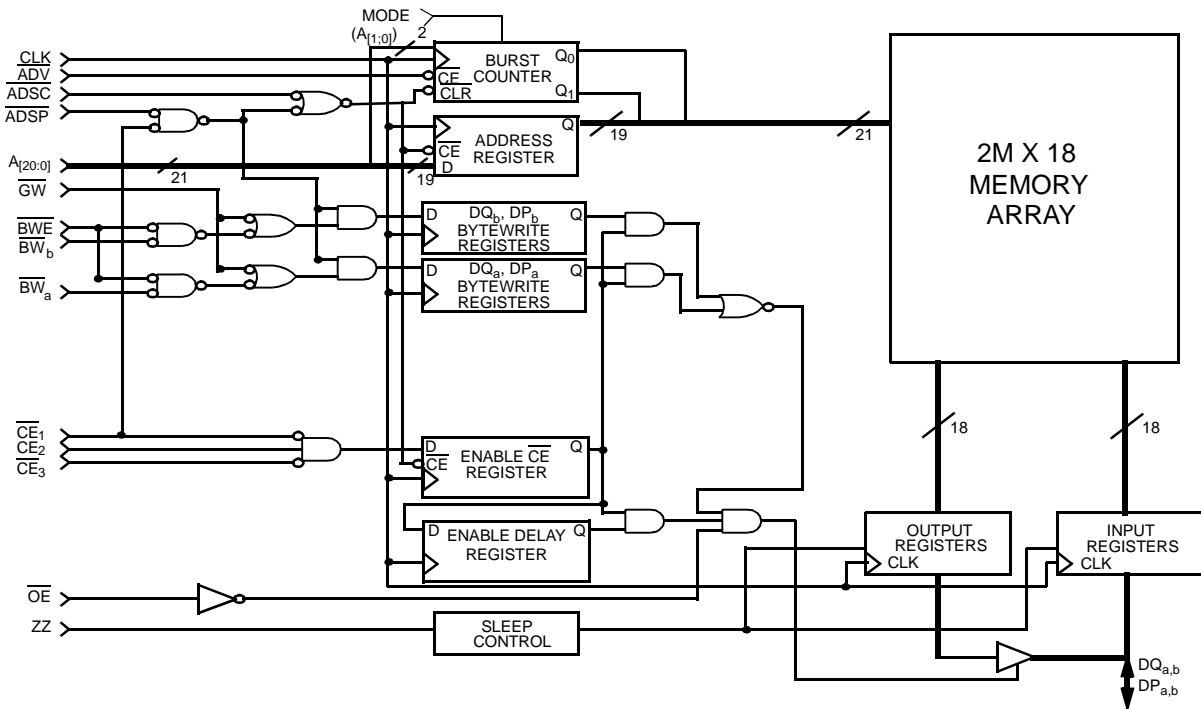

CY7C1446V33 – 512K x 72

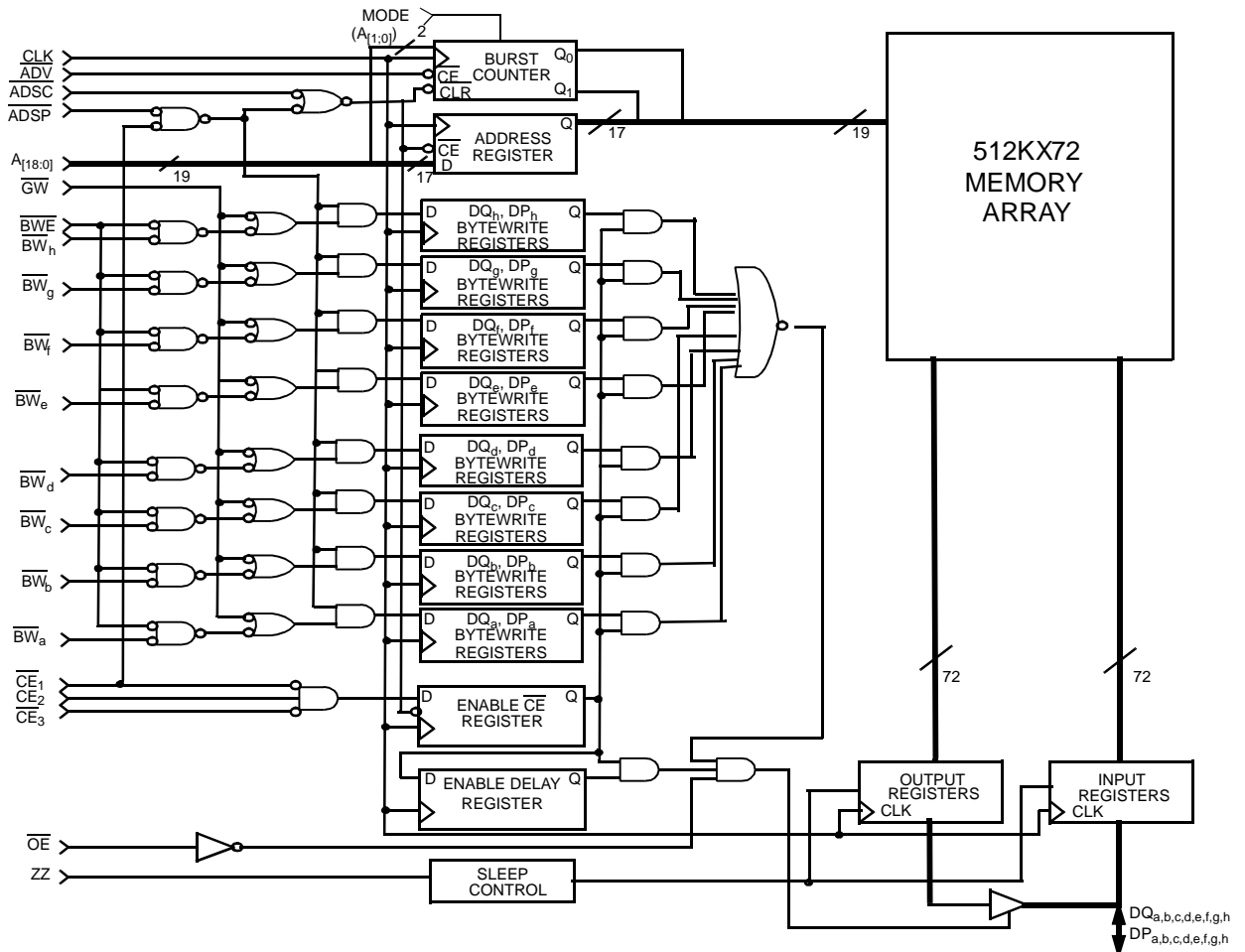



PRELIMINARY

CY7C1440V33
CY7C1442V33
CY7C1446V33

Pin Configurations

100-pin TQFP

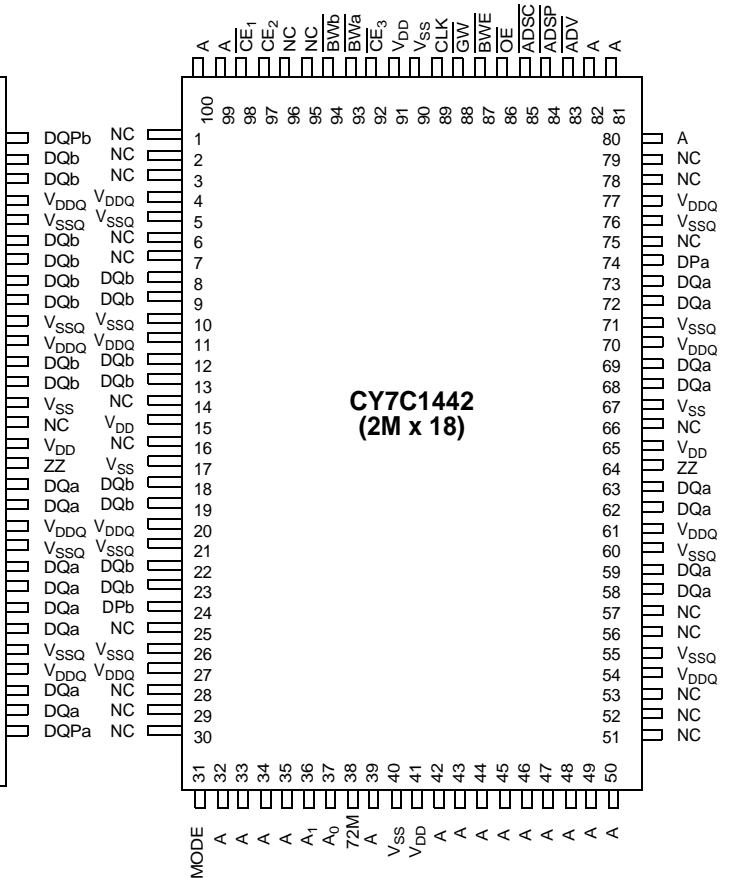
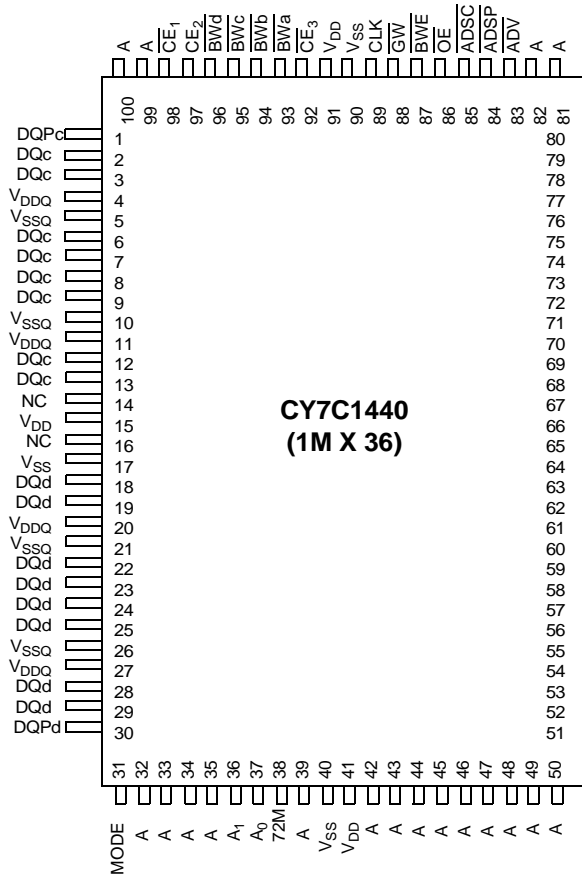



Pin Configurations (continued)

CY7C1440V33 (1M x 36)

	1	2	3	4	5	6	7
A	V _{DDQ}	A	A	$\overline{\text{ADSP}}$	A	A	V _{DDQ}
B	NC	A	A	$\overline{\text{ADSC}}$	A	A	NC
C	NC	A	A	V _{DD}	A	A	NC
D	DQc	DQPc	V _{SS}	NC	V _{SS}	DQPb	DQb
E	DQc	DQc	V _{SS}	$\overline{\text{CE}}_1$	V _{SS}	DQb	DQb
F	V _{DDQ}	DQc	V _{SS}	$\overline{\text{OE}}$	V _{SS}	DQb	V _{DDQ}
G	DQc	DQc	$\overline{\text{BWc}}$	$\overline{\text{ADV}}$	$\overline{\text{BWb}}$	DQb	DQb
H	DQc	DQc	V _{SS}	$\overline{\text{GW}}$	V _{SS}	DQb	DQb
J	V _{DDQ}	V _{DD}	NC	V _{DD}	NC	V _{DD}	V _{DDQ}
K	DQd	DQd	V _{SS}	CLK	V _{SS}	DQa	DQa
L	DQd	DQd	$\overline{\text{BWd}}$	NC	$\overline{\text{BWa}}$	DQa	DQa
M	V _{DDQ}	DQd	V _{SS}	$\overline{\text{BWE}}$	V _{SS}	DQa	V _{DDQ}
N	DQd	DQd	V _{SS}	A1	V _{SS}	DQa	DQa
P	DQd	DQPd	V _{SS}	A0	V _{SS}	DQPa	DQa
R	NC	A	MODE	V _{DD}	NC	A	NC
T	NC	72M	A	A	A	A	ZZ
U	V _{DDQ}	TMS	TDI	TCK	TDO	NC	V _{DDQ}

CY7C1442V33 (2M x 18)

	1	2	3	4	5	6	7
A	V _{DDQ}	A	A	$\overline{\text{ADSP}}$	A	A	V _{DDQ}
B	NC	A	A	$\overline{\text{ADSC}}$	A	A	NC
C	NC	A	A	V _{DD}	A	A	NC
D	DQb	NC	V _{SS}	NC	V _{SS}	DQPb	NC
E	NC	DQb	V _{SS}	$\overline{\text{CE}}_1$	V _{SS}	NC	DQa
F	V _{DDQ}	NC	V _{SS}	$\overline{\text{OE}}$	V _{SS}	DQa	V _{DDQ}
G	NC	DQb	$\overline{\text{BWb}}$	$\overline{\text{ADV}}$	V _{SS}	NC	DQa
H	DQb	NC	V _{SS}	$\overline{\text{GW}}$	V _{SS}	DQa	NC
J	V _{DDQ}	V _{DD}	NC	V _{DD}	NC	V _{DD}	V _{DDQ}
K	NC	DQb	V _{SS}	CLK	V _{SS}	NC	DQa
L	DQb	NC	V _{SS}	NC	$\overline{\text{BWa}}$	DQa	NC
M	V _{DDQ}	DQb	V _{SS}	$\overline{\text{BWE}}$	V _{SS}	NC	V _{DDQ}
N	DQb	NC	V _{SS}	A1	V _{SS}	DQa	NC
P	NC	DQPb	V _{SS}	A0	V _{SS}	NC	DQa
R	NC	A	MODE	V _{DD}	NC	A	NC
T	72M	A	A	A	A	A	ZZ
U	V _{DDQ}	TMS	TDI	TCK	TDO	NC	V _{DDQ}



Pin Configuration (continued)

165-ball Bump FBGA

CY7C1440V33 (1M x 36) – 11 x 15 FBGA

	1	2	3	4	5	6	7	8	9	10	11
A	NC	A	\overline{CE}_1	\overline{BWc}	\overline{BWb}	\overline{CE}_3	\overline{BWE}	\overline{ADSC}	\overline{ADV}	A	NC
B	NC	A	CE_2	\overline{BWd}	\overline{BWa}	CLK	\overline{GW}	\overline{OE}	\overline{ADSP}	A	NC
C	DPc	NC	V_{DDQ}	V_{SS}	V_{SS}	V_{SS}	V_{SS}	V_{SS}	V_{DDQ}	NC	DPb
D	DQc	DQc	V_{DDQ}	V_{DD}	V_{SS}	V_{SS}	V_{SS}	V_{DD}	V_{DDQ}	DQb	DQb
E	DQc	DQc	V_{DDQ}	V_{DD}	V_{SS}	V_{SS}	V_{SS}	V_{DD}	V_{DDQ}	DQb	DQb
F	DQc	DQc	V_{DDQ}	V_{DD}	V_{SS}	V_{SS}	V_{SS}	V_{DD}	V_{DDQ}	DQb	DQb
G	DQc	DQc	V_{DDQ}	V_{DD}	V_{SS}	V_{SS}	V_{SS}	V_{DD}	V_{DDQ}	DQb	DQb
H	NC	V_{SS}	NC	V_{DD}	V_{SS}	V_{SS}	V_{SS}	V_{DD}	NC	NC	ZZ
J	DQd	DQd	V_{DDQ}	V_{DD}	V_{SS}	V_{SS}	V_{SS}	V_{DD}	V_{DDQ}	DQa	DQa
K	DQd	DQd	V_{DDQ}	V_{DD}	V_{SS}	V_{SS}	V_{SS}	V_{DD}	V_{DDQ}	DQa	DQa
L	DQd	DQd	V_{DDQ}	V_{DD}	V_{SS}	V_{SS}	V_{SS}	V_{DD}	V_{DDQ}	DQa	DQa
M	DQd	DQd	V_{DDQ}	V_{DD}	V_{SS}	V_{SS}	V_{SS}	V_{DD}	V_{DDQ}	DQa	DQa
N	DPd	NC	V_{DDQ}	V_{SS}	NC	A	V_{SS}	V_{SS}	V_{DDQ}	NC	DPa
P	NC	72M	A	A	TDI	A1	TDO	A	A	A	A
R	MODE	A	A	A	TMS	A0	TCK	A	A	A	A

CY7C1442V33 (2M x 18) – 11 x 15 FBGA

	1	2	3	4	5	6	7	8	9	10	11
A	NC	A	\overline{CE}_1	\overline{BWb}	NC	\overline{CE}_3	\overline{BWE}	\overline{ADSC}	\overline{ADV}	A	A
B	NC	A	CE_2	NC	\overline{BWa}	CLK	\overline{GW}	\overline{OE}	\overline{ADSP}	A	NC
C	NC	NC	V_{DDQ}	V_{SS}	V_{SS}	V_{SS}	V_{SS}	V_{SS}	V_{DDQ}	NC	DPa
D	NC	DQb	V_{DDQ}	V_{DD}	V_{SS}	V_{SS}	V_{SS}	V_{DD}	V_{DDQ}	NC	DQa
E	NC	DQb	V_{DDQ}	V_{DD}	V_{SS}	V_{SS}	V_{SS}	V_{DD}	V_{DDQ}	NC	DQa
F	NC	DQb	V_{DDQ}	V_{DD}	V_{SS}	V_{SS}	V_{SS}	V_{DD}	V_{DDQ}	NC	DQa
G	NC	DQb	V_{DDQ}	V_{DD}	V_{SS}	V_{SS}	V_{SS}	V_{DD}	V_{DDQ}	NC	DQa
H	NC	V_{SS}	NC	V_{DD}	V_{SS}	V_{SS}	V_{SS}	V_{DD}	NC	NC	ZZ
J	DQb	NC	V_{DDQ}	V_{DD}	V_{SS}	V_{SS}	V_{SS}	V_{DD}	V_{DDQ}	DQa	NC
K	DQb	NC	V_{DDQ}	V_{DD}	V_{SS}	V_{SS}	V_{SS}	V_{DD}	V_{DDQ}	DQa	NC
L	DQb	NC	V_{DDQ}	V_{DD}	V_{SS}	V_{SS}	V_{SS}	V_{DD}	V_{DDQ}	DQa	NC
M	DQb	NC	V_{DDQ}	V_{DD}	V_{SS}	V_{SS}	V_{SS}	V_{DD}	V_{DDQ}	DQa	NC
N	DPb	NC	V_{DDQ}	V_{SS}	NC	A	V_{SS}	V_{SS}	V_{DDQ}	NC	NC
P	NC	72M	A	A	TDI	A1	TDO	A	A	A	A
R	MODE	A	A	A	TMS	A0	TCK	A	A	A	A

CY7C1446 (512K x72)

	1	2	3	4	5	6	7	8	9	10	11
A	DQg	DQg	A	CE ₂	$\overline{\text{ADSP}}$	$\overline{\text{ADSC}}$	$\overline{\text{ADV}}$	$\overline{\text{CE}}_3$	A	DQb	DQb
B	DQg	DQg	$\overline{\text{BWS}}_c$	$\overline{\text{BWS}}_g$	NC	$\overline{\text{BW}}$	A	$\overline{\text{BWS}}_b$	$\overline{\text{BWS}}_f$	DQb	DQb
C	DQg	DQg	$\overline{\text{BWS}}_h$	$\overline{\text{BWS}}_d$	NC	$\overline{\text{CE}}_1$	NC	$\overline{\text{BWS}}_e$	$\overline{\text{BWS}}_a$	DQb	DQb
D	DQg	DQg	V _{SS}	NC	NC	$\overline{\text{OE}}$	NC	$\overline{\text{GW}}$	V _{SS}	DQb	DQb
E	DPg	DPc	V _{DDQ}	V _{DDQ}	V _{DD}	V _{DD}	V _{DD}	V _{DDQ}	V _{DDQ}	DPf	DPb
F	DQc	DQc	V _{SS}	V _{SS}	V _{SS}	NC	V _{SS}	V _{SS}	V _{SS}	DQf	DQf
G	DQc	DQc	V _{DDQ}	V _{DDQ}	V _{DD}	NC	V _{DD}	V _{DDQ}	V _{DDQ}	DQf	DQf
H	DQc	DQc	V _{SS}	V _{SS}	V _{SS}	NC	V _{SS}	V _{SS}	V _{SSQ}	DQf	DQf
J	DQc	DQc	V _{DDQ}	V _{DDQ}	V _{DD}	NC	V _{DD}	V _{DDQ}	V _{DDQ}	DQf	DQf
K	NC	NC	CLK	NC	V _{SS}	V _{SS}	V _{SS}	NC	NC	NC	NC
L	DQh	DQh	V _{DDQ}	V _{DDQ}	V _{DD}	NC	V _{DD}	V _{DDQ}	V _{DDQ}	DQa	DQa
M	DQh	DQh	V _{SS}	V _{SS}	V _{SS}	NC	V _{SS}	V _{SS}	V _{SS}	DQa	DQa
N	DQh	DQh	V _{DDQ}	V _{DDQ}	V _{DD}	NC	V _{DD}	V _{DDQ}	V _{DDQ}	DQa	DQa
P	DQh	DQh	V _{SS}	V _{SS}	V _{SS}	ZZ	V _{SS}	V _{SS}	V _{SS}	DQa	DQa
R	DPd	DPH	V _{DDQ}	V _{DDQ}	V _{DD}	V _{DD}	V _{DD}	V _{DDQ}	V _{DDQ}	DPa	DPe
T	DQd	DQd	V _{SS}	NC	NC	MODE	NC	NC	V _{SS}	DQe	DQe
U	DQd	DQd	NC	A	A	A	A	A	A	DQe	DQe
V	DQd	DQd	A	A	A	A1	A	A	A	DQe	DQe
W	DQd	DQd	TMS	TDI	A	A0	A	TDO	TCK	DQe	DQe

Pin Definitions

Pin Name	I/O	Pin Description
A0 A1 A	Input- Synchronous	Address Inputs used to select one of the address locations. Sampled at the rising edge of the CLK if ADSP or ADSC is active LOW, and CE ₁ , CE ₂ , and CE ₃ are sampled active. A _[1:0] feed the 2-bit counter.
BWa BWb BWc BWd BWe BWf BWg BWh	Input- Synchronous	Byte Write Select Inputs, active LOW. Qualified with BWE to conduct byte writes to the SRAM. Sampled on the rising edge of CLK.
GW	Input- Synchronous	Global Write Enable Input, active LOW. When asserted LOW on the rising edge of CLK, a global write is conducted (ALL bytes are written, regardless of the values on BW _{a,b,c,d,e,f,g,h} and BWE).
BWE	Input- Synchronous	Byte Write Enable Input, active LOW. Sampled on the rising edge of CLK. This signal must be asserted LOW to conduct a byte write.
CLK	Input- Clock	Clock Input. Used to capture all synchronous inputs to the device. Also used to increment the burst counter when ADV is asserted LOW, during a burst operation.



Pin Definitions

Pin Name	I/O	Pin Description
CE ₁	Input-Synchronous	Chip Enable 1 Input, active LOW. Sampled on the rising edge of CLK. Used in conjunction with CE ₂ and CE ₃ to select/deselect the device. ADSP is ignored if CE ₁ is HIGH.
CE ₂	Input-Synchronous	Chip Enable 2 Input, active HIGH. Sampled on the rising edge of CLK. Used in conjunction with CE ₁ and CE ₃ to select/deselect the device.(TQFP Only)
CE ₃	Input-Synchronous	Chip Enable 3 Input, active LOW. Sampled on the rising edge of CLK. Used in conjunction with CE ₁ and CE ₂ to select/deselect the device.(TQFP Only)
OE	Input-Asynchronous	Output Enable, asynchronous input, active LOW. Controls the direction of the I/O pins. When LOW, the I/O pins behave as outputs. When deasserted HIGH, I/O pins are three-stated, and act as input data pins. OE is masked during the first clock of a read cycle when emerging from a deselected state.
ADV	Input-Synchronous	Advance Input signal, sampled on the rising edge of CLK. When asserted, it automatically increments the address in a burst cycle.
ADSP	Input-Synchronous	Address Strobe from Processor, sampled on the rising edge of CLK. When asserted <u>LOW</u> , A is captured in the address registers. <u>A_[14:0]</u> are also loaded into the burst counter. When ADSP and ADSC are both asserted, only ADSP is recognized. ADSP is ignored when CE ₁ is deasserted HIGH.
ADSC	Input-Synchronous	Address Strobe from Controller, sampled on the rising edge of CLK. When asserted LOW, <u>A_[x:0]</u> is captured in the address registers. <u>A_[14:0]</u> are also loaded into the burst counter. When ADSP and ADSC are both asserted, only ADSP is recognized.
MODE	Input-Static	Selects Burst Order. When tied to GND selects linear burst sequence. When tied to V _{DDQ} or left floating selects interleaved burst sequence. This is a strap pin and should remain static during device operation.
ZZ	Input-Asynchronous	ZZ “sleep” Input. This active HIGH input places the device in a non-time critical “sleep” condition with data integrity preserved.This pin can also be left as a NC
DQa, DPa DQb, DPb DQc, DPC DQd, DPd DQe, DPe DQf, DPf DQg, DPg DQh, DPh	I/O-Synchronous	Bidirectional Data I/O lines. As inputs, they feed into an on-chip data register that is triggered by the rising edge of CLK. As outputs, they deliver the data contained in the memory location specified by A during the previous clock rise of the read cycle. The direction of the pins is controlled by OE. When OE is asserted LOW, the pins behave as outputs. When HIGH, DQx and DPx are placed in a three-state condition.DQ a,b,c,d,e,f,g and h are eight bits wide. DP a,b,c,d,e,f,g and h are one bit wide.
TDO	JTAG serial output Synchronous	Serial data-out to the JTAG circuit. Delivers data on the negative edge of TCK. (BGA Only) This pin can be left as a floating pin if JTAG is not used.
TDI	JTAG serial input Synchronous	Serial data-In to the JTAG circuit. Sampled on the rising edge of TCK.(BGA Only) This pin can be left as a floating pin if JTAG is not used.
TMS	Test Mode Select Synchronous	This pin controls the Test Access Port state machine. Sampled on the rising edge of TCK. (BGA Only) This pin can be left as a floating pin if JTAG is not used.
TCK	JTAG serial clock	Serial clock to the JTAG circuit. (BGA Only) This pin can be left as a floating pin if JTAG is not used.
V _{DD}	Power Supply	Power supply inputs to the core of the device. Should be connected to 3.3V –5% +5% power supply.
V _{SS}	Ground	Ground for the core of the device. Should be connected to ground of the system.
V _{DDQ}	I/O Power Supply	Power supply for the I/O circuitry. Should be connected to a 2.375(min) to Vdd(max)
V _{SSQ}	I/O Ground	Ground for the I/O circuitry. Should be connected to ground of the system.
72M		No connects. Reserved for address expansion.
NC	–	No connects.

Introduction

Functional Overview

All synchronous inputs pass through input registers controlled by the rising edge of the clock. All data outputs pass through output registers controlled by the rising edge of the clock. Maximum access delay from the clock rise (t_{CO}) is 2.2 ns (300-MHz device).

The CY7C1440V33/CY7C1446V33/CY7C1446V33 support secondary cache in systems utilizing either a linear or interleaved burst sequence. The interleaved burst order supports Pentium® and i486™ processors. The linear burst sequence is suited for processors that utilize a linear burst sequence. The burst order is user selectable, and is determined by sampling the MODE input. Accesses can be initiated with either the Processor Address Strobe (ADSP) or the Controller Address Strobe (ADSC). Address advancement through the burst sequence is controlled by the ADV input. A two-bit on-chip wraparound burst counter captures the first address in a burst sequence and automatically increments the address for the rest of the burst access.

Byte write operations are qualified with the Byte Write Enable (BWE) and Byte Write Select ($BW_{a,b,c,d}$ for CY7C1440V33, $BW_{a,b}$ for CY7C1442V33, and $BW_{a,b,c,d,e,f,g,h}$ for CY7C1446V33) inputs. A Global Write Enable (GW) overrides all byte write inputs and writes data to all four bytes. All writes are simplified with on-chip synchronous self-timed write circuitry.

Synchronous Chip Selects (\overline{CE}_1 , CE_2 , \overline{CE}_3 for TQFP/ \overline{CE}_1 for BGA) and an asynchronous Output Enable (\overline{OE}) provide for easy bank selection and output three-state control. ADSP is ignored if CE_1 is HIGH.

Single Read Accesses

This access is initiated when the following conditions are satisfied at clock rise: (1) ADSP or ADSC is asserted LOW, (2) chip selects are all asserted active, and (3) the write signals (GW, BWE) are all deasserted HIGH. ADSP is ignored if CE_1 is HIGH. The address presented to the address inputs is stored into the address advancement logic and the Address Register while being presented to the memory core. The corresponding data is allowed to propagate to the input of the Output Registers. At the rising edge of the next clock the data is allowed to propagate through the output register and onto the data bus within 2.2 ns (300-MHz device) if \overline{OE} is active LOW. The only exception occurs when the SRAM is emerging from a deselected state to a selected state, its outputs are always three-stated during the first cycle of the access. After the first cycle of the access, the outputs are controlled by the OE signal. Consecutive single read cycles are supported. Once the SRAM is deselected at clock rise by the chip select and either ADSP or ADSC signals, its output will three-state immediately.

Single Write Accesses Initiated by \overline{ADSP}

This access is initiated when both of the following conditions are satisfied at clock rise: (1) ADSP is asserted LOW, and (2) chip select is asserted active. The address presented is loaded into the address register and the address

advancement logic while being delivered to the RAM core. The write signals (GW, BWE, and BW_x) and ADV inputs are ignored during this first cycle.

ADSP triggered write accesses require two clock cycles to complete. If GW is asserted LOW on the second clock rise, the data presented to the DQx inputs is written into the corresponding address location in the RAM core. If GW is HIGH, then the write operation is controlled by BWE and BW_x signals. The CY7C1440V33/CY7C1442V33/CY7C1446V33 provides byte write capability that is described in the Write Cycle Description table. Asserting the Byte Write Enable input (BWE) with the selected Byte Write ($BW_{a,b,c,d}$ for CY7C1440V33, $BW_{a,b,c,d,e,f,g,h}$ for CY7C1446V33, and $BW_{a,b}$ for CY7C1446V33) input will selectively write to only the desired bytes. Bytes not selected during a byte write operation will remain unaltered. A synchronous self-timed write mechanism has been provided to simplify the write operations.

Because the CY7C1440V33/CY7C1442V33/CY7C1446V33 is a common I/O device, the Output Enable (\overline{OE}) must be deasserted HIGH before presenting data to the DQ inputs. Doing so will three-state the output drivers. As a safety precaution, DQ are automatically three-stated whenever a write cycle is detected, regardless of the state of \overline{OE} .

Single Write Accesses Initiated by \overline{ADSC}

ADSC write accesses are initiated when the following conditions are satisfied: (1) ADSC is asserted LOW, (2) ADSP is deasserted HIGH, (3) chip select is asserted active, and (4) the appropriate combination of the write inputs (GW, BWE, and BW_x) are asserted active to conduct a write to the desired byte(s). ADSC triggered write accesses require a single clock cycle to complete. The address presented to $A_{[x:0]}$ ($x = 20$ for CY7C1440V33, $x = 21$ for CY7C1442V33, and $x = 19$ for CY7C1446V33) is loaded into the address register and the address advancement logic while being delivered to the RAM core. The ADV input is ignored during this cycle. If a global write is conducted, the data presented to the $DQ_{[x:0]}$ is written into the corresponding address location in the RAM core. If a byte write is conducted, only the selected bytes are written. Bytes not selected during a byte write operation will remain unaltered. A synchronous self-timed write mechanism has been provided to simplify the write operations.

Because the CY7C1440V33/CY7C1442V33/CY7C1446V33 is a common I/O device, the Output Enable (\overline{OE}) must be deasserted HIGH before presenting data to the $DQ_{[x:0]}$ inputs. Doing so will three-state the output drivers. As a safety precaution, $DQ_{[x:0]}$ are automatically three-stated whenever a write cycle is detected, regardless of the state of \overline{OE} .

Burst Sequences

The CY7C1440V33/CY7C1442V33/CY7C1446V33 provides a two-bit wrap around counter, fed by $A_{[1:0]}$, that implements either an interleaved or linear burst sequence. The interleaved burst sequence is designed specifically to support Intel Pentium applications. The linear burst sequence is designed to support processors that follow a linear burst sequence. The burst sequence is user selectable through the MODE input.



Asserting \overline{ADV} LOW at clock rise will automatically increment the burst counter to the next address in the burst sequence. Both read and write burst operations are supported.

Interleaved Burst Sequence

First Address	Second Address	Third Address	Fourth Address
$A_{[1:0]}$	$A_{[1:0]}$	$A_{[1:0]}$	$A_{[1:0]}$
00	01	10	11
01	00	11	10
10	11	00	01
11	10	01	00

Linear Burst Sequence

First Address	Second Address	Third Address	Fourth Address
$A_{[1:0]}$	$A_{[1:0]}$	$A_{[1:0]}$	$A_{[1:0]}$
00	01	10	11
01	10	11	00
10	11	00	01
11	00	01	10

Sleep Mode

The ZZ input pin is an asynchronous input. Asserting ZZ places the SRAM in a power conservation "sleep" mode. Two clock cycles are required to enter into or exit from this "sleep" mode. While in this mode, data integrity is guaranteed. Accesses pending when entering the "sleep" mode are not considered valid nor is the completion of the operation guaranteed. The device must be deselected prior to entering the "sleep" mode. \overline{CEs} , ADSP, and ADSC must remain inactive for the duration of t_{ZZREC} after the ZZ input returns LOW.

ZZ Mode Electrical Characteristics

Parameter	Description	Test Conditions	Min.	Max.	Unit
I_{DDZZ}	Snooze mode standby current	$ZZ \geq V_{DD} - 0.2V$		15	mA
t_{ZZS}	Device operation to ZZ	$ZZ \geq V_{DD} - 0.2V$		$2t_{CYC}$	ns
t_{ZZREC}	ZZ recovery time	$ZZ \leq 0.2V$	$2t_{CYC}$		ns

Cycle Descriptions^[2, 3, 4, 5]

Next Cycle	Add. Used	ZZ	\overline{CE}_3	\overline{CE}_2	\overline{CE}_1	ADSP	ADSC	ADV	OE	DQ	Write
Unselected	None	L	X	X	1	X	0	X	X	Hi-Z	X
Unselected	None	L	1	X	0	0	X	X	X	Hi-Z	X
Unselected	None	L	X	0	0	0	X	X	X	Hi-Z	X
Unselected	None	L	1	X	0	1	0	X	X	Hi-Z	X
Unselected	None	L	X	0	0	1	0	X	X	Hi-Z	X
Begin Read	External	L	0	1	0	0	X	X	X	Hi-Z	X
Begin Read	External	L	0	1	0	1	0	X	X	Hi-Z	Read
Continue Read	Next	L	X	X	X	1	1	0	1	Hi-Z	Read
Continue Read	Next	L	X	X	X	1	1	0	0	DQ	Read
Continue Read	Next	L	X	X	1	X	1	0	1	Hi-Z	Read
Continue Read	Next	L	X	X	1	X	1	0	0	DQ	Read
Suspend Read	Current	L	X	X	X	1	1	1	1	Hi-Z	Read
Suspend Read	Current	L	X	X	X	1	1	1	0	DQ	Read
Suspend Read	Current	L	X	X	1	X	1	1	1	Hi-Z	Read
Suspend Read	Current	L	X	X	1	X	1	1	0	DQ	Read

Notes:

- X = "Don't Care." 1 = HIGH, 0 = LOW.
- Write is defined by BWE, BWx, and GW. See Write Cycle Descriptions table.
- The DQ pins are controlled by the current cycle and the OE signal. OE is asynchronous and is not sampled with the clock.
- \overline{CE}_1 , \overline{CE}_2 , and \overline{CE}_3 are available only in the TQFP package. BGA package has a single chip select \overline{CE}_1 .



Cycle Descriptions^[2, 3, 4, 5]

Next Cycle	Add. Used	ZZ	\overline{CE}_3	\overline{CE}_2	\overline{CE}_1	\overline{ADSP}	\overline{ADSC}	\overline{ADV}	\overline{OE}	DQ	Write
Begin Write	Current	L	X	X	X	1	1	1	X	Hi-Z	Write
Begin Write	Current	L	X	X	1	X	1	1	X	Hi-Z	Write
Begin Write	External	L	0	1	0	1	0	X	X	Hi-Z	Write
Continue Write	Next	L	X	X	X	1	1	0	X	Hi-Z	Write
Continue Write	Next	L	X	X	1	X	1	0	X	Hi-Z	Write
Suspend Write	Current	L	X	X	X	1	1	1	X	Hi-Z	Write
Suspend Write	Current	L	X	X	1	X	1	1	X	Hi-Z	Write
ZZ "sleep"	None	H	X	X	X	X	X	X	X	Hi-Z	X

Write Cycle Descriptions^[2, 3]

Function (CY7C1440V33)	\overline{GW}	\overline{BWE}	\overline{BWd}	\overline{BWc}	\overline{BWb}	\overline{BWA}
Read	1	1	X	X	X	X
Read	1	0	1	1	1	1
Write Byte 0–DQa	1	0	1	1	1	0
Write Byte 1–DQb	1	0	1	1	0	1
Write Bytes 1, 0	1	0	1	1	0	0
Write Byte 2–DQc	1	0	1	0	1	1
Write Bytes 2, 0	1	0	1	0	1	0
Write Bytes 2, 1	1	0	1	0	0	1
Write Bytes 2, 1, 0	1	0	1	0	0	0
Write Byte 3–DQd	1	0	0	1	1	1
Write Bytes 3, 0	1	0	0	1	1	0
Write Bytes 3, 1	1	0	0	1	0	1
Write Bytes 3, 1, 0	1	0	0	1	0	0
Write Bytes 3, 2	1	0	0	0	1	1
Write Bytes 3, 2, 0	1	0	0	0	1	0
Write Bytes 3, 2, 1	1	0	0	0	0	1
Write All Bytes	1	0	0	0	0	0
Write All Bytes	0	X	X	X	X	X

Function (CY7C1446V33)	\overline{GW}	\overline{BWE}	\overline{BWb}	\overline{BWA}
Read	1	1	X	X
Read	1	0	1	1
Write Byte 0–DQ _[7:0] and DP ₀	1	0	1	0
Write Byte 1–DQ _[15:8] and DP ₁	1	0	0	1
Write All Bytes	1	0	0	0
Write All Bytes	0	X	X	X

IEEE 1149.1 Serial Boundary Scan (JTAG)

The CY7C1440V33/CY7C1442V33 incorporates a serial boundary scan Test Access Port (TAP) in the FBGA package only. The TQFP package does not offer this functionality. This port operates in accordance with IEEE Standard 1149.1-1990, but does not have the set of functions required for full 1149.1

compliance. These functions from the IEEE specification are excluded because their inclusion places an added delay in the critical speed path of the SRAM. Note that the TAP controller functions in a manner that does not conflict with the operation of other devices using 1149.1 fully compliant TAPs. The TAP operates using JEDEC standard 3.3V I/O logic levels.

Disabling the JTAG Feature

It is possible to operate the SRAM without using the JTAG feature. To disable the TAP controller, TCK must be tied LOW (V_{SS}) to prevent clocking of the device. TDI and TMS are internally pulled up and may be unconnected. They may alternately be connected to V_{DD} through a pull-up resistor. TDO should be left unconnected. Upon power-up, the device will come up in a reset state which will not interfere with the operation of the device.

Test Access Port–Test Clock

The test clock is used only with the TAP controller. All inputs are captured on the rising edge of TCK. All outputs are driven from the falling edge of TCK.

Test Mode Select

The TMS input is used to give commands to the TAP controller and is sampled on the rising edge of TCK. It is allowable to leave this pin unconnected if the TAP is not used. The pin is pulled up internally, resulting in a logic HIGH level.

Test Data-In (TDI)

The TDI pin is used to serially input information into the registers and can be connected to the input of any of the registers. The register between TDI and TDO is chosen by the instruction that is loaded into the TAP instruction register. For information on loading the instruction register, see the TAP Controller State Diagram. TDI is internally pulled up and can be unconnected if the TAP is unused in an application. TDI is connected to the Most Significant Bit (MSB) on any register.

Test Data Out (TDO)

The TDO output pin is used to serially clock data-out from the registers. The e output is active depending upon the current state of the TAP state machine (see TAP Controller State Diagram). The output changes on the falling edge of TCK. TDO is connected to the Least Significant Bit (LSB) of any register.

Performing a TAP Reset

A Reset is performed by forcing TMS HIGH (V_{DD}) for five rising edges of TCK. This RESET does not affect the operation of the SRAM and may be performed while the SRAM is operating. At power-up, the TAP is reset internally to ensure that TDO comes up in a high-Z state.

TAP Registers

Registers are connected between the TDI and TDO pins and allow data to be scanned into and out of the SRAM test circuitry. Only one register can be selected at a time through the instruction registers. Data is serially loaded into the TDI pin on the rising edge of TCK. Data is output on the TDO pin on the falling edge of TCK.

Instruction Register

Three-bit instructions can be serially loaded into the instruction register. This register is loaded when it is placed between the TDI and TDO pins as shown in the TAP Controller Block Diagram. Upon power-up, the instruction register is loaded with the IDCODE instruction. It is also loaded with the IDCODE instruction if the controller is placed in a reset state as described in the previous section.

When the TAP controller is in the CaptureIR state, the two least significant bits are loaded with a binary “01” pattern to allow for fault isolation of the board level serial test path.

Bypass Register

To save time when serially shifting data through registers, it is sometimes advantageous to skip certain states. The bypass register is a single-bit register that can be placed between TDI and TDO pins. This allows data to be shifted through the SRAM with minimal delay. The bypass register is set LOW (V_{SS}) when the BYPASS instruction is executed.

Boundary Scan Register

The boundary scan register is connected to all the input and output pins on the SRAM. Several no connect (NC) pins are also included in the scan register to reserve pins for higher density devices. The x36 configuration has a 70-bit-long register, and the x18 configuration has a 51-bit-long register.

The boundary scan register is loaded with the contents of the RAM Input and Output ring when the TAP controller is in the Capture-DR state and is then placed between the TDI and TDO pins when the controller is moved to the Shift-DR state. The EXTEST, SAMPLE/PRELOAD and SAMPLE Z instructions can be used to capture the contents of the Input and Output ring.

The Boundary Scan Order tables show the order in which the bits are connected. Each bit corresponds to one of the bumps on the SRAM package. The MSB of the register is connected to TDI, and the LSB is connected to TDO.

Identification (ID) Register

The ID register is loaded with a vendor-specific, 32-bit code during the Capture-DR state when the IDCODE command is loaded in the instruction register. The IDCODE is hardwired into the SRAM and can be shifted out when the TAP controller is in the Shift-DR state. The ID register has a vendor code and other information described in the Identification Register Definitions table.

TAP Instruction Set

Eight different instructions are possible with the three-bit instruction register. All combinations are listed in the Instruction Code table. Three of these instructions are listed as RESERVED and should not be used. The other five instructions are described in detail below.

The TAP controller used in this SRAM is not fully compliant to the 1149.1 convention because some of the mandatory 1149.1 instructions are not fully implemented. The TAP controller cannot be used to load address, data or control signals into the SRAM and cannot preload the Input or Output buffers. The SRAM does not implement the 1149.1 commands EXTEST or INTEST or the PRELOAD portion of SAMPLE/PRELOAD; rather it performs a capture of the Inputs and Output ring when these instructions are executed.

Instructions are loaded into the TAP controller during the Shift-IR state when the instruction register is placed between TDI and TDO. During this state, instructions are shifted through the instruction register through the TDI and TDO pins. To execute the instruction once it is shifted in, the TAP controller needs to be moved into the Update-IR state.



EXTEST

EXTEST is a mandatory 1149.1 instruction which is to be executed whenever the instruction register is loaded with all 0s. EXTEST is not implemented in the TAP controller, and therefore this device is not compliant to the 1149.1 standard.

The TAP controller does recognize an all-0 instruction. When an EXTEST instruction is loaded into the instruction register, the SRAM responds as if a SAMPLE/PRELOAD instruction has been loaded. There is one difference between the two instructions. Unlike the SAMPLE/PRELOAD instruction, EXTEST places the SRAM outputs in a High-Z state.

IDCODE

The IDCODE instruction causes a vendor-specific, 32-bit code to be loaded into the instruction register. It also places the instruction register between the TDI and TDO pins and allows the IDCODE to be shifted out of the device when the TAP controller enters the Shift-DR state. The IDCODE instruction is loaded into the instruction register upon power-up or whenever the TAP controller is given a test logic reset state.

SAMPLE Z

The SAMPLE Z instruction causes the boundary scan register to be connected between the TDI and TDO pins when the TAP controller is in a Shift-DR state. It also places all SRAM outputs into a High-Z state.

SAMPLE/PRELOAD

SAMPLE/PRELOAD is a 1149.1 mandatory instruction. The PRELOAD portion of this instruction is not implemented, so the TAP controller is not fully 1149.1-compliant.

When the SAMPLE/PRELOAD instructions loaded into the instruction register and the TAP controller in the Capture-DR state, a snapshot of data on the inputs and output pins is captured in the boundary scan register.

The user must be aware that the TAP controller clock can only operate at a frequency up to 10 MHz, while the SRAM clock

operates more than an order of magnitude faster. Because there is a large difference in the clock frequencies, it is possible that during the Capture-DR state, an input or output will undergo a transition. The TAP may then try to capture a signal while in transition (metastable state). This will not harm the device, but there is no guarantee as to the value that will be captured. Repeatable results may not be possible.

To guarantee that the boundary scan register will capture the correct value of a signal, the SRAM signal must be stabilized long enough to meet the TAP controller's capture set-up plus hold times (TCS and TCH). The SRAM clock input might not be captured correctly if there is no way in a design to stop (or slow) the clock during a SAMPLE/PRELOAD instruction. If this is an issue, it is still possible to capture all other signals and simply ignore the value of the CK and \overline{CK} captured in the boundary scan register.

Once the data is captured, it is possible to shift out the data by putting the TAP into the Shift-DR state. This places the boundary scan register between the TDI and TDO pins.

Note that since the PRELOAD part of the command is not implemented, putting the TAP into the Update to the Update-DR state while performing a SAMPLE/PRELOAD instruction will have the same effect as the Pause-DR command.

Bypass

When the BYPASS instruction is loaded in the instruction register and the TAP is placed in a Shift-DR state, the bypass register is placed between the TDI and TDO pins. The advantage of the BYPASS instruction is that it shortens the boundary scan path when multiple devices are connected together on a board.

Reserved

These instructions are not implemented but are reserved for future use. Do not use these instructions.

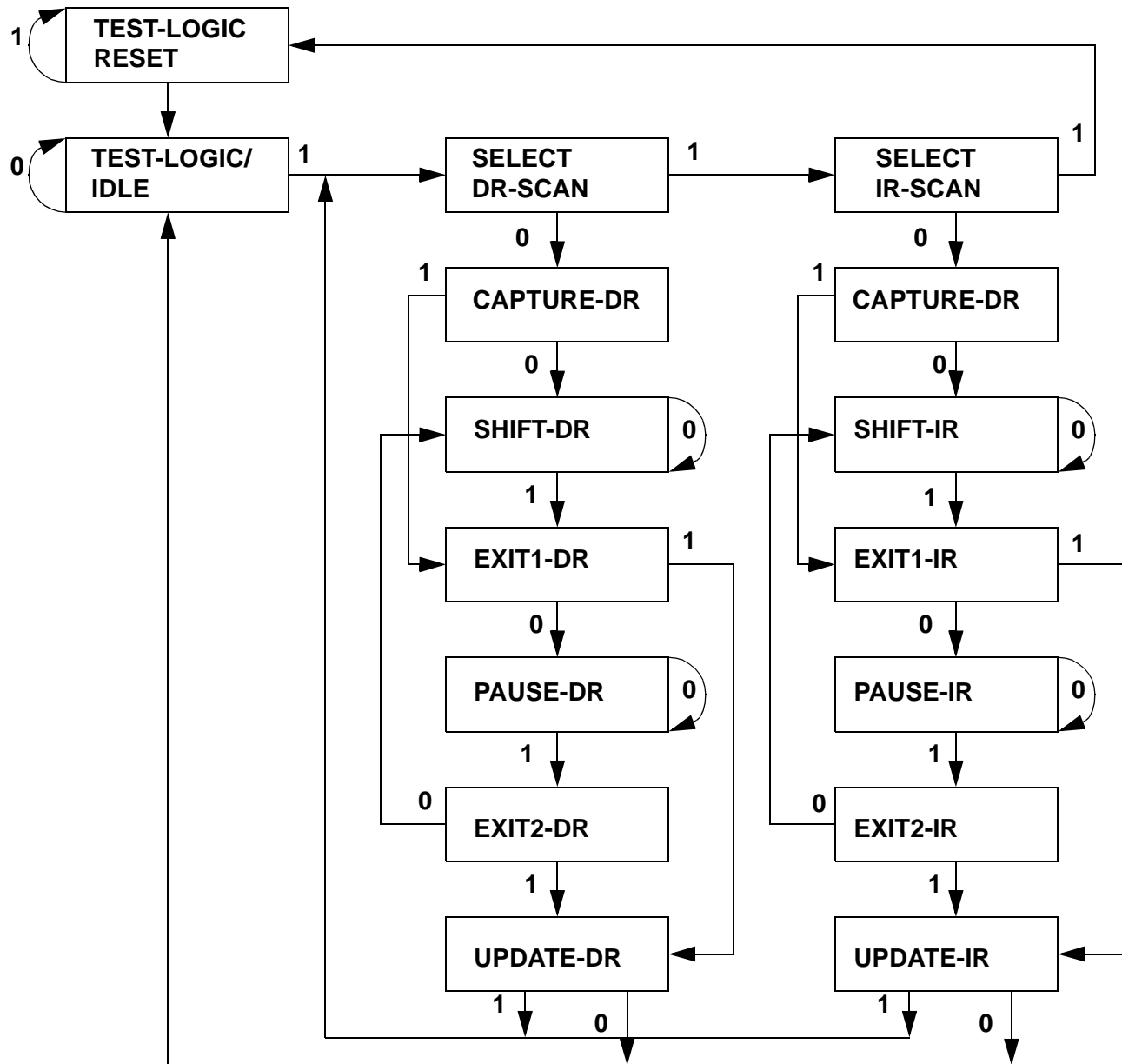
TAP Controller State Diagram^[76]

Note:

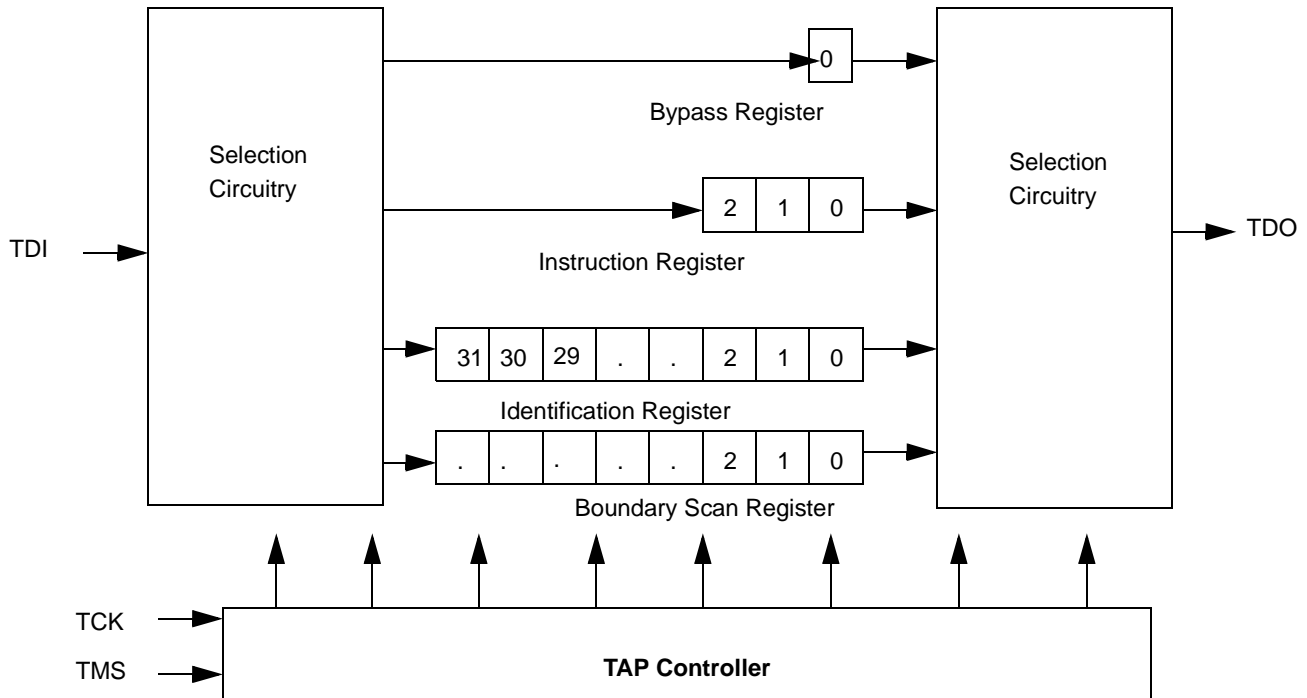
6. The 0/1 next to each state represents the value at TMS at the rising edge of TCK.

TAP Controller Block Diagram

TAP Electrical Characteristics Over the Operating Range^[7, 10]

Parameter	Description	Test Conditions	Min.	Max.	Unit
V _{OH1}	Output HIGH Voltage	I _{OH} = -4.0 mA	2.4		V
V _{OH2}	Output HIGH Voltage	I _{OH} = -100 μA	3.0		V
V _{OL1}	Output LOW Voltage	I _{OL} = 8.0 mA		0.4	V
V _{OL2}	Output LOW Voltage	I _{OL} = 100 μA		0.2	V
V _{IH}	Input HIGH Voltage		1.8	V _{DD} + 0.3	V
V _{IL}	Input LOW Voltage		-0.5	0.8	V
I _X	Input Load Current	GND ≤ V _I ≤ V _{DDQ}	-5	5	μA

TAP AC Switching Characteristics Over the Operating Range^[8, 9]

Parameters	Description	Min.	Max.	Unit
t _{TCYC}	TCK Clock Cycle Time	100		ns
t _{TF}	TCK Clock Frequency		10	MHz
t _{TH}	TCK Clock HIGH	40		ns
t _{TL}	TCK Clock LOW	40		ns
Set-up Times				
t _{TMSS}	TMS Set-up to TCK Clock Rise	10		ns
t _{TDIS}	TDI Set-up to TCK Clock Rise	10		ns

Notes:

7. All voltage referenced to ground.
8. t_{CS} and t_{CH} refer to the set-up and hold time requirements of latching data from the boundary scan register.
9. Test conditions are specified using the load in TAP AC test conditions. TR/TF = 1 ns.
10. Overshoot: V_{IH(AC)} ≤ V_{DD} + 1.5V for t ≤ t_{TCYC}/2; undershoot: V_{IL(AC)} ≤ 0.5V for t ≤ t_{TCYC}/2; power-up: V_{IH} < 2.6V and V_{DD} < 2.4V and V_{DDQ} < 1.4V for t < 200 ms.

TAP AC Switching Characteristics Over the Operating Range^[8, 9]

Parameters	Description	Min.	Max.	Unit
t_{CS}	Capture Set-up to TCK Rise	10		ns
Hold Times				
t_{TMSH}	TMS Hold after TCK Clock Rise	10		ns
t_{TDIH}	TDI Hold after Clock Rise	10		ns
t_{CH}	Capture Hold after Clock Rise	10		ns
Output Times				
t_{TDOV}	TCK Clock LOW to TDO Valid		20	ns
t_{TDOX}	TCK Clock LOW to TDO Invalid	0		ns

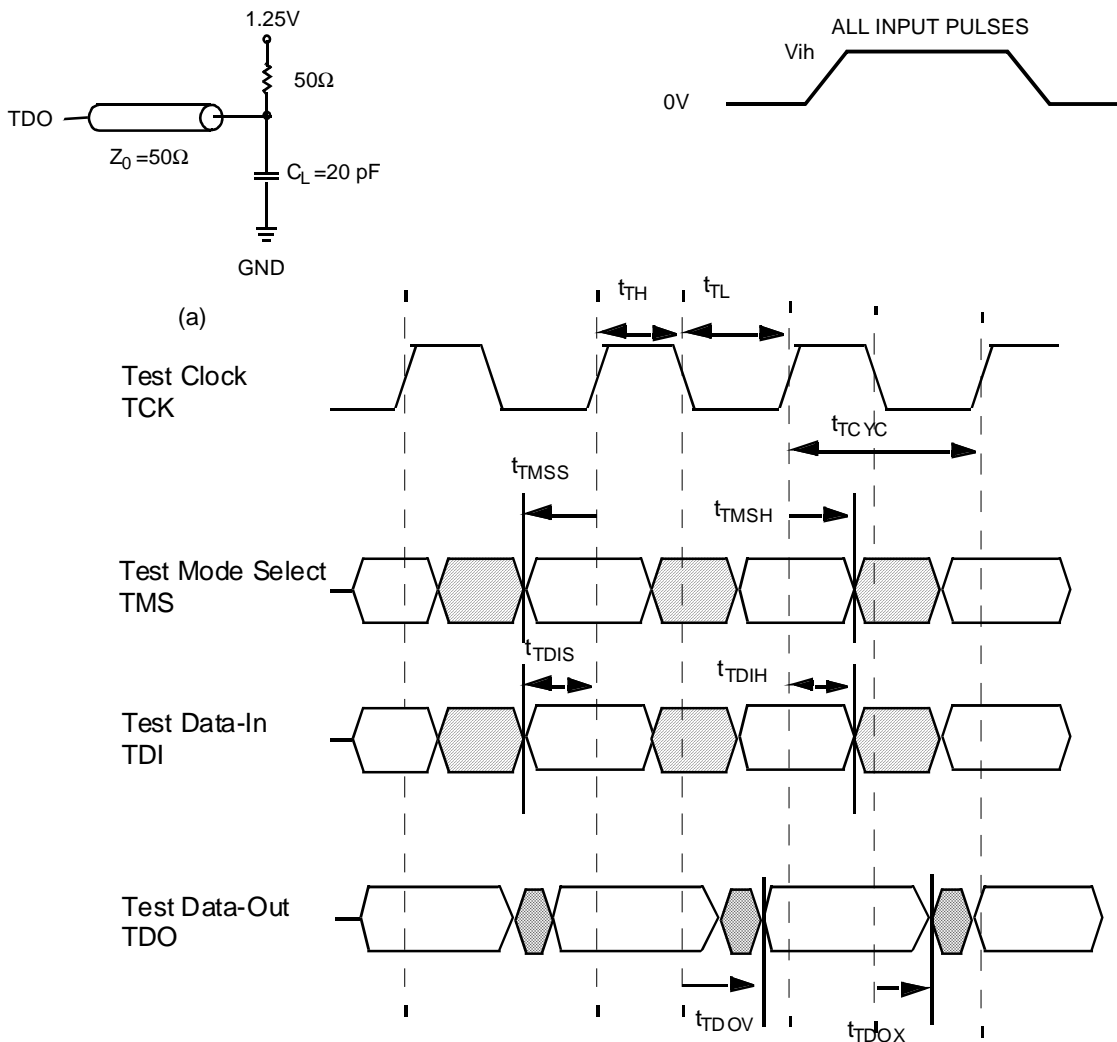
TAP Timing and Test Conditions



Maximum Ratings

(Above which the useful life may be impaired. For user guidelines, not tested.)

- Storage Temperature -55°C to +150°C
- Ambient Temperature with Power Applied..... -55°C to +125°C
- Supply Voltage on V_{DD} Relative to GND..... -0.3V to +4.6V
- DC Voltage Applied to Outputs in High-Z State^[11]..... -0.5V to V_{DDQ} + 0.5V
- DC Input Voltage^[11]..... -0.5V to V_{DDQ} + 0.5V

- Current into Outputs (LOW)..... 20 mA
- Static Discharge Voltage..... > 2001V (per MIL-STD-883, Method 3015)
- Latch-up Current..... > 200 mA

Operating Range

Range	Ambient Temp. ^[12]	V _{DD}	V _{DDQ}
Com'l	0–70°C	3.3V +5% /-5%	2.375V(Min) V _{DD} (Max)

Electrical Characteristics Over the Operating Range

Parameter	Description	Test Conditions	Min.	Max.	Unit
V _{DD}	Power Supply Voltage		3.135	3.465	V
V _{DDQ}	I/O Supply Voltage		2.375	V _{DD}	V
V _{OH} Output HIGH Voltage		V _{DD} = Min., I _{OH} = -4.0 mA	V _{DDQ} =3.3V	2.4	V
		V _{DD} = Min., I _{OH} = -1.0 mA	V _{DDQ} =2.5V	2.0	V
V _{OL} Output LOW Voltage		V _{DD} = Min., I _{OL} = 8.0 mA	V _{DDQ} =3.3V		0.4
		V _{DD} = Min., I _{OL} = 1.0 mA	V _{DDQ} =2.5V		0.4
V _{IH} Input HIGH Voltage			V _{DDQ} =3.3 V	2.0	V
			V _{DDQ} =2.5V	1.7	V
V _{IL} Input LOW Voltage ^[11]			V _{DDQ} =3.3V	-0.3	0.8
			V _{DDQ} =2.5V	-0.3	0.7
I _X	Input Load Current	GND ≤ V _I ≤ V _{DDQ}		5	μA
	Input Current of MODE			30	μA
I _{OZ}	Output Leakage Current	GND ≤ V _I ≤ V _{DDQ} , Output Disabled		5	μA
I _{DD}	V _{DD} Operating Supply	V _{DD} = Max., I _{OUT} = 0 mA, f = f _{MAX} = 1/t _{CYC}	300 MHz		TBD
			250MHz		TBD
			200MHz		TBD
			166Mhz		TBD
I _{SB1}	Automatic CE Power-down Current—TTL Inputs	Max. V _{DD} , Device Deselected, V _{IN} ≥ V _{IH} or V _{IN} ≤ V _{IL} f = f _{MAX} = 1/t _{CYC}	300 MHz		TBD
			250MHz		TBD
			200MHz		TBD
			166Mhz		TBD
I _{SB2}	Automatic CE Power-down Current—CMOS Inputs	Max. V _{DD} , Device Deselected, V _{IN} ≤ 0.3V or V _{IN} ≥ V _{DDQ} - 0.3V, f = 0	All speed grades		TBD
I _{SB3}	Automatic CE Power-down Current—CMOS Inputs	Max. V _{DD} , Device Deselected, or V _{IN} £ 0.3V or V _{IN} ≥ V _{DDQ} - 0.3V f = f _{MAX} = 1/t _{CYC}	300 MHz		TBD
			250MHz		TBD
			200MHz		TBD
			166Mhz		TBD
I _{SB4}	Automatic CE Power-down Current—TTL Inputs	Max. V _{DD} , Device Deselected, V _{IN} ≥ V _{IH} or V _{IN} ≤ V _{IL} , f = 0	All speed grades		TBD

Notes:

- 11. Minimum voltage equals -2.0V for pulse durations of less than 20 ns.
- 12. T_A is the ambient temperature.

Capacitance^[13]

Parameter	Description	Test Conditions	Max.	Unit
C _{IN}	Input Capacitance	T _A = 25°C, f = 1 MHz, V _{DD} = 3.3V, V _{DDQ} = 2.5V	TBD	pF
C _{CLK}	Clock Input Capacitance		TBD	pF
C _{I/O}	Input/Output Capacitance		TBD	pF

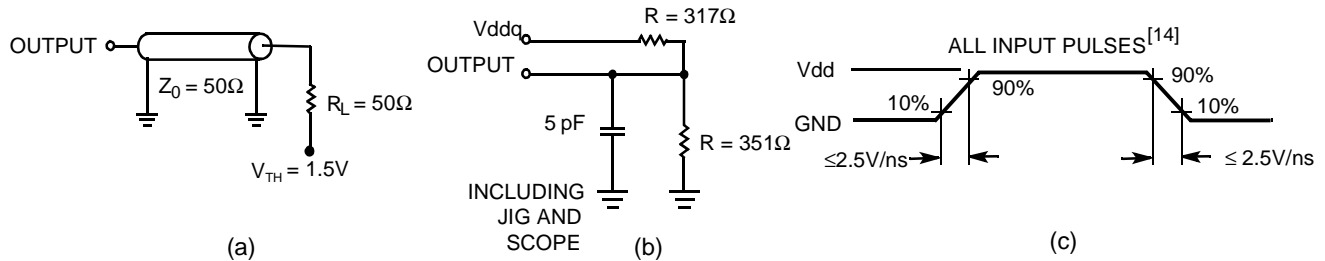
AC Test Loads and Waveforms

Switching Characteristics Over the Operating Range^[15, 16, 17]

Parameter	Description	-300		-250		-200		-167		Unit
		Min.	Max.	Min.	Max.	Min.	Max.	Min.	Max.	
t _{CYC}	Clock Cycle Time	3.3		4.0		5.0		6.0		ns
t _{CH}	Clock HIGH	1.5		1.5		2.0		2.4		ns
t _{CL}	Clock LOW	1.5		1.5		2.0		2.4		ns
t _{AS}	Address Set-up Before CLK Rise	1.5		1.5		1.5		1.5		ns
t _{AH}	Address Hold After CLK Rise	0.5		0.5		0.5		0.5		ns
t _{CO}	Data Output Valid After CLK Rise		2.3		2.7		3.0		3.5	ns
t _{DOH}	Data Output Hold After CLK Rise	1.5		1.5		1.5		1.5		ns
t _{ADS}	ADSP, ADSC Set-up Before CLK Rise	1.5		1.5		1.5		1.5		ns
t _{ADH}	ADSP, ADSC Hold After CLK Rise	0.5		0.5		0.5		0.5		ns
t _{WES}	BWE, GW, BW _x Set-up Before CLK Rise	1.5		1.5		1.5		1.5		ns
t _{WEH}	BWE, GW, BW _x Hold After CLK Rise	0.5		0.5		0.5		0.5		ns
t _{ADVS}	ADV Set-up Before CLK Rise	1.5		1.5		1.5		1.5		ns
t _{ADVH}	ADV Hold After CLK Rise	0.5		0.5		0.5		0.5		ns
t _{DS}	Data Input Set-up Before CLK Rise	1.5		1.5		1.5		1.5		ns
t _{DH}	Data Input Hold After CLK Rise	0.5		0.5		0.5		0.5		ns
t _{CES}	Chip Enable Set-up	1.5		1.5		1.5		1.5		ns
t _{CEH}	Chip Enable Hold After CLK Rise	0.5		0.5		0.5		0.5		ns
t _{CHZ}	Clock to High-Z ^[16]		2.3		2.3		3.0		3.0	ns
t _{CLZ}	Clock to Low-Z ^[16]	1.5		1.5		1.5		1.5		ns
t _{EOHZ}	OE HIGH to Output High-Z ^[16, 17]		2.3		2.3		3.0		3.0	ns
t _{EO LZ}	OE LOW to Output Low-Z ^[16, 17]	0		0		0		0		ns
t _{EOV}	OE LOW to Output Valid ^[16]		2.3		2.7		3.0		3.5	ns

Notes:

13. Tested initially and after any design or process changes that may affect these parameters.

14. Input waveform should have a slew rate of 1 V/ns.

15. Unless otherwise noted, test conditions assume signal transition time of 2.5 ns or less, timing reference levels of 1.25V, input pulse levels of 0 to 2.5V, and output loading of the specified I_{OL}/I_{OH} and load capacitance. Shown in (a), (b), and (c) of AC Test Loads.

16. t_{CHZ}, t_{CLZ}, t_{EOV}, t_{EO LZ}, and t_{EOHZ} are specified with a load capacitance of 5 pF as in (b) of AC Test Loads. Transition is measured ± 200 mV from steady-state voltage.

17. At any given voltage and temperature, t_{EOHZ} is less than t_{EO LZ} and t_{CHZ} is less than t_{CLZ}.

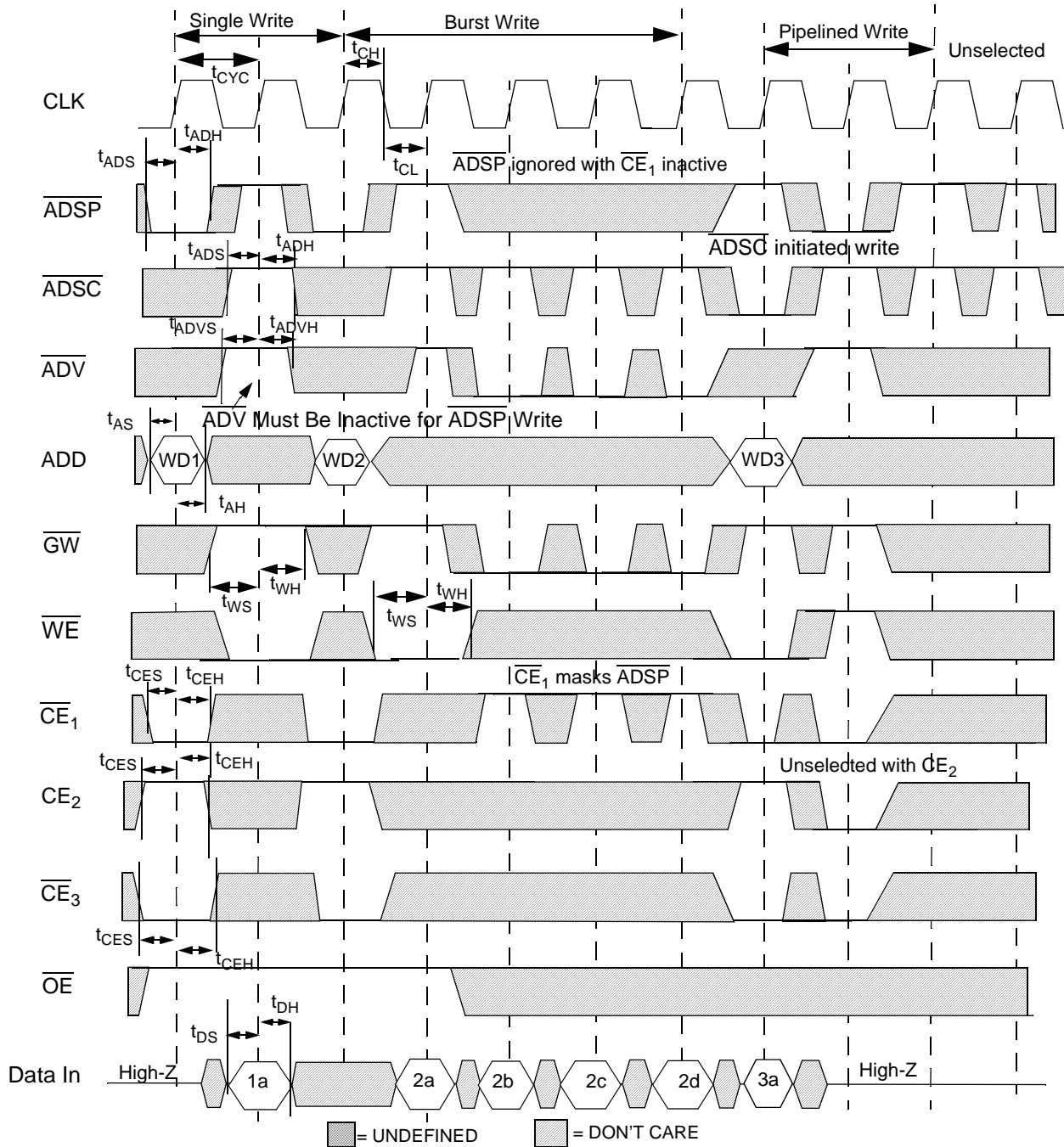
Switching Waveforms
Write Cycle Timing^[5, 18, 19]

Notes:

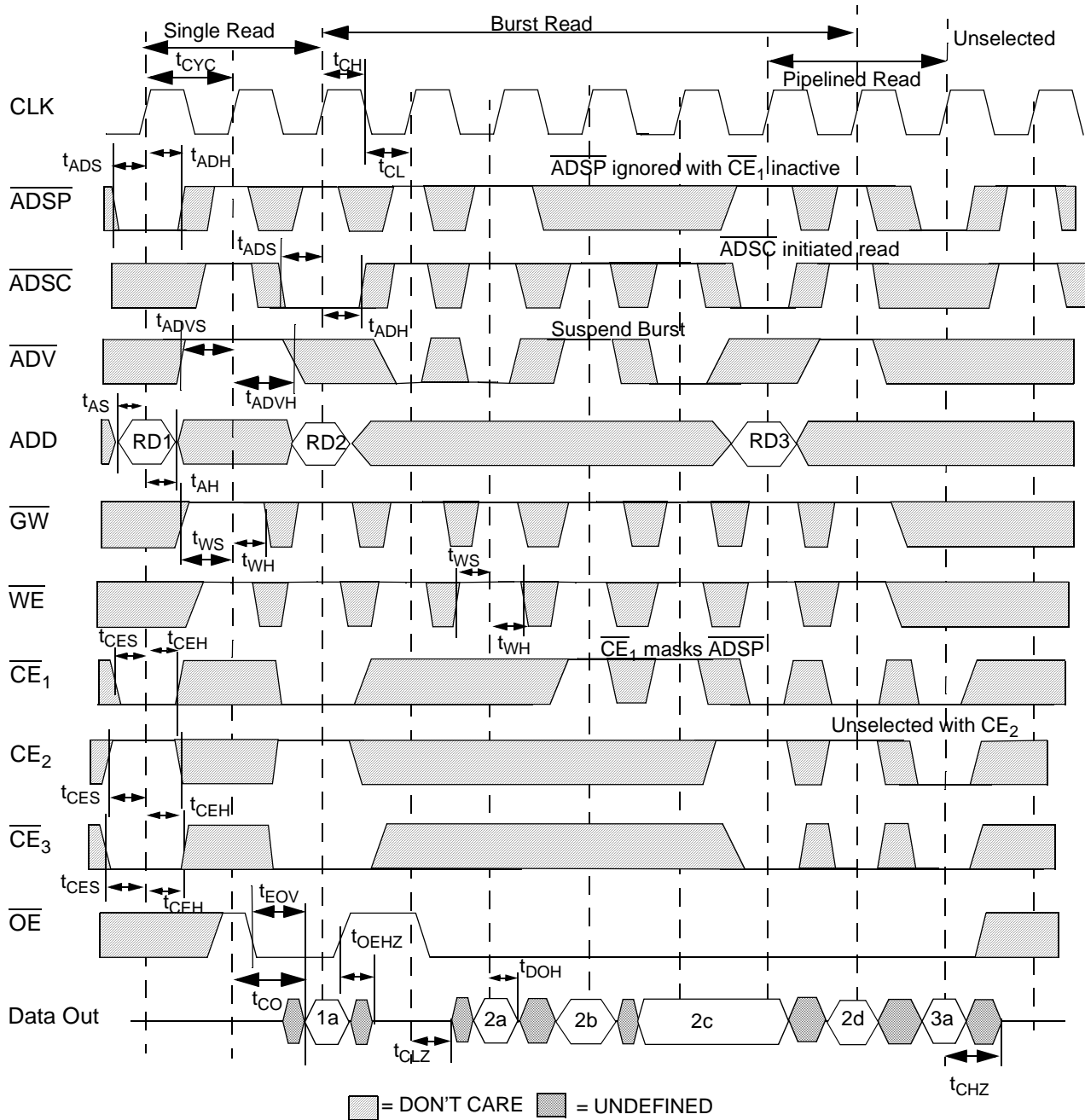
- 18. \overline{WE} is the combination of \overline{BWE} , \overline{BWx} , and \overline{GW} to define a write cycle (see Write Cycle Descriptions table).
- 19. WDx stands for Write Data to Address X.

Switching Waveforms (continued)
Read Cycle Timing^[5, 18, 20]

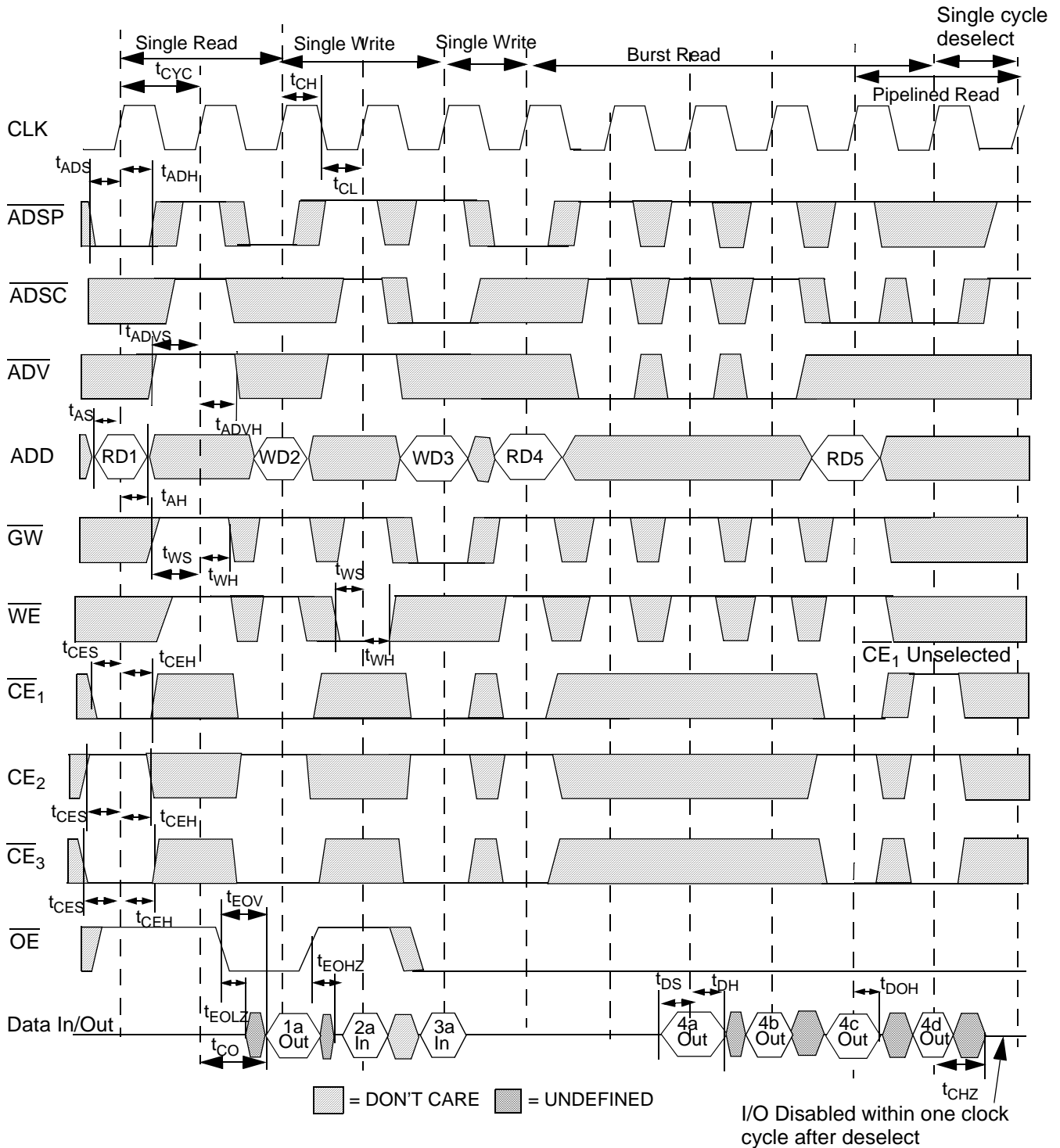
Note:

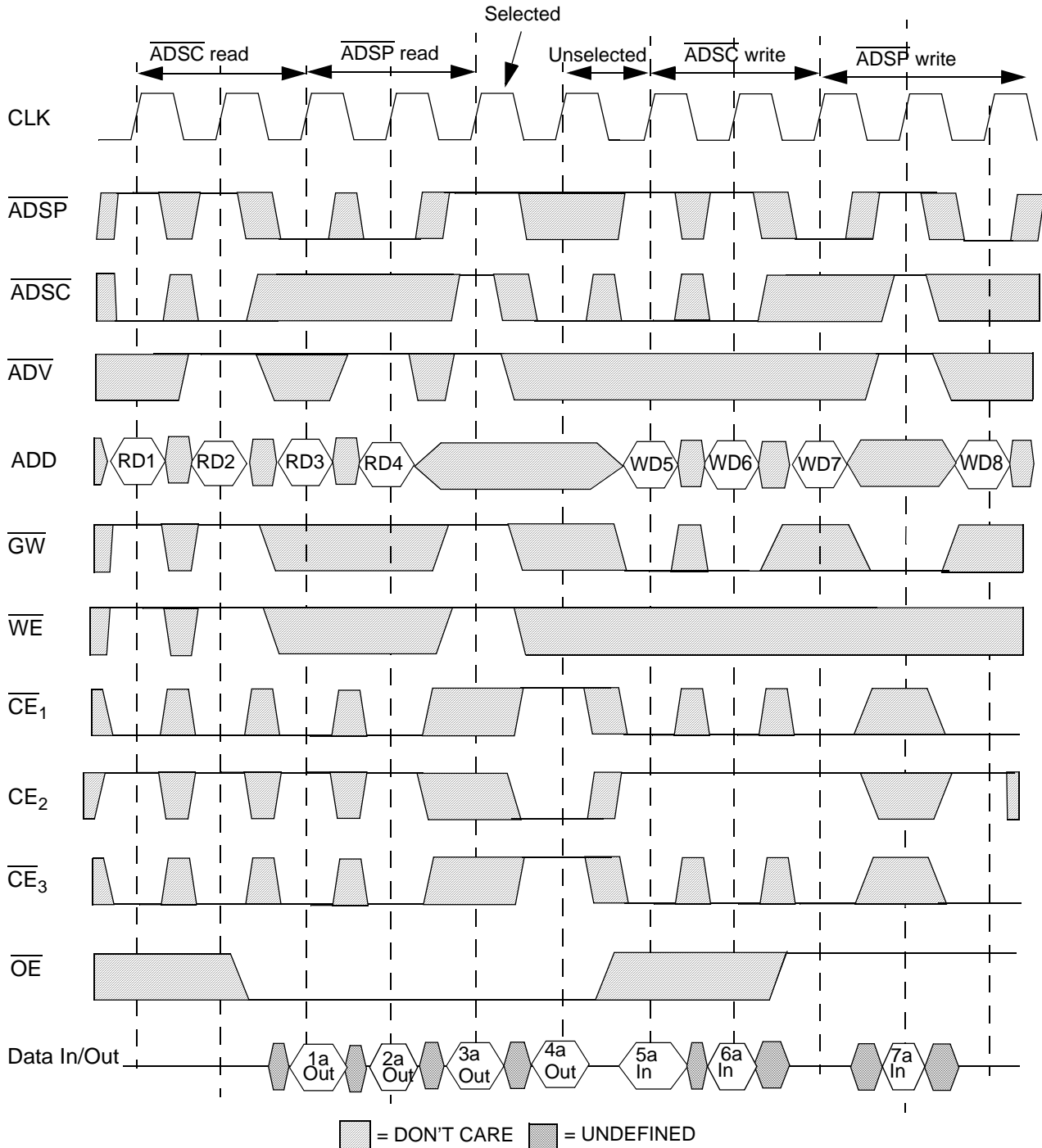
20. RDx stands for Read Data from Address X.

Switching Waveforms (continued)
Read/Write Cycle Timing^[5, 18, 19, 20]

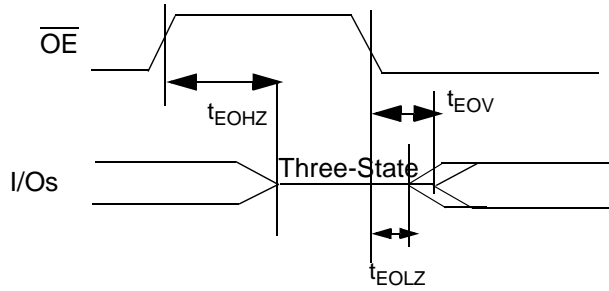
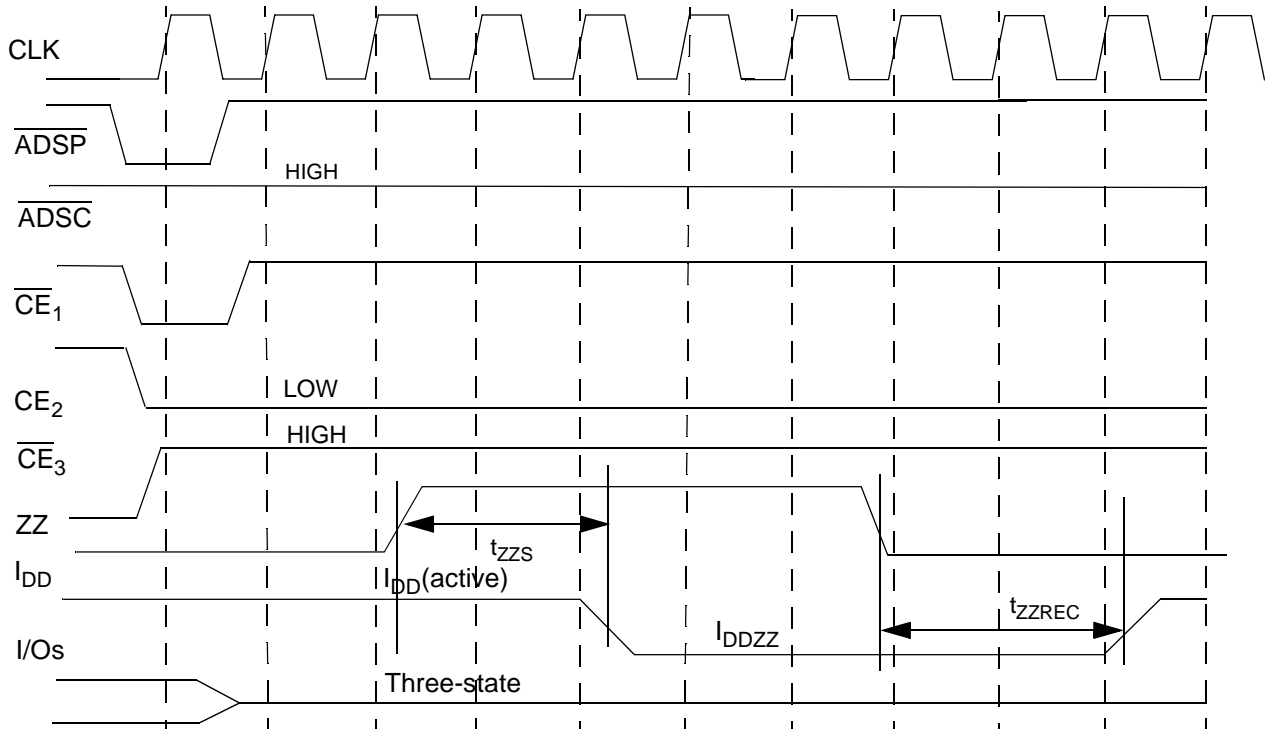
Switching Waveforms (continued)
Pipelined Read/Write Timing^[5, 18, 19, 20]

Switching Waveforms (continued)
OE Switching Waveforms

ZZ Mode Timing [5, 21, 22]

Notes:

21. Device must be deselected when entering ZZ mode. See Cycle Descriptions Table for all possible signal conditions to deselect the device.
22. I/Os are in three-state when exiting ZZ sleep mode.

Ordering Information

Speed (MHz)	Ordering Code	Package Name	Package Type	Operating Range
300	CY7C1440V33-300AC CY7C1446V33-300AC	A101	100-lead 14 x 20 x 1.4 mm Thin Quad Flat Pack	Commercial
	CY7C1440V33-300BGC CY7C1446V33-300BGC	BG119	119-ball BGA (14 x 22 x 2.4 mm)	
	CY7C1446V33-300BX	BG209	209-ball FBGA (14 x 22 x 2.2mm)	
	CY7C1440V33-300BZC CY7C1446V33-300BZC	BB165C	165-ball FBGA (15 x 17 mm)	
250	CY7C1440V33-250AC CY7C1446V33-250AC	A101	100-lead 14 x 20 x 1.4 mm Thin Quad Flat Pack	
	CY7C1440V33-250BGC CY7C1446V33-250BGC	BG119	119-ball BGA (14 x 22 x 2.4 mm)	
	CY7C1446V33-250BX	BG209	209-ball FBGA (14 x 22 x 2.2mm)	
	CY7C1440V33-250BZC CY7C1446V33-250BZC	BB165C	165-ball FBGA (15 x 17 mm)	
200	CY7C1440V33-200AC CY7C1446V33-200AC	A101	100-lead 14 x 20 x 1.4 mm Thin Quad Flat Pack	
	CY7C1440V33-200BGC CY7C1446V33-200BGC	BG119	119-ball BGA (14 x 22 x 2.4 mm)	
	CY7C1446V33-200BX	BG209	209-ball FBGA (14 x 22 x 2.2mm)	
	CY7C1440V33-200BZC CY7C1446V33-200BZC	BB165C	165-ball FBGA (15 x 17 mm)	
167	CY7C1440V33-167AC CY7C1446V33-167AC	A101	100-lead 14 x 20 x 1.4 mm Thin Quad Flat Pack	
	CY7C1440V33-167BGC CY7C1446V33-167BGC	BG119	119-ball BGA (14 x 22 x 2.4 mm)	
	CY7C1446V33-167BX	BG209	209-ball FBGA (14 x 22 x 2.2mm)	
	CY7C1440V33-167BZC CY7C1446V33-167BZC	BB165C	165-ball FBGA (15 x 17 mm)	

Package Diagrams

100-lead Thin Plastic Quad Flatpack (14 x 20 x 1.4 mm) A101

DIMENSIONS ARE IN MILLIMETERS.

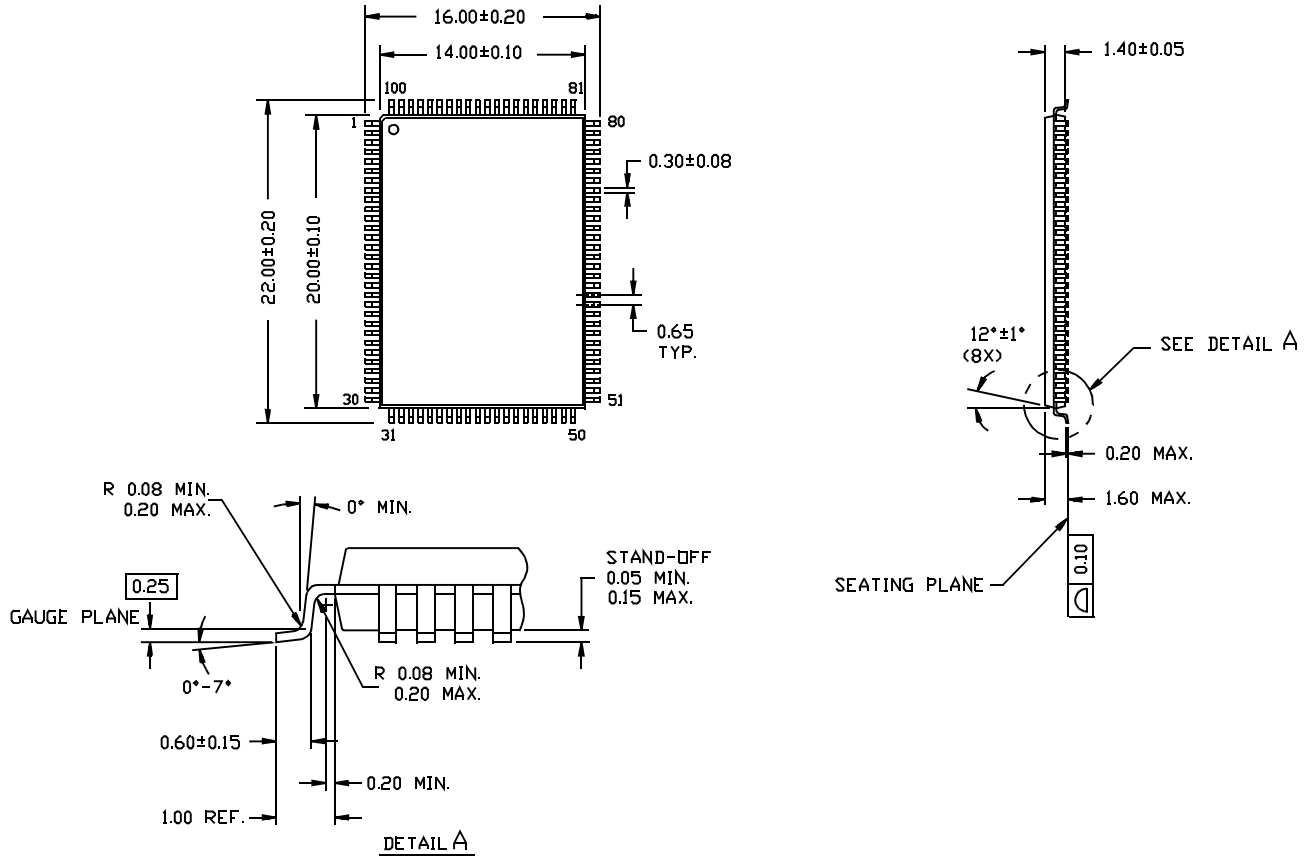

51-85050-A

Package Diagrams (continued)

119-Lead PBGA (14 x 22 x 2.4 mm) BG119

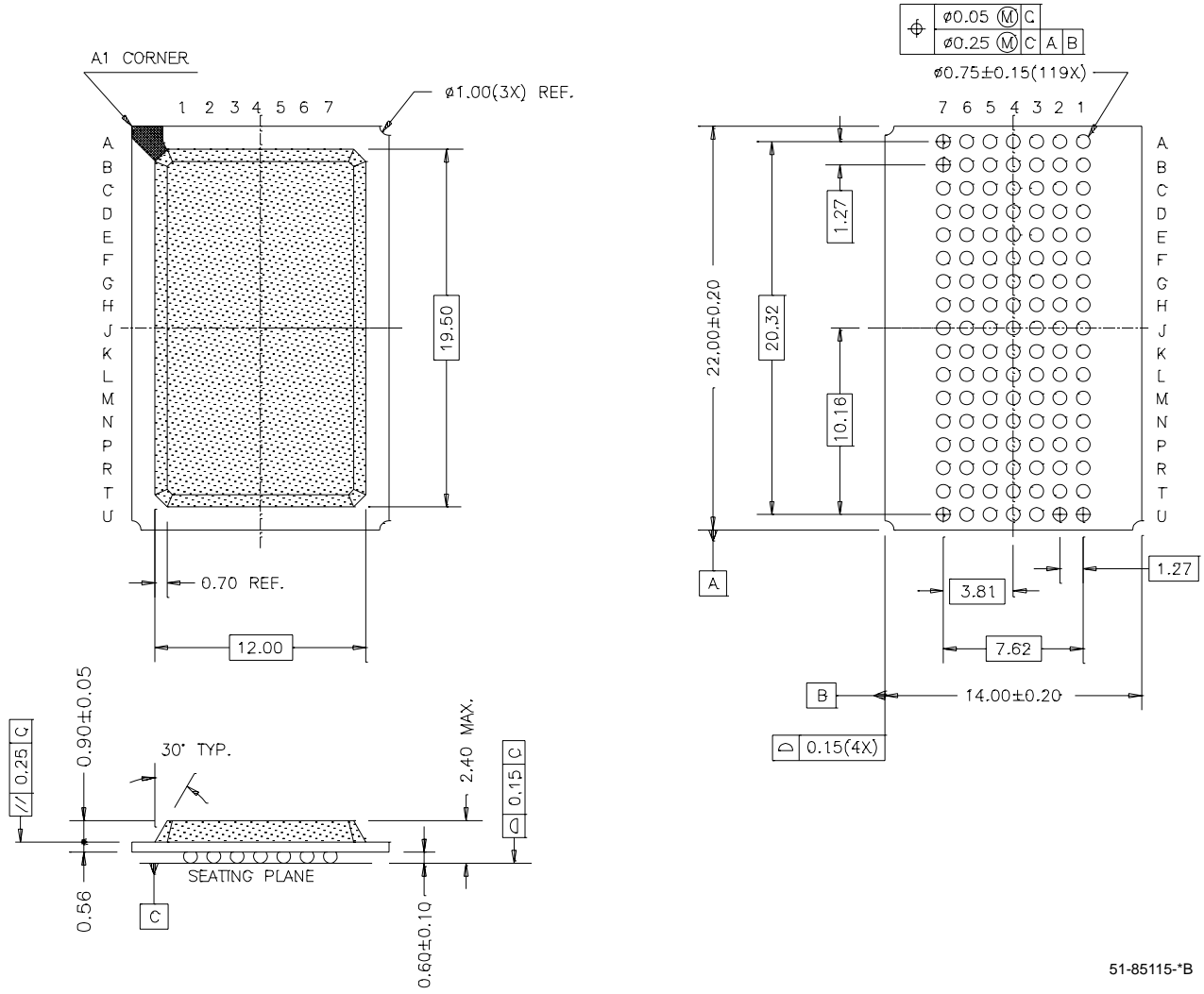

51-85115*B

Package Diagrams (continued)

165-ball FBGA (15 x 17 x 1.20 mm) BB165C

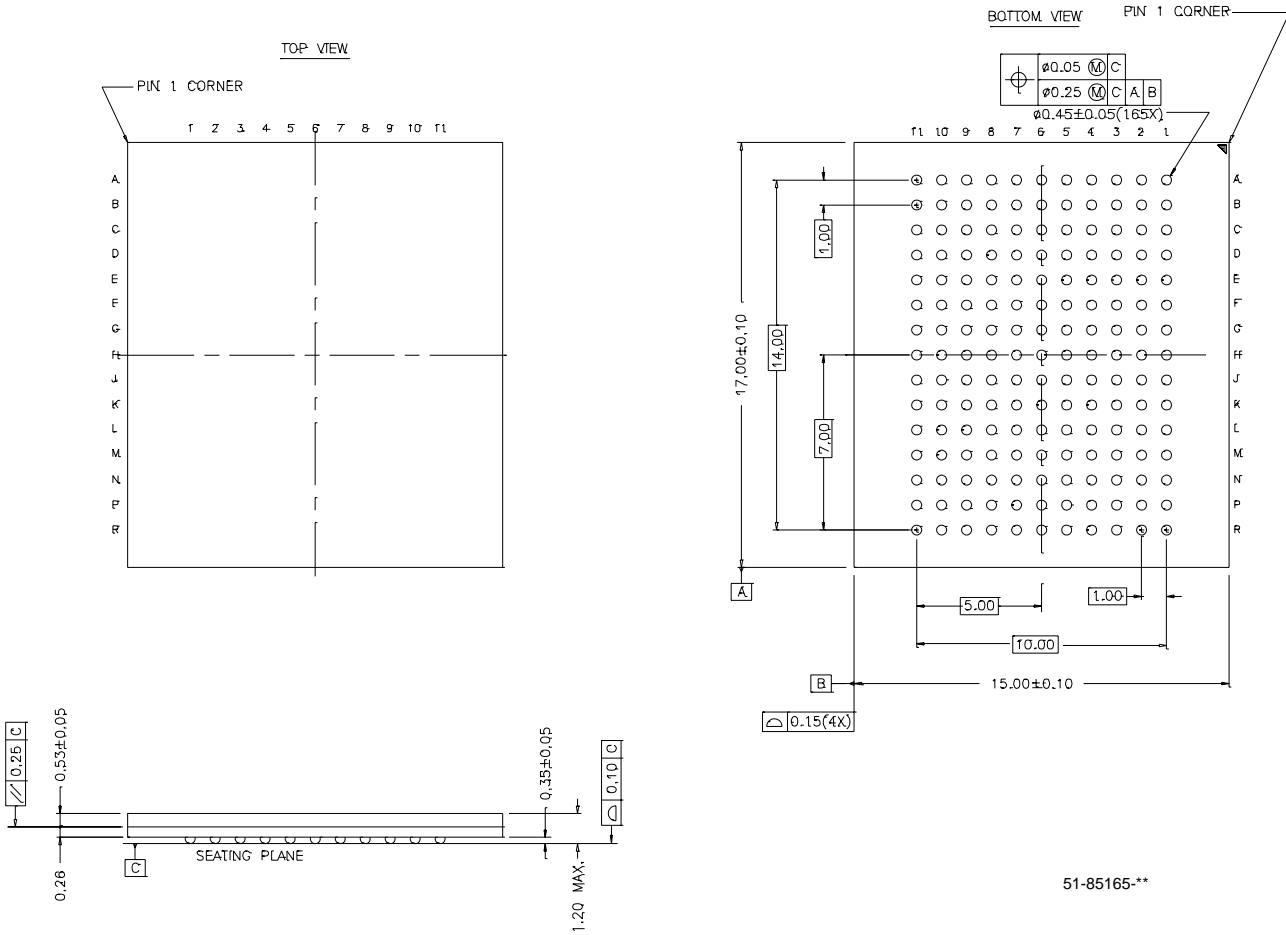

51-85165-**

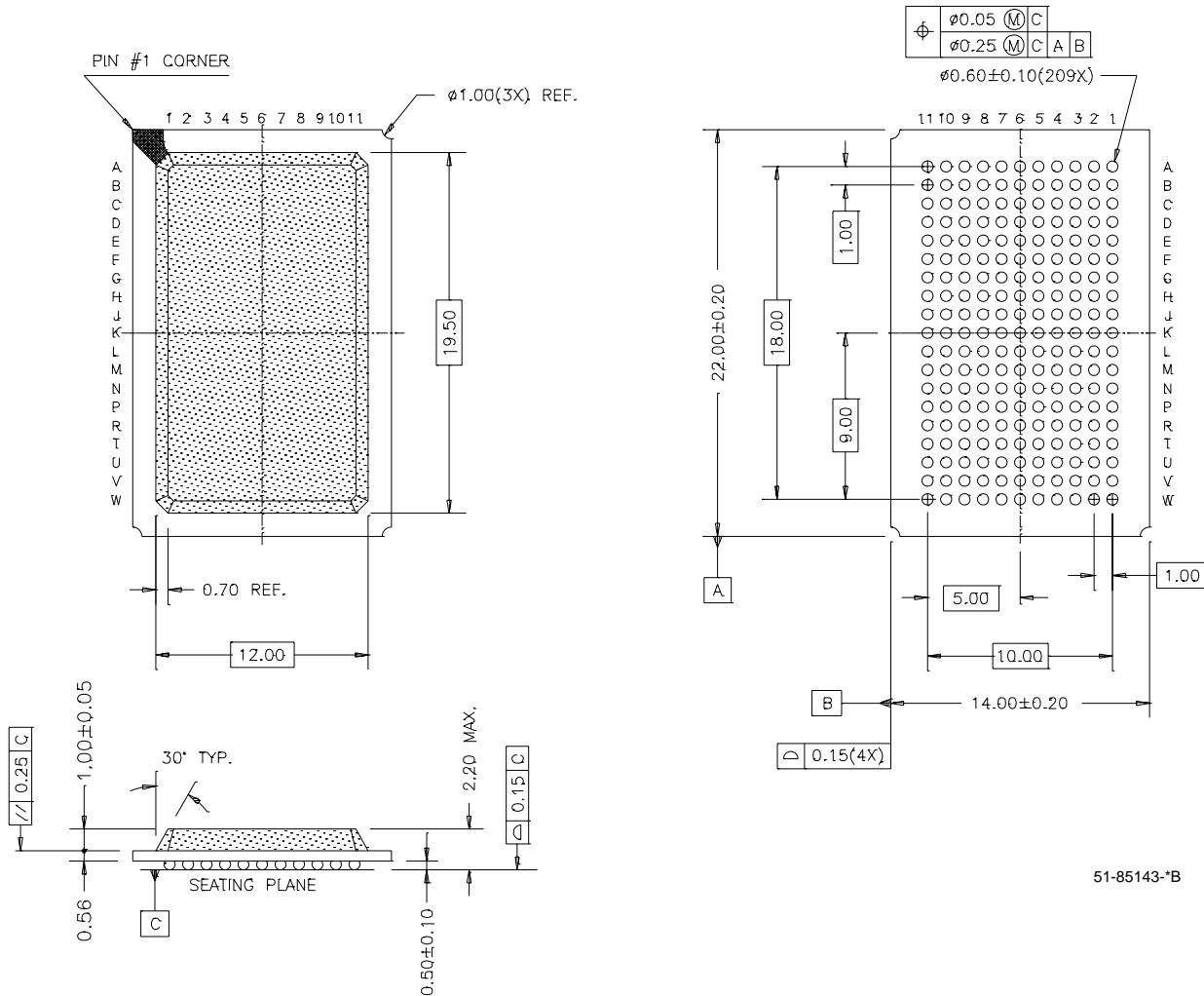
Package Diagrams (continued)
209-Lead PBGA (14 x 22 x 2.20 mm) BG209

Intel and Pentium are registered trademarks, and i486 is a trademark, of Intel Corporation. No Bus Latency and NoBL are trademarks of Cypress Semiconductor Corporation. ZBT is a trademark of Integrated Device Technology. All products and company names mentioned in this document may be the trademarks of their respective holders.



Document History Page

Document Title: CY7C1440V33/CY7C1442V33/CY7C1446V33 1M x 36/2M x 18/512K x 72 Pipelined SRAM				
Document Number: 38-05184				
REV.	ECN No.	Issue Date	Orig. of Change	Description of Change
**	113761	04/11/02	PKS	New Data Sheet
*A	116916	08/07/02	FLX	Correct B ₁₁ pin of 165 FBGA package Shaded 300-MHz device information
*B	121474	11/14/02	DSG	Updated package diagrams 51-85115 (BG119) to rev. *B, 51-85143 (BG209) to rev. *B