

High-Reliability Power Inductors ML513PYA

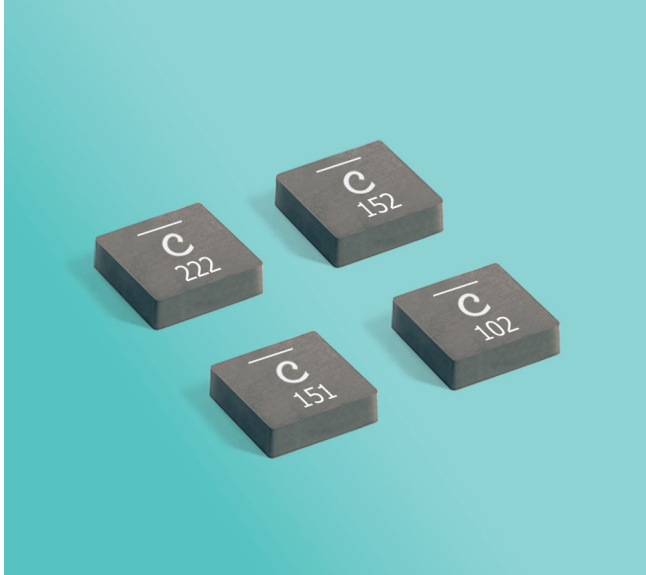

- High temperature materials allow operation in ambient temperatures up to 155°C
- Passes vibration testing to 80 G and shock testing to 1000 G
- High current and very low DCR
- Soft saturation makes them ideal for VRM/VRD applications.

Core material Composite

Terminations Tin-silver (96.5/3.5) over copper.

Weight 0.83 g

Ambient temperature -55°C to +105°C with Irms current, +105°C to +155°C with derated current

Storage temperature Component: -55°C to +155°C.
Tape and reel packaging: -55°C to +80°C

Resistance to soldering heat Max three 40 second reflows at +260°C, parts cooled to room temperature between cycles

Moisture Sensitivity Level (MSL) 1 (unlimited floor life at <30°C / 85% relative humidity)

Enhanced crush-resistant packaging 500 per 7" reel
Plastic tape: 16 mm wide, 0.30 mm thick, 12 mm pocket spacing, 2.2 mm pocket depth

Part number ¹	Inductance ² ±20% (µH)	DCR (mOhms) ³		SRF (MHz) ⁴		Isat ⁵ (A)	Irms (A) ⁶	
		typ	max	min	typ		20°C rise	40°C rise
ML513PYA151MLZ	0.15	1.9	2.5	129	161	46.0	13.5	18.0
ML513PYA271MLZ	0.27	2.9	3.8	90	112	30.0	11.3	15.8
ML513PYA331MLZ	0.33	4.0	5.2	70	88	28.0	10.5	15.0
ML513PYA471MLZ	0.47	5.3	6.4	59	72	24.3	9.0	12.8
ML513PYA681MLZ	0.68	7.9	9.5	43	54	22.3	7.5	9.8
ML513PYA102MLZ	1.0	9.8	10.8	37	46	16.4	6.0	8.3
ML513PYA122MLZ	1.2	11.5	12.8	34	42	14.5	5.3	7.5
ML513PYA152MLZ	1.5	16.7	18.6	30	37	11.7	4.5	6.8
ML513PYA222MLZ	2.2	24.4	27.5	23	29	11.2	3.8	5.3

1. When ordering, please specify **testing** code:

ML513PYA222MLZ

Testing: Z = COTS

H = Screening per Coilcraft CP-SA-10001

N = Screening per Coilcraft CP-SA-10004

2. Inductance tested at 100 kHz, 0.1 Vrms using an Agilent/HP 4192A.

3. DCR measured using a micro-ohmmeter.

4. SRF measured using an Agilent/HP 4395A or equivalent.

5. Typical dc current at which the inductance drops 30% from its value without current.

6. Typical current that causes the specified temperature rise from 25°C ambient.

7. Electrical specifications at 25°C.

Refer to Doc 362 "Soldering Surface Mount Components" before soldering.

Irms Testing

Irms testing was performed on a 0.060" thick pcb with 4 oz. copper traces optimized to minimize additional temperature rise.

Temperature rise is highly dependent on many factors including pcb land pattern, trace size, and proximity to other components. Therefore temperature rise should be verified in application conditions.

ML513PYA Series (7020)

L vs Current

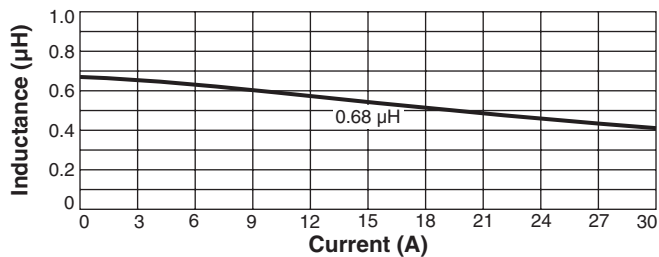
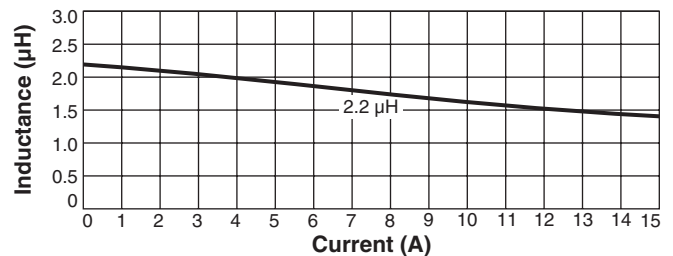
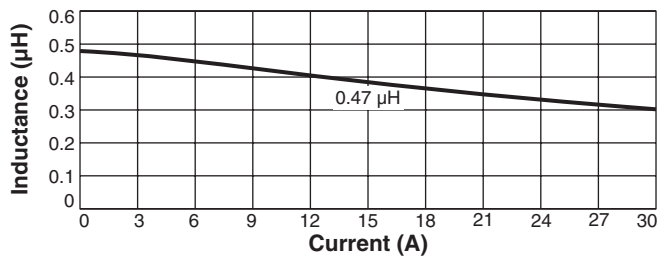
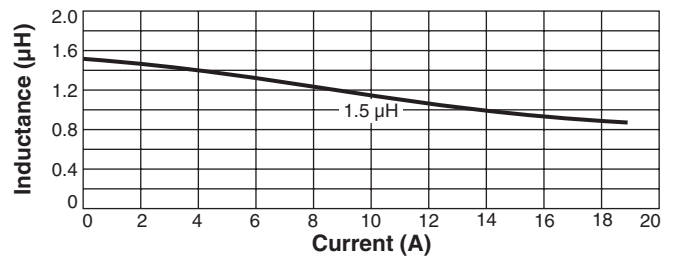
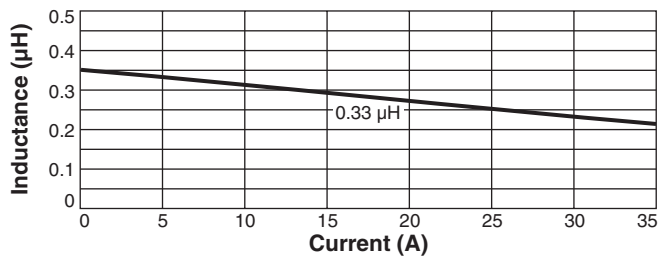
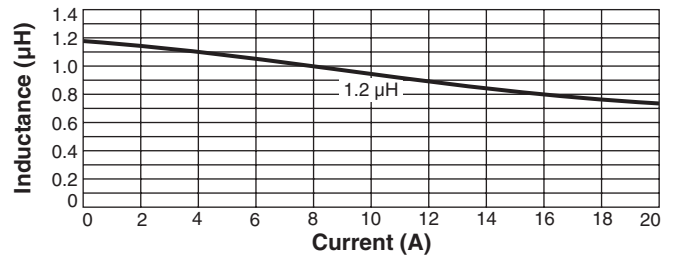
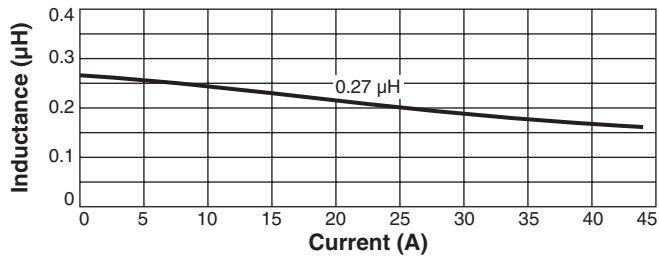
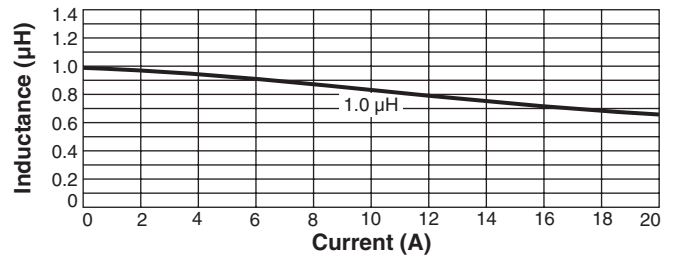
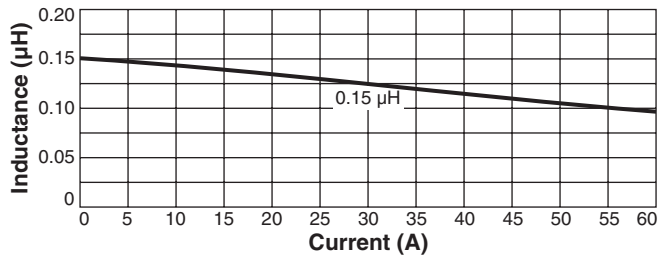

ML513PYA Series (7020)

L vs Frequency

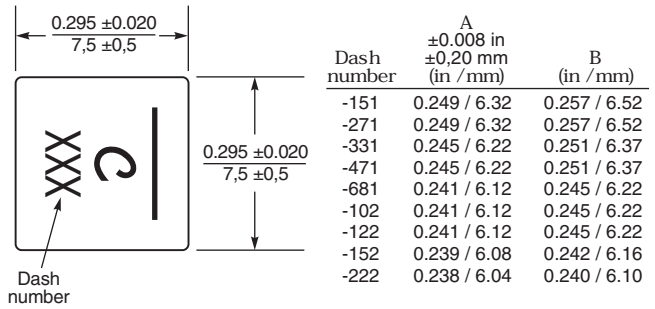
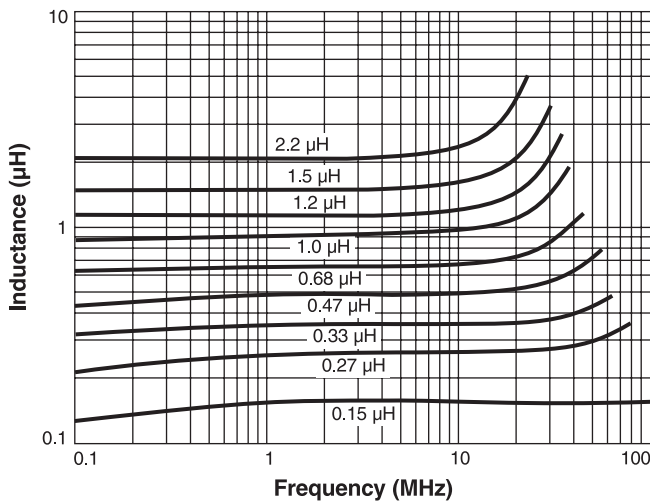

*Maximum height for -151 and -271 is 0.081 in / 2.05 mm.

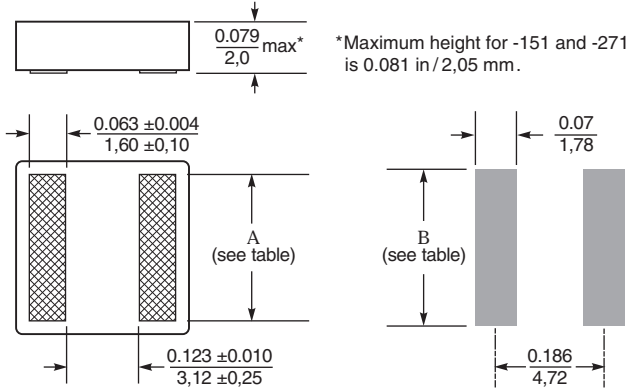

Dimensions are in $\frac{\text{inches}}{\text{mm}}$

Suggested Land Pattern

Irms Derating

