

Mil-Spec Connectors & Accessories



DEUTSCH ECD

Defense / Aerospace Operations . . .

is the world's premier manufacturer of electrical interconnection devices for use in defense, aerospace, and commercial applications. Whether you need an interconnection device for a commercial or military aircraft, missile, tank, truck transmission or a host of other applications, Deutsch has the solution you're looking for.

Deutsch ECD Defense Aerospace Operations

5733 W. Whittier Ave., Hemet CA (USA) 92545
Phone 909/765-2200 • FAX 909/922-1544

ABC Connectors

Composite Rectangular Interconnection System

ABC Module Arrangements

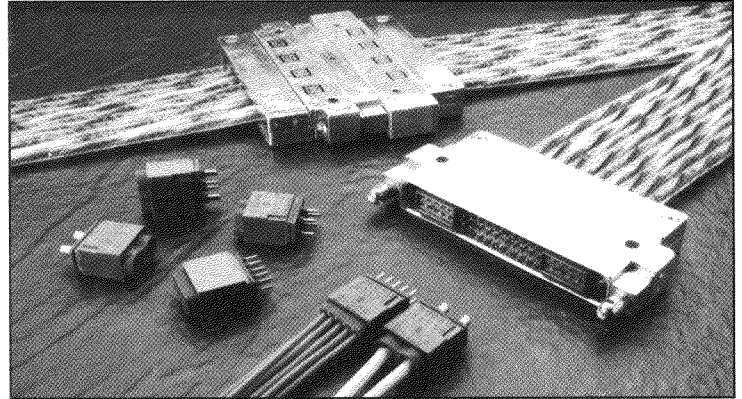

ABC modules are available in a variety of arrangements, using sizes 22, 20, 16 and 12 crimp-type contacts. You can use any combination of modules within the same shell, thus customizing the connector for your specific application.

Each module holds the contacts into place with a unique contact retention system. For environmental protection, a silicone rear grommet with a triad wire seal and a cork-in-a-bottle interfacial seal are featured.

Extended life contacts

The ABC system uses solderless, rear-release, crimp-type MIL-C-39029 contacts. They save time and reduce costs during assembly by eliminating the need for heat guns, wet processes and other special tools. And they keep field repair procedures quick and simple. They also last longer than other contacts. Thanks to a high-lubricity coating process called Deutschcoat V, each ABC connector has a 1,500 cycle durability rating – three times that of standard MIL-spec contacts.

HALF-INCH MODULES

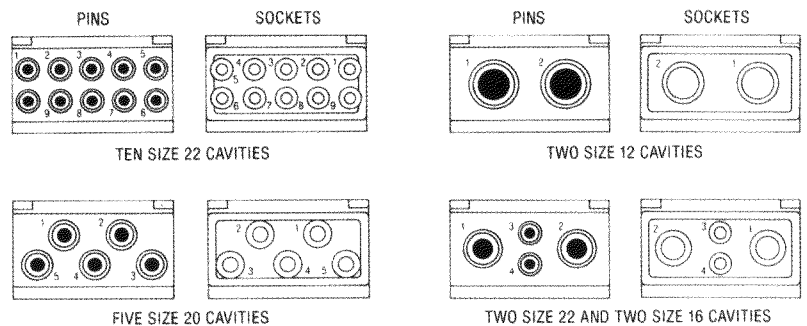

ONE-INCH MODULES

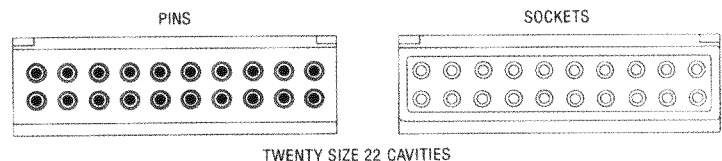

TWO-INCH MODULES

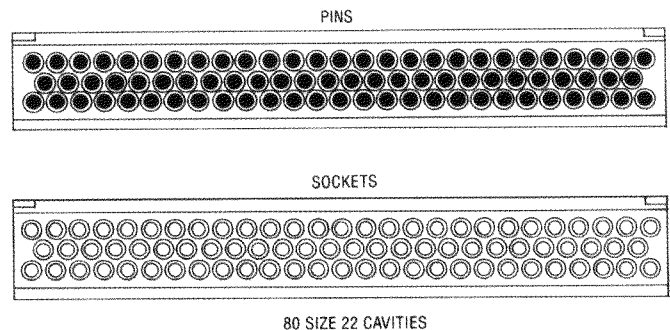

With The ABC System, there are over 4,000 combinations of modules and shells. Pictured are a few of the many

possibilities. With so many choices you can design a system that's exactly right for your needs.

ONE INCH MULTIPLE MODULE ARRANGEMENTS EXAMPLES

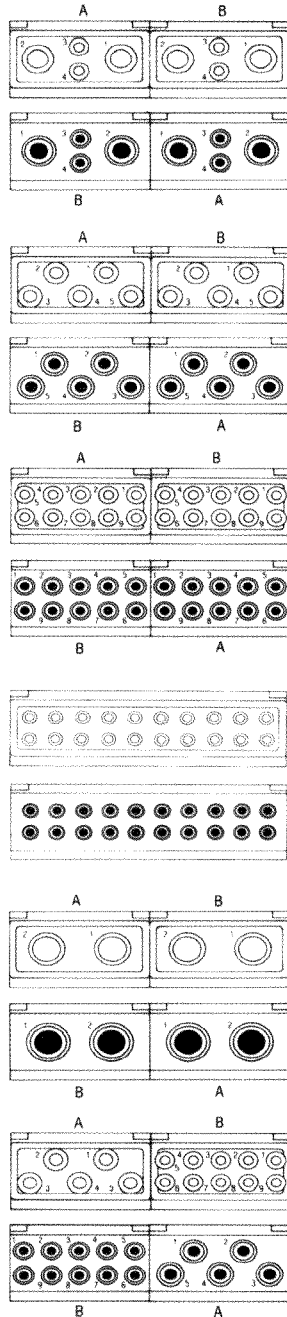

TWO INCH MULTIPLE MODULE ARRANGEMENTS EXAMPLES

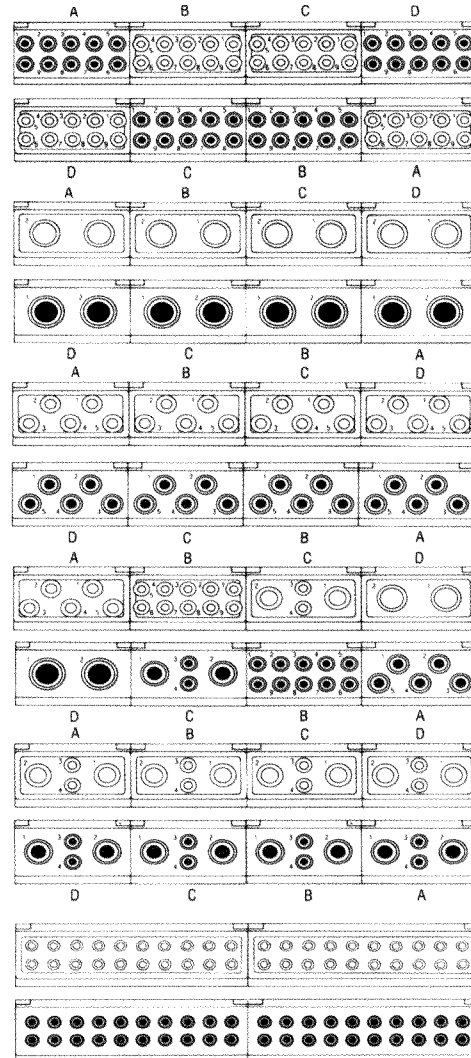

TWO INCH SINGLE MODULE ARRANGEMENT (80 PIN)

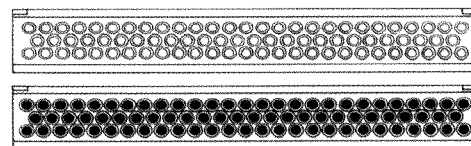

Single Module Configurations

HALF-INCH MODULES

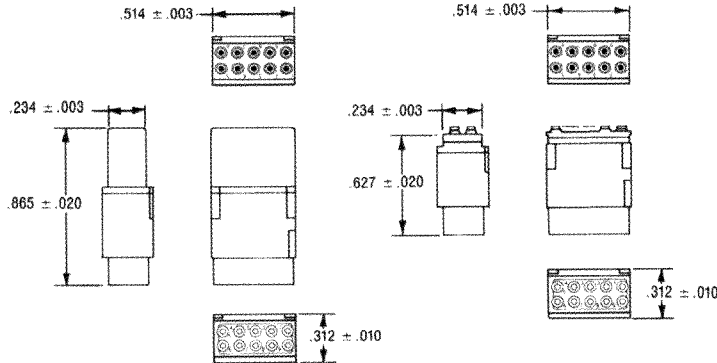

MODULE TYPE

DESIGNATOR	CONTACT SIZE
00	no cavities (Spacer)
22	22
20	20
16	16, 22
12	12

ORDERING INFORMATION DEUTSCH 1/2" MODULE — PART NUMBER

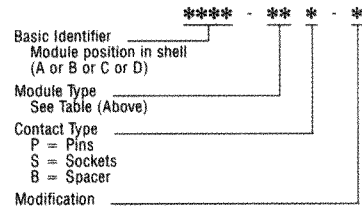

ONE-INCH MODULES (20 PIN)

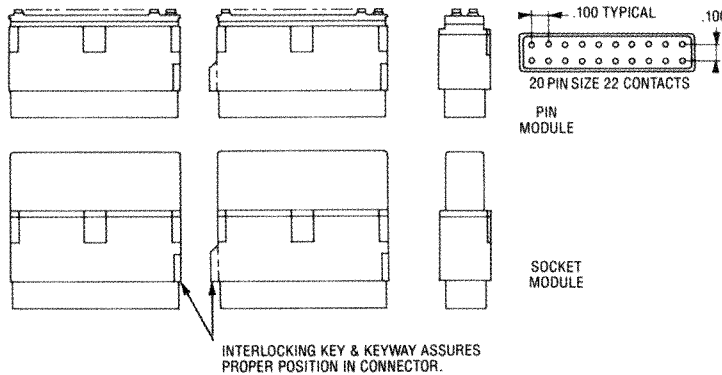

ORDERING INFORMATION DEUTSCH 1" MODULE — PART NUMBER

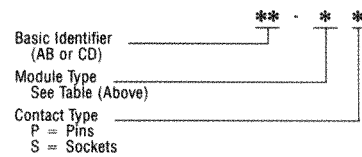

TWO-INCH MODULES (80 PIN)

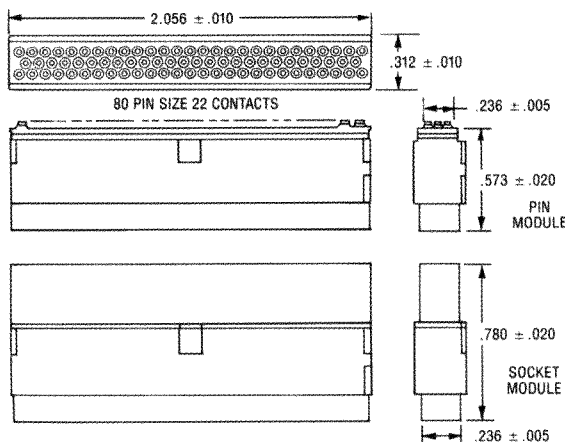

ORDERING INFORMATION 80 PIN MODULE — PART NUMBER

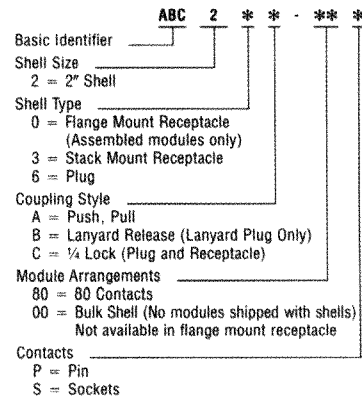

Ordering Contacts & Tooling

ORDERING CONTACTS & TOOLING

Size	Contact Deutsch Part No.	Style	Wire Gauge	Crimp Tool (Positioner)	Military Insertion/Extraction Tools	Sealing Plugs Deutsch Part No.	Strip Length ± .003	Color Code
22D	12331-22	Pin	22 thru 28	M22520/2-01			160-190	Green
22D	12336-22	Socket	22 thru 28	(M22520/2-09)	M81969/14-01	81539-23	160-190	Green
20	12331-20	Pin	20 thru 24	M22520/1-01			230-260	Red
20	12336-20	Socket	20 thru 24	(M22520/1-04)	M81969/14-02	4113-4-2001	230-260	Red
16	12331-16	Pin	20 thru 16	M22520/1-01			230-260	Blue
16	12336-16	Socket	20 thru 16	(M22520/1-04)	M81969/14-03	0613-1-1601	230-260	Blue
12	12331-12	Pin	20 thru 16	M22520/1-01			230-260	Yellow
12	12336-12	Socket	20 thru 16	(M22520/1-04)	M81969/14-04	0613-1-1201	230-260	Yellow

**FIGURE 4A CONTACT, SOCKET
22 GAGE SUBMINIATURE,
REAR INSERTION & REMOVAL**

2803-4-0000

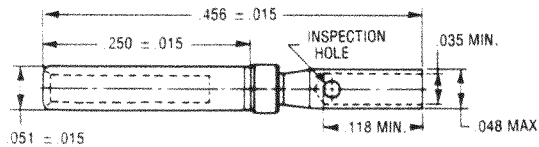

WIRE GAUGE RANGE	CRIMP TOOL	INSERTION AND REMOVAL TOOL
22 THRU 26	DANIELS MH800-K127	M15570-22-1

WIRE INSULATION O.D.	STRIP LENGTH
.039" TO .054"	5/32" TO 3/16"
.033" TO .038"	1/8"

**FIGURE 4B CONTACT, PIN
22 GAGE SUBMINIATURE,
REAR INSERTION & REMOVAL**

2841-5-9000

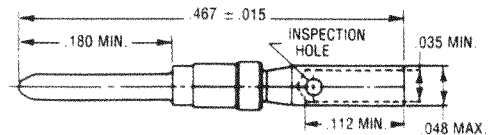

WIRE GAUGE RANGE	CRIMP TOOL	INSERTION AND REMOVAL TOOL
22 THRU 26	DANIELS MH800-K127	M15570-22-1

WIRE INSULATION O.D.	STRIP LENGTH
.039" TO .054"	5/32" TO 3/16"
.033" TO .038"	1/8"

**FIGURE 7A CONTACT, SOCKET
26 THRU 30 GAGE WIRE
SIZE 22 SUBMINIATURE
REAR INSERTION & REMOVAL**

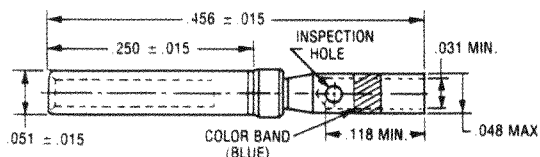

WIRE GAUGE RANGE	CRIMP TOOL	INSERTION AND REMOVAL TOOL
26 THRU 30	DANIELS MH800-K127	M15570-22-1

WIRE INSULATION O.D.	STRIP LENGTH
.039" TO .054"	5/32" TO 3/16"
.033" TO .038"	1/8"

**FIGURE 7B CONTACT, PIN
26 THRU 30 GAGE WIRE
SIZE 22 SUBMINIATURE
REAR INSERTION & REMOVAL**

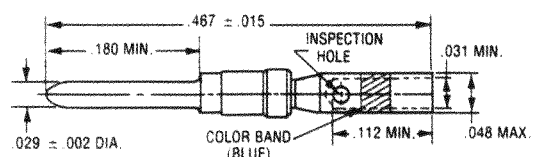

WIRE GAUGE RANGE	CRIMP TOOL	INSERTION AND REMOVAL TOOL
26 THRU 30	DANIELS MH800-K127	M15570-22-1

WIRE INSULATION O.D.	STRIP LENGTH
.039" TO .054"	5/32" TO 3/16"
.033" TO .038"	1/8"



Ordering Information

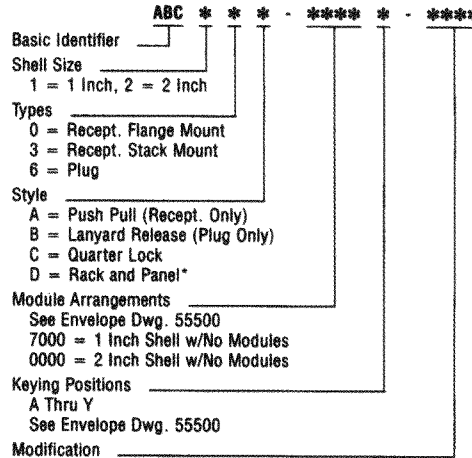

ABC 1" PLUG QUARTER LOCK

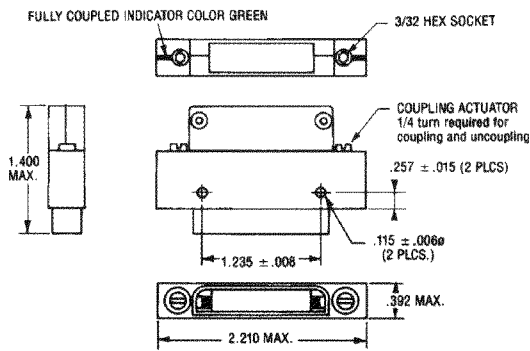

ABC 2" PLUG QUARTER LOCK

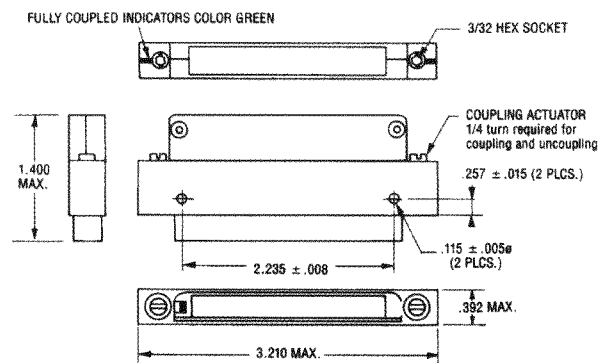

ABC 1" FLANGE MOUNT RECEPTACLE QUARTER LOCK

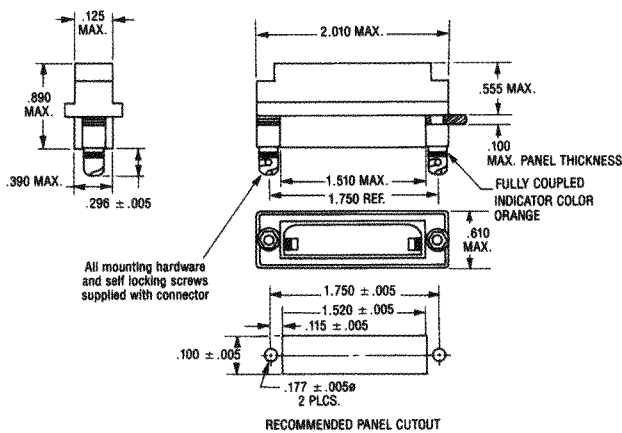

ABC 2" FLANGE MOUNT RECEPTACLE QUARTER LOCK

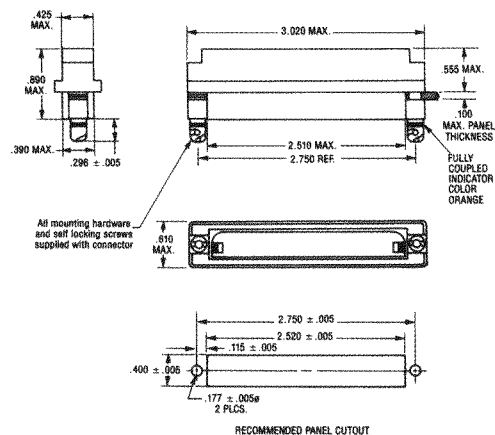

**ABC 1" RECEPTACLE
QUARTER LOCK**

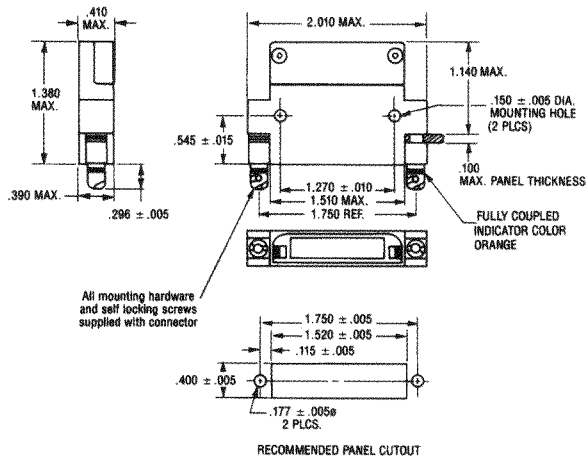

**ABC 2" RECEPTACLE
QUARTER LOCK**

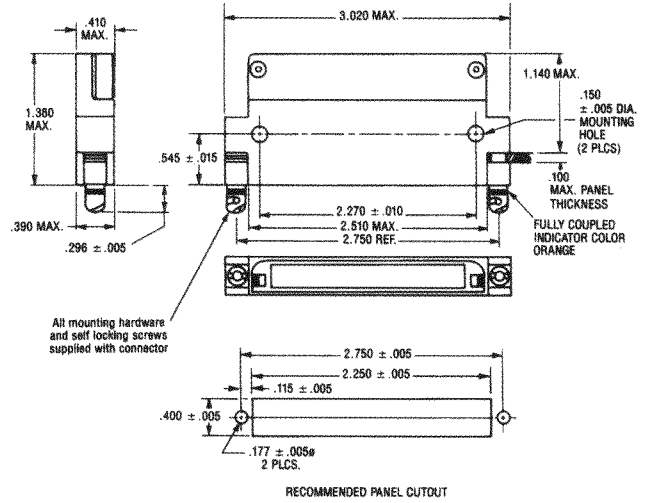

ABC 1" RECEPTACLE STACK MOUNTING

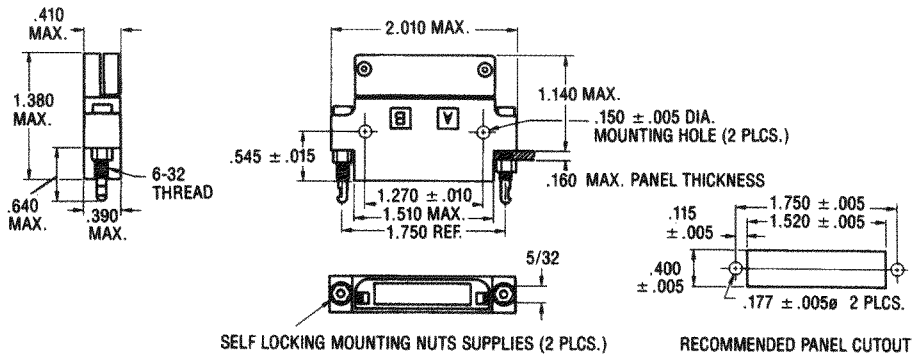

ABC 2" RECEPTACLE STACK MOUNTING

