

April 1997-4

Surface Mount and DIP Pressure Sensors *Low-cost packaged die*

DESCRIPTION

EXAR provides its two most popular pressure sensor die in surface mount and 6-pin dual in-line package (DIP) configurations. All parts in these series are uncompensated high-performance die mounted on a substrate with a plastic cap and either pins for through-board assembly or pads for surface mounting.

Both package types provide a low-cost way for OEM manufacturers to incorporate pressure sensors at costs close to raw die prices, without the need to handle, attach, or wire bond silicon sensor die.

Options include pressure range, surface mount or DIP mounting, absolute or gage configuration, and a choice of cap configurations. The result is a versatile product line suitable for a wide range of OEM applications.

The low-pressure series (models SM-5350 and SM-5450) incorporate EXAR's unique low-pressure die to achieve high performance in pressure ranges down to 0.15 psi full-scale.

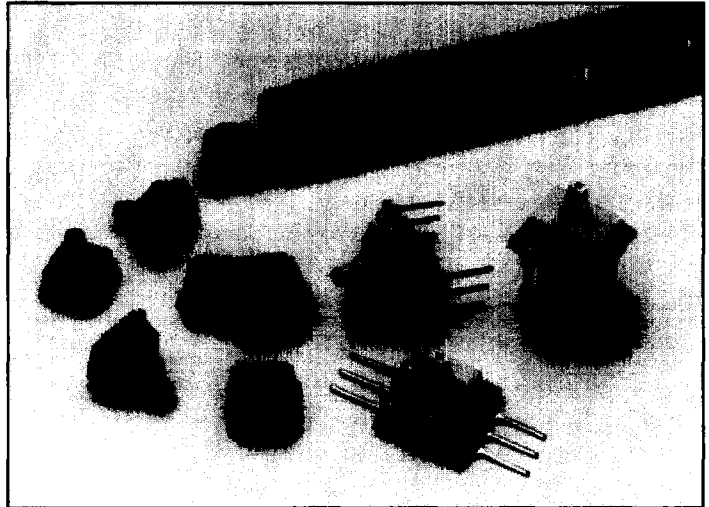

FEATURES

- Low Cost
- Easy to Use
- 0.15 to 100 psi Full-scale Ranges Available
- Compact and Light-weight
- High-performance, Stable Silicon Chip and Package
- Easily Embedded in OEM Equipment
- Molded Pressure Port Option for Attachment to 1/8 Inch Tubing
- High-volume

APPLICATIONS

- Altimeters
- Barometric Correction
- Tire Gauges
- Digital Pressure Gauges
- Environmental Monitoring
- Appliances
- Consumer and Sports
- HVAC
- Medical Instrumentation and Monitoring
- Pressure Differential and Flow Monitoring
- Hand-held Gauges

SM-5310/5350

SM-5410/5450



SELECTION

Model SM-5310 **Standard Pressure Range, Surface Mount**

For general purpose applications, the SM-5310 series has the smallest footprint and covers the range from 5 psi to 100 psi full scale.

The top cap is available with either a molded port for attaching 1/8 inch plastic tubing or with a hole. The cap with hole provides a low profile for measuring barometric pressure, measuring pressure in the electronics enclosure or "O" ring sealing to another surface.

It is also available in both absolute and gage configurations. In absolute configuration, the pressure is applied to the top of the sensor (through either the molded port or the hole in the cap). A reference vacuum chamber is formed in the die during manufacturing.

In gage configuration, pressure is applied to the top cap (either through plastic tubing over the molded port or an "O" ring seal to the cap) and the gage reference pressure is applied through a hole in the bottom of the substrate. The mating board must be designed to leave a clear path to this hole for accurate gage measurements.

Model SM-5350 **Low Pressure Range, Surface Mount**

The model SM-5350 uses EXAR's unique low-pressure die, which is a true low-pressure structure (not just a *derated standard die*). As a result, it has very good stability, linearity and dynamic range down to 0.15 psi full scale.

This die is larger than the standard pressure die and therefore the footprint is larger than the model SM-5310. It uses the same substrate as the models SM-5410 and SM-5450.

It is also available with the option of a molded port for tubing or a cap with hole.

Low-pressure parts are typically used in gage configuration, and the model SM-5350 is only available as a gage part.

Model SM-5410 **Standard Pressure Range, Dual In-line Pins (DIP)**

The model SM-5410 DIP configuration is similar to the model SM-5310 surface mount except that it uses a slightly larger substrate to accommodate six pins for through-board printed circuit mounting.

It is also available with or without a pressure port, and in absolute or gage configurations. It is available only with a ceramic substrate.

Models SM-5310 and SM-5410 are available in 5, 15, 30, 60, and 100 psi full scale ranges.

Model SM-5450 **Low Pressure Range Dual In-line Pins (Dip)**

The model SM-5450 is identical to the SM-5350 with the addition of six pins to allow through-board printed circuit mounting.

Models SM-5350 and SM-5450 are available in 0.15, 0.3, 0.8, 1.5, and 3.0 psi full scale ranges.

CHARACTERISTICS

All parameters measured at 5V excitation at room temperature, unless otherwise specified.

All Models

| Parameter | Min | Typ | Max | Units |
|-----------------------------|-----|---------|------|-------------------|
| Excitation Voltage | 0 | 5.0 | 10.0 | V |
| Excitation Current | 0 | 1.5 | 3.0 | mA |
| Offset | -50 | 0 | 50 | mV |
| TC Span ¹ | | -21 ± 5 | | %FS/100°C |
| TC Resistance | | 27 ± 5 | | %/100°C |
| Bridge Impedance | 2.7 | 3.3 | 4.0 | kΩ |
| Burst Pressure ² | 5X | | | Rated FS Pressure |
| Operating Temp | -40 | | 85 | °C |
| Storage Temp | -55 | | 125 | °C |

SM-5310 and SM-5410 Standard Pressure Series Only

| Span (FS Range) | Min | Typ | Max | Units |
|------------------------|------|-------|------|-----------|
| 5 psi | 75 | 100 | 125 | mV |
| 15 psi | 105 | 145 | 175 | mV |
| 30 psi | 115 | 165 | 195 | mV |
| 60 psi | 115 | 180 | 220 | mV |
| 100 psi | 115 | 200 | 250 | mV |
| Linearity ⁴ | -0.3 | ±0.05 | +0.3 | %FS |
| TC Offset ¹ | | ±7 | | %FS/100°C |

SM-5350 and SM-5450 Low Pressure Series Only

| Span (FS Range) | Min | Typ | Max | Units |
|------------------------|------|------|------|-----------|
| 0.15 psi | 25 | 50 | 75 | mV |
| 0.3 psi | 25 | 50 | 75 | mV |
| 0.8 psi | 25 | 50 | 75 | mV |
| 1.5 psi | 25 | 50 | 75 | mV |
| 3.0 psi | 25 | 50 | 75 | mV |
| Linearity ⁴ | -0.3 | ±0.1 | +0.3 | %FS |
| TC Offset ¹ | | ±12 | | %FS/100°C |

Notes

¹ Measured from 0 to 70°C.

² Sensor die will survive pressure specified for all ranges. Maximum package pressure is 225 psi.

³ Measured at 5V, constant voltage excitation.

⁴ Best fit straight line (BFSL); for 0.3 psi full-scale, linearity is ±0.5%FS. For 0.15 psi full-scale, linearity is ±1.0%FS.

SM-5310/5350 SM-5410/5450



DEVICE PINOUTS

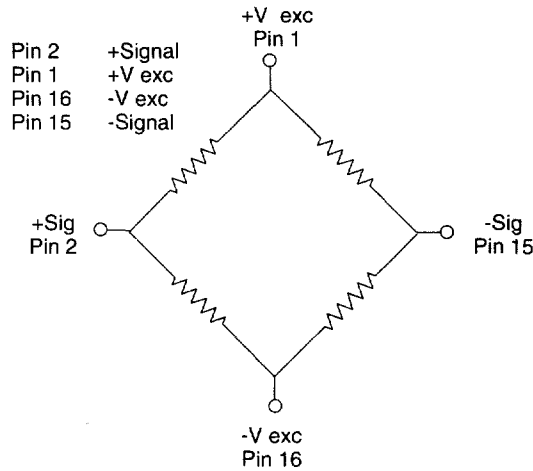

Note
Model SM-5310 is a closed bridge device.

Figure 1. Model SM-5310

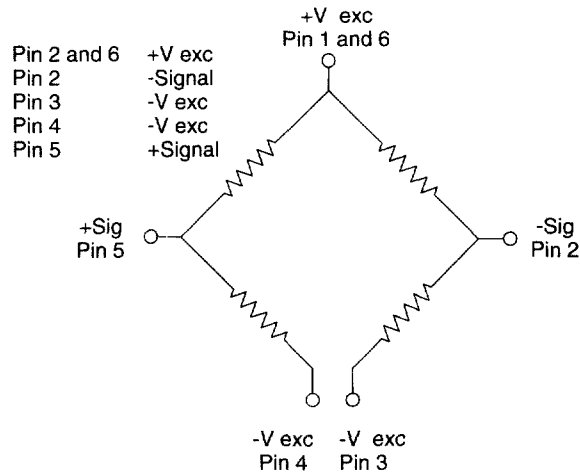

Note
Models SM-5350, SM-5410 and SM-5450 are open bridge devices: pins 1 and 6 are connected internally (only one needs to be connected to +V exc). Pins 3 and 4 must both be connected to a -V exc supply.

Figure 2. Model SM-5350, SM-5410, and SM-5450

DIMENSIONS

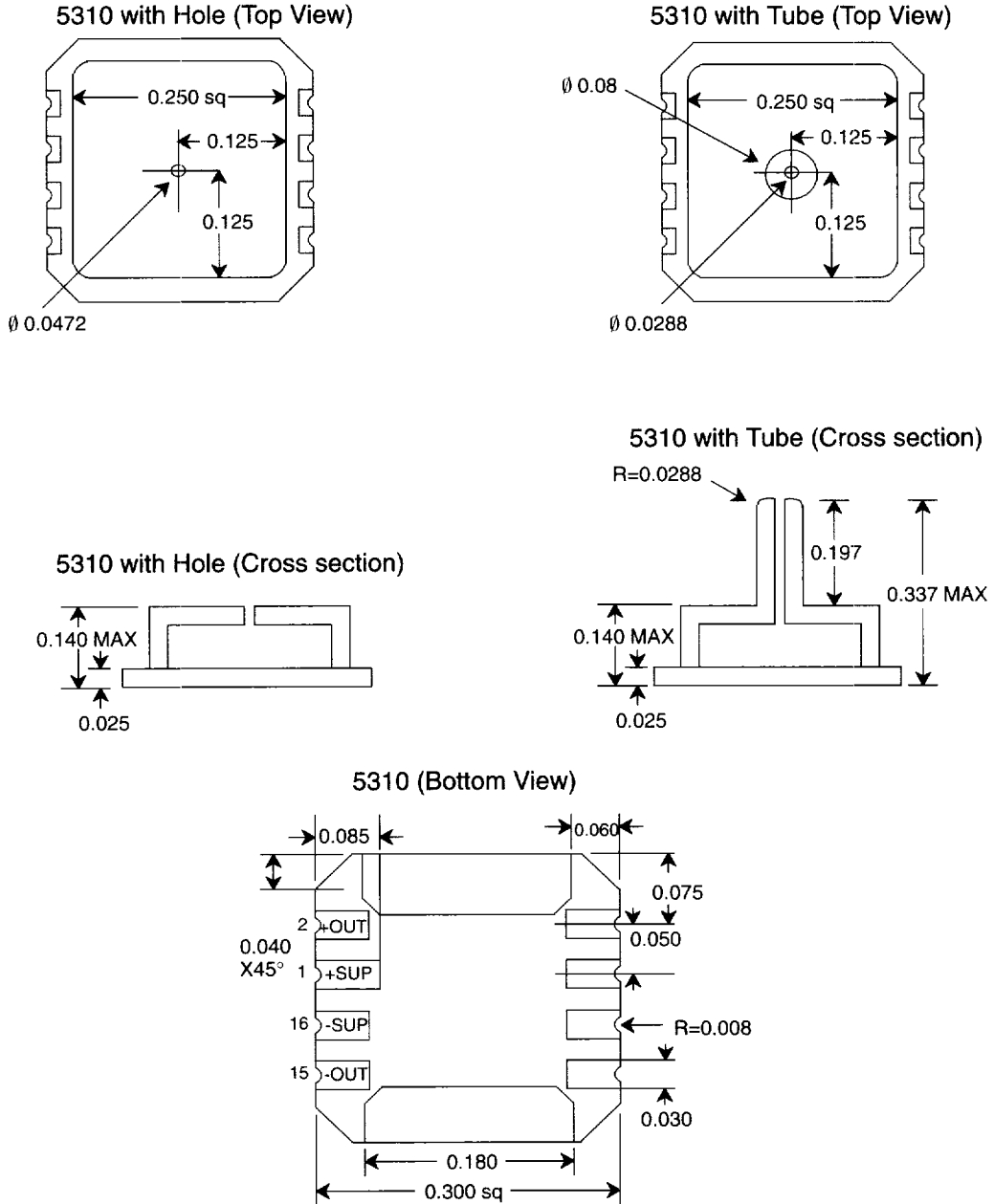
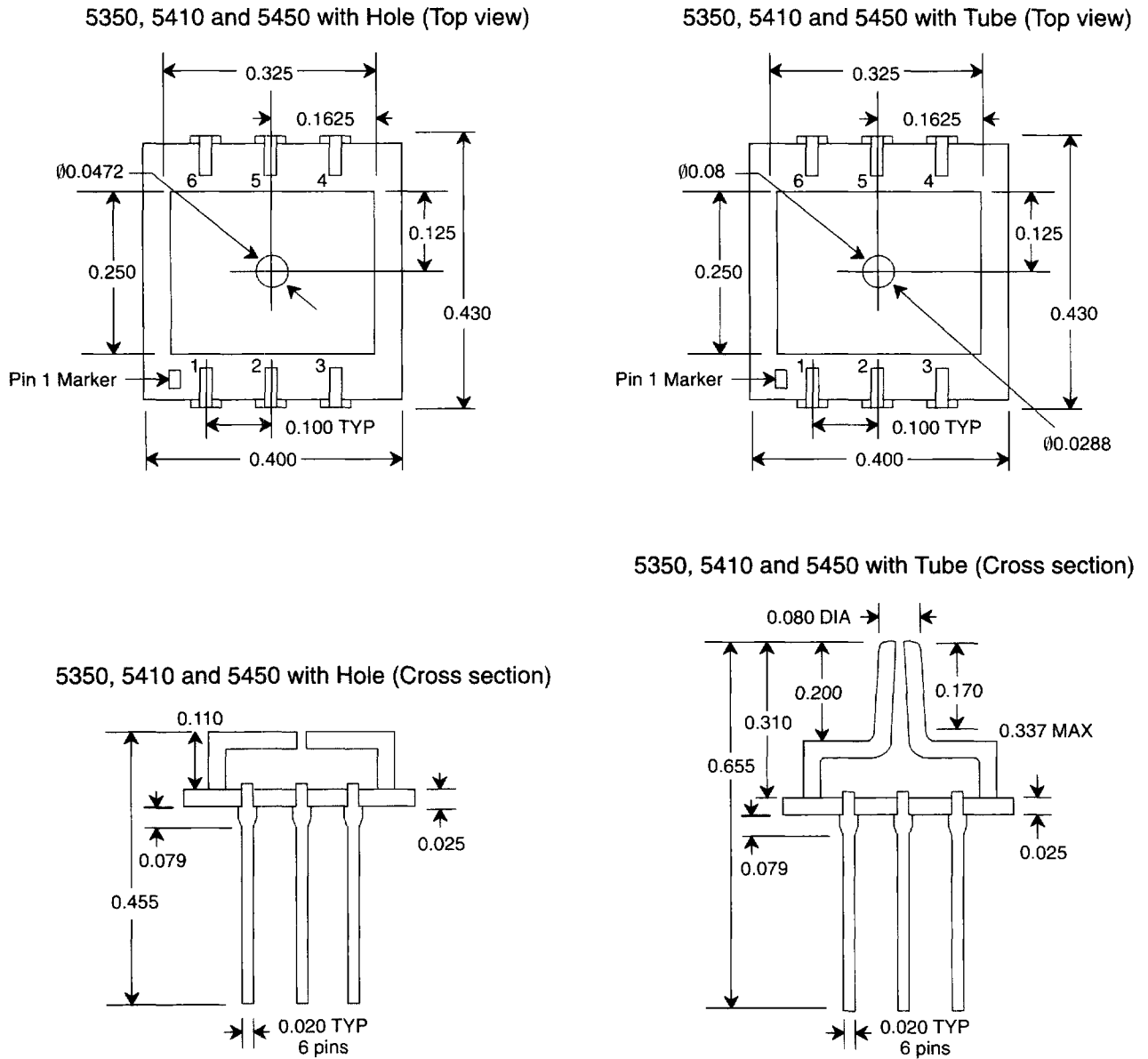

Figure 3. Model SM-5310

Note
 All dimensions are shown in inches.

SM-5310/5350 SM-5410/5450



Notes

- 1) Nominal dimensions in inches.
- 2) Tube tapers from 0.080 DIA to 0.100 DIA at 0.170 from top of tube.
- 3) SM-5350 pins are out in the plane of the substrate.
- 4) Maximum temperature for surface mount during mounting is 220° C for one minute, solder composition is 63% tin and 37% lead.
- 5) Maximum temperature for DIP is 250° C for five seconds maximum.

Figure 4. Models SM-5350, SM-5410 and SM-5450

ORDERING INFORMATION

Pressure Type: Models SM-5310 and SM-5410

A: Absolute
G: Gage

Cap Type

P: Port (tube)
H: Hole

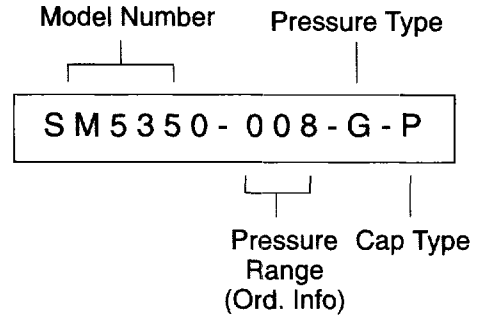

Pressure Range

Standard Pressure
Models SM-5310 (SMT) and SM-5410 (DIP)

| Ord. Info | psi | BAR | kPa | mmHg | in H ₂ O | mmH ₂ O |
|-----------|-----|-------|--------|--------|---------------------|--------------------|
| 005 | 5 | 0.345 | 34.47 | 258.6 | 138.4 | 3515.4 |
| 015 | 15 | 1.034 | 103.42 | 775.7 | 415.2 | 10546.1 |
| 030 | 30 | 2.068 | 206.84 | 1551.5 | 830.4 | 21092.2 |
| 060 | 60 | 4.137 | 413.68 | 3102.9 | 1660.8 | 42184.3 |
| 100 | 100 | 6.895 | 689.47 | 5171.5 | 2768 | 70307.2 |

Low Pressure
Models SM-5350 (SMT) and SM-5450 (DIP)

| Ord. Info | psi | BAR | kPa | mmHg | in H ₂ O | mmH ₂ O |
|-----------|------|-------|-------|-------|---------------------|--------------------|
| 001 | 0.15 | 0.010 | 1.03 | 7.8 | 4.152 | 105.5 |
| 003 | 0.3 | 0.021 | 2.07 | 15.5 | 8.304 | 210.9 |
| 008 | 0.8 | 0.055 | 5.52 | 41.4 | 22.144 | 562.5 |
| 015 | 1.5 | 0.103 | 10.34 | 77.6 | 41.52 | 1024.6 |
| 030 | 3.0 | 0.207 | 20.68 | 155.1 | 83.04 | 2109.2 |

Special Configurations are available. Contact EXAR Corporation for more information.

NOTICE

EXAR Corporation reserves the right to make changes to the products contained in this publication in order to improve design, performance or reliability. EXAR Corporation assumes no responsibility for the use of any circuits described herein, conveys no license under any patent or other right, and makes no representation that the circuits are free of patent infringement. Charts and schedules contained herein are only for illustration purposes and may vary depending upon a user's specific application. While the information in this publication has been carefully checked; no responsibility, however, is assumed for inaccuracies.

EXAR Corporation does not recommend the use of any of its products in life support applications where the failure or malfunction of the product can reasonably be expected to cause failure of the life support system or to significantly affect its safety or effectiveness. Products are not authorized for use in such applications unless EXAR Corporation receives, in writing, assurances to its satisfaction that: (a) the risk of injury or damage has been minimized; (b) the user assumes all such risks; (c) potential liability of EXAR Corporation is adequately protected under the circumstances.

Copyright 1993 EXAR Corporation Silicon Microstructures Division
Datasheet April 1997

Reproduction, in part or whole, without the prior written consent of EXAR Corporation is prohibited.