

2.5 x 2.0 x 1.2mm BUILT-IN CAPACITANCE CERAMIC RESONATOR



2.5 x 2.0 x 1.2mm

AWSCR-CW

Pb in ceramic
(exempt per RoHS 2002/95/EC Annex (7))

RoHS
Compliant

FEATURES:

- Low resonant impedance
- Built-in load capacitors
- IR reflow capable

APPLICATIONS:

- Remote controls, Microprocessor clocks, Mobile phones, DVD & CD-Roms, Electric appliances, Industrial controllers
- Consumer electronics

STANDARD SPECIFICATIONS:

Item	Requirement
Frequency Range	20.00MHz to 48.00 MHz
Resonant Impedance	See Table 2.1
Frequency Tolerance	± 0.5% (at 25°C)
Frequency stability	±0.2% (-25°C~+85°C) max*
Withstanding Voltage (V)	50 (DC , 1 min)
Rating Voltage	
(1) D.C. Voltage	6 V DC max
(2) A.C. Voltage	15 Vp-p. max
Load Capacitance	5pF± 20% (C1=C2)
Insulation Resistance	100MΩ min. (10V, 1min)
Operating Temperature	-25°C to +85°C*
Storage Temperature	-55°C to +85°C
Aging Rate (Fosc)	±0.2% max. (From initial value)

Table 2.1

Frequency range (MHz)	Resonant Impedance (Ro)(Ω) max
20.00 MHz - 25.99 MHz	60
26.00 MHz - 35.00 MHz	50
35.01 MHz - 48.00 MHz	50

* Please contact ABRACON for tighter stability and/or wider temperature range

TEST CIRCUIT:

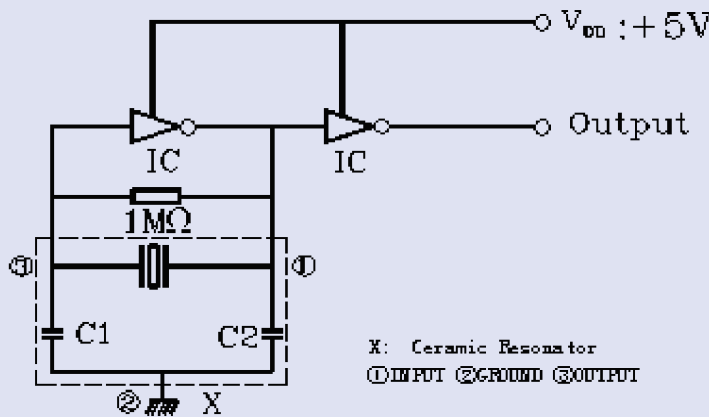

OPTIONS AND PART IDENTIFICATION:

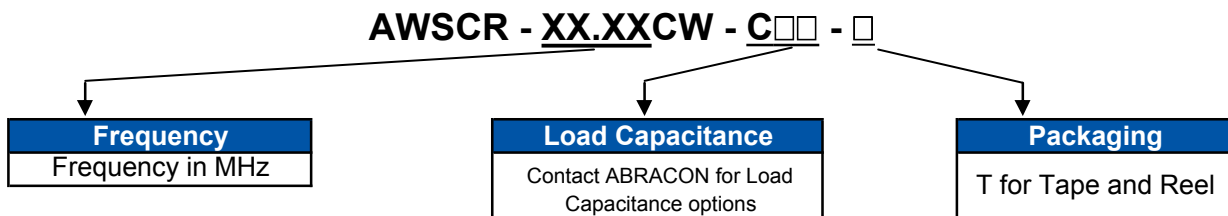

2.5 x 2.0 x 1.2mm BUILT-IN CAPACITANCE CERAMIC RESONATOR



2.5 x 2.0 x 1.2mm

AWSCR-CW

Pb in ceramic
(exempt per RoHS 2002/95/EC Annex (7))

**RoHS
Compliant**

OUTLINE DRAWING:

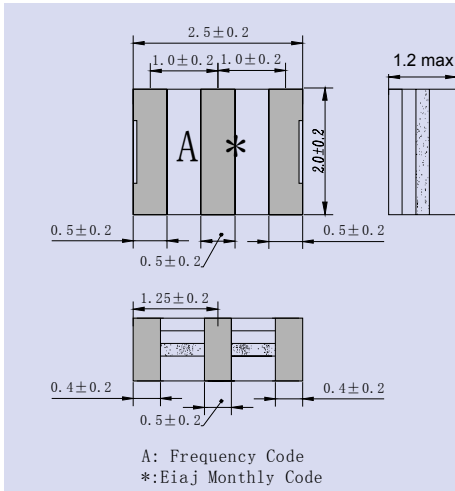

RECOMMENDED LAND PATTERN

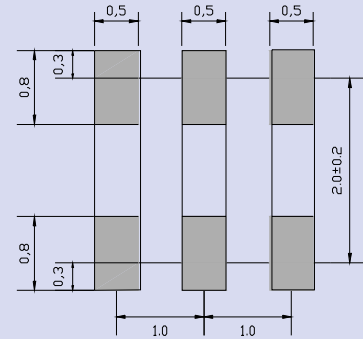

Dimension : mm

TAPE & REEL: [3,000pcs/reel]

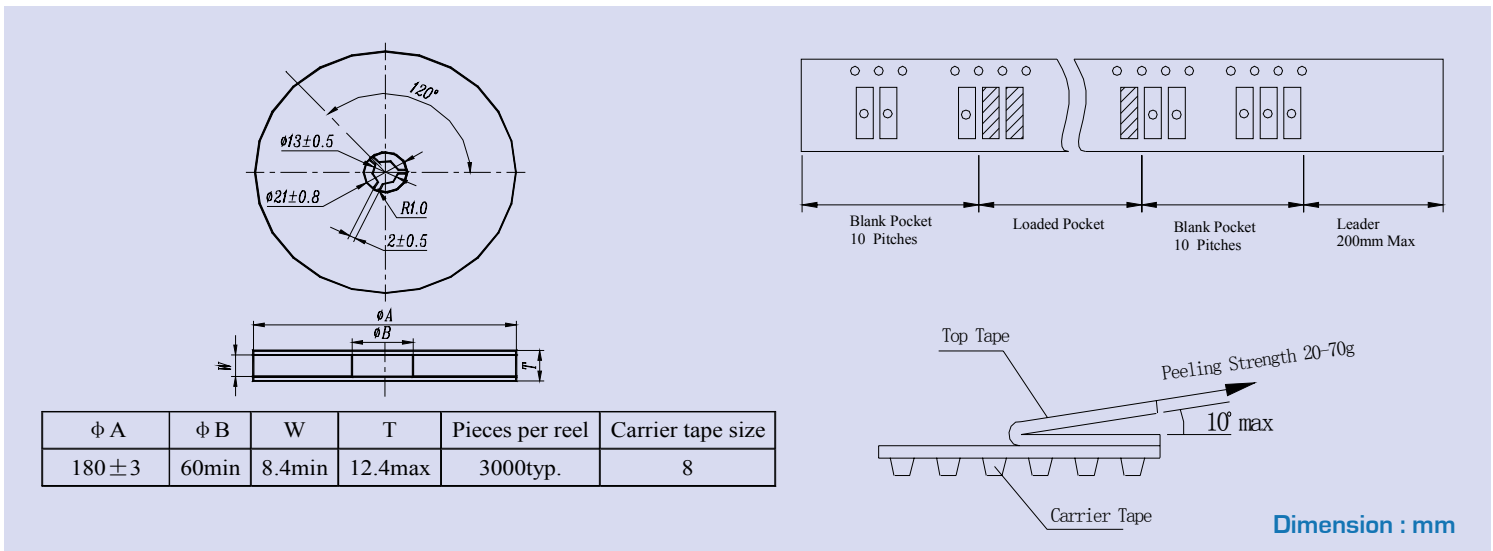

Dimension : mm

CAUTION

- Do not apply excess mechanical stress to the component body or terminations. Do not attempt to re-form or bend the components as this will cause damage to the component.
- This component is not hermetically sealed. Do not clean or wash the component.
- Reflow soldering: Do not use strong acidity flux, such as flux with chlorine content of greater than 0.2wt% during reflow Soldering.
- Do not expose the component to open flame.
- This specification applies to the functionality of the component as a single unit. Customers are advised to insure that the component is thoroughly evaluated in the particular application.
- Shelf life: The warranted shelf life of this product is six months after the delivery date under the conditions of sealed, unopened, original packaging.
- Storage conditions: If the product is to be stored for a period greater than six months after the delivery date, it is recommended that customers confirm the solderability and characteristics for the product prior to use.
- This product is not recommended for use in the following applications: Automotive, Medical, Military, Safety, or any other high-reliability, life-dependant application. Contact Abracon Corporation prior to using this product when in doubt.