

10 mm (0.40 inch) Seven Segment Displays

Technical Data

HDSP-F00X Series
HDSP-F15X Series
HDSP-F20X Series
HDSP-F30X Series
HDSP-F40X Series
HDSP-F50X Series
HDSP-G00X Series
HDSP-G15X Series
HDSP-G20X Series
HDSP-G30X Series
HDSP-G40X Series
HDSP-G50X Series

Features

- **Industry Standard Size**
- **Industry Standard Pinout**
7.6 mm (0.3 inch) DIP Single
15.24 mm (0.6 inch) DIP Dual
Leads on 2.54 mm (0.1 inch) Centers
- **Choice of Colors**
Red, AlGaAs Red, High Efficiency Red, Orange, Yellow, Green
- **Excellent Appearance**
Evenly Lighted Segments
Mitered Corners on Segments
Gray Package Gives Optimum Contrast
±50° Viewing Angle
- **Design Flexibility**
Common Anode or Common Cathode
Single and Dual Digits
Right Hand Decimal Point
±1. Overflow Character
- **Categorized for Luminous Intensity**
Yellow and Green Categorized for Color
Use of Like Categories Yields a Uniform Display
- **High Light Output**
- **High Peak Current**
- **Excellent for Long Digit String Multiplexing**



- **Intensity and Color Selection Option**
- **Sunlight Viewable AlGaAs**

Devices

| Red HDSP. | AlGaAs Red ⁽¹⁾ HDSP. | HER HDSP. | Orange HDSP. | Yellow HDSP. | Green HDSP. | Description | Package Drawing |
|-----------|---------------------------------|-----------|--------------|--------------|-------------|---|-----------------|
| F001 | F151 | F201 | F401 | F301 | F501 | Common Anode Right Hand Decimal | A |
| F003 | F153 | F203 | F403 | F303 | F503 | Common Cathode Right Hand Decimal | B |
| F007 | F157 | F207 | F407 | F307 | F507 | Common Anode ±1. Overflow | C |
| F008 | F158 | F208 | F408 | F308 | F508 | Common Cathode ±1. Overflow | D |
| G001 | G151 | G201 | G401 | G301 | G501 | Two Digit Common Anode Right Hand Decimal | E |
| G003 | G153 | G203 | G403 | G303 | G503 | Two Digit Common Cathode Right Hand Decimal | F |

Note:

1. These displays are recommended for high ambient light operation. Please refer to the HDSP-F10X data sheet for low current operation.

Description

The 10 mm (0.40 inch) LED seven segment displays are HP's most space-efficient character size. They are designed for viewing distances

up to 4.5 metres (15 feet). These devices use an industry standard size package and pinout. The dual numeric, single numeric, and ± 1 overflow devices feature a right hand

decimal point. All devices are available as either common anode or common cathode.

Typical applications include instruments, point of sale terminals, and appliances.

Package Dimensions

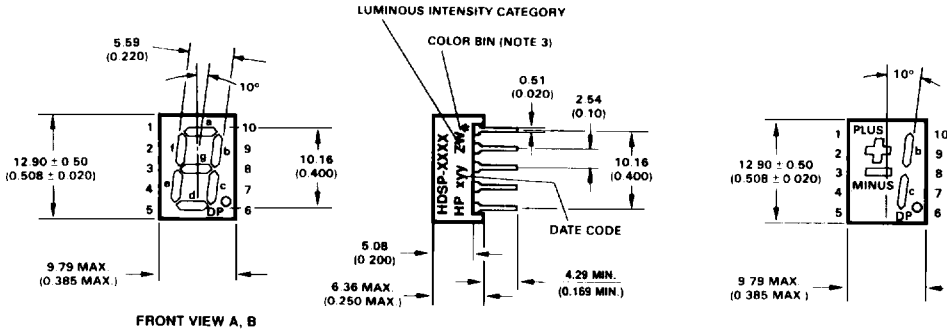

*The End View of package indicates Country of Origin.

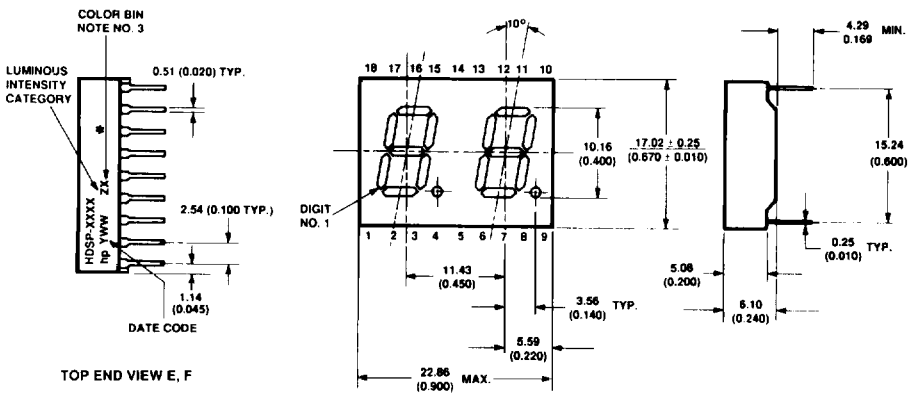
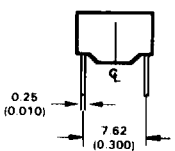

*The End View of package indicates Country of Origin.

- NOTES:
1. DIMENSIONS ARE IN MILLIMETRES (INCHES).
 2. ALL UNTOLERANCED DIMENSIONS ARE FOR REFERENCE ONLY.
 3. WHERE APPLICABLE.

SEVEN SEGMENT NUMERIC DISPLAYS

Internal Circuit Diagram

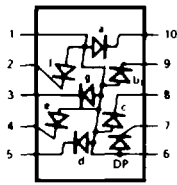

A

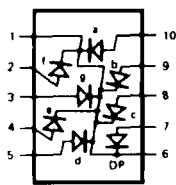

B

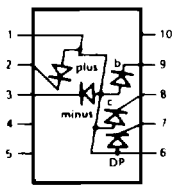

C

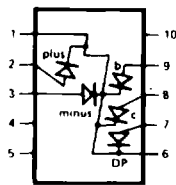

D

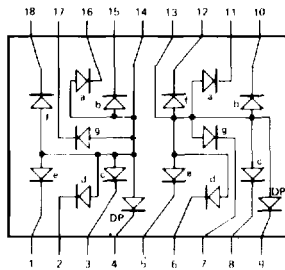

E

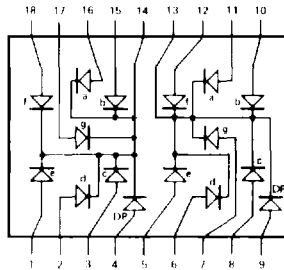

F

| PIN | FUNCTION | | | |
|-----|----------------------|------------------------|----------------------|------------------------|
| | A | B | C | D |
| 1 | ANODE ⁽¹⁾ | CATHODE ⁽²⁾ | ANODE ⁽¹⁾ | CATHODE ⁽²⁾ |
| 2 | CATHODE f | ANODE f | CATHODE PLUS | ANODE PLUS |
| 3 | CATHODE g | ANODE g | CATHODE MINUS | ANODE MINUS |
| 4 | CATHODE e | ANODE e | NC | NC |
| 5 | CATHODE d | ANODE d | NC | NC |
| 6 | ANODE ⁽¹⁾ | CATHODE ⁽²⁾ | ANODE ⁽¹⁾ | CATHODE ⁽²⁾ |
| 7 | CATHODE DP | ANODE DP | CATHODE DP | ANODE DP |
| 8 | CATHODE c | ANODE c | CATHODE c | ANODE c |
| 9 | CATHODE b | ANODE b | CATHODE b | ANODE b |
| 10 | CATHODE a | ANODE a | NC | NC |

NOTES:
 1. REDUNDANT ANODES
 2. REDUNDANT CATHODES

| PIN | FUNCTION | |
|-----|-------------------|----------------|
| | E | F |
| 1 | E CATHODE NO. 1 | E ANODE NO. 1 |
| 2 | D CATHODE NO. 1 | D ANODE NO. 1 |
| 3 | C CATHODE NO. 1 | C ANODE NO. 1 |
| 4 | DP CATHODE NO. 1 | DP ANODE NO. 1 |
| 5 | E CATHODE NO. 2 | E ANODE NO. 2 |
| 6 | D CATHODE NO. 2 | D ANODE NO. 2 |
| 7 | G CATHODE NO. 2 | G ANODE NO. 2 |
| 8 | C CATHODE NO. 2 | C ANODE NO. 2 |
| 9 | CP CATHODE NO. 2 | DP ANODE NO. 2 |
| 10 | B CATHODE NO. 2 | B ANODE NO. 2 |
| 11 | A CATHODE NO. 2 | A ANODE NO. 2 |
| 12 | F CATHODE NO. 2 | F ANODE NO. 2 |
| 13 | DIGIT NO. 2 ANODE | |
| 14 | DIGIT NO. 1 ANODE | |
| 15 | B CATHODE NO. 1 | B ANODE NO. 1 |
| 16 | A CATHODE NO. 1 | A ANODE NO. 1 |
| 17 | G CATHODE NO. 1 | G ANODE NO. 1 |
| 18 | F CATHODE NO. 1 | F ANODE NO. 1 |

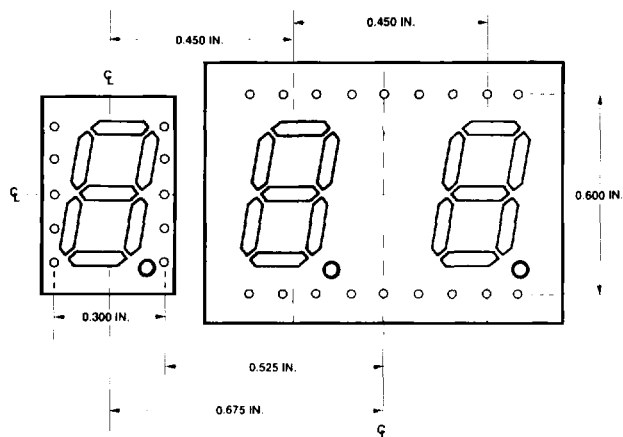

HOLE PATTERN FOR PCB LAYOUT TO ACHIEVE UNIFORM 0.450 IN. DIGIT TO DIGIT PITCH. FOR HDSP-FXXX TO HDSP-GXXX.

Absolute Maximum Ratings

| Description | Red HDSP-F00X/G00X Series | AlGaAs Red HDSP-F15X/G15X Series | HER/Orange HDSP-F20X/G20X/G40X Series | Yellow HDSP-F30X/G30X Series | Green HDSP-F50X/G50X Series | Units |
|--|---------------------------|----------------------------------|---------------------------------------|------------------------------|-----------------------------|-------|
| Average Power per Segment or DP | 82 | 96 | 105 | 80 | 105 | mW |
| Peak Forward Current per Segment or DP | 150 ⁽¹⁾ | 160 ⁽³⁾ | 90 ⁽⁷⁾ | 60 ⁽⁷⁾ | 90 ⁽⁹⁾ | mA |
| DC Forward Current per Segment or DP | 25 ⁽²⁾ | 40 ⁽⁴⁾ | 30 ⁽⁸⁾ | 20 ⁽⁸⁾ | 30 ⁽¹⁰⁾ | mA |
| Operating Temperature Range | -40 to +100 | -20 to +100 ⁽¹¹⁾ | -40 to +100 | | | °C |
| Storage Temperature Range | -55 to +100 | | | | | °C |
| Reverse Voltage per Segment or DP | 3.0 | | | | | V |
| Lead Solder Temperature for 3 Seconds (1.59 mm [0.63 in.] below seating plane) | 260 | | | | | °C |

Notes:

- See Figure 1 to establish pulsed conditions.
- Derate above 80°C at 0.63 mA/°C.
- See Figure 2 to establish pulsed conditions.
- Derate above 46°C at 0.54 mA/°C.
- See Figure 7 to establish pulsed conditions.
- Derate above 53°C at 0.45 mA/°C.
- See Figure 8 to establish pulsed conditions.
- Derate above 81°C at 0.52 mA/°C.
- See Figure 9 to establish pulsed conditions.
- Derate above 39°C at 0.37 mA/°C.
- For operation below -20°C, contact your local HP components sales office or an authorized distributor.

Electrical/Optical Characteristics at T_A = 25°C

Red

| Device Series | Parameter | Symbol | Min. | Typ. | Max. | Units | Test Conditions |
|----------------|--|---------------------|------|------|------|----------|-------------------------|
| HDSP-F00X/G00X | Luminous Intensity/Segment ^(1,2) (Digit Average) | I _v | 650 | 1200 | | μcd | I _F = 20 mA |
| | Forward Voltage/Segment or DP | V _F | | 1.6 | 2.0 | V | I _F = 20 mA |
| | Peak Wavelength | λ _{PEAK} | | 655 | | nm | |
| | Dominant Wavelength ⁽³⁾ | λ _d | | 640 | | nm | |
| | Reverse Voltage/Segment or DP ⁽⁴⁾ | V _R | 3.0 | 12 | | V | I _F = 100 μA |
| | Temperature Coefficient of V _F /Segment or DP | ΔV _F /°C | | -2 | | mV/°C | |
| | Thermal Resistance LED Junction-to-Pin | Rθ _{J,PIN} | | 320 | | °C/W/Seg | |

AlGaAs Red

| Device Series | Parameter | Symbol | Min. | Typ. | Max. | Units | Test Conditions |
|--------------------|--|-----------------------------|------|------|------|----------|-------------------------|
| HDSP-F15X/ G15X | Luminous Intensity/Segment ^(1,2,5) (Digit Average) | I_V | 7.5 | 15.0 | | mcd | $I_F = 20 \text{ mA}$ |
| | Forward Voltage/Segment or DP | V_F | | 1.8 | 2.2 | V | $I_F = 20 \text{ mA}$ |
| | Peak Wavelength | λ_{PEAK} | | 645 | | nm | |
| | Dominant Wavelength ⁽³⁾ | λ_d | | 637 | | nm | |
| | Reverse Voltage/Segment or DP ⁽⁴⁾ | V_R | 3.0 | 15 | | V | $I_R = 100 \mu\text{A}$ |
| | Temperature Coefficient of V_F /Segment or DP | $\Delta V_F/^\circ\text{C}$ | | -2 | | mV/°C | |
| | Thermal Resistance LED Junction-to-Pin | $R\theta_{J-PIN}$ | | 320 | | °C/W/Seg | |

High Efficiency Red

| Device Series | Parameter | Symbol | Min. | Typ. | Max. | Units | Test Conditions |
|--------------------|--|-----------------------------|------|------|------|----------------|-------------------------|
| HDSP-F20X/ G20X | Luminous Intensity/Segment ^(1,2) (Digit Average) | I_V | 420 | 1200 | | μcd | $I_F = 5 \text{ mA}$ |
| | Forward Voltage/Segment or DP | V_F | | 2.0 | 2.5 | V | $I_F = 20 \text{ mA}$ |
| | Peak Wavelength | λ_{PEAK} | | 635 | | nm | |
| | Dominant Wavelength ⁽³⁾ | λ_d | | 626 | | nm | |
| | Reverse Voltage/Segment or DP ⁽⁴⁾ | V_R | 3.0 | 30 | | V | $I_R = 100 \mu\text{A}$ |
| | Temperature Coefficient of V_F /Segment or DP | $\Delta V_F/^\circ\text{C}$ | | -2 | | mV/°C | |
| | Thermal Resistance LED Junction-to-Pin | $R\theta_{J-PIN}$ | | 320 | | °C/W/Seg | |

Orange

| Device Series | Parameter | Symbol | Min. | Typ. | Max. | Units | Test Conditions |
|----------------|--|-------------------------------|------|------|------|------------------------|-------------------------|
| HDSP-F40X/G40X | Luminous Intensity/Segment ^(1,2) (Digit Average) | I_V | 420 | 1200 | | μcd | $I_F = 5 \text{ mA}$ |
| | Forward Voltage/Segment or DP | V_F | | 2.0 | 2.5 | V | $I_F = 20 \text{ mA}$ |
| | Peak Wavelength | λ_{PEAK} | | 600 | | nm | |
| | Dominant Wavelength ⁽³⁾ | λ_d | | 603 | | nm | |
| | Reverse Voltage/Segment or DP ⁽⁴⁾ | V_R | 3.0 | 30 | | V | $I_R = 100 \mu\text{A}$ |
| | Temperature Coefficient of V_F /Segment or DP | $\Delta V_F / ^\circ\text{C}$ | | -2 | | mV/ $^\circ\text{C}$ | |
| | Thermal Resistance LED Junction-to-Pin | $R\theta_{\text{J,PIN}}$ | | 320 | | $^\circ\text{C/W/Seg}$ | |

SEVEN SEGMENT NUMBER DISPLAYS

Yellow

| Device Series | Parameter | Symbol | Min. | Typ. | Max. | Units | Test Conditions |
|----------------|--|-------------------------------|-------|------|-------|------------------------|-------------------------|
| HDSP-F30X/G30X | Luminous Intensity/Segment ^(1,2) (Digit Average) | I_V | 290 | 800 | | μcd | $I_F = 5 \text{ mA}$ |
| | Forward Voltage/Segment or DP | V_F | | 2.2 | 2.5 | V | $I_F = 20 \text{ mA}$ |
| | Peak Wavelength | λ_{PEAK} | | 583 | | nm | |
| | Dominant Wavelength ^(3,6) | λ_d | 581.5 | 586 | 592.5 | nm | |
| | Reverse Voltage/Segment or DP ⁽⁴⁾ | V_R | 3.0 | 40 | | V | $I_R = 100 \mu\text{A}$ |
| | Temperature Coefficient of V_F /Segment or DP | $\Delta V_F / ^\circ\text{C}$ | | -2 | | mV/ $^\circ\text{C}$ | |
| | Thermal Resistance LED Junction-to-Pin | $R\theta_{\text{J,PIN}}$ | | 320 | | $^\circ\text{C/W/Seg}$ | |

High Performance Green

| Device Series | Parameter | Symbol | Min. | Typ. | Max. | Units | Test Conditions |
|----------------|--|-------------------------------|------|------|------|------------------------|-------------------------|
| HDSP-F50X/G50X | Luminous Intensity/Segment ^(1,2) (Digit Average) | I_V | 1030 | 3500 | | μcd | $I_P = 10 \text{ mA}$ |
| | Forward Voltage/Segment or DP | V_F | | 2.1 | 2.5 | V | $I_P = 10 \text{ mA}$ |
| | Peak Wavelength | λ_{PEAK} | | 566 | | nm | |
| | Dominant Wavelength ^(3,6) | λ_d | | 571 | 577 | nm | |
| | Reverse Voltage/Segment or DP ⁽⁴⁾ | V_R | 3.0 | 50 | | V | $I_R = 100 \mu\text{A}$ |
| | Temperature Coefficient of V_F /Segment or DP | $\Delta V_F / ^\circ\text{C}$ | | -2 | | mV/ $^\circ\text{C}$ | |
| | Thermal Resistance LED Junction-to-Pin | $R\theta_{\text{J-PIN}}$ | | 320 | | $^\circ\text{C/W/Seg}$ | |

Notes:

1. Case temperature of device immediately prior to the intensity measurement is 25°C.
2. The digits are categorized for luminous intensity. The intensity category is designated by a letter on the side of the package.
3. The dominant wavelength, λ_d , is derived from the CIE chromaticity diagram and is that single wavelength which defines the color of the device.
4. Typical specification for reference only. Do not exceed absolute maximum ratings.
5. For low current operation, the AlGaAs HDSP-F10X, G10X series displays are recommended. They are tested at 1 mA dc/segment and are pin for pin compatible with the HDSP-F15X/G15X series.
6. The Yellow (HDSP-F30X/G30X) series and Green (HDSP-F50X/G50X) series displays are categorized for dominant wavelength. The category is designated by a number adjacent to the luminous intensity category letter.

RED, AlGaAs Red

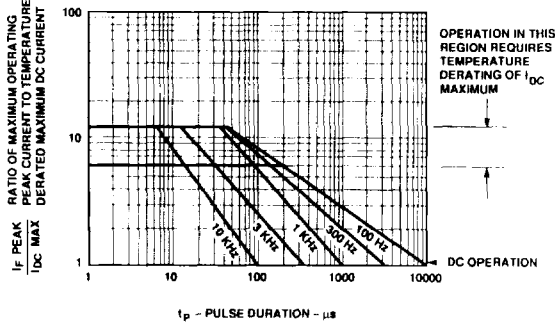

Figure 1. Maximum Tolerable Peak Current vs. Pulse Duration - Red.

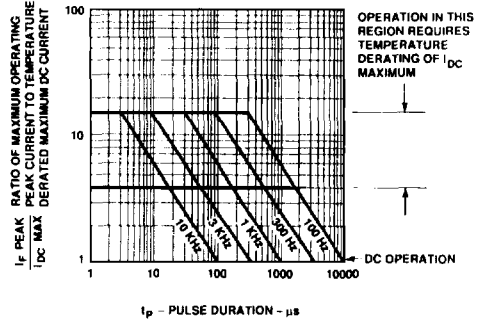

Figure 2. Maximum Tolerable Peak Current vs. Pulse Duration - AlGaAs Red.

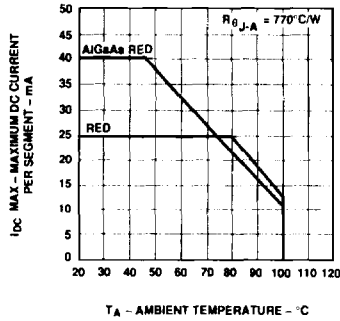

Figure 3. Maximum Allowable DC Current vs. Ambient Temperature.

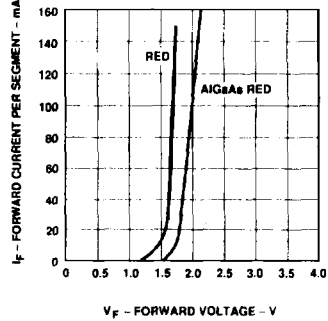

Figure 4. Forward Current vs. Forward Voltage.

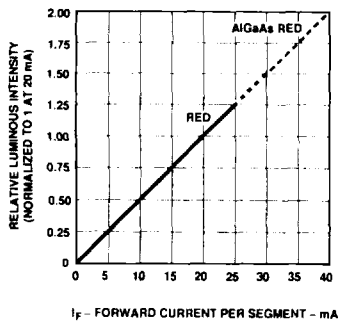

Figure 5. Relative Luminous Intensity vs. DC Forward Current.

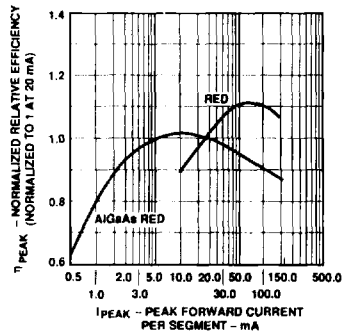

Figure 6. Relative Efficiency (Luminous Intensity per Unit Current) vs. Peak Current.

SEVEN SEGMENT NUMERIC DISPLAYS

HER, Orange, Yellow, Green

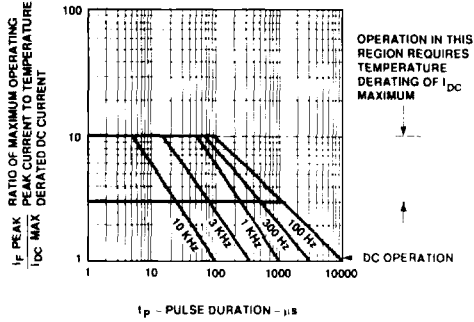

Figure 7. Maximum Tolerable Peak Current vs. Pulse Duration - HER, Orange.

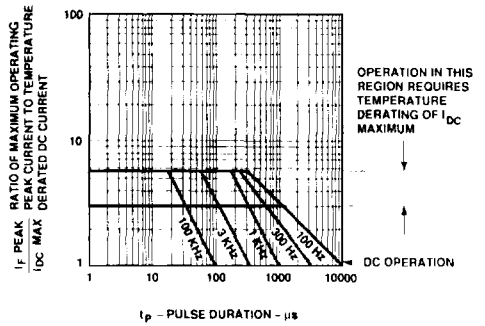

Figure 8. Maximum Tolerable Peak Current vs. Pulse Duration - Yellow.

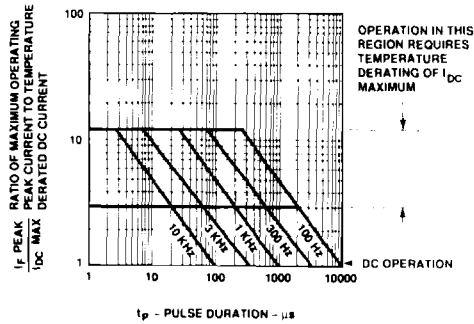

Figure 9. Maximum Tolerable Peak Current vs. Pulse Duration - Green.

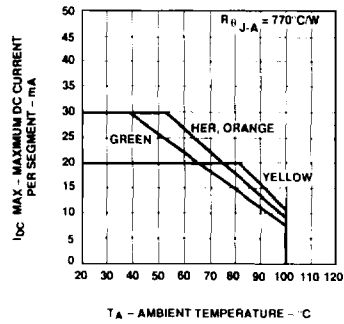

Figure 10. Maximum Allowable DC Current vs. Ambient Temperature.

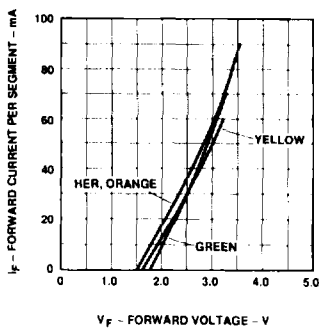

Figure 11. Forward Current vs. Forward Voltage Characteristics.

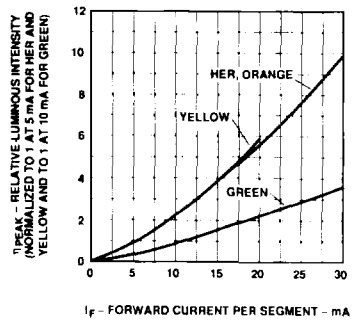

Figure 12. Relative Luminous Intensity vs. DC Forward Current.

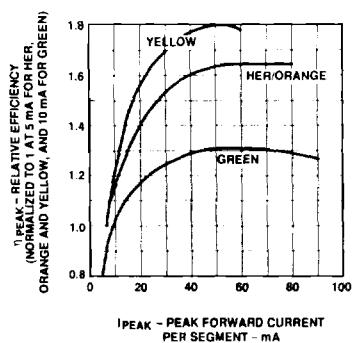

Figure 13. Relative Efficiency (Luminous Intensity per Unit Current) vs. Peak Current.

Contrast Enhancement

For information on contrast enhancement please see Application Note 1015.

Soldering/Cleaning

Cleaning agents from the ketone family (acetone, methyl ethyl ketone, etc.) and from the chlorinated hydrocarbon family (methylene chloride, trichloroethylene, carbon tetrachloride, etc.) are not recommended for cleaning LED parts. All of these various solvents attack or dissolve the encapsulating epoxies used to form the package of plastic LED parts.

For information on soldering LEDs please refer to Application Note 1027.