

Thermopile Infrared Detectors

Dual Channel Thermopile TPS 2534

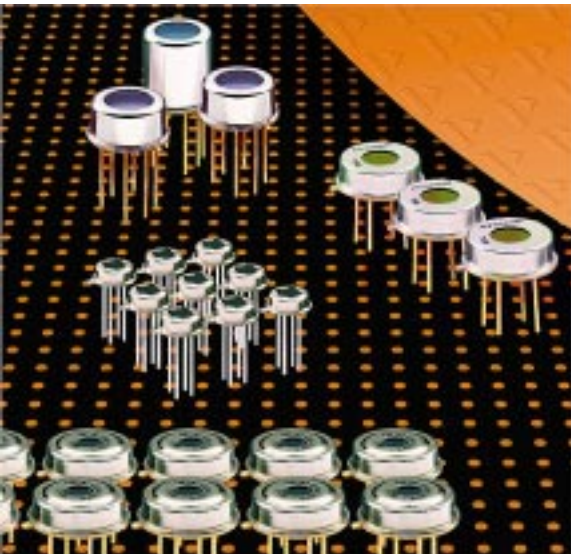

Two thermopiles with individual infrared filters

Thermistor temperature reference included

Applications: infrared absorption (NDIR) gas sensing with reference channel

The dual thermopile sensor **TPS 2534** employs two single thermopile chips mounted in a TO 5-type housing with a 30 kΩ thermistor as temperature reference. The cap has two windows of size 2.3 x 2.6 mm² each which can be equipped with different infrared bandpass filters. The sensor is perfectly suited to gas detection by IR absorption.

For further information please refer to the TPS 2534 product note.

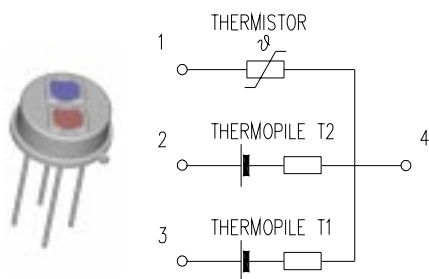

Parameters	TPS 2534		
	typical	units	condition
Sensitive area	2x 1.2 x 1.2	mm ²	absorbing area
Window size	2.3 x 2.6	mm ²	each channel
DC sensitivity	42	V/W	500K BB w/o filter
Resistance	30	kΩ	
Noise	30	nV/√Hz	r.m.s. 300K
NEP	10.7	nW/√Hz	500K BB w/o filter
D*	2.3 x 10 ⁸	cm√Hz/W	500K BB w/o filter
TC of sensitivity	-0.01	%/K	
TC of resistance	0.02	%/K	
Time constant	35	ms	
Operating temperature	-40	100	°C non permanent
Storage temperature	-40	100	°C non permanent
Thermistor resistance	30	kΩ	25°C
beta	3964	K	25°C/100°C
Field of view	2x 90	°	at 50% points

Right for modification reserved / WS / 21.5.2001

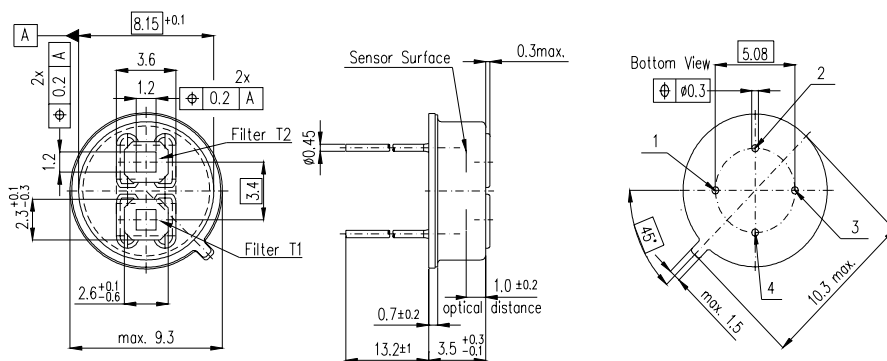
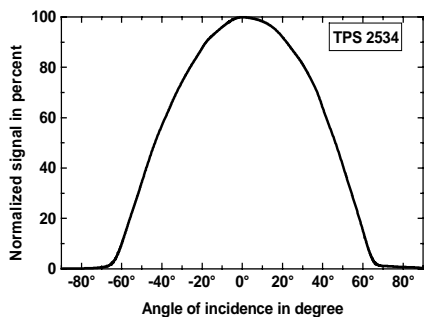
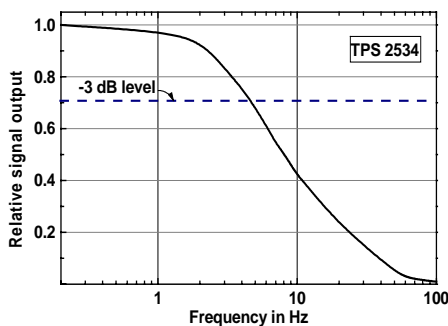

Dimensions in mm

Europe:
PerkinElmer Optoelectronics GmbH
 Wenzel Jaksch Str 31
 Wiesbaden / Germany
 Phone +49(0)611 492 0
 Fax +49(0)611 492 170

USA:
PerkinElmer Optoelectronics
 2175 Mission College Blvd
 Santa Clara, CA 95054
 Phone +408 565 0830
 Fax +408 565 0703

Asia:
PerkinElmer Optoelectronics
 47, Ayer Rajah Crescent #06-12
 Singapore 139947
 Phone +65 775 2022
 Fax +65 775 1008

