

VEP Series



GREEN XP POWER

- Efficiency Efficiency Level V (24 W Level IV)
- CEC2008 & EISA 2007 Compliant
- IT & Medical Approvals
- Interchangeable Input Connectors
- Output Voltages from 5 V to 24 V Available
- Class II Construction
- Low Cost

Specification

Input

Input Voltage	<ul style="list-style-type: none"> • 8 & 15W: 80-264 VAC • 24 W: 80-264 VAC, derate output power 25% <90 VAC • 36 W: 90-264 VAC
Input Frequency	<ul style="list-style-type: none"> • 47-63 Hz
Input Current	<ul style="list-style-type: none"> • 8 W: 0.3 A max at 90 VAC • 15 W: 0.5 A max at 90 VAC • 24 W: 0.6 A max at 90 VAC • 36 W: 0.9 A max at 90 VAC
Inrush Current	<ul style="list-style-type: none"> • 70 A max at 230 VAC, cold start at 25 °C
Power Factor	<ul style="list-style-type: none"> • EN61000-3-2, class A
No Load Input Power	<ul style="list-style-type: none"> • <0.3 W

Output

Output Voltage	<ul style="list-style-type: none"> • See tables
Initial Set Accuracy	<ul style="list-style-type: none"> • $\pm 5\%$ at 50% load
Minimum Load	<ul style="list-style-type: none"> • No minimum load required
Start Up Delay	<ul style="list-style-type: none"> • 2 s typical
Start Up Rise Time	<ul style="list-style-type: none"> • 8 & 15 W: 100 ms typical, • 24 & 36 W: 50 ms typical
Hold Up Time	<ul style="list-style-type: none"> • 5 ms typical at full load and 115 VAC
Line Regulation	<ul style="list-style-type: none"> • $\pm 0.5\%$ max
Load Regulation	<ul style="list-style-type: none"> • $\pm 5\%$ max
Transient Response	<ul style="list-style-type: none"> • 4% max. deviation, recovery to <1% within 500 μs for a 50% step load change at 0.2 A/μs
Ripple & Noise	<ul style="list-style-type: none"> • See tables
Overvoltage Protection	<ul style="list-style-type: none"> • See tables
Overload Protection	<ul style="list-style-type: none"> • 120-280%
Short Circuit Protection	<ul style="list-style-type: none"> • Trip and restart (hiccup mode)
Temperature Coefficient	<ul style="list-style-type: none"> • 0.2 %/°C

General

Efficiency	<ul style="list-style-type: none"> • See tables
Energy Efficiency	<ul style="list-style-type: none"> • Level V • Level IV (24 W versions)
Isolation	<ul style="list-style-type: none"> • 8 - 24 W: 4000 VAC Input to Output, • 36 W: 3000 VAC Input to Output
Switching Frequency	<ul style="list-style-type: none"> • 8 & 15 W: 132 kHz typical, • 24 & 36 W: 65 kHz typical
MTBF	<ul style="list-style-type: none"> • 8 - 24 W: 250 kHrs, 36 W: 200 kHrs to MIL-HDBK-217F at 25°C, GB

Environmental

Operating Temperature	<ul style="list-style-type: none"> • 0 °C to +40 °C
Cooling	<ul style="list-style-type: none"> • Natural convection
Operating Humidity	<ul style="list-style-type: none"> • 5-95% RH, non-condensing
Storage Temperature	<ul style="list-style-type: none"> • -20 °C to +60 °C
Shock	<ul style="list-style-type: none"> • Able to survive 1 m drop onto concrete on each of 6 axes
Vibration	<ul style="list-style-type: none"> • 10-300 Hz, 1 g 15 mins/sweep. 30 mins for each of 3 axes

EMC & Safety

Emissions	<ul style="list-style-type: none"> • EN55022, class B conducted & radiated
Harmonic Currents	<ul style="list-style-type: none"> • EN61000-3-2, class A
Voltage Flicker	<ul style="list-style-type: none"> • EN61000-3-3
ESD Immunity	<ul style="list-style-type: none"> • EN61000-4-2, ± 4 kV contact, ± 8 kV air, Perf Criteria A
Radiated Immunity	<ul style="list-style-type: none"> • EN61000-4-3, 3 V/m, Perf Criteria A
EFT/Burst	<ul style="list-style-type: none"> • EN61000-4-4, level 2, Perf Criteria A
Surge	<ul style="list-style-type: none"> • EN61000-4-5, installation class 3, Perf Criteria A
Conducted Immunity	<ul style="list-style-type: none"> • EN61000-4-6, 3 V, Perf Criteria A
Magnetic Field	<ul style="list-style-type: none"> • EN61000-4-8, 1 A/m, Perf Criteria A
Dips & Interruptions	<ul style="list-style-type: none"> • EN61000-4-11, 30% 10 ms, 60% 100 ms, 100% 5000 ms, Perf Criteria A, B, B
Safety Approvals	<ul style="list-style-type: none"> • 8 & 15 W: EN60950-1, cUL60950-1, IEC60950-1, EN60601-1, cUL60601-1, IEC60601-1; • 24 W: EN60950-1, cCSAus60950-1, IEC60950-1, CSA60950-01-03, cCSAus60601-1, UL60601-1, IEC60601-1, CSA C22.2 No601.1, • 36 W: IEC60950-1, EN60950-1, UL60950-1

Models and Ratings

Output Power	Output Voltage ⁽²⁾	Output Current	Ripple & Noise ⁽¹⁾	Oversvoltage Trip ⁽⁵⁾	Efficiency ⁽⁴⁾	Model Number ⁽³⁾
8.0 W	5.0 V	1.60 A	150 mV	10.0 V	74%	VEP08US05†^
8.0 W	9.0 V	0.88 A	200 mV	18.0 V	77%	VEP08US09†^
8.0 W	12.0 V	0.66 A	200 mV	20.0 V	77%	VEP08US12†^
8.0 W	15.0 V	0.53 A	200 mV	25.0 V	78%	VEP08US15
10.0 W	5.0 V	2.00 A	50 mV	9.0 V	75%	VEP15US05†^
12.6 W	9.0 V	1.40 A	100 mV	15.0 V	80%	VEP15US09†^
15.0 W	12.0 V	1.25 A	100 mV	20.0 V	82%	VEP15US12†^
15.0 W	15.0 V	0.90 A	150 mV	25.0 V	84%	VEP15US15
15.0 W	24.0 V	0.63 A	200 mV	35.0 V	83%	VEP15US24†^

Notes

1. Measured at end of DC output lead using 20 MHz bandwidth and 0.1 μF ceramic capacitor in parallel with 10 μF electrolytic capacitor placed at connector terminals.
2. VEP08 models: Other voltages between 3.0 V and 18.0 V are available on request, consult sales for details.
VEP15 models: Other voltages between 3.0 V and 24.0 V are available on request, consult sales for details.
3. A suffix denoting the type of mains plug required must be added to the part number. See below.
4. Efficiency given is the average of efficiencies measured with output loads of 25%, 50%, 75% and 100%.
5. VEP08 models: Typical trip point, VEP15 models: Maximum trip point.

† Available from Farnell & element14. See pages 284-290.

^ Available from Newark. See pages 291-296

Mechanical Details

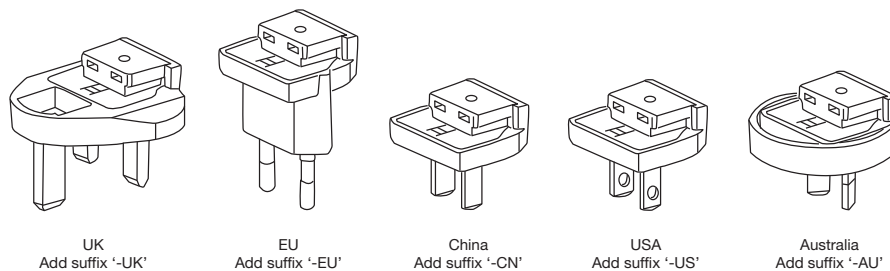
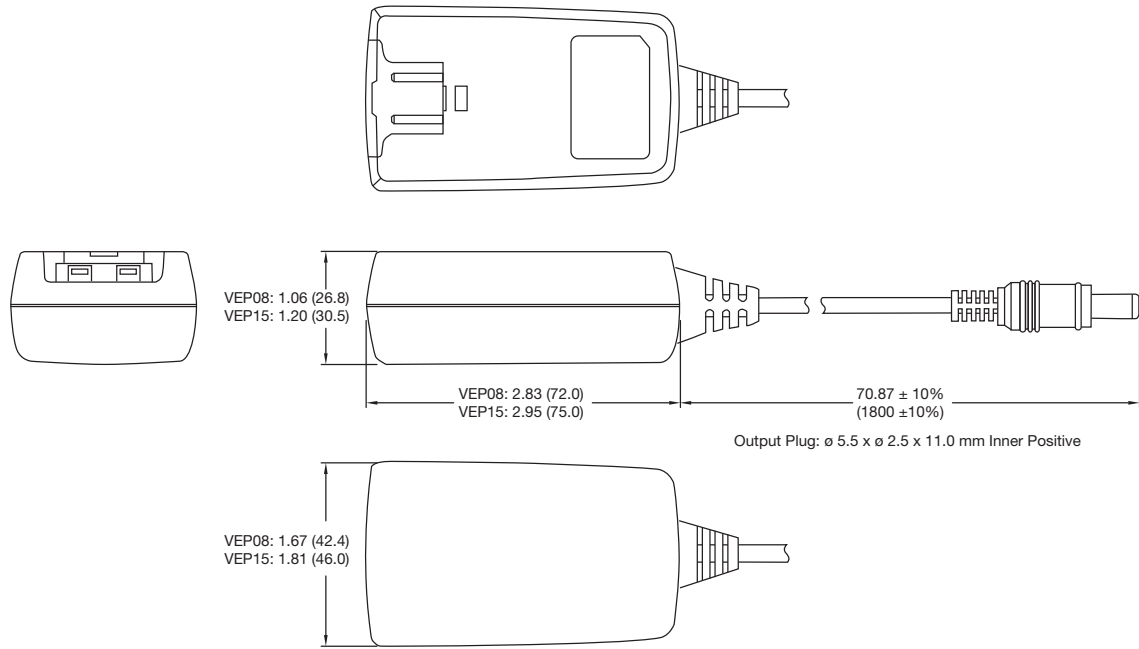

Notes

1. All dimensions in inches (mm). Tolerance is ±0.04 (±1) maximum, except output cable length.
2. Weight: VEP08 - 0.18 lbs (80 g) approx., VEP15 - 0.26 lbs (120 g) approx.
3. Case material is PC Class 94 V-0
4. Output Lead: UL2468 18-24 AWG
5. Mains plugs can be ordered separately. Part numbers are: VEP PLUG UK†^, VEP PLUG EU†^, VEP PLUG CN^, VEP PLUG US†^ or VEP PLUG AU^

Models and Ratings

Output Power	Output Voltage ⁽³⁾	Output Current	Ripple & Noise ⁽¹⁾	Oversvoltage Trip ⁽⁵⁾	Efficiency ⁽⁴⁾	Model Number ⁽²⁾
12.5 W	5.0 V	2.5 A	100 mV	10.0 V	73%	VEP24US05†^
19.8 W	9.0 V	2.2 A	100 mV	18.0 V	77%	VEP24US09†^
24.0 W	12.0 V	2.0 A	100 mV	20.0 V	78%	VEP24US12†^
24.0 W	15.0 V	1.6 A	100 mV	25.0 V	78%	VEP24US15
24.0 W	24.0 V	1.0 A	100 mV	35.0 V	78%	VEP24US24†^

Notes

1. Measured at end of DC output lead using 20 MHz bandwidth and 0.1 μF ceramic capacitor in parallel with 10 μF electrolytic capacitor placed at connector terminals.
2. A suffix denoting the type of mains plug required must be added to the part number. See below.
3. Other voltages between 3.0 V and 24.0 V are available on request, consult sales for details.
4. Efficiency given is the average of efficiencies measured with output loads of 25%, 50%, 75% and 100%.
5. Typical trip point.

† Available from Farnell & element14. See pages 284-290.

^ Available from Newark. See pages 291-296

Mechanical Details

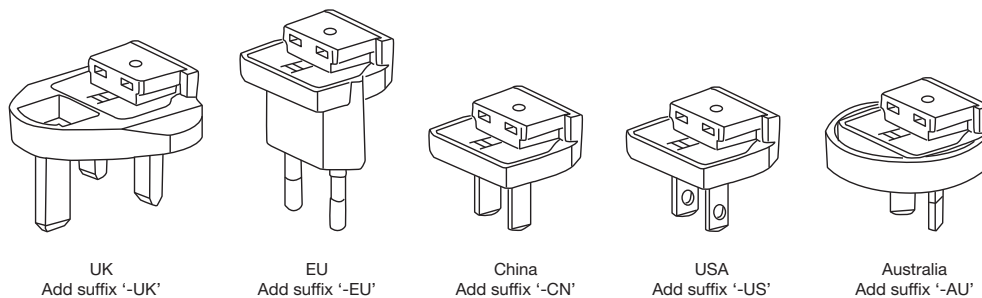
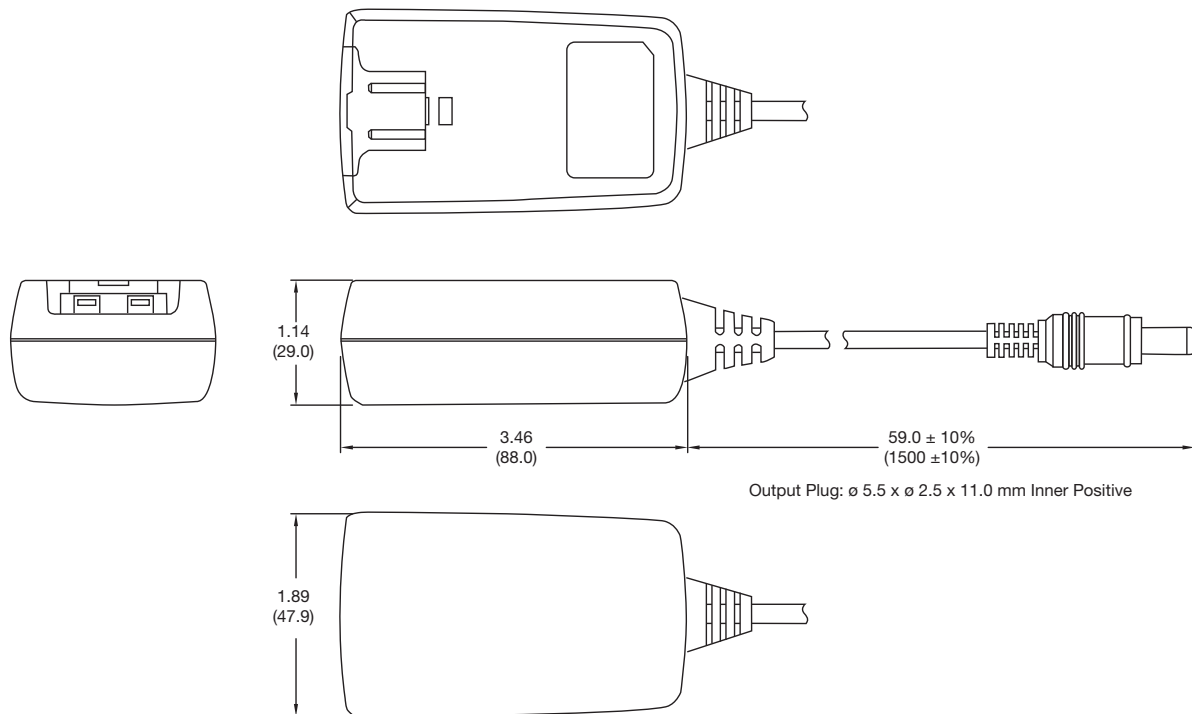

Notes

1. All dimensions in inches (mm). Tolerance is ±0.04 (±1) maximum, except output cable length
2. Weight: 0.35 lbs (160 g) Approx
3. Case material is PC Class 94 V-0
4. Output Lead: UL2468 18-24 AWG
5. Mains plugs can be ordered separately. Part numbers are: VEP PLUG UK†^, VEP PLUG EU†^, VEP PLUG CN^, VEP PLUG US†^ or VEP PLUG AU^

Models and Ratings

Output Power	Output Voltage ⁽³⁾	Output Current	Ripple & Noise ⁽¹⁾	Oversoltage Trip ⁽⁴⁾	Efficiency ⁽³⁾	Model Number ⁽²⁾
27 W	9.0 V	3.0 A	200 mV	25.0 V	82%	VEP36US09†^
36 W	12.0 V	3.0 A	200 mV	28.0 V	84%	VEP36US12†^
36 W	15.0 V	2.4 A	200 mV	28.0 V	84%	VEP36US15†^
36 W	24.0 V	1.5 A	200 mV	42.0 V	84%	VEP36US24†^

Notes

1. Measured at end of DC output lead using 20 MHz bandwidth and 0.1 μF ceramic capacitor in parallel with 10 μF electrolytic capacitor placed at connector terminals.
2. A suffix denoting the type of mains plug required must be added to the part number. See below.
3. Efficiency given is the average of efficiencies measured with output loads of 25%, 50%, 75% and 100%.
4. Typical trip point.

† Available from Farnell & element14. See pages 284-290.

^ Available from Newark. See pages 291-296

Mechanical Details

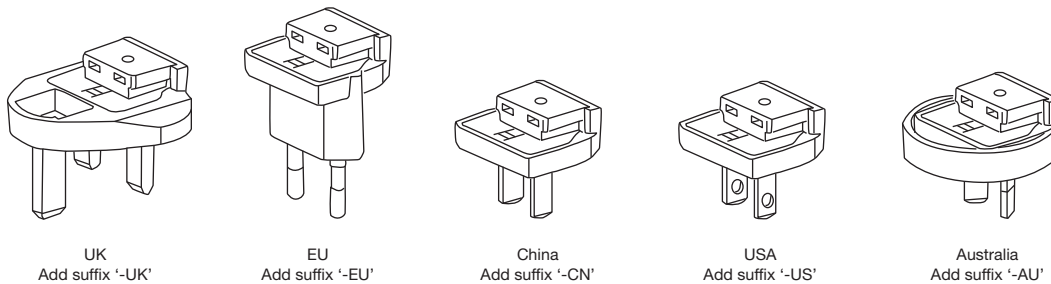
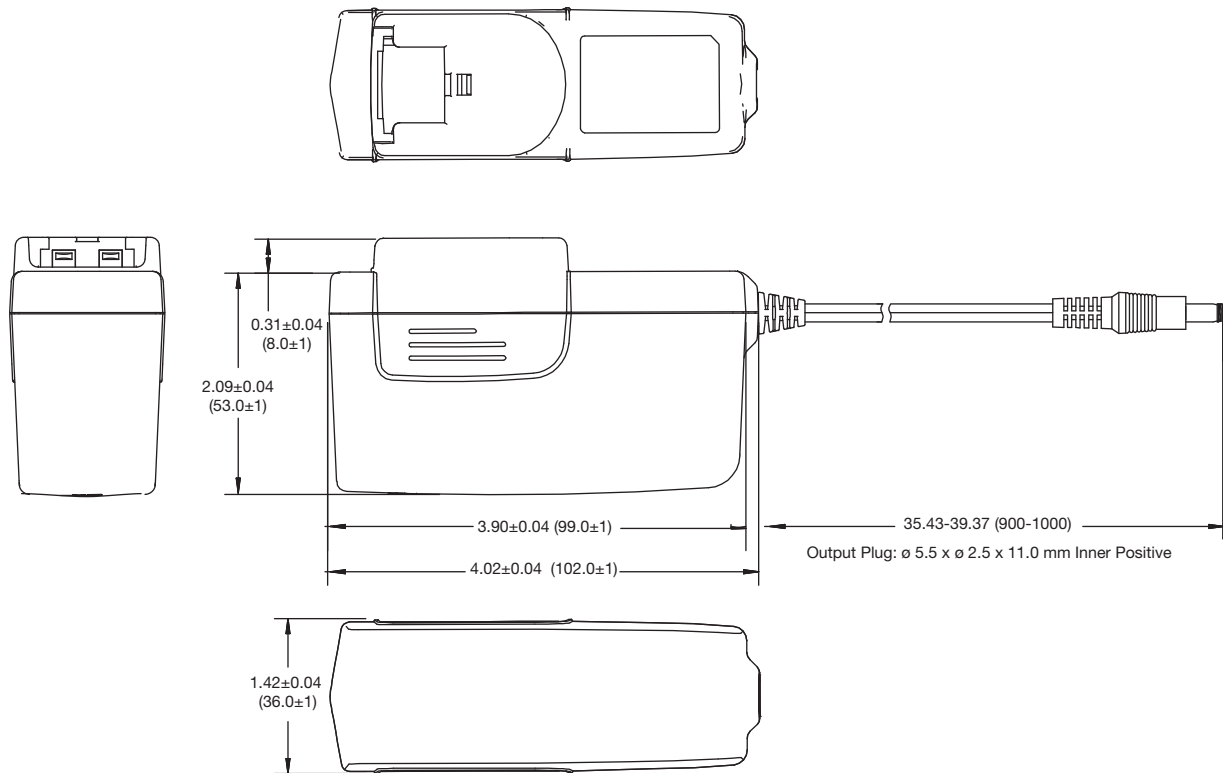

Notes

1. All dimensions in inches (mm). Tolerance is ±0.04 (±1) maximum, except output cable length
2. Weight: 0.57 lbs (260 g) Approx
3. Case material is PC Class 94 V-0
4. Output Lead: UL2468 18-24 AWG
5. Mains plugs can be ordered separately. Part numbers are: VEP PLUG UK†^, VEP PLUG EU†^, VEP PLUG CN^, VEP PLUG US†^ or VEP PLUG AU^