



# GBPC 40, 50 SERIES

High Current 40, 50 AMPS. Single Phase  
Glass Passivated Bridge Rectifiers

## Features

- ✧ UL Recognized File # E-326243
- ✧ Glass passivated junction
- ✧ The plastic material used carries Underwriters Laboratory Flammability Recognition 94V-0
- ✧ Integrally molded heatsink provide very low thermal resistance for maximum heat dissipation
- ✧ Universal 4-way terminals; snap-on, wrap-around, solder or P.C. board mounting
- ✧ Surge overload ratings 400 amperes
- ✧ Typical  $I_R$  less than 0.2 uA
- ✧ High temperature soldering guaranteed: 260 °C / 10 seconds / .375", (9.5mm) lead lengths
- ✧ Isolated voltage from case to lead over 2500 volts

## GBPC40

## GBPC40 -M

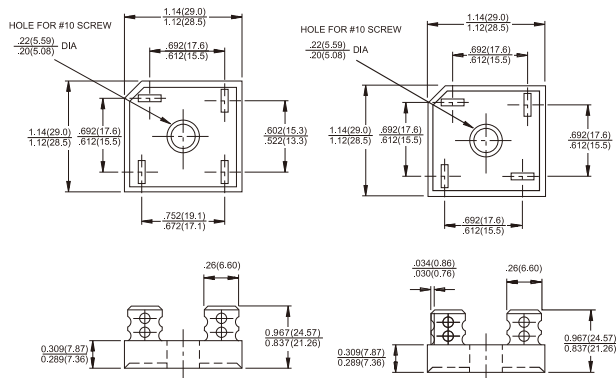

Dimensions in inches and (millimeters)

## Mechanical Data

- ✧ Case: Molded plastic body.
- ✧ Terminals: Pure tin plated, Lead free. leads solderable per MIL-STD-202, Method 208 .
- ✧ Weight: 17.37 grams
- ✧ Mounting position: Any
- ✧ Mounting Torque: 20 inches-lbs. max.

## Maximum Ratings and Electrical Characteristics

Rating at 25 °C ambient temperature unless otherwise specified.

Single phase, half wave, 60 Hz, resistive or inductive load.

For capacitive load, derate current by 20%

Type Number	Symbol	-005	-01	-02	-04	-06	-08	-10	Units
Maximum Recurrent Peak Reverse Voltage	VRRM	50	100	200	400	600	800	1000	V
Maximum RMS Voltage	VRMS	35	70	140	280	420	560	700	V
Maximum DC Blocking Voltage	VDC	50	100	200	400	600	800	1000	V
Maximum Average Forward Rectified Current @T <sub>c</sub> = 55 °C GBPC40 GBPC50	I <sub>F(AV)</sub>				40.0 50.0				A
Peak Forward Surge Current, Single Sine-wave Superimposed on Rated Load (JEDEC method ) GBPC40 GBPC50	I <sub>FSM</sub>				400 400				A
Maximum Instantaneous Forward Voltage Drop Per Element at Specified Current GBPC40 @20A GBPC50 @25A	V <sub>F</sub>				1.1				V
Maximum DC Reverse Current at Rated DC Blocking Voltage Per Element (Note 1)	I <sub>R</sub>				10				uA
Typical Thermal Resistance	R <sub>θJC</sub>				1.5				°C/W
Operating and Storage Temperature Range	T <sub>J</sub> , T <sub>STG</sub>				-50 to +150				°C

Notes: 1. Pulse Test with PW=300 usec, 1% Duty Cycle  
2. Suffix "M" - Terminal Location Face to Face.

**RATINGS AND CHARACTERISTIC CURVES ( GBPC40005 THRU GBPC4010  
GBPC50005 GBPC5010 )**

**FIG.1- MAXIMUM FORWARD CURRENT DERATING CURVE**

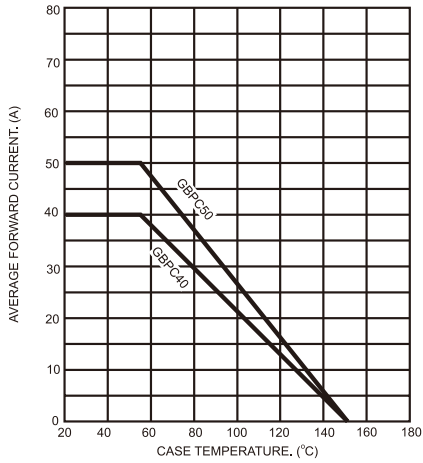

**FIG.2- TYPICAL REVERSE CHARACTERISTICS PER BRIDGE ELEMENT**

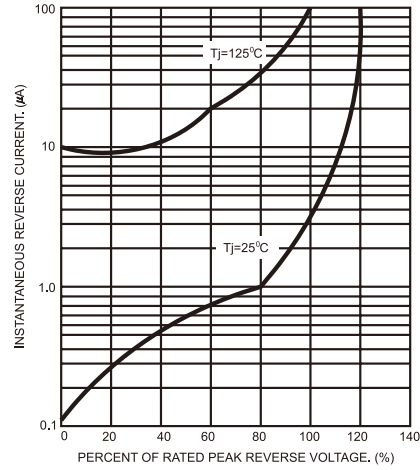

**FIG.3- MAXIMUM NON-REPETITIVE FORWARD SURGE CURRENT**

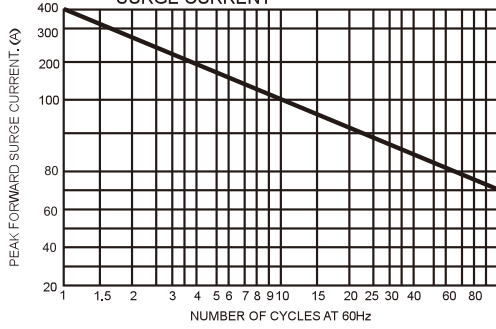

**FIG.4- TYPICAL FORWARD CHARACTERISTICS PER BRIDGE ELEMENT**

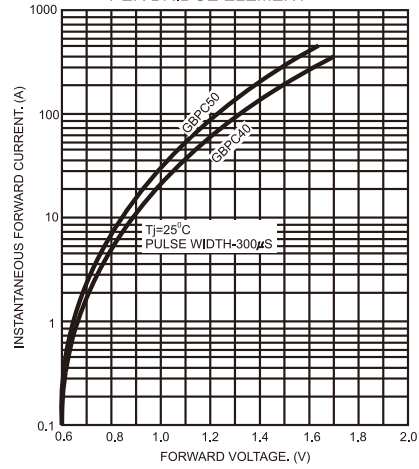

**FIG.5- TYPICAL JUNCTION CAPACITANCE**

