

# PRELIMINARY

APT10050FN 1000V 22.5A 0.50 Ω

## POWER MOS IV™

### N - CHANNEL ENHANCEMENT MODE HIGH VOLTAGE POWER MOSFETS

#### MAXIMUM RATINGS

All Ratings:  $T_C = 25^\circ\text{C}$  unless otherwise specified.

Symbol	Parameter	APT10050FN	UNIT
$V_{DSS}$	Drain-Source Voltage	1000	Volts
$I_D$	Continuous Drain Current	22.5	Amps
$I_{DM}$	Pulsed Drain Current <sup>1</sup>	90	Amps
$V_{GS}$	Gate-Source Voltage	±30	Volts
$P_D$	Total Power Dissipation @ $T_C = 25^\circ\text{C}$ , Derate Above $25^\circ\text{C}$	595	Watts
$T_J, T_{STG}$	Operating and Storage Junction Temperature Range	-55 to 150	°C

#### STATIC ELECTRICAL CHARACTERISTICS

Symbol	Characteristic / Test Conditions	MIN	TYP	MAX	UNIT
$BV_{DSS}$	Drain-Source Breakdown Voltage ( $V_{GS} = 0V, I_D = 250\mu\text{A}$ )	APT10050FN	1000		Volts
					Volts
$I_{DSS}$	Zero Gate Voltage Drain Current ( $V_{DS} = V_{DSS}, V_{GS} = 0V$ )			250	$\mu\text{A}$
	( $V_{DS} = 0.8 V_{DSS}, V_{GS} = 0V, T_C = 125^\circ\text{C}$ )			1000	
$I_{GSS}$	Gate-Source Leakage Current ( $V_{GS} = \pm 30V, V_{DS} = 0V$ )			±100	nA
$I_D(ON)$	On State Drain Current <sup>2</sup> ( $V_{DS} > I_D(ON) \times R_{DS(ON)}$ Max, $V_{GS} = 10V$ )	22.5			Amps
$V_{GS(TH)}$	Gate Threshold Voltage ( $V_{DS} = V_{GS}, I_D = 1\text{mA}$ )	2		4	Volts
$R_{DS(ON)}$	Static Drain-Source On-State Resistance <sup>2</sup> ( $V_{GS} = 10V, I_D = 0.5 I_D(\text{Cont.})$ )			0.50	Ohms

#### THERMAL CHARACTERISTICS

Symbol	Characteristic	MIN	TYP	MAX	UNIT
$R_{\theta JC}$	Junction to Case			0.21	°C/W
$R_{\theta JA}$	Junction to Ambient			20	°C/W
$T_L$	Maximum Lead Temp. for Soldering Conditions: 0.063" from Case for 10 Sec.			300	°C

405 S.W. COLUMBIA STREET  
BEND, OREGON 97702  
U.S.A.

PHONE ... (503) 382-8028  
(800) 222-8APT  
FAX ..... (503) 388-0364

14

**DYNAMIC CHARACTERISTICS**

T-39-15

APT10050FN

Symbol	Characteristic	Test Conditions	MIN	TYP	MAX	UNIT
$C_{iss}$	Input Capacitance	$V_{GS} = 10V$ $V_{DS} = 25V$ $f = 1MHz$	4500		6300	pF
$C_{oss}$	Output Capacitance		960		1450	pF
$C_{rss}$	Reverse Transfer Capacitance		400		600	pF
$Q_g$	Total Gate Charge <sup>3</sup>	$V_{GS} = 10V, I_D = I_D(Cont.)$ $V_{DD} = 0.5 V_{DSS}$	160		260	nC
$Q_{gs}$	Gate-Source Charge		25		40	nC
$Q_{gd}$	Gate-Drain ("Miller") Charge		130		160	nC
$t_d(on)$	Turn-on Delay Time	$V_{DD} = 0.5 V_{DSS}$ $V_{GS} = 15V, I_D = I_D(Cont.)$ $R_G = 1.8\Omega$			30	nS
$t_r$	Rise Time				50	nS
$t_d(off)$	Turn-off Delay Time				130	nS
$t_f$	Fall Time				70	nS

**SOURCE-DRAIN DIODE RATINGS AND CHARACTERISTICS**

Symbol	Characteristic / Test Conditions	MIN	TYP	MAX	UNIT
$I_S$	Continuous Source Current (Body Diode)			22.5	Amps
$I_{SM}$	Pulsed Source Current <sup>1</sup> (Body Diode)			90	Amps
$V_{SD}$	Diode Forward Voltage <sup>2</sup> ( $V_{GS} = 0V, I_S = -I_D(Cont.)$ )			1.0	Volts
$t_{rr}$	Reverse Recovery Time ( $I_S = -I_D(Cont.)$ , $dI_S/dt = 100A/\mu s$ )			900	nS
$Q_{rr}$	Reverse Recovery Charge			14	$\mu C$

**SAFE OPERATING AREA CHARACTERISTICS**

Symbol	Characteristic	Test Conditions	MIN	TYP	MAX	UNIT
SOA1	Safe Operating Area	$V_{DS} = 0.4 V_{DSS}, I_{DS} = P_D / 0.4 V_{DSS}, t = 1 Sec.$	595			Watts
SOA2	Safe Operating Area	$V_{DS} = P_D / I_D(Cont.), I_{DS} = I_D(Cont.), t = 1 Sec.$	595			Watts
$I_{LM}$	Inductive Current Clamped		90			Amps

1.) Repetitive Rating: Pulse width limited by maximum junction temperature. See Transient Thermal Impedance Curve. (Fig.1)

2.) Pulse Test: Pulse Width < 380  $\mu s$   
Duty Cycle < 2%

3.) See JEDEC MIL-STD-750C Method 3471

PRELIMINARY

### APT PART NUMBERING SYSTEM - EXAMPLES

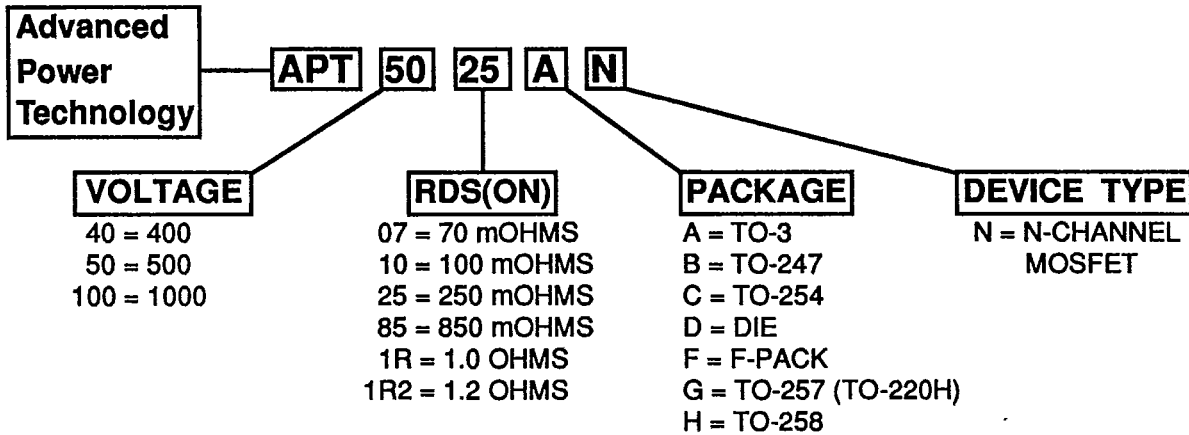

### PACKAGE OUTLINES

Package A TO-3 (TO-204AA)

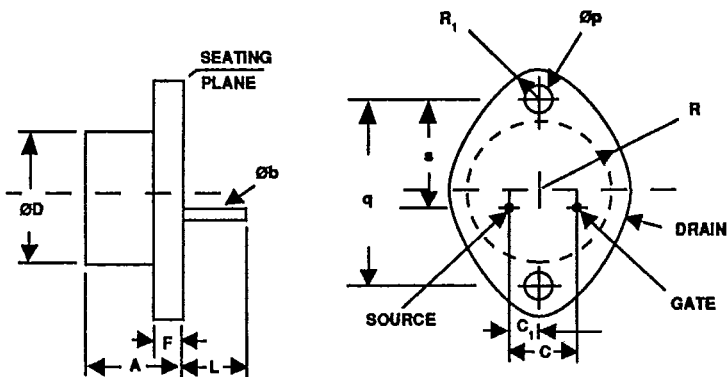

SYMBOL	INCHES		MILLIMETERS		NOTES
	MIN.	MAX.	MIN.	MAX.	
A	.250	.360	6.35	9.15	
Øb	.038	.043	.97	1.10	2
ØD		.875		22.23	
C	.420	.440	10.67	11.18	
C 1	.205	.225	5.21	5.72	
F	.060	.135	1.52	3.43	
L	.312	.500	7.92	12.70	2
Øp	.151	.161	3.84	4.09	
q	1.177	1.197	29.90	30.40	
R	.495	.525	12.57	13.34	
R 1	.131	.188	3.33	4.78	
s	.655	.675	16.64	17.15	1

**Notes:**

1. These dimensions should be measured at points .050" (1.27 mm) to .55" (1.40 mm) below seating plane. When gate is not used, measurement will be made at seating plane.
2. Two leads.

Package B TO-3P (TO-247 Type AD Proposed)

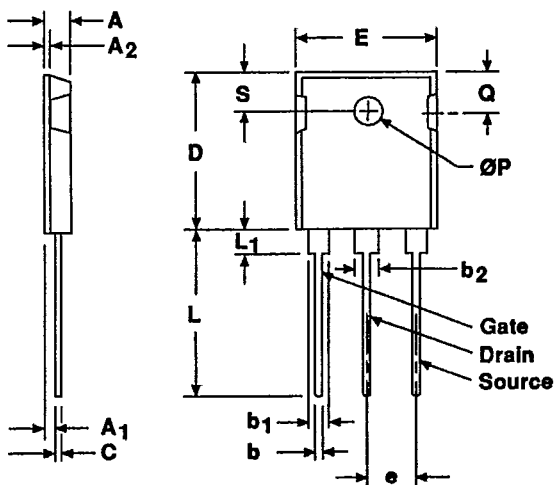

SYMBOL	INCHES		MILLIMETERS		NOTES
	MIN	MAX	MIN	MAX	
A	.185	.209	4.69	5.31	
A1	.087	.102	2.21	2.59	
A2	.059	.098	1.49	2.49	
b	.040	.055	1.01	1.40	4
b1	.065	.084	1.65	2.13	4
b2	.113	.123	2.87	3.12	
D	.016	.031	0.40	0.79	
E	.819	.845	20.80	21.46	
ØP	.610	.640	15.49	16.26	
e	.215 BSC		5.25 BSC		
L	.780	.800	19.81	20.32	
L1		.177		4.50	4
ØP	.140	.144	3.55	3.66	
Q	.212	.244	5.38	6.20	
S	.242 BSC		6.15 BSC		

**Notes:**

1. Refer to applicable symbol list.
2. Dimensions and tolerances per ANSI V14.5, 1982.
3. Maximum radius of .050 on all boot edges and corners.
4. Lead dimensions uncontrolled in L
5. Controlling dimension: Metric.

PACKAGE OUTLINES (Continued)

Package G TO-257AA (TO-220 Herm.)

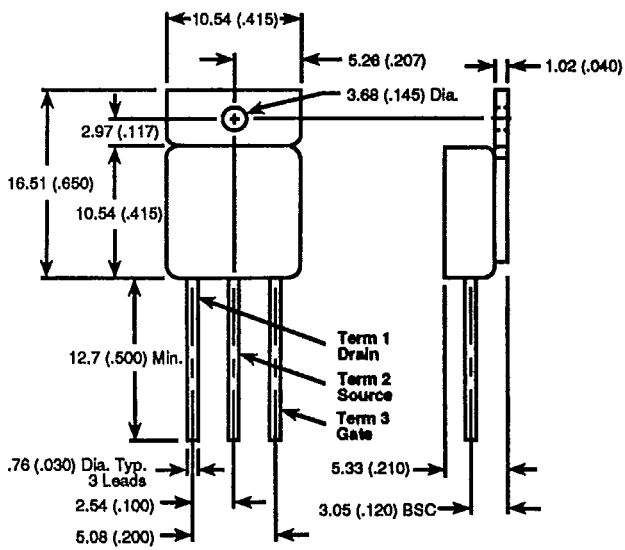

Package C TO-254AA

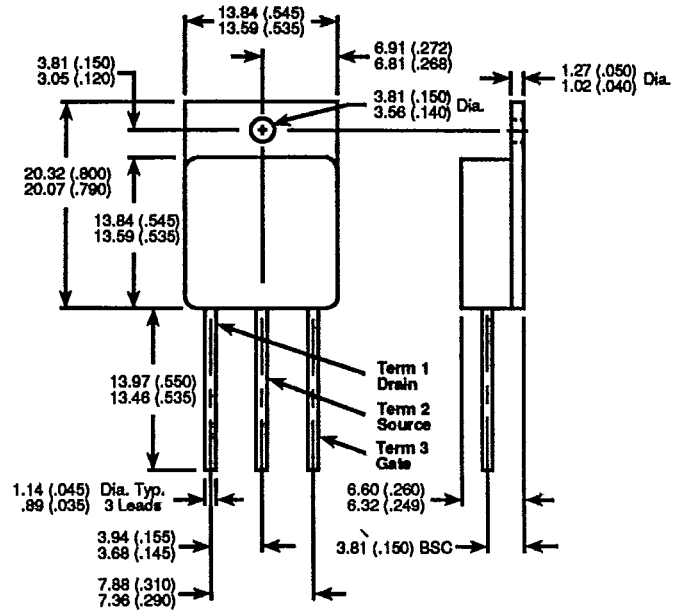

Package H TO-258AA (TO-247 Herm.)

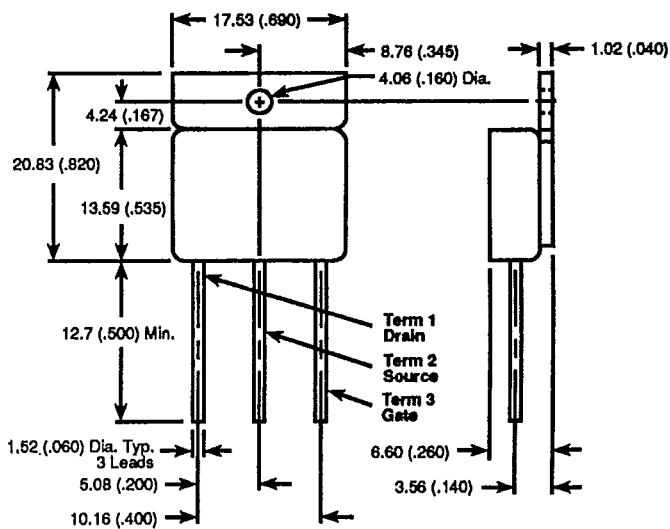

Package F (F-Pack)

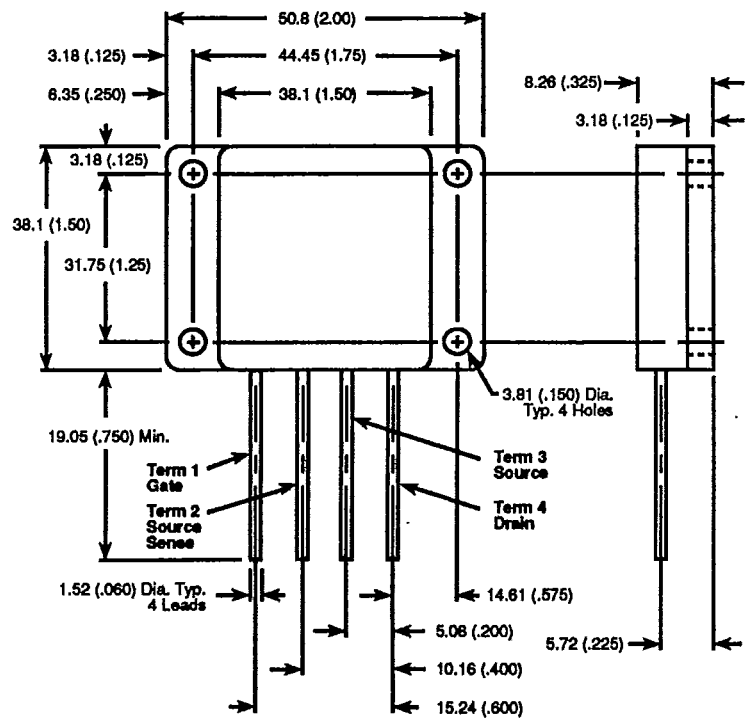

DIE TOPOGRAPHICAL LAYOUT DETAILS FOR APT POWER MOS IV™ DIE

**APT - 104** = .199 x .203 In.

● Source Pads = .036 In. diam  
 ■ Gate pads = .018 x .019 In.

Letters = Internal dimensions  
 A = .081 In. B = .039 In. C = .018 In.  
 D = .040 In. E = .082 In.

**APT - 105** = .290 x .250 In.

● Source Pads = .036 In. diam  
 ■ Gate pads = .018 x .019 In.

Letters = Internal dimensions  
 A = .055 In. B = .085 In. C = .105 In.  
 D = .042 In. E = .018 In.

**APT - 101** = .320 x .320 In.

▨ Source Pads = .037 x .024 In.  
 ▩ Source Pads = .030 x .024 In.  
 ■ Gate pads = .014 x .019 In.

Letters = Internal dimensions  
 A = .077 In. B = .062 In. C = .048 In.  
 D = .149 In. E = .018 In.

**APT - 102** = .414 x .254 In.

● Source Pads = .036 In. diam  
 ■ Gate pads = .012 x .019 In.

Letters = Internal dimensions  
 A = .117 In. B = .037 In. C = .097 In.  
 D = .031 In. E = .046 In.

**APT - 107** = .588 x .388 In.

● Source pads = .036  
 ■ Gate pads = .017 x .018

Letters = Internal dimensions  
 A = .057 In. B = .240 In. C = .151 In.  
 D = .045 In. E = .017 In. F = .091 In. G = .088 In.

A