

Rain sensors

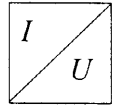

- Recognises rain on the windshield
- Differentiates between water drops, water splash, streaks, and dirt
- For integration in the windshield-wiper system
- Safety function in case of defects
- Improvement of passive safety in the vehicle

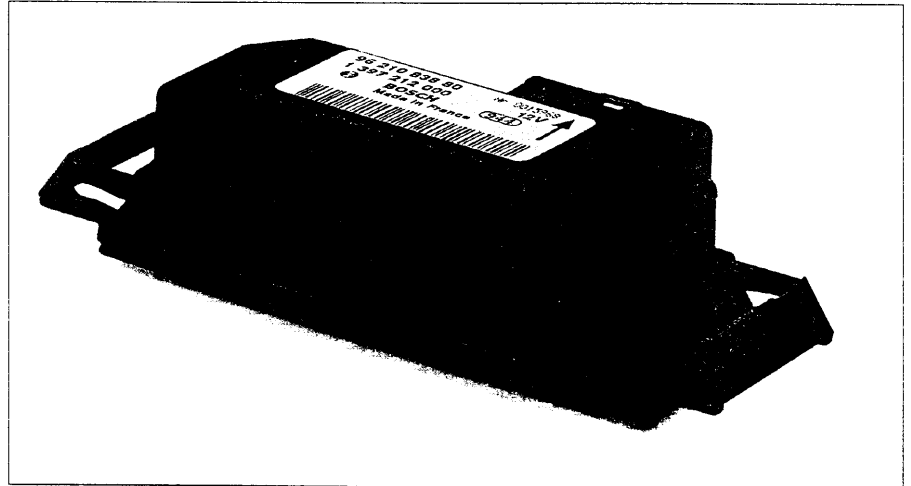

Application

For detecting a wet windshield (rain drops etc.) when the wiper system is in the automatic mode.

Design and function

The rain sensor is attached to the inside of the vehicle's windshield within the wiped area. If the windshield system is switched to automatic mode and drops of water fall on the windshield glass in the area covered by the sensor, this triggers a wiping cycle. The sensor's operation is based on an optical principle: A beam of light of known intensity is directed through a defined length of a sheet of glass by repeated total reflection within the glass. At a given point, optical decoupling is applied to deflect it out of the glass and into a measuring system where the residual light intensity is measured.

If there are water drops on the surface of the windshield, a portion of the light beam is not totally reflected, and emerges from the glass as a result. The resulting loss of light intensity is a measure of how much rain is falling on the windshield. The rain sensor and evaluation electronics are contained in a special housing which is clipped into clamps which are glued to the windshield.

A transmit diode and a receive diode, each together with two optical fibers and two silicone coupling pads (on the windshield side), form an optical measuring circuit. There is a heating area between the optical-fiber exit points so that the measurement cannot be falsified by misting-up of the inside of the windshield. The optical fibers are made of plastic which is resistant to both temperature and ageing.

The light leaving the transmit diode is focussed at the input lens of the first light guide and diverted at totally reflective surfaces so that at its point of exit it can enter the windshield at a defined angle, and in the form of a practically parallel light beam, through one of the snugly positioned silicon pads. Theoretically, following its re-entry

Technical data / Range

Part number	1 397 212 000
Glass thickness, permissible	5 mm ± 1 mm
Windshield curvature radius, permissible	2 m ... 6 m
Measuring surface, approx.	400 mm ²
Light wavelength	565 nm

Electrical data¹⁾

Operating voltage	10 V ... 16 V
Ripple, permissible	± 0.7 V
Frequency range	100 Hz ... 700 Hz

Limit data

Operating voltage	
For a period of 1 min	24 V
For a period of 2 h	18 V

¹⁾ The electrical part of the sensor is located on 2 pcb's in the sensor housing.

into the windshield glass, the light beam is totally reflected in the glass 4 times on the outside and 3 times on the inside, after which it enters the sensor again through the second silicone pad.

The width of the light beam, and its penetration angle, provide an adequately homogenous distribution of the reflection points on the outside surface of the windshield, and therefore ensure relatively uniform sensitivity over the whole of the measuring surface.

The second light guide is identical to the first one. The surface at its light exit surface is also slightly curved in the form of a lens. The residual light arriving here is projected onto a photodiode sensor surface by means of an optical aperture. The amount of light received by the diode changes depending upon the degree of windshield wetting. Finally, this photodiode's output signal is conditioned and passed to the microprocessor's A/D converter.

There are two further variables which serve as inputs to the sensor in addition to the optically registered degree of wetting. These are the position of the windshield-wiper lever and the signal from the wiper-motor control cam. The sensor output is used to trigger two relays which switch the 1st and 2nd wiper-motor speeds.

Accessories

Mating connector, 11-pole
AMP-No. 142 704-1

To be ordered from
AMP Deutschland GmbH,
Amperestr. 7-11, D-63225 Langen,
Tel. 0 61 03/70 90.
Details of fastening clips and special adhesive upon request.

Explanation of symbols:

I Beam strength, intensity

Dimension drawings

1 Retaining frame, 2 Cover plate, 3 Retaining element, 4 Leaf spring, 5 Gasket, 6 Plug to fit mating connector AMP, No. 142 704-1, 7 Heating plate, 8 Light guide, 9 Optocoupler, 10 pcb.

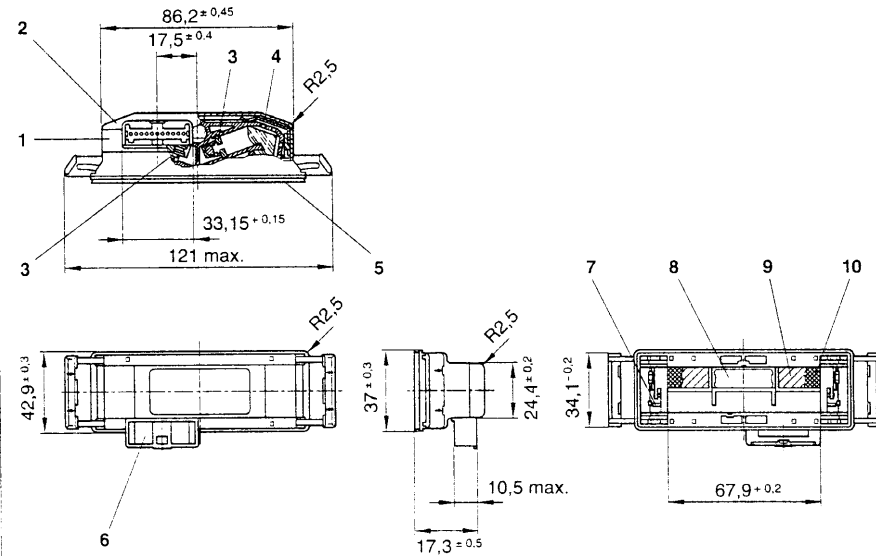

Optical values: The sensor-measuring surface is that strip between the injection point and the decoupling point and approx. 2/3 of the surface of the silicone pads. An LED with a light wavelength in the visible range (green) is used.

Incorporating the rain sensor in the windshield-wiper system

Together with the wiper motor and the steering-column switch, the rain sensor is an integral part of the windshield-wiper installation. Whereby, with the exception of wiping stage 1, the sensor assumes the control of the wiper motor.

The complete wiper system can carry out the following functions:

- Stage 1 wiping (slow wiping),
- Stage 2 wiping (rapid wiping),
- Brief wiping,
- Afterwipe when washer in operation (wipe/wash),
- Automatic control using rain sensor (automatic mode).

Switch position "Stage 1": Via the control stalk and wiper relay 1, the wiper motor is switched to wiping stage 1.

Switch position "Stage 2": Via wiper relay 1 and changeover relay 2, the wiper motor is switched to wiping stage 2. If the wiper is switched back by hand to OFF from wiping stage 2, the wiper motor in wiping stage 1 shifts to the park position.

Switch position "Brief wiping": The windshield-washer pump is operated directly by a pushbutton, and the wiper motor triggered by the relay. Three afterwipe cycles take place after releasing the pushbutton.

Switch position "Automatic mode": The rain sensor is responsible for triggering both the relays for the wiper motor as a function of the degree of wetting of the windshield.

Self-calibration of the sensitivity is performed in this mode. The sensor is able to distinguish between splash water, windshield streaking, and dirt.

Rain sensor (sectional drawing)

1 Windshield, 2 Light guide, 3 Raindrops, 4 Heater, 5 Optical coupling, 6 Optical aperture, 7 Photodiode, 8 Interface, 9 Electronics, 10 LED.

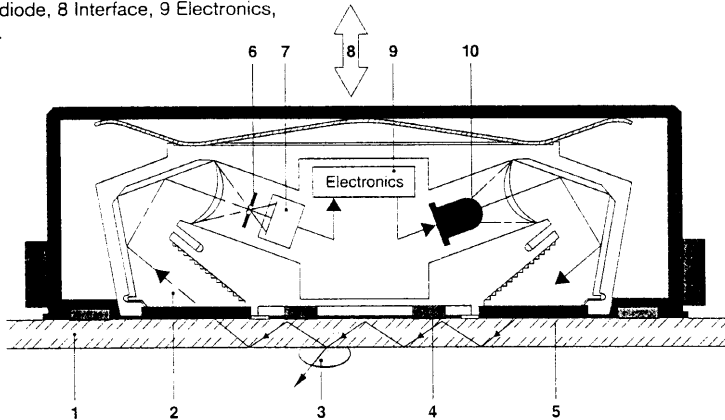

Rain sensor (components)

1 pcb with heater plate, 2 LED mount and plug, 3 Housing interior, 4 Silicone pads, 5 Retaining frame with fastening clips, 6 Leaf spring, 7 Cover plate.

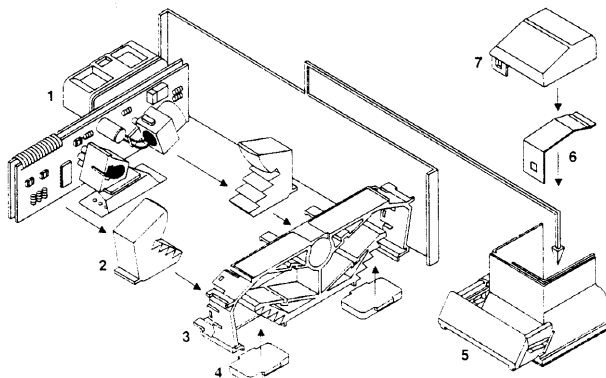

Rain sensors (contd.)

Switch-on conditions

The rain sensor's heater is switched on when the ignition key is turned to "Radio" or "Ignition ON" (Term. 15). At the same time, the control-stalk switch must also be turned to the "Automatic mode" setting in order for the rain sensor to be in the active mode. If the control-stalk switch is already turned to "Automatic" when the ignition switch is turned to "Ignition ON", the control-stalk switch must be shifted to either "Stage 1" or "Neutral" position, and then back again to "Automatic", in order for the rain sensor to switch to the active mode. If the ignition is switched off, or even interrupted briefly, the rain sensor does not switch to the active mode of its own accord.

Initialization of the rain sensor

The first time "Automatic mode" is switched on, the rain sensor switches to the active mode. This immediately triggers a wiping cycle which serves to generate a reference value for the electronic circuitry, which takes into account the prevailing conditions at that moment such as windshield tint, basic-light loss, degree of wetting, dirt, etc.

The optimal setting can shift due to warm-up. After 1 minute, therefore, it is necessary to correct the amplification of the received light signal in the direct mode.

Triggering

In order to trigger a wiping process, the measured signal must be compared with the reference signal. But since the reference value is not a constant, but is dependent upon the particular situation, triggering takes place according to the following two criteria:

1. The difference between the particular measured value of the sensor and the reference value is applied as a triggering threshold. This difference is a measure of the degree of windshield wetting.
2. The rate of rise of the signal and the signal characteristic as a function of time are taken as the measure for raindrop detection.

Automatic mode

Here, four different operating modes are provided:

1. When Automatic mode is switched on, and a dry windshield has been detected, the sensor switches to its basic mode (direct mode, wiping speed 1). Every time rain appears on the windshield, this directly triggers a single wiping cycle, in the course of which a decision is reached as to whether wiping is to continue in Stage 1, or whether no further wiping is to take place after the single wiping cycle. The amount of rain which falls in the subsequent wiping pause is used to determine the interval to the next direct-triggered wiping cycle.

2. As soon as the sensor detects a given amount of rainfall in the wiping pause, it switches over to the interval mode (stage 1 wiping speed). This is the case when an interval is calculated which exceeds the maximum-possible interval (the interval is defined as the period of time in which the wiper remains parked). A wiping cycle is triggered as soon as this period has expired. The wetting is then measured again and a new interval calculated as necessary. Permissible intervals: 0.5 ... 5.0 s.
3. Continuous operation at wiping speed 1.
4. Continuous operation at wiping speed 2.

Changeover conditions

- Depending upon what is happening at the measuring surface, every other mode can be switched to directly from the direct mode.
 - In order to switch to the interval mode, two successive delays until a new wipe event must have expired (within the permissible intervals). The mean value of the delay times serves as the output value for interval operation.
 - Depending upon what is happening at the measuring surface, the switch-over can be made from the interval mode to either of the permanent wiping speeds, provided the calculated amount of rainfall exceeds a given threshold for event value or for event change.
 - In the permanent wiping stages 1 and 2, the amount of rainfall is continuously measured and evaluated in order that the a higher or lower stage can be switched to as necessary. Erratic back-and-forth switching is avoided by a dynamic hysteresis function which depends upon the events of the last 5 wiping cycles.
 - When the direct mode is switched to from either Stage 1 or 2 (when the rain suddenly stops), the system carries out a maximum of 4 (or 3) wiping cycles at the speed in question. The driver must switch through Stage 1 when switching back from Stage 2 to the direct mode.
 - Switching back from the interval mode to the direct mode: If no rain is detected during the wiping pause, the interval is automatically increased in 3 steps until the maximum interval time is exceeded.
Step 1: The old interval time is repeated,
Step 2: The old interval time is increased by 25 %,
Step 3: The new interval time is increased by 50 %.
- If the maximum interval time is not reached following these 3 wiping cycles, and no rain has been registered, the system switches back to the direct mode. If rain is detected in the switch-back period though, the system remains in the interval mode.

Water-splash detection

In the interval mode, sudden, marked changes in the degree of wetting (steep-front signal collapse) can lead to the

triggering of a Stage 2 wiping cycle. The system then returns to the initial status.

Windshield-streaking detection

A streak on the windshield is comprised of a multitude of extremely fine water droplets which dry off more or less quickly. In the direct and interval modes, streaking is detected if the sensor signal indicates that the degree of wetting is decreasing. In this case, in order to prevent unnecessary wiping when there are streaks on the windshield, detection as a function of the signal differential is suppressed, and there remains only the raindrop detection as a function of the signal shape. Differential evaluation becomes active again as soon as the sensor registers wetting or raindrops.

Dirt detection

The rain sensor recognises a dirty windshield, because in contrast to a wet windshield there is no improvement in visibility after the wiper blade has wiped the glass. In this case, the reference value automatically adapts itself to the new situation to prevent the rewipe of the dirty windshield. The reference value adapts again as soon as the windshield is clean.

Safety function

- Glass breakage: If the sensor cannot receive a signal, due for instance to a crack in the vicinity of the sensor area, the system automatically switches to a fixed interval of 4.5 s.
- Electronics failure: In this case, the system guarantees an emergency wiping function in which relay 1 for wiping stage 1 is directly controlled by the control-stalk switch (hardware bypass). This bypass ensures that the protective electronic switch-off remains ineffective in Stage 1 so that the wiper arm cannot self-park.

Blocking protection

In each control-stalk setting, apart from Stage 1, wiper-motor blockage is detected due to the fact that the NPS signal edge is missing. In order to provide protection for the motor, following a delay of 12 secs, relay 1 is clocked as per the following cycle: 2 secs voltage applied, 12 secs pause, 2 secs voltage applied, etc.

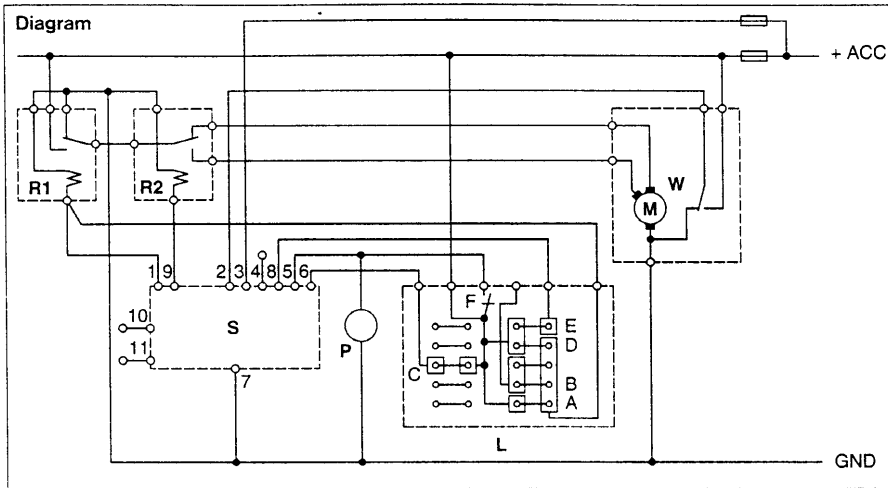

Note

Even without the windshield being wet, a fraction of the light flux is lost naturally on its way from transmitter to receiver. The system compensates for these losses by performing a special calibration upon switch-on. The fact that the silicone pads are "snuggly" fitted to the windshield is of major importance for the sensor's function and reliability, both when the system is installed and also during subsequent in-the-field operation. Changes to the interface surfaces caused by vibration have the same effect as the signal changes caused by raindrops. A selection of appropriate wiper motors with control cam can be found in the "Electric Motor" catalog, and a description of the relays used in the Catalog "Relays, Tractive Magnets" (Part No.: 0 332 209 150).

A Touch-controlled wiping, B OFF, C Rain sensor, D Stage 1, E Stage 2, F Wipe/Wash, P Pump, S Sensor, W Wiper motor, R1 Relay 1, R2 Relay 2.

Connections:

+ ACC Position "Radio"
GND Ground

Connector-pin assignment

- 1 REL1 Switch-on relay
- 2 NPS Wiper-motor control cam
- 3 ACC Position "Radio"
- 4 - Vacant
- 5 WW Steering-column switch
- 6 INT Steering-column switch, interval
- 7 GND Ground
- 8 ST2 Steering-column switch, Stage 2
- 9 REL2 Stage 1/Stage 2 relay
- 10 TX Test
- 11 - Vacant